

DORMER  **PRAMET**

**PERÇAGE
ET ALÉSAGE**

2024



 **DORMER**

 **PRAMET**





















PERÇAGE & ALÉSAGE – CONTENU GÉNÉRAL

PERÇAGE & ALÉSAGE

Outils pour la fabrication de base, la construction, l'entretien, la réparation, la révision. Généralement utilisés avec des outils électriques et des machines conventionnelles. Convient pour des paramètres de coupe faibles.

Outils pour la fabrication mixte. Généralement utilisés avec des machines conventionnelles avec alimentation de la machine et CNC. Convient aux paramètres de coupe modérés.

Outils en carbure monobloc pour des processus productifs et sécurisés. Généralement utilisés avec des machines à commande numérique et pour la fabrication automatisée. Utilisables avec des paramètres de coupe élevés.

	Forets extra courts et à pointer	< 2.5 x D	7
	Forets courts	< 4 x D	17
	Forets longs et extra longs	< 10 x D	35
	Forets pour l'aéronautique	NAS 907	41
	Fraises à chanfreiner et ébavurer		59
	Alésoirs		73
	Coffrets de forets et accessoires		90
	Forets extra courts	< 3 x D	103
	Forets courts	< 5 x D	115
	Forets longs et extra longs	< 25 x D	125
	Forets étagés et forets à lamer		135
	Forets à centrer		147
	Fraises à chanfreiner et ébavurer		157
	Alésoirs		167
	Forets à pointer en carbure		181
	Forets en carbure monobloc	< 8 x D	187
	Forets Hydra (à tête interchangeable)	1.5 – 12 x D	217
	Forets indexables (U-drills)	2 – 5 x D	235
	Alésoirs en carbure		249

INSTRUCTIONS

Comment lire les données du catalogue ? (ISO 13399, icônes, navigation)			258
Aperçu des matériaux, des revêtements et des nuances			270
Forets – informations techniques	274	Tableaux des vitesses d'avance	272
Alésoirs – informations techniques	279	Tableaux des vitesses d'avance	276
Forets indexables – informations techniques	288	Tableaux des vitesses d'avance	281
Groupes de matériaux à usiner (WMG)			291



OUTILS MONOBLOCS – CONTENU (PAR ORDRE ALPHABÉTIQUE)

FAMILLE		FAMILLE		FAMILLE		FAMILLE	
0		A295	95	B660	85	G705	141
2ACO	57	A296	156	B670	86	G706	142
500-6/501-6/502-6	48	A321	18	B680	87	H	
500-12/501-12/502-12	50	A400	143	B690	64	H851	218
A		A402	144	B901	168	H853	219
A002	30	A412	146	B903	82	H855	221
A002S	32	A413	145	B952	83	H858	223
A022	14	A510	120	B953	81	H860	229
A080	99	A520	105	B954	175	H861	229
A087	93	A553	122	C		H8512	224
A088	92	A620	107	CO500-6/CO501-6	55	M	
A089	92	A720	104	CO500-12/CO501-12	56	M900	98
A094	93	A723	8	E		M901	99
A095	94	A777	116	EP	247	M902	99
A099 Drillboy	94	A900	126	E		R	
A100	19	A920	110	G106	67	R003	123
A101	23	A940	128	G107	69	R10A/R15A/R18A	44
A108	33	A952	133	G125	137	R10B/R15B/R18B	46
A110	36	A976	130	G129	62	R10CO/R15CO/R18CO	53
A117	108	A977	131	G132	63	R023	112
A119	10	A978	132	G135	60	R40C/R41C/R42C	42
A120	12	B		G136	66	R88CO/R89CO	52
A122	9	B100	74	G137	164	R122	184
A123	11	B101	174	G138	165	R123	182
A125	38	B121	176	G142	65	R125	185
A130	26	B122	88	G149	159	R200	156
A147	118	B161	173	G154	61	R453	203
A170	24	B170	171	G171	163	R454	199
A188	95	B180	169	G236	71	R457	195
A190	96	B301	80	G314	136	R458	191
A191	97	B400	250	G335	158	R459	207
A191_2	97	B411	254	G338	166	R463	213
A200	148	B441	253	G400	162	R467	210
A201	153	B442	255	G506	68	R510	190
A205	149	B481	251	G560	160	R520	188
A206	150	B610	76	G570	161	R950	225
A210	152	B620	78	G600	70	R960	227
A225	154	B630	84	G702	138	R6011	183
A242	155	B640	177	G703	139	R7131	216
A266	151	B650	79	G704	140		



OUTILS INDEXABLES – CONTENU (PAR ORDRE ALPHABÉTIQUE)

FAMILLE	
0	
802D	236
803D	238
804D	241
805D	243

PLAQUETTES INDEXABLES – CONTENU (PAR ORDRE ALPHABÉTIQUE)

FAMILLE	
S	
SCET	245
XPET	246



**OUTILS POUR LA FABRICATION DE BASE, LA CONSTRUCTION, L'ENTRETIEN,
LA RÉPARATION, LA RÉVISION. GÉNÉRALEMENT UTILISÉS AVEC
DES OUTILS ÉLECTRIQUES ET DES MACHINES CONVENTIONNELLES.**

Code de matériau du corps (BMC)

Groupe standard de base (BSG)

Rapport longueur utile diamètre (ULDR)

Angle d'application

Revêtement

Queue

Forme de spirale

Sens (direction de coupe)

HSS-E	HSS	HSS	HSS	HSS	HSS
	DIN 1897	DIN 1897	DIN 1897	DIN 1897	DIN ANSI
1×D	1×D	1.25×D	1.5×D	2.5×D	2.5×D
180°	90°/120°	120°	120°	135°	135°
λ 20-35°	λ 20-35°	λ 20-35°	λ 20-35°	λ 20-35°	λ 20-35°



Code de famille de produits

Plage de diamètres de coupe PSF

A723	A122	A119	A123	A120	A022
6.00 - 8.00	6.00 - 20.00	3.30 - 5.10	3/32 - 1/4	0.50 - 25.00	0.50 - 16.00

P	P1	■	■	■	■	■													
	P2	■	■	■	■	■	■												
	P3	■	■	■	■	■	■												
	P4	■	■	■	■	■	■												
M	M1		■	■	■	■	■												
	M2		■	■	■	■	■	■											
	M3		■	■	■	■	■	■											
	M4		■	■	■	■	■	■											
K	K1		■				■	■											
	K2		■				■	■											
	K3		■				■	■											
	K4		■				■	■											
	K5		■				■	■											
N	N1		■	■	■	■	■	■											
	N2		■	■	■	■	■	■											
	N3		■	■	■	■	■	■											
	N4		■	■	■	■	■	■											
	N5																		
S	S1		■	■	■	■	■	■											
	S2		■	■	■	■	■	■											
	S3		■	■	■	■	■	■											
	S4		■	■	■	■	■	■											
H	H1																		
	H2																		
	H3																		
	H4																		

A723



Foret pour points de soudure en HSS-E (5% cobalt), finition bronze

Foret doté d'une lèvre et d'une pointe saillante spécialement conçues pour enlever ou «désagréger» les zones soudées par points, généralement utilisé pour enlever les soudures dans un atelier de réparation de véhicules. La goujure courte le rend plus robuste et moins susceptible de se briser lorsqu'il est utilisé dans un appareil portatif. La finition avec traitement bronze est une fine couche d'oxyde et une indication pour le cobalt.

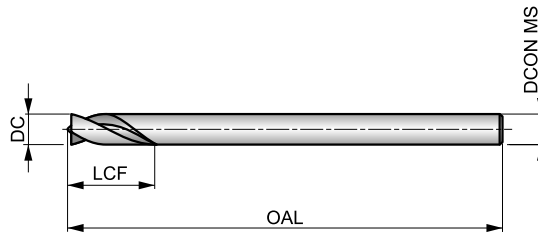

HSS-E	DORMER	1xD
Bronze		λ 20-35°
R	DC h8	

Adéquation du groupe de matériaux de la pièce, valeurs de départ pour la vitesse de coupe (m/min) et code Alpha d'avance. Les tableaux d'avances par tour se trouvent à partir de la page 274.

P1.1 ■ 33 D	P1.2 ■ 37 D	P1.3 ■ 38 D	P2.1 ■ 28 D	P2.2 ■ 25 C	P3.1 ■ 20 C	P3.2 ■ 20 C	P4.1 ■ 20 C
-----------------------	-----------------------	-----------------------	-----------------------	-----------------------	-----------------------	-----------------------	-----------------------

Product	DC	DC	LCF	OAL	DCON MS
	(mm)	(inch)			
A7236.0X66	6.00	0.2362	18.0	66.0	6.00
A7236.0X93	6.00	0.2362	18.0	93.0	6.00
A7238.0X79	8.00	0.3150	24.0	79.0	8.00
A7238.0X117	8.00	0.3150	24.0	117.0	8.00

A122



Foret à pointer en HSS, finition brillante

Foret utilisable pour créer un trou dans le matériau à percer afin de s'assurer que le point de départ est précis. Conçu avec un angle de pointe de 90° ou 120°, ce qui vous donne deux options de pointage. Finition de surface brillante. Convient pour le perçage de nombreux matériaux.

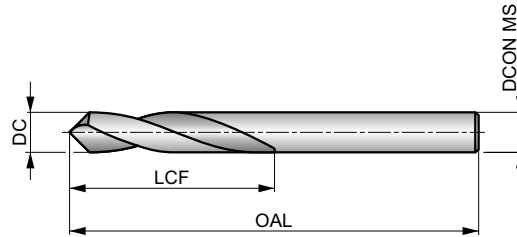

HSS	DIN 1897	1xD
90°/120°	Bright	
λ 20-35°	R	DC h8

Adéquation du groupe de matériaux de la pièce, valeurs de départ pour la vitesse de coupe (m/min) et code Alpha d'avance. Les tableaux d'avances par tour se trouvent à partir de la page 274.

P1.1 ■ 36 E	P1.2 ■ 40 E	P1.3 ■ 41 E	P2.1 ■ 31 E	P2.2 ■ 27 C	P2.3 ■ 24 C	P3.1 ■ 21 C	P3.2 ■ 17 C	P3.3 ■ 14 C	P4.1 ■ 12 C	P4.2 ■ 10 C	P4.3 ■ 9 B	M1.1 ■ 22 C	M1.2 ■ 19 C
M2.1 ■ 20 C	M2.2 ■ 16 C	M3.1 ■ 10 D	M3.2 ■ 9 D	M3.3 ■ 8 D	M4.1 ■ 10 B	K1.1 ■ 32 E	K1.2 ■ 24 C	K1.3 ■ 18 C	K2.1 ■ 25 C	K2.2 ■ 20 C	K2.3 ■ 16 B	K3.1 ■ 22 C	K3.2 ■ 17 C
K3.3 ■ 13 B	K4.1 ■ 20 C	K4.2 ■ 15 C	K4.3 ■ 11 B	K4.4 ■ 10 B	K4.5 ■ 8 B	K5.1 ■ 23 C	K5.2 ■ 17 C	K5.3 ■ 13 B	N1.1 ■ 33 E	N1.2 ■ 25 E	N1.3 ■ 17 E	N2.1 ■ 46 D	N2.2 ■ 42 D
N2.3 ■ 30 D	N3.1 ■ 56 D	N3.2 ■ 33 E	N3.3 ■ 17 D	N4.1 ■ 30 F	N4.2 ■ 35 E	N4.3 ■ 17 D	S1.1 ■ 27 C	S1.2 ■ 12 B	S1.3 ■ 7 A	S2.1 ■ 11 C	S2.2 ■ 6 A	S3.1 ■ 8 C	S3.2 ■ 4 A
S4.1 ■ 6 C	S4.2 ■ 3 A												

Product	DC	DC	LCF	OAL	DCON MS
	(mm)	(inch)			
A1226.0X90	6.00	0.2362	30.0	66.0	6.00
A1226.0X120	6.00	0.2362	30.0	66.0	6.00
A1228.0X90	8.00	0.3150	33.0	79.0	8.00
A1228.0X120	8.00	0.3150	33.0	79.0	8.00
A12210.0X90	10.00	0.3937	35.0	89.0	10.00
A12210.0X120	10.00	0.3937	35.0	89.0	10.00
A12212.0X90	12.00	0.4724	40.0	102.0	12.00
A12212.0X120	12.00	0.4724	40.0	102.0	12.00
A12216.0X90	16.00	0.6299	40.0	115.0	16.00
A12216.0X120	16.00	0.6299	40.0	115.0	16.00
A12220.0X90	20.00	0.7874	55.0	131.0	20.00

A119



Foret court à double pointe en HSS, finition avec traitement vapeur

Foret court à double extrémité conçu pour percer des trous dans la tôle. Possibilité d'utiliser les deux extrémités, ce qui double la durée de vie de l'outil. Pointe conventionnelle à 120° pour faciliter l'auto-centrage. Convient pour percer de nombreux matériaux. La finition avec traitement vapeur retient le fluide de coupe et empêche le collage des copeaux sur l'outil.

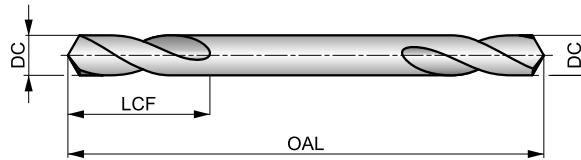

HSS	DIN 1897	1.25xD
120°	ST	
λ 20-35°	R	DC h8

Adéquation du groupe de matériaux de la pièce, valeurs de départ pour la vitesse de coupe (m/min) et code Alpha d'avance. Les tableaux d'avances par tour se trouvent à partir de la page 274.

P1.1 ■ 31 C	P1.2 ■ 34 C	P1.3 ■ 35 C	P2.1 ■ 26 C	P2.2 ■ 23 C	P2.3 ■ 20 C	P3.1 ■ 12 C	P3.2 ■ 9 C	P3.3 ■ 8 C	P4.1 ■ 7 C	P4.2 ■ 6 C	P4.3 ■ 5 A	M1.1 ■ 21 A	M1.2 ■ 17 A
M2.1 ■ 18 A	M2.2 ■ 15 A	M3.1 ■ 8 C	M3.2 ■ 7 C	M3.3 ■ 6 C	M4.1 ■ 10 A	N1.1 ■ 33 C	N1.2 ■ 25 C	N1.3 ■ 17 C	N2.1 ■ 46 C	N2.2 ■ 42 C	N2.3 ■ 30 C	N3.1 ■ 56 C	N3.2 ■ 33 C
N3.3 ■ 17 A	N4.1 ■ 30 I	N4.2 ■ 35 C	S1.1 ■ 27 A	S1.2 ■ 12 A	S1.3 ■ 17 A	S2.1 ■ 5 C	S2.2 ■ 4 C	S3.1 ■ 4 C	S3.2 ■ 3 C	S4.1 ■ 3 C	S4.2 ■ 2 C		

Foret pour perçage de tôles.

Product	DC	DC	LCF	OAL	DCON MS
	(mm)	(inch)			
A1193.3	3.30	0.1299	11.0	49.0	3.30
A1193.6	3.60	0.1417	12.0	52.0	3.60
A1194.1	4.10	0.1614	14.0	55.0	4.10
A1194.2	4.20	0.1654	14.0	55.0	4.20
A1194.9	4.90	0.1929	17.0	62.0	4.90
A1195.1	5.10	0.2008	17.0	62.0	5.10

A123



Foret extra-court en HSS, finition avec traitement vapeur, pour tôle

Foret spécialement conçu pour le perçage des matériaux fins et de la tôle. Sa pointe à 120° et sa finition avec traitement vapeur empêche le matériau de la pièce de coller aux arêtes de coupe, ce qui donne une meilleure finition du trou et un diamètre plus précis. Convient pour le perçage dans de nombreux matériaux.

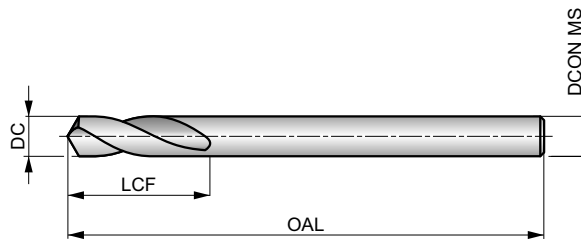

HSS	DIN 1897	1.5xD
120°	ST	
λ 20-35°	R	DC h8

Adéquation du groupe de matériaux de la pièce, valeurs de départ pour la vitesse de coupe (m/min) et code Alpha d'avance. Les tableaux d'avances par tour se trouvent à partir de la page 274.

P1.1 ■ 36 E	P1.2 ■ 40 E	P1.3 ■ 41 E	P2.1 ■ 31 E	P2.2 ■ 27 C	P2.3 ■ 24 C	P3.1 ■ 21 C	P3.2 ■ 17 C	P3.3 ■ 14 C	P4.1 ■ 12 C	P4.2 ■ 10 C	P4.3 ■ 9 B	M1.1 ■ 22 C	M1.2 ■ 19 C
M2.1 ■ 20 C	M2.2 ■ 16 C	M3.1 ■ 10 D	M3.2 ■ 9 D	M3.3 ■ 8 D	M4.1 ■ 10 B	N1.1 ■ 33 E	N1.2 ■ 25 E	N1.3 ■ 17 E	N2.1 ■ 46 D	N2.2 ■ 42 D	N2.3 ■ 30 D	N3.1 ■ 56 D	N3.2 ■ 33 E
N3.3 ■ 17 D	N4.1 ■ 30 F	N4.2 ■ 35 E	N4.3 ■ 17 D	S1.1 ■ 27 C	S1.2 ■ 12 B	S1.3 ■ 7 A	S2.1 ■ 11 C	S2.2 ■ 6 A	S3.1 ■ 8 C	S3.2 ■ 4 A	S4.1 ■ 6 C	S4.2 ■ 3 A	

Foret pour perçage de tôles.

Product	DC	DC	DC	LCF	OAL	DCON MS
	(inch)	(mm)	(inch)			
A1233/325	3/32	2.38	0.0937	14.0	43.0	2.38
A1232.55	–	2.50	0.0984	14.0	43.0	2.50
A1233.05	–	3.00	0.1181	16.0	46.0	3.00
A1231/85	1/8	3.18	0.1250	18.0	49.0	3.18
A1233.25	–	3.20	0.1260	18.0	49.0	3.20
A1233.35	–	3.30	0.1299	18.0	49.0	3.30
A1233.55	–	3.50	0.1378	18.0	52.0	3.50
A1233.75	–	3.70	0.1457	18.0	52.0	3.70
A1235/325	5/32	3.97	0.1563	18.0	55.0	3.97
A1234.05	–	4.00	0.1575	18.0	55.0	4.00
A1234.15	–	4.10	0.1614	18.0	55.0	4.10
A1234.25	–	4.20	0.1654	18.0	55.0	4.20
A1234.55	–	4.50	0.1772	18.0	58.0	4.50
A1233/165	3/16	4.76	0.1875	18.0	62.0	4.76
A1234.85	–	4.80	0.1890	18.0	62.0	4.80
A1234.95	–	4.90	0.1929	18.0	62.0	4.90
A1235.05	–	5.00	0.1969	18.0	62.0	5.00
A1235.55	–	5.50	0.2165	18.0	66.0	5.50
A1237/325	7/32	5.56	0.2188	18.0	66.0	5.56
A1236.05	–	6.00	0.2362	18.0	66.0	6.00
A1231/45	1/4	6.35	0.2500	19.0	70.0	6.35

A120



Foret extra-court en HSS, finition avec traitement vapeur

Foret polyvalent avec finition traitement vapeur. Sa pointe à 135° avec affûtage en croix réduit les forces lors du perçage et empêche le foret de dérapier sur la surface du matériau. La finition avec traitement vapeur retient le liquide de coupe et empêche le collage des copeaux sur l'outil. Convient pour le perçage manuel et mécanique de nombreux matériaux.

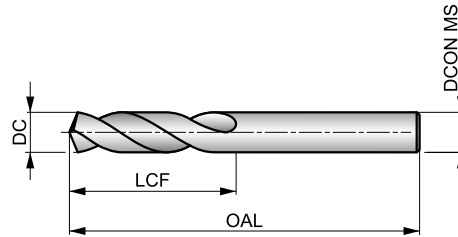

HSS	DIN 1897	2.5xD
135°	ST	
λ 20-35°	R	DC h8

Adéquation du groupe de matériaux de la pièce, valeurs de départ pour la vitesse de coupe (m/min) et code Alpha d'avance. Les tableaux d'avances par tour se trouvent à partir de la page 274.

P1.1 ■ 36 J	P1.2 ■ 40 J	P1.3 ■ 41 J	P2.1 ■ 31 J	P2.2 ■ 27 G	P2.3 ■ 24 F	P3.1 ■ 21 G	P3.2 ■ 17 G	P3.3 ■ 14 F	P4.1 ■ 12 G	P4.2 ■ 10 F	P4.3 ■ 9 E	M1.1 ■ 22 F	M1.2 ■ 19 F
M2.1 ■ 20 F	M2.2 ■ 16 F	M3.1 ■ 10 H	M3.2 ■ 9 H	M3.3 ■ 8 H	M4.1 ■ 10 D	K1.1 ■ 32 J	K1.2 ■ 24 G	K1.3 ■ 18 G	K2.1 ■ 25 F	K2.2 ■ 20 F	K2.3 ■ 16 F	K3.1 ■ 22 F	K3.2 ■ 17 F
K3.3 ■ 13 F	K4.1 ■ 20 F	K4.2 ■ 15 F	K4.3 ■ 11 F	K4.4 ■ 10 F	K4.5 ■ 8 F	K5.1 ■ 23 F	K5.2 ■ 17 F	K5.3 ■ 13 F	N1.1 ■ 33 K	N1.2 ■ 25 K	N1.3 ■ 17 J	N2.1 ■ 46 I	N2.2 ■ 42 I
N2.3 ■ 30 I	N3.1 ■ 64 I	N3.2 ■ 38 J	N3.3 ■ 19 H	N4.1 ■ 30 K	N4.2 ■ 35 I	N4.3 ■ 17 G	S1.1 ■ 27 G	S1.2 ■ 16 E	S1.3 ■ 8 C	S2.1 ■ 11 F	S2.2 ■ 6 B	S3.1 ■ 8 F	S3.2 ■ 4 B
S4.1 ■ 6 F	S4.2 ■ 3 B												

DC <= 1mm Brillant; avec pointe 118° pour DC <= 2.9mm et >= 13.0mm.

Product	DC (inch)	DC (mm)	DC (inch)	LCF (mm)	OAL (mm)	DCON MS (mm)
A120.5	–	0.50	0.0197	3.0	20.0	0.50
A120.6	–	0.60	0.0236	3.5	21.0	0.60
A120.7	–	0.70	0.0276	4.5	23.0	0.70
A1201/32	1/32	0.79	0.0313	5.0	24.0	0.79
A120.8	–	0.80	0.0315	5.0	24.0	0.80
A120.9	–	0.90	0.0354	5.5	25.0	0.90
A1201.0	–	1.00	0.0394	6.0	26.0	1.00
A1201.1	–	1.10	0.0433	7.0	28.0	1.10
A1201.2	–	1.20	0.0472	8.0	30.0	1.20
A1201.3	–	1.30	0.0512	8.0	30.0	1.30
A1201.4	–	1.40	0.0551	9.0	32.0	1.40
A1201.5	–	1.50	0.0591	9.0	32.0	1.50
A1201/16	1/16	1.59	0.0625	10.0	34.0	1.59
A1201.6	–	1.60	0.0630	10.0	34.0	1.60
A1201.7	–	1.70	0.0669	10.0	34.0	1.70
A1201.8	–	1.80	0.0709	11.0	36.0	1.80
A1201.9	–	1.90	0.0748	11.0	36.0	1.90
A1205/64	5/64	1.98	0.0781	12.0	38.0	1.98
A1202.0	–	2.00	0.0787	12.0	38.0	2.00
A1202.1	–	2.10	0.0827	12.0	38.0	2.10
A1202.2	–	2.20	0.0866	13.0	40.0	2.20
A1202.25	–	2.25	0.0886	13.0	40.0	2.25
A1202.3	–	2.30	0.0906	13.0	40.0	2.30

Product	DC (inch)	DC (mm)	DC (inch)	LCF (mm)	OAL (mm)	DCON MS (mm)
A1203/32	3/32	2.38	0.0938	14.0	43.0	2.38
A1202.4	–	2.40	0.0945	14.0	43.0	2.40
A1202.5	–	2.50	0.0984	14.0	43.0	2.50
A1202.6	–	2.60	0.1024	14.0	43.0	2.60
A1202.7	–	2.70	0.1063	16.0	46.0	2.70
A1207/64	7/64	2.78	0.1094	16.0	46.0	2.78
A1202.8	–	2.80	0.1102	16.0	46.0	2.80
A1202.9	–	2.90	0.1142	16.0	46.0	2.90
A1203.0	–	3.00	0.1181	16.0	46.0	3.00
A1203.1	–	3.10	0.1220	18.0	49.0	3.10
A1201/8	1/8	3.18	0.1250	18.0	49.0	3.18
A1203.2	–	3.20	0.1260	18.0	49.0	3.20
A1203.25	–	3.25	0.1280	18.0	49.0	3.25
A1203.3	–	3.30	0.1299	18.0	49.0	3.30
A1203.4	–	3.40	0.1339	20.0	52.0	3.40
A1203.5	–	3.50	0.1378	20.0	52.0	3.50
A1209/64	9/64	3.57	0.1406	20.0	52.0	3.57
A1203.6	–	3.60	0.1417	20.0	52.0	3.60
A1203.7	–	3.70	0.1457	20.0	52.0	3.70
A1203.8	–	3.80	0.1496	22.0	55.0	3.80
A1203.9	–	3.90	0.1535	22.0	55.0	3.90
A1205/32	5/32	3.97	0.1563	22.0	55.0	3.97
A1204.0	–	4.00	0.1575	22.0	55.0	4.00



Product	DC	DC	DC	LCF	OAL	D CON MS
	(inch)	(mm)	(inch)	(mm)	(mm)	(mm)
A1204.1	–	4.10	0.1614	22.0	55.0	4.10
A1204.2	–	4.20	0.1654	22.0	55.0	4.20
A1204.3	–	4.30	0.1693	24.0	58.0	4.30
A12011/64	11/64	4.37	0.1719	24.0	58.0	4.37
A1204.4	–	4.40	0.1732	24.0	58.0	4.40
A1204.5	–	4.50	0.1772	24.0	58.0	4.50
A1204.6	–	4.60	0.1811	24.0	58.0	4.60
A1204.7	–	4.70	0.1850	24.0	58.0	4.70
A1203/16	3/16	4.76	0.1875	26.0	62.0	4.76
A1204.8	–	4.80	0.1890	26.0	62.0	4.80
A1204.9	–	4.90	0.1929	26.0	62.0	4.90
A1205.0	–	5.00	0.1969	26.0	62.0	5.00
A1205.1	–	5.10	0.2008	26.0	62.0	5.10
A12013/64	13/64	5.16	0.2031	26.0	62.0	5.16
A1205.2	–	5.20	0.2047	26.0	62.0	5.20
A1205.3	–	5.30	0.2087	26.0	62.0	5.30
A1205.4	–	5.40	0.2126	28.0	66.0	5.40
A1205.5	–	5.50	0.2165	28.0	66.0	5.50
A1207/32	7/32	5.56	0.2188	28.0	66.0	5.56
A1205.6	–	5.60	0.2205	28.0	66.0	5.60
A1205.7	–	5.70	0.2244	28.0	66.0	5.70
A1205.8	–	5.80	0.2283	28.0	66.0	5.80
A1205.9	–	5.90	0.2323	28.0	66.0	5.90
A12015/64	15/64	5.95	0.2344	28.0	66.0	5.95
A1206.0	–	6.00	0.2362	28.0	66.0	6.00
A1206.1	–	6.10	0.2402	31.0	70.0	6.10
A1206.2	–	6.20	0.2441	31.0	70.0	6.20
A1206.3	–	6.30	0.2480	31.0	70.0	6.30
A1201/4	1/4	6.35	0.2500	31.0	70.0	6.35
A1206.4	–	6.40	0.2520	31.0	70.0	6.40
A1206.5	–	6.50	0.2559	31.0	70.0	6.50
A1206.6	–	6.60	0.2598	31.0	70.0	6.60
A1206.7	–	6.70	0.2638	31.0	70.0	6.70
A1206.8	–	6.80	0.2677	34.0	74.0	6.80
A1206.9	–	6.90	0.2717	34.0	74.0	6.90
A1207.0	–	7.00	0.2756	34.0	74.0	7.00
A1207.1	–	7.10	0.2795	34.0	74.0	7.10
A1209/32	9/32	7.14	0.2813	34.0	74.0	7.14
A1207.2	–	7.20	0.2835	34.0	74.0	7.20
A1207.3	–	7.30	0.2874	34.0	74.0	7.30
A1207.4	–	7.40	0.2913	34.0	74.0	7.40
A1207.5	–	7.50	0.2953	34.0	74.0	7.50
A1207.6	–	7.60	0.2992	37.0	79.0	7.60
A1207.7	–	7.70	0.3031	37.0	79.0	7.70
A1207.8	–	7.80	0.3071	37.0	79.0	7.80
A1207.9	–	7.90	0.3110	37.0	79.0	7.90
A1205/16	5/16	7.94	0.3125	37.0	79.0	7.94
A1208.0	–	8.00	0.3150	37.0	79.0	8.00
A1208.1	–	8.10	0.3189	37.0	79.0	8.10
A1208.2	–	8.20	0.3228	37.0	79.0	8.20
A1208.3	–	8.30	0.3268	37.0	79.0	8.30
A1208.4	–	8.40	0.3307	37.0	79.0	8.40
A1208.5	–	8.50	0.3346	37.0	79.0	8.50
A1208.6	–	8.60	0.3386	40.0	84.0	8.60

Product	DC	DC	DC	LCF	OAL	D CON MS
	(inch)	(mm)	(inch)	(mm)	(mm)	(mm)
A1208.7	–	8.70	0.3425	40.0	84.0	8.70
A12011/32	11/32	8.73	0.3438	40.0	84.0	8.73
A1208.8	–	8.80	0.3465	40.0	84.0	8.80
A1208.9	–	8.90	0.3504	40.0	84.0	8.90
A1209.0	–	9.00	0.3543	40.0	84.0	9.00
A1209.1	–	9.10	0.3583	40.0	84.0	9.10
A1209.2	–	9.20	0.3622	40.0	84.0	9.20
A1209.3	–	9.30	0.3661	40.0	84.0	9.30
A1209.4	–	9.40	0.3701	40.0	84.0	9.40
A1209.5	–	9.50	0.3740	40.0	84.0	9.50
A1203/8	3/8	9.52	0.3750	43.0	89.0	9.52
A1209.6	–	9.60	0.3780	43.0	89.0	9.60
A1209.7	–	9.70	0.3819	43.0	89.0	9.70
A1209.8	–	9.80	0.3858	43.0	89.0	9.80
A1209.9	–	9.90	0.3898	43.0	89.0	9.90
A12010.0	–	10.00	0.3937	43.0	89.0	10.00
A12010.1	–	10.10	0.3976	43.0	89.0	10.10
A12010.2	–	10.20	0.4016	43.0	89.0	10.20
A12010.3	–	10.30	0.4055	43.0	89.0	10.30
A12010.5	–	10.50	0.4134	43.0	89.0	10.50
A12010.8	–	10.80	0.4252	47.0	95.0	10.80
A12011.0	–	11.00	0.4331	47.0	95.0	11.00
A1207/16	7/16	11.11	0.4375	47.0	95.0	11.11
A12011.3	–	11.30	0.4449	47.0	95.0	11.30
A12011.5	–	11.50	0.4528	47.0	95.0	11.50
A12011.7	–	11.70	0.4606	47.0	95.0	11.70
A12011.8	–	11.80	0.4646	47.0	95.0	11.80
A12012.0	–	12.00	0.4724	51.0	102.0	12.00
A12012.1	–	12.10	0.4764	51.0	102.0	12.10
A12012.2	–	12.20	0.4803	51.0	102.0	12.20
A12012.5	–	12.50	0.4921	51.0	102.0	12.50
A1201/2	1/2	12.70	0.5000	51.0	102.0	12.70
A12013.0	–	13.00	0.5118	51.0	102.0	13.00
A12013.5	–	13.50	0.5315	54.0	107.0	13.50
A12014.0	–	14.00	0.5512	54.0	107.0	14.00
A1209/16	9/16	14.29	0.5625	56.0	111.0	14.29
A12014.5	–	14.50	0.5709	56.0	111.0	14.50
A12015.0	–	15.00	0.5906	56.0	111.0	15.00
A12015.5	–	15.50	0.6102	58.0	115.0	15.50
A1205/8	5/8	15.88	0.6250	58.0	115.0	15.88
A12016.0	–	16.00	0.6299	58.0	115.0	16.00
A12016.5	–	16.50	0.6496	60.0	119.0	16.50
A12017.0	–	17.00	0.6693	60.0	119.0	17.00
A12011/16	11/16	17.46	0.6875	62.0	123.0	17.46
A12017.5	–	17.50	0.6890	62.0	123.0	17.50
A12018.0	–	18.00	0.7087	62.0	123.0	18.00
A12018.5	–	18.50	0.7283	64.0	127.0	18.50
A12019.0	–	19.00	0.7480	64.0	127.0	19.00
A12020.0	–	20.00	0.7874	66.0	131.0	20.00
A12020.5	–	20.50	0.8071	68.0	136.0	20.50
A12013/16	13/16	20.64	0.8125	68.0	136.0	20.64
A12021.0	–	21.00	0.8268	68.0	136.0	21.00
A12022.0	–	22.00	0.8661	70.0	141.0	22.00
A12025.0	–	25.00	0.9843	75.0	151.0	25.00

A022



Foret extra-court en HSS, revêtement TiN en pointe

Foret polyvalent doté d'une pointe spéciale à 135° avec affûtage en croix conçue pour faciliter l'auto-centrage lors du perçage à la main et sur machines, ce qui permet d'obtenir un trou plus précis et une meilleure qualité de finition. Convient pour le perçage de nombreux matériaux. Le revêtement TiN en pointe améliore les performances et prolonge la durée de vie de l'outil.

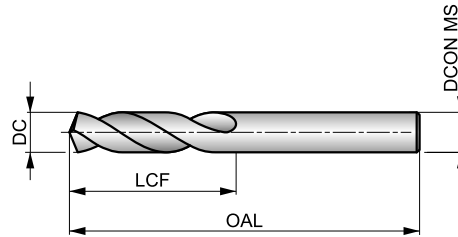

HSS	DIN ANSI	2.5xD
135°	TiN-Tip	
λ 20-35°	R	DC h8

Adéquation du groupe de matériaux de la pièce, valeurs de départ pour la vitesse de coupe (m/min) et code Alpha d'avance. Les tableaux d'avances par tour se trouvent à partir de la page 274.

P1.1 ■ 33 K	P1.2 ■ 37 K	P1.3 ■ 38 K	P2.1 ■ 28 K	P2.2 ■ 25 I	P2.3 ■ 22 G	P3.1 ■ 24 H	P3.2 ■ 19 H	P3.3 ■ 16 G	P4.1 ■ 14 H	P4.2 ■ 12 G	P4.3 ▣ 10 E	M1.1 ■ 21 G	M1.2 ■ 17 G
M2.1 ■ 18 G	M2.2 ■ 15 G	M3.1 ▣ 9 I	M3.2 ▣ 8 I	M3.3 ▣ 7 I	M4.1 ▣ 9 E	K1.1 ■ 32 K	K1.2 ■ 24 I	K1.3 ■ 18 I	K2.1 ■ 25 G	K2.2 ■ 20 G	K2.3 ▣ 16 G	K3.1 ■ 22 G	K3.2 ■ 17 G
K3.3 ▣ 13 G	K4.1 ■ 20 G	K4.2 ■ 15 G	K4.3 ▣ 11 G	K4.4 ▣ 10 G	K4.5 ▣ 8 G	K5.1 ■ 23 G	K5.2 ■ 17 G	K5.3 ▣ 13 G	N1.1 ■ 40 F	N1.2 ■ 30 F	N1.3 ■ 20 K	N2.1 ■ 49 J	N2.2 ■ 44 J
N2.3 ■ 32 J	N3.1 ▣ 64 I	N3.2 ▣ 38 K	N3.3 ▣ 19 H	N4.1 ▣ 30 K	N4.2 ▣ 35 I	N4.3 ▣ 17 G	S1.1 ■ 25 I	S1.2 ▣ 14 F	S1.3 ▣ 8 C	S2.1 ▣ 11 F	S2.2 ▣ 6 B	S3.1 ▣ 8 F	S3.2 ▣ 4 B
S4.1 ▣ 6 F	S4.2 ▣ 3 B												

DC < 2mm Brillant; DC >= 2mm revêtu TiN en pointe avec affûtage en croix.
Les produits de cette série sont également disponibles en coffret. Voir A088.

Product	DC (inch)	DC (mm)	DC (inch)	LCF (mm)	OAL (mm)	DCON MS (mm)
A022.5	-	0.50	0.0197	3.0	20.0	0.50
A022.6	-	0.60	0.0236	3.5	21.0	0.60
A022.7	-	0.70	0.0276	4.5	23.0	0.70
A0221/32	1/32	0.79	0.0313	13.0	35.0	0.79
A022.8	-	0.80	0.0315	5.0	24.0	0.80
A022.9	-	0.90	0.0354	5.5	25.0	0.90
A0221.0	-	1.00	0.0394	6.0	26.0	1.00
A0221.1	-	1.10	0.0433	7.0	28.0	1.10
A0223/64	3/64	1.19	0.0469	13.0	35.0	1.19
A0221.2	-	1.20	0.0472	8.0	30.0	1.20
A0221.3	-	1.30	0.0512	8.0	30.0	1.30
A0221.4	-	1.40	0.0551	9.0	32.0	1.40
A0221.5	-	1.50	0.0591	9.0	32.0	1.50
A0221/16	1/16	1.59	0.0625	16.0	41.0	1.59
A0221.6	-	1.60	0.0630	10.0	34.0	1.60
A0221.7	-	1.70	0.0669	10.0	34.0	1.70
A0221.8	-	1.80	0.0709	11.0	36.0	1.80
A0221.9	-	1.90	0.0748	11.0	36.0	1.90
A0225/64	5/64	1.98	0.0781	17.0	43.0	1.98
A0222.0	-	2.00	0.0787	12.0	38.0	2.00
A0222.1	-	2.10	0.0827	12.0	38.0	2.10
A0222.2	-	2.20	0.0866	13.0	40.0	2.20

Product	DC (inch)	DC (mm)	DC (inch)	LCF (mm)	OAL (mm)	DCON MS (mm)
A0222.25	-	2.25	0.0886	13.0	40.0	2.25
A0222.3	-	2.30	0.0906	13.0	40.0	2.30
A0223/32	3/32	2.38	0.0938	20.0	45.0	2.38
A0222.4	-	2.40	0.0945	14.0	43.0	2.40
A0222.5	-	2.50	0.0984	14.0	43.0	2.50
A0222.6	-	2.60	0.1024	14.0	43.0	2.60
A0222.65	-	2.65	0.1043	14.0	43.0	2.65
A0222.7	-	2.70	0.1063	16.0	46.0	2.70
A0227/64	7/64	2.78	0.1094	22.0	47.0	2.78
A0222.8	-	2.80	0.1102	16.0	46.0	2.80
A0222.9	-	2.90	0.1142	16.0	46.0	2.90
A0223.0	-	3.00	0.1181	16.0	46.0	3.00
A0223.1	-	3.10	0.1220	18.0	49.0	3.10
A0221/8	1/8	3.18	0.1250	23.0	49.0	3.18
A0223.2	-	3.20	0.1260	18.0	49.0	3.20
A0223.25	-	3.25	0.1280	18.0	49.0	3.25
A0223.3	-	3.30	0.1299	18.0	49.0	3.30
A0223.4	-	3.40	0.1339	20.0	52.0	3.40
A0223.5	-	3.50	0.1378	20.0	52.0	3.50
A0229/64	9/64	3.57	0.1406	25.0	50.0	3.57
A0223.6	-	3.60	0.1417	20.0	52.0	3.60
A0223.7	-	3.70	0.1457	20.0	52.0	3.70

Product	DC	DC	DC	LCF	OAL	DCON MS
	(inch)	(mm)	(inch)	(mm)	(mm)	(mm)
A0223.8	–	3.80	0.1496	22.0	55.0	3.80
A0223.9	–	3.90	0.1535	22.0	55.0	3.90
A0225/32	5/32	3.97	0.1563	26.0	53.0	3.97
A0224.0	–	4.00	0.1575	22.0	55.0	4.00
A0224.1	–	4.10	0.1614	22.0	55.0	4.10
A0224.2	–	4.20	0.1654	22.0	55.0	4.20
A0224.3	–	4.30	0.1693	24.0	58.0	4.30
A02211/64	11/64	4.37	0.1719	28.0	55.0	4.37
A0224.4	–	4.40	0.1732	24.0	58.0	4.40
A0224.5	–	4.50	0.1772	24.0	58.0	4.50
A0224.6	–	4.60	0.1811	24.0	58.0	4.60
A0224.7	–	4.70	0.1850	24.0	58.0	4.70
A0223/16	3/16	4.76	0.1875	30.0	57.0	4.76
A0224.8	–	4.80	0.1890	26.0	62.0	4.80
A0224.9	–	4.90	0.1929	26.0	62.0	4.90
A0225.0	–	5.00	0.1969	26.0	62.0	5.00
A0225.1	–	5.10	0.2008	26.0	62.0	5.10
A02213/64	13/64	5.16	0.2031	31.0	58.0	5.16
A0225.2	–	5.20	0.2047	26.0	62.0	5.20
A0225.3	–	5.30	0.2087	26.0	62.0	5.30
A0225.4	–	5.40	0.2126	28.0	66.0	5.40
A0225.5	–	5.50	0.2165	28.0	66.0	5.50
A0227/32	7/32	5.56	0.2188	33.0	61.0	5.56
A0225.6	–	5.60	0.2205	28.0	66.0	5.60
A0225.7	–	5.70	0.2244	28.0	66.0	5.70
A0225.8	–	5.80	0.2283	28.0	66.0	5.80
A0225.9	–	5.90	0.2323	28.0	66.0	5.90
A02215/64	15/64	5.95	0.2344	34.0	63.0	5.95
A0226.0	–	6.00	0.2362	28.0	66.0	6.00
A0226.1	–	6.10	0.2402	31.0	70.0	6.10
A0226.2	–	6.20	0.2441	31.0	70.0	6.20
A0226.3	–	6.30	0.2480	31.0	70.0	6.30
A0221/4	1/4	6.35	0.2500	36.0	65.0	6.35
A0226.4	–	6.40	0.2520	31.0	70.0	6.40
A0226.5	–	6.50	0.2559	31.0	70.0	6.50
A0226.6	–	6.60	0.2598	31.0	70.0	6.60
A0226.7	–	6.70	0.2638	31.0	70.0	6.70
A0226.8	–	6.80	0.2677	34.0	74.0	6.80
A0226.9	–	6.90	0.2717	34.0	74.0	6.90
A0227.0	–	7.00	0.2756	34.0	74.0	7.00
A0227.1	–	7.10	0.2795	34.0	74.0	7.10
A0229/32	9/32	7.14	0.2813	40.0	70.0	7.14
A0227.2	–	7.20	0.2835	34.0	74.0	7.20
A0227.3	–	7.30	0.2874	34.0	74.0	7.30
A0227.4	–	7.40	0.2913	34.0	74.0	7.40
A0227.5	–	7.50	0.2953	34.0	74.0	7.50
A0227.6	–	7.60	0.2992	37.0	79.0	7.60
A0227.7	–	7.70	0.3031	37.0	79.0	7.70
A0227.8	–	7.80	0.3071	37.0	79.0	7.80
A0227.9	–	7.90	0.3110	37.0	79.0	7.90
A0225/16	5/16	7.94	0.3125	43.0	73.0	7.94
A0228.0	–	8.00	0.3150	37.0	79.0	8.00
A0228.1	–	8.10	0.3189	37.0	79.0	8.10

Product	DC	DC	DC	LCF	OAL	DCON MS
	(inch)	(mm)	(inch)	(mm)	(mm)	(mm)
A0228.2	–	8.20	0.3228	37.0	79.0	8.20
A0228.3	–	8.30	0.3268	37.0	79.0	8.30
A0228.4	–	8.40	0.3307	37.0	79.0	8.40
A0228.5	–	8.50	0.3346	37.0	79.0	8.50
A0228.6	–	8.60	0.3386	40.0	84.0	8.60
A0228.7	–	8.70	0.3425	40.0	84.0	8.70
A02211/32	11/32	8.73	0.3438	45.0	78.0	8.73
A0228.8	–	8.80	0.3465	40.0	84.0	8.80
A0228.9	–	8.90	0.3504	40.0	84.0	8.90
A0229.0	–	9.00	0.3543	40.0	84.0	9.00
A0229.1	–	9.10	0.3583	40.0	84.0	9.10
A0229.2	–	9.20	0.3622	40.0	84.0	9.20
A0229.3	–	9.30	0.3661	40.0	84.0	9.30
A0229.4	–	9.40	0.3701	40.0	84.0	9.40
A0229.5	–	9.50	0.3740	40.0	84.0	9.50
A0223/8	3/8	9.52	0.3750	48.0	81.0	9.52
A0229.6	–	9.60	0.3780	43.0	89.0	9.60
A0229.7	–	9.70	0.3819	43.0	89.0	9.70
A0229.8	–	9.80	0.3858	43.0	89.0	9.80
A0229.9	–	9.90	0.3898	43.0	89.0	9.90
A02210.0	–	10.00	0.3937	43.0	89.0	10.00
A02210.1	–	10.10	0.3976	43.0	89.0	10.10
A02210.2	–	10.20	0.4016	43.0	89.0	10.20
A02210.3	–	10.30	0.4055	43.0	89.0	10.30
A02213/32	13/32	10.32	0.4063	51.0	86.0	10.32
A02210.4	–	10.40	0.4094	43.0	89.0	10.40
A02210.5	–	10.50	0.4134	43.0	89.0	10.50
A02210.6	–	10.60	0.4173	43.0	89.0	10.60
A02210.8	–	10.80	0.4252	47.0	95.0	10.80
A02211.0	–	11.00	0.4331	47.0	95.0	11.00
A02211.1	–	11.10	0.4370	47.0	95.0	11.10
A0227/16	7/16	11.11	0.4375	54.0	89.0	11.11
A02211.2	–	11.20	0.4409	47.0	95.0	11.20
A02211.3	–	11.30	0.4449	47.0	95.0	11.30
A02211.5	–	11.50	0.4528	47.0	95.0	11.50
A02211.7	–	11.70	0.4606	47.0	95.0	11.70
A02211.8	–	11.80	0.4646	47.0	95.0	11.80
A02211.9	–	11.90	0.4685	51.0	102.0	11.90
A02212.0	–	12.00	0.4724	51.0	102.0	12.00
A02212.1	–	12.10	0.4764	51.0	102.0	12.10
A02212.2	–	12.20	0.4803	51.0	102.0	12.20
A02212.5	–	12.50	0.4921	51.0	102.0	12.50
A0221/2	1/2	12.70	0.5000	60.0	98.0	12.70
A02213.0	–	13.00	0.5118	51.0	102.0	13.00
A02213.5	–	13.50	0.5315	54.0	107.0	13.50
A02214.0	–	14.00	0.5512	54.0	107.0	14.00
A0229/16	9/16	14.29	0.5625	67.0	105.0	14.29
A02214.5	–	14.50	0.5709	56.0	111.0	14.50
A02215.0	–	15.00	0.5906	56.0	111.0	15.00
A02215.5	–	15.50	0.6102	58.0	115.0	15.50
A0225/8	5/8	15.88	0.6250	73.0	111.0	15.88
A02216.0	–	16.00	0.6299	58.0	115.0	16.00

Code de matériau du corps (BMC)	HSS	HSS	HSS	HSS	HSS	HSS	HSS	HSS									
Groupe standard de base (BSG)		DIN 338	DIN 338		DIN 345	DIN 338	DIN 338	DIN 338									
Rapport longueur utile diamètre (ULDR)	3.5xD	4xD	4xD	4xD	4xD	4xD	4xD	4xD									
Angle d'application																	
Revêtement																	
Queue																	
Forme de spirale																	
Sens (direction de coupe)																	

NEW

Code de famille de produits		A321	A100	A101	A170	A130	A002	A002S	A108								
Plage de diamètres de coupe PSF		3.0 - 13.0	0.20 - 20.00	1.00 - 12.00	13.00 - 1.1/4	3.00 - 2"	1.00 - 16.00	2.00 - 13.00	1.00 - 16.00								
P	P1	■	■	■	■	■	■	■	■								
	P2	■	■	■	■	■	■	■	■								
	P3	■	■	■	■	■	■	■	■								
	P4	■	■	■	■	■	■	■	■								
M	M1	■	■	■	■	■	■	■	■								
	M2	■	■	■	■	■	■	■	■								
	M3	■	■	■	■	■	■	■	■								
	M4	■	■	■	■	■	■	■	■								
K	K1	■	■	■	■	■	■	■	■								
	K2	■	■	■	■	■	■	■	■								
	K3	■	■	■	■	■	■	■	■								
	K4	■	■	■	■	■	■	■	■								
	K5	■	■	■	■	■	■	■	■								
N	N1	■	■	■	■	■	■	■	■								
	N2	■	■	■	■	■	■	■	■								
	N3	■	■	■	■	■	■	■	■								
	N4	■	■	■	■	■	■	■	■								
	N5	■	■	■	■	■	■	■	■								
S	S1	■	■	■	■	■	■	■	■								
	S2	■	■	■	■	■	■	■	■								
	S3	■	■	■	■	■	■	■	■								
	S4	■	■	■	■	■	■	■	■								
H	H1																
	H2																
	H3																
	H4																

A321



Foret HSS de longueur intermédiaire, finition vapeur et bronze

Foret de conception robuste avec queue à trois méplats pour les trous de profondeur moyenne. Adapté en premier lieu pour les utilisations manuelles et les perceuses à colonne. Les trois méplats sur la queue permettent un serrage sans glissement dans le mandrin. La pointe en croix auto-centrante à 135° réduit la force de poussée et la finition de surface vapeur et bronze améliore le pouvoir lubrifiant.

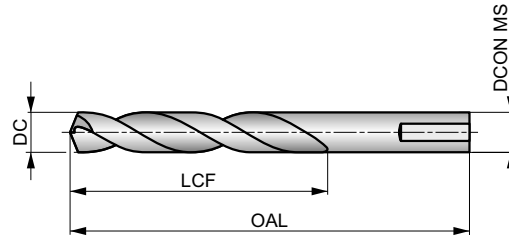

HSS	DORMER	3.5xD
135°	ST Bronze	
R	DC h8	

Adéquation du groupe de matériaux de la pièce, valeurs de départ pour la vitesse de coupe (m/min) et code Alpha d'avance. Les tableaux d'avances par tour se trouvent à partir de la page 274.

P1.1 ■ 33 H	P1.2 ■ 37 H	P1.3 ■ 38 H	P2.1 ■ 28 H	P2.2 ■ 25 F	P2.3 ■ 22 E	P3.1 ■ 19 F	P3.2 ■ 15 F	P3.3 ■ 13 E	P4.1 ■ 11 F	P4.2 ■ 10 E	P4.3 ■ 8 D	M1.1 ■ 21 E	M1.2 ■ 17 E
M2.1 ■ 18 E	M2.2 ■ 15 E	M3.1 ■ 9 G	M3.2 ■ 8 G	M3.3 ■ 7 G	M4.1 ■ 9 C	K1.1 ■ 30 H	K1.2 ■ 22 F	K1.3 ■ 17 F	K2.1 ■ 25 E	K2.2 ■ 20 E	K2.3 ■ 16 E	K3.1 ■ 22 E	K3.2 ■ 17 E
K3.3 ■ 13 E	K4.1 ■ 20 E	K4.2 ■ 15 E	K4.3 ■ 11 E	K4.4 ■ 10 E	K4.5 ■ 8 E	K5.1 ■ 23 E	K5.2 ■ 17 E	K5.3 ■ 13 E	N1.1 ■ 33 J	N1.2 ■ 25 J	N1.3 ■ 17 I	N2.1 ■ 42 H	N2.2 ■ 37 H
N2.3 ■ 27 H	N3.1 ■ 59 H	N3.2 ■ 35 I	N3.3 ■ 18 G	N4.1 ■ 30 J	N4.2 ■ 28 H	N4.3 ■ 14 F	S1.1 ■ 23 E	S1.2 ■ 12 D	S1.3 ■ 6 B	S2.1 ■ 8 E	S2.2 ■ 4 A	S3.1 ■ 6 E	S3.2 ■ 3 A
S4.1 ■ 5 E	S4.2 ■ 2 A												

Product	DC (mm)	DC (inch)	LCF (mm)	OAL (mm)	DCON MS (mm)
A3213.0	3.00	0.1180	37.0	64.0	3.00
A3213.3	3.30	0.1300	40.0	67.0	3.30
A3213.4	3.40	0.1340	40.0	67.0	3.40
A3213.5	3.50	0.1380	40.0	67.0	3.50
A3214.0	4.00	0.1580	47.0	74.0	4.00
A3214.1	4.10	0.1610	47.0	74.0	4.10
A3214.2	4.20	0.1650	47.0	74.0	4.20
A3214.3	4.30	0.1690	47.0	74.0	4.30
A3214.5	4.50	0.1770	49.0	77.0	4.50
A3214.9	4.90	0.1930	50.0	80.0	4.90
A3215.0	5.00	0.1970	50.0	80.0	5.00
A3215.1	5.10	0.2010	50.0	80.0	5.10
A3215.3	5.30	0.2090	52.0	84.0	5.30
A3215.5	5.50	0.2170	52.0	84.0	5.50
A3216.0	6.00	0.2360	52.0	90.0	6.00
A3216.3	6.30	0.2480	52.0	90.0	6.30
A3216.5	6.50	0.2560	55.0	93.0	6.50

Product	DC (mm)	DC (inch)	LCF (mm)	OAL (mm)	DCON MS (mm)
A3216.8	6.80	0.2680	59.0	97.0	6.80
A3217.0	7.00	0.2760	59.0	97.0	7.00
A3217.3	7.30	0.2870	62.0	100.0	7.30
A3217.5	7.50	0.2950	62.0	100.0	7.50
A3218.0	8.00	0.3150	67.0	105.0	8.00
A3218.5	8.50	0.3350	68.0	107.0	8.50
A3219.0	9.00	0.3540	70.0	108.0	9.00
A3219.5	9.50	0.3740	70.0	110.0	9.50
A32110.0	10.00	0.3940	74.0	113.0	10.00
A32110.3	10.30	0.4060	74.0	113.0	10.30
A32110.5	10.50	0.4130	75.0	115.0	10.50
A32111.0	11.00	0.4330	77.0	117.0	11.00
A32111.5	11.50	0.4530	79.0	120.0	11.50
A32112.0	12.00	0.4720	85.0	126.0	12.00
A32112.5	12.50	0.4920	88.0	130.0	12.50
A32113.0	13.00	0.5120	88.0	130.0	13.00

A100



Foret court en HSS, finition avec traitement vapeur

Un excellent foret polyvalent avec une pointe conventionnelle de 118° qui offre de la résistance et est facile à réaffûter, ce qui le rend très rentable. Utilisable pour le perçage manuel et sur machines. La finition avec traitement vapeur retient le fluide de coupe et empêche le collage des copeaux sur l'outil. Convient à de nombreux matériaux.

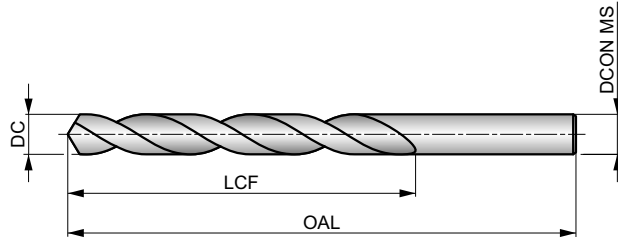

HSS	DIN 338	4×D
118°	ST	
λ20-35°	R	DC h8

Adéquation du groupe de matériaux de la pièce, valeurs de départ pour la vitesse de coupe (m/min) et code Alpha d'avance. Les tableaux d'avances par tour se trouvent à partir de la page 274.

P1.1 ■ 33 H	P1.2 ■ 37 H	P1.3 ■ 38 H	P2.1 ■ 28 H	P2.2 ■ 25 F	P2.3 ■ 22 E	P3.1 ■ 19 F	P3.2 ■ 15 F	P3.3 ■ 13 E	P4.1 ■ 11 F	P4.2 ■ 10 E	P4.3 ■ 8 D	M1.1 ■ 21 E	M1.2 ■ 17 E
M2.1 ■ 18 E	M2.2 ■ 15 E	M3.1 ■ 9 G	M3.2 ■ 8 G	M3.3 ■ 7 G	M4.1 ■ 9 C	K1.1 ■ 30 H	K1.2 ■ 22 F	K1.3 ■ 17 F	K2.1 ■ 25 E	K2.2 ■ 20 E	K2.3 ■ 16 E	K3.1 ■ 22 E	K3.2 ■ 17 E
K3.3 ■ 13 E	K4.1 ■ 20 E	K4.2 ■ 15 E	K4.3 ■ 11 E	K4.4 ■ 10 E	K4.5 ■ 8 E	K5.1 ■ 23 E	K5.2 ■ 17 E	K5.3 ■ 13 E	N1.1 ■ 33 J	N1.2 ■ 25 J	N1.3 ■ 17 I	N2.1 ■ 42 H	N2.2 ■ 37 H
N2.3 ■ 27 H	N3.1 ■ 59 H	N3.2 ■ 35 I	N3.3 ■ 18 G	N4.1 ■ 30 J	N4.2 ■ 28 H	N4.3 ■ 14 F	S1.1 ■ 23 E	S1.2 ■ 12 D	S1.3 ■ 6 B	S2.1 ■ 8 E	S2.2 ■ 4 A	S3.1 ■ 6 E	S3.2 ■ 3 A
S4.1 ■ 5 E	S4.2 ■ 2 A												

DC ≤ 1mm; 3/64"; N60. Brillant.
Les produits de cette série sont également disponibles en coffret. Voir A190 ou A191.

Product	DC (inch)	DC (mm)	DC (inch)	LCF (mm)	OAL (mm)	DCON MS (mm)
A100.2	—	0.20	0.0079	2.5	19.0	0.20
A100.25	—	0.25	0.0098	3.0	19.0	0.25
A100.3	—	0.30	0.0118	3.0	19.0	0.30
A100.32	—	0.32	0.0126	4.0	19.0	0.32
A100N80	N80	0.34	0.0135	4.0	19.0	0.34
A100.35	—	0.35	0.0138	4.0	19.0	0.35
A100N79	N79	0.37	0.0145	4.0	19.0	0.37
A100.38	—	0.38	0.0150	4.0	19.0	0.38
A1001/64	1/64	0.40	0.0156	5.0	20.0	0.40
A100.4	—	0.40	0.0157	5.0	20.0	0.40
A100N78	N78	0.41	0.0160	5.0	20.0	0.41
A100.42	—	0.42	0.0165	5.0	20.0	0.42
A100.45	—	0.45	0.0177	5.0	20.0	0.45
A100N77	N77	0.46	0.0180	5.0	20.0	0.46
A100.48	—	0.48	0.0189	5.0	20.0	0.48
A100.5	—	0.50	0.0197	6.0	22.0	0.50
A100N76	N76	0.51	0.0200	6.0	22.0	0.51
A100.52	—	0.52	0.0205	6.0	22.0	0.52
A100N75	N75	0.53	0.0210	6.0	22.0	0.53
A100.55	—	0.55	0.0217	7.0	24.0	0.55
A100N74	N74	0.57	0.0225	7.0	24.0	0.57
A100.58	—	0.58	0.0228	7.0	24.0	0.58

Product	DC (inch)	DC (mm)	DC (inch)	LCF (mm)	OAL (mm)	DCON MS (mm)
A100.6	—	0.60	0.0236	7.0	24.0	0.60
A100N73	N73	0.61	0.0240	8.0	26.0	0.61
A100.62	—	0.62	0.0244	8.0	26.0	0.62
A100N72	N72	0.64	0.0250	8.0	26.0	0.64
A100.65	—	0.65	0.0256	8.0	26.0	0.65
A100N71	N71	0.66	0.0260	8.0	26.0	0.66
A100.68	—	0.68	0.0268	9.0	28.0	0.68
A100.7	—	0.70	0.0276	9.0	28.0	0.70
A100N70	N70	0.71	0.0280	9.0	28.0	0.71
A100.72	—	0.72	0.0283	9.0	28.0	0.72
A100N69	N69	0.74	0.0292	9.0	28.0	0.74
A100.75	—	0.75	0.0295	9.0	28.0	0.75
A100.78	—	0.78	0.0307	10.0	30.0	0.78
A1001/32	1/32	0.79	0.0313	10.0	30.0	0.79
A100N68	N68	0.79	0.0310	10.0	30.0	0.79
A100.8	—	0.80	0.0315	10.0	30.0	0.80
A100N67	N67	0.81	0.0320	10.0	30.0	0.81
A100.82	—	0.82	0.0323	10.0	30.0	0.82
A100N66	N66	0.84	0.0330	10.0	30.0	0.84
A100.85	—	0.85	0.0335	10.0	30.0	0.85
A100.88	—	0.88	0.0346	11.0	32.0	0.88
A100N65	N65	0.89	0.0350	11.0	32.0	0.89

Product	DC	DC	DC	LCF	OAL	DCON MS
	(inch)	(mm)	(inch)	(mm)	(mm)	(mm)
A100.9	–	0.90	0.0354	11.0	32.0	0.90
A100N64	N64	0.91	0.0360	11.0	32.0	0.91
A100.92	–	0.92	0.0362	11.0	32.0	0.92
A100N63	N63	0.94	0.0370	11.0	32.0	0.94
A100.95	–	0.95	0.0374	11.0	32.0	0.95
A100N62	N62	0.97	0.0380	12.0	34.0	0.97
A100.98	–	0.98	0.0386	12.0	34.0	0.98
A100N61	N61	0.99	0.0390	12.0	34.0	0.99
A1001.0	–	1.00	0.0394	12.0	34.0	1.00
A100N60	N60	1.02	0.0400	12.0	34.0	1.02
A100N59	N59	1.04	0.0410	12.0	34.0	1.04
A1001.05	–	1.05	0.0413	12.0	34.0	1.05
A100N58	N58	1.07	0.0420	14.0	36.0	1.07
A100N57	N57	1.09	0.0430	14.0	36.0	1.09
A1001.1	–	1.10	0.0433	14.0	36.0	1.10
A1001.15	–	1.15	0.0453	14.0	36.0	1.15
A100N56	N56	1.18	0.0465	14.0	36.0	1.18
A1003/64	3/64	1.19	0.0469	16.0	38.0	1.19
A1001.2	–	1.20	0.0472	16.0	38.0	1.20
A1001.25	–	1.25	0.0492	16.0	38.0	1.25
A1001.3	–	1.30	0.0512	16.0	38.0	1.30
A100N55	N55	1.32	0.0520	16.0	38.0	1.32
A1001.35	–	1.35	0.0531	18.0	40.0	1.35
A1001.4	–	1.40	0.0551	18.0	40.0	1.40
A100N54	N54	1.40	0.0550	18.0	40.0	1.40
A1001.45	–	1.45	0.0571	18.0	40.0	1.45
A1001.5	–	1.50	0.0591	18.0	40.0	1.50
A100N53	N53	1.51	0.0595	20.0	43.0	1.51
A1001.55	–	1.55	0.0610	20.0	43.0	1.55
A1001/16	1/16	1.59	0.0625	20.0	43.0	1.59
A1001.6	–	1.60	0.0630	20.0	43.0	1.60
A100N52	N52	1.61	0.0635	20.0	43.0	1.61
A1001.65	–	1.65	0.0650	20.0	43.0	1.65
A1001.7	–	1.70	0.0669	20.0	43.0	1.70
A100N51	N51	1.70	0.0670	22.0	46.0	1.70
A1001.75	–	1.75	0.0689	22.0	46.0	1.75
A100N50	N50	1.78	0.0700	22.0	46.0	1.78
A1001.8	–	1.80	0.0709	22.0	46.0	1.80
A1001.85	–	1.85	0.0728	22.0	46.0	1.85
A100N49	N49	1.85	0.0730	22.0	46.0	1.85
A1001.9	–	1.90	0.0748	22.0	46.0	1.90
A100N48	N48	1.93	0.0760	24.0	49.0	1.93
A1001.95	–	1.95	0.0768	24.0	49.0	1.95
A1005/64	5/64	1.98	0.0781	24.0	49.0	1.98
A100N47	N47	1.99	0.0785	24.0	49.0	1.99
A1002.0	–	2.00	0.0787	24.0	49.0	2.00
A1002.05	–	2.05	0.0807	24.0	49.0	2.05
A100N46	N46	2.06	0.0810	24.0	49.0	2.06
A100N45	N45	2.08	0.0820	24.0	49.0	2.08
A1002.1	–	2.10	0.0827	24.0	49.0	2.10
A1002.15	–	2.15	0.0846	27.0	53.0	2.15
A100N44	N44	2.18	0.0860	27.0	53.0	2.18
A1002.2	–	2.20	0.0866	27.0	53.0	2.20
A1002.25	–	2.25	0.0886	27.0	53.0	2.25
A100N43	N43	2.26	0.0890	27.0	53.0	2.26
A1002.3	–	2.30	0.0906	27.0	53.0	2.30
A1002.35	–	2.35	0.0925	27.0	53.0	2.35
A1003/32	3/32	2.38	0.0938	30.0	57.0	2.38
A100N42	N42	2.38	0.0935	30.0	57.0	2.38
A1002.4	–	2.40	0.0945	30.0	57.0	2.40
A100N41	N41	2.44	0.0960	30.0	57.0	2.44
A1002.45	–	2.45	0.0965	30.0	57.0	2.45

Product	DC	DC	DC	LCF	OAL	DCON MS
	(inch)	(mm)	(inch)	(mm)	(mm)	(mm)
A100N40	N40	2.49	0.0980	30.0	57.0	2.49
A1002.5	–	2.50	0.0984	30.0	57.0	2.50
A100N39	N39	2.53	0.0995	30.0	57.0	2.53
A1002.55	–	2.55	0.1004	30.0	57.0	2.55
A100N38	N38	2.58	0.1015	30.0	57.0	2.58
A1002.6	–	2.60	0.1024	30.0	57.0	2.60
A100N37	N37	2.64	0.1040	30.0	57.0	2.64
A1002.65	–	2.65	0.1043	30.0	57.0	2.65
A1002.7	–	2.70	0.1063	33.0	61.0	2.70
A100N36	N36	2.71	0.1065	33.0	61.0	2.71
A1002.75	–	2.75	0.1083	33.0	61.0	2.75
A1007/64	7/64	2.78	0.1094	33.0	61.0	2.78
A100N35	N35	2.79	0.1100	33.0	61.0	2.79
A1002.8	–	2.80	0.1102	33.0	61.0	2.80
A100N34	N34	2.82	0.1110	33.0	61.0	2.82
A1002.85	–	2.85	0.1122	33.0	61.0	2.85
A100N33	N33	2.87	0.1130	33.0	61.0	2.87
A1002.9	–	2.90	0.1142	33.0	61.0	2.90
A1002.95	–	2.95	0.1161	33.0	61.0	2.95
A100N32	N32	2.95	0.1160	33.0	61.0	2.95
A1003.0	–	3.00	0.1181	33.0	61.0	3.00
A100N31	N31	3.05	0.1200	36.0	65.0	3.05
A1003.1	–	3.10	0.1220	36.0	65.0	3.10
A1003.15	–	3.15	0.1240	36.0	65.0	3.15
A1001/8	1/8	3.18	0.1250	36.0	65.0	3.18
A1003.2	–	3.20	0.1260	36.0	65.0	3.20
A1003.25	–	3.25	0.1280	36.0	65.0	3.25
A100N30	N30	3.26	0.1285	36.0	65.0	3.26
A1003.3	–	3.30	0.1299	36.0	65.0	3.30
A1003.4	–	3.40	0.1339	39.0	70.0	3.40
A100N29	N29	3.45	0.1360	39.0	70.0	3.45
A1003.5	–	3.50	0.1378	39.0	70.0	3.50
A1009/64	9/64	3.57	0.1406	39.0	70.0	3.57
A100N28	N28	3.57	0.1405	39.0	70.0	3.57
A1003.6	–	3.60	0.1417	39.0	70.0	3.60
A100N27	N27	3.66	0.1440	39.0	70.0	3.66
A1003.7	–	3.70	0.1457	39.0	70.0	3.70
A100N26	N26	3.73	0.1470	39.0	70.0	3.73
A1003.75	–	3.75	0.1476	39.0	70.0	3.75
A1003.8	–	3.80	0.1496	43.0	75.0	3.80
A100N25	N25	3.80	0.1495	43.0	75.0	3.80
A100N24	N24	3.86	0.1520	43.0	75.0	3.86
A1003.9	–	3.90	0.1535	43.0	75.0	3.90
A100N23	N23	3.91	0.1540	43.0	75.0	3.91
A1005/32	5/32	3.97	0.1563	43.0	75.0	3.97
A100N22	N22	3.99	0.1570	43.0	75.0	3.99
A1004.0	–	4.00	0.1575	43.0	75.0	4.00
A100N21	N21	4.04	0.1590	43.0	75.0	4.04
A100N20	N20	4.09	0.1610	43.0	75.0	4.09
A1004.1	–	4.10	0.1614	43.0	75.0	4.10
A1004.2	–	4.20	0.1654	43.0	75.0	4.20
A100N19	N19	4.22	0.1660	43.0	75.0	4.22
A1004.25	–	4.25	0.1673	43.0	75.0	4.25
A1004.3	–	4.30	0.1693	47.0	80.0	4.30
A100N18	N18	4.31	0.1695	47.0	80.0	4.31
A10011/64	11/64	4.37	0.1719	47.0	80.0	4.37
A100N17	N17	4.39	0.1730	47.0	80.0	4.39
A1004.4	–	4.40	0.1732	47.0	80.0	4.40
A1004.5	–	4.50	0.1772	47.0	80.0	4.50
A100N16	N16	4.50	0.1770	47.0	80.0	4.50
A100N15	N15	4.57	0.1800	47.0	80.0	4.57
A1004.6	–	4.60	0.1811	47.0	80.0	4.60



Product	DC	DC	DC	LCF	OAL	DCON MS
	(inch)	(mm)	(inch)	(mm)	(mm)	(mm)
A100N14	N14	4.62	0.1820	47.0	80.0	4.62
A1004.7	–	4.70	0.1850	47.0	80.0	4.70
A100N13	N13	4.70	0.1850	47.0	80.0	4.70
A1004.75	–	4.75	0.1870	47.0	80.0	4.75
A1003/16	3/16	4.76	0.1875	52.0	86.0	4.76
A1004.8	–	4.80	0.1890	52.0	86.0	4.80
A100N12	N12	4.80	0.1890	52.0	86.0	4.80
A100N11	N11	4.85	0.1910	52.0	86.0	4.85
A1004.9	–	4.90	0.1929	52.0	86.0	4.90
A100N10	N10	4.92	0.1935	52.0	86.0	4.92
A100N9	N9	4.98	0.1960	52.0	86.0	4.98
A1005.0	–	5.00	0.1969	52.0	86.0	5.00
A100N8	N8	5.06	0.1990	52.0	86.0	5.06
A1005.1	–	5.10	0.2008	52.0	86.0	5.10
A100N7	N7	5.11	0.2010	52.0	86.0	5.11
A10013/64	13/64	5.16	0.2031	52.0	86.0	5.16
A100N6	N6	5.18	0.2040	52.0	86.0	5.18
A1005.2	–	5.20	0.2047	52.0	86.0	5.20
A100N5	N5	5.22	0.2055	52.0	86.0	5.22
A1005.25	–	5.25	0.2067	52.0	86.0	5.25
A1005.3	–	5.30	0.2087	52.0	86.0	5.30
A100N4	N4	5.31	0.2090	57.0	93.0	5.31
A1005.4	–	5.40	0.2126	57.0	93.0	5.40
A100N3	N3	5.41	0.2130	57.0	93.0	5.41
A1005.5	–	5.50	0.2165	57.0	93.0	5.50
A1007/32	7/32	5.56	0.2188	57.0	93.0	5.56
A1005.6	–	5.60	0.2205	57.0	93.0	5.60
A100N2	N2	5.61	0.2210	57.0	93.0	5.61
A1005.7	–	5.70	0.2244	57.0	93.0	5.70
A1005.75	–	5.75	0.2264	57.0	93.0	5.75
A100N1	1	5.79	0.2280	57.0	93.0	5.79
A1005.8	–	5.80	0.2283	57.0	93.0	5.80
A1005.9	–	5.90	0.2323	57.0	93.0	5.90
A100A	A	5.94	0.2340	57.0	93.0	5.94
A10015/64	15/64	5.95	0.2344	57.0	93.0	5.95
A1006.0	–	6.00	0.2362	57.0	93.0	6.00
A100B	B	6.03	0.2380	63.0	101.0	6.03
A1006.1	–	6.10	0.2402	63.0	101.0	6.10
A100C	C	6.15	0.2420	63.0	101.0	6.15
A1006.2	–	6.20	0.2441	63.0	101.0	6.20
A1006.25	–	6.25	0.2461	63.0	101.0	6.25
A100D	D	6.25	0.2460	63.0	101.0	6.25
A1006.3	–	6.30	0.2480	63.0	101.0	6.30
A1001/4	1/4	6.35	0.2500	63.0	101.0	6.35
A100E	E	6.35	0.2500	63.0	101.0	6.35
A1006.4	–	6.40	0.2520	63.0	101.0	6.40
A1006.5	–	6.50	0.2559	63.0	101.0	6.50
A100F	F	6.53	0.2570	63.0	101.0	6.53
A1006.6	–	6.60	0.2598	63.0	101.0	6.60
A100G	G	6.63	0.2610	63.0	101.0	6.63
A1006.7	–	6.70	0.2638	63.0	101.0	6.70
A10017/64	17/64	6.75	0.2656	69.0	109.0	6.75
A1006.75	–	6.75	0.2657	69.0	109.0	6.75
A100H	H	6.76	0.2660	69.0	109.0	6.76
A1006.8	–	6.80	0.2677	69.0	109.0	6.80
A1006.9	–	6.90	0.2717	69.0	109.0	6.90
A100I	I	6.91	0.2720	69.0	109.0	6.91
A1007.0	–	7.00	0.2756	69.0	109.0	7.00
A100J	J	7.04	0.2770	69.0	109.0	7.04
A1007.1	–	7.10	0.2795	69.0	109.0	7.10
A1009/32	9/32	7.14	0.2813	69.0	109.0	7.14
A1007.2	–	7.20	0.2835	69.0	109.0	7.20

Product	DC	DC	DC	LCF	OAL	DCON MS
	(inch)	(mm)	(inch)	(mm)	(mm)	(mm)
A1007.25	–	7.25	0.2854	69.0	109.0	7.25
A1007.3	–	7.30	0.2874	69.0	109.0	7.30
A100L	L	7.37	0.2900	69.0	109.0	7.37
A1007.4	–	7.40	0.2913	69.0	109.0	7.40
A1007.5	–	7.50	0.2953	69.0	109.0	7.50
A10019/64	19/64	7.54	0.2969	75.0	117.0	7.54
A1007.6	–	7.60	0.2992	75.0	117.0	7.60
A100N	N	7.67	0.3020	75.0	117.0	7.67
A1007.7	–	7.70	0.3031	75.0	117.0	7.70
A1007.75	–	7.75	0.3051	75.0	117.0	7.75
A1007.8	–	7.80	0.3071	75.0	117.0	7.80
A1007.9	–	7.90	0.3110	75.0	117.0	7.90
A1005/16	5/16	7.94	0.3125	75.0	117.0	7.94
A1008.0	–	8.00	0.3150	75.0	117.0	8.00
A1000	0	8.03	0.3160	75.0	117.0	8.03
A1008.1	–	8.10	0.3189	75.0	117.0	8.10
A1008.2	–	8.20	0.3228	75.0	117.0	8.20
A1008.25	–	8.25	0.3248	75.0	117.0	8.25
A1008.3	–	8.30	0.3268	75.0	117.0	8.30
A10021/64	21/64	8.33	0.3281	75.0	117.0	8.33
A1008.4	–	8.40	0.3307	75.0	117.0	8.40
A100Q	Q	8.43	0.3320	75.0	117.0	8.43
A1008.5	–	8.50	0.3346	75.0	117.0	8.50
A1008.6	–	8.60	0.3386	81.0	125.0	8.60
A1008.7	–	8.70	0.3425	81.0	125.0	8.70
A10011/32	11/32	8.73	0.3438	81.0	125.0	8.73
A1008.75	–	8.75	0.3445	81.0	125.0	8.75
A1008.8	–	8.80	0.3465	81.0	125.0	8.80
A1008.9	–	8.90	0.3504	81.0	125.0	8.90
A1009.0	–	9.00	0.3543	81.0	125.0	9.00
A1009.1	–	9.10	0.3583	81.0	125.0	9.10
A10023/64	23/64	9.13	0.3594	81.0	125.0	9.13
A1009.2	–	9.20	0.3622	81.0	125.0	9.20
A1009.25	–	9.25	0.3642	81.0	125.0	9.25
A1009.3	–	9.30	0.3661	81.0	125.0	9.30
A100U	U	9.35	0.3680	81.0	125.0	9.35
A1009.4	–	9.40	0.3701	81.0	125.0	9.40
A1009.5	–	9.50	0.3740	81.0	125.0	9.50
A1003/8	3/8	9.52	0.3750	87.0	133.0	9.52
A1009.6	–	9.60	0.3780	87.0	133.0	9.60
A1009.7	–	9.70	0.3819	87.0	133.0	9.70
A1009.75	–	9.75	0.3839	87.0	133.0	9.75
A1009.8	–	9.80	0.3858	87.0	133.0	9.80
A1009.9	–	9.90	0.3898	87.0	133.0	9.90
A10025/64	25/64	9.92	0.3906	87.0	133.0	9.92
A10010.0	–	10.00	0.3937	87.0	133.0	10.00
A10010.1	–	10.10	0.3976	87.0	133.0	10.10
A10010.2	–	10.20	0.4016	87.0	133.0	10.20
A10010.25	–	10.25	0.4035	87.0	133.0	10.25
A10010.3	–	10.30	0.4055	87.0	133.0	10.30
A10013/32	13/32	10.32	0.4063	87.0	133.0	10.32
A10010.4	–	10.40	0.4094	87.0	133.0	10.40
A10010.5	–	10.50	0.4134	87.0	133.0	10.50
A10010.6	–	10.60	0.4173	87.0	133.0	10.60
A10010.7	–	10.70	0.4213	94.0	142.0	10.70
A10027/64	27/64	10.72	0.4219	94.0	142.0	10.72
A10010.75	–	10.75	0.4232	94.0	142.0	10.75
A10010.8	–	10.80	0.4252	94.0	142.0	10.80
A10010.9	–	10.90	0.4291	94.0	142.0	10.90
A10011.0	–	11.00	0.4331	94.0	142.0	11.00
A10011.1	–	11.10	0.4370	94.0	142.0	11.10
A1007/16	7/16	11.11	0.4375	94.0	142.0	11.11



Product	DC	DC	DC	LCF	OAL	D CON MS
	(inch)	(mm)	(inch)	(mm)	(mm)	(mm)
A10011.2	–	11.20	0.4409	94.0	142.0	11.20
A10011.25	–	11.25	0.4429	94.0	142.0	11.25
A10011.3	–	11.30	0.4449	94.0	142.0	11.30
A10011.4	–	11.40	0.4488	94.0	142.0	11.40
A10011.5	–	11.50	0.4528	94.0	142.0	11.50
A10029/64	29/64	11.51	0.4531	94.0	142.0	11.51
A10011.6	–	11.60	0.4567	94.0	142.0	11.60
A10011.7	–	11.70	0.4606	94.0	142.0	11.70
A10011.75	–	11.75	0.4626	94.0	142.0	11.75
A10011.8	–	11.80	0.4646	94.0	142.0	11.80
A10011.9	–	11.90	0.4685	101.0	151.0	11.90
A10015/32	15/32	11.91	0.4688	101.0	151.0	11.91
A10012.0	–	12.00	0.4724	101.0	151.0	12.00
A10012.1	–	12.10	0.4764	101.0	151.0	12.10
A10012.2	–	12.20	0.4803	101.0	151.0	12.20
A10012.25	–	12.25	0.4823	101.0	151.0	12.25
A10012.3	–	12.30	0.4843	101.0	151.0	12.30
A10031/64	31/64	12.30	0.4844	101.0	151.0	12.30
A10012.4	–	12.40	0.4882	101.0	151.0	12.40
A10012.5	–	12.50	0.4921	101.0	151.0	12.50
A10012.6	–	12.60	0.4961	101.0	151.0	12.60
A10012.7	–	12.70	0.5000	101.0	151.0	12.70
A1001/2	1/2	12.70	0.5000	101.0	151.0	12.70
A10012.75	–	12.75	0.5020	101.0	151.0	12.75
A10012.8	–	12.80	0.5039	101.0	151.0	12.80
A10012.9	–	12.90	0.5079	101.0	151.0	12.90
A10013.0	–	13.00	0.5118	101.0	151.0	13.00
A10033/64	33/64	13.10	0.5156	101.0	151.0	13.10
A10013.1	–	13.10	0.5157	101.0	151.0	13.10
A10013.2	–	13.20	0.5197	101.0	151.0	13.20
A10013.25	–	13.25	0.5217	108.0	160.0	13.25
A10013.3	–	13.30	0.5236	108.0	160.0	13.30
A10013.4	–	13.40	0.5276	108.0	160.0	13.40

Product	DC	DC	DC	LCF	OAL	D CON MS
	(inch)	(mm)	(inch)	(mm)	(mm)	(mm)
A10017/32	17/32	13.49	0.5313	108.0	160.0	13.49
A10013.5	–	13.50	0.5315	108.0	160.0	13.50
A10013.6	–	13.60	0.5354	108.0	160.0	13.60
A10013.7	–	13.70	0.5394	108.0	160.0	13.70
A10013.75	–	13.75	0.5413	108.0	160.0	13.75
A10013.8	–	13.80	0.5433	108.0	160.0	13.80
A10035/64	35/64	13.89	0.5469	108.0	160.0	13.89
A10013.9	–	13.90	0.5472	108.0	160.0	13.90
A10014.0	–	14.00	0.5512	108.0	160.0	14.00
A10014.25	–	14.25	0.5610	114.0	169.0	14.25
A1009/16	9/16	14.29	0.5625	114.0	169.0	14.29
A10014.5	–	14.50	0.5709	114.0	169.0	14.50
A10037/64	37/64	14.68	0.5781	114.0	169.0	14.68
A10014.75	–	14.75	0.5807	114.0	169.0	14.75
A10015.0	–	15.00	0.5906	114.0	169.0	15.00
A10019/32	19/32	15.08	0.5938	120.0	178.0	15.08
A10015.25	–	15.25	0.6004	120.0	178.0	15.25
A10015.5	–	15.50	0.6102	120.0	178.0	15.50
A10015.75	–	15.75	0.6201	120.0	178.0	15.75
A1005/8	5/8	15.88	0.6250	120.0	178.0	15.88
A10016.0	–	16.00	0.6299	120.0	178.0	16.00
A10041/64	41/64	16.27	0.6406	125.0	184.0	16.27
A10016.5	–	16.50	0.6496	125.0	184.0	16.50
A10021/32	21/32	16.67	0.6563	125.0	184.0	16.67
A10017.0	–	17.00	0.6693	125.0	184.0	17.00
A10011/16	11/16	17.46	0.6875	130.0	191.0	17.46
A10017.5	–	17.50	0.6890	130.0	191.0	17.50
A10018.0	–	18.00	0.7087	130.0	191.0	18.00
A10018.5	–	18.50	0.7283	135.0	198.0	18.50
A10019.0	–	19.00	0.7480	135.0	198.0	19.00
A10019.5	–	19.50	0.7677	140.0	205.0	19.50
A10020.0	–	20.00	0.7874	140.0	205.0	20.00

A101



Foret court à gauche en HSS, finition avec traitement vapeur

Foret polyvalent à gauche avec finition traitement vapeur pour le perçage à la main et sur machines. La pointe conventionnelle à 118° est résistante et facile à réaffûter ce qui la rend très rentable. La finition avec traitement vapeur retient le liquide de coupe et empêche le collage des copeaux sur l'outil. Convient pour le perçage de nombreux matériaux.

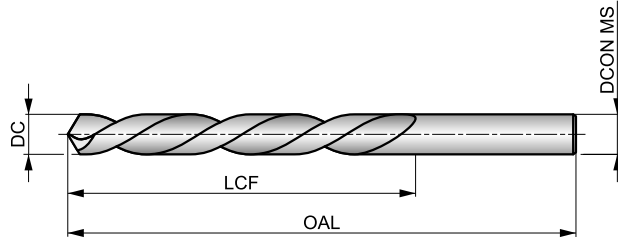

HSS	DIN 338	4×D
118°	ST	
λ 20-35°	L	DC h8

Adéquation du groupe de matériaux de la pièce, valeurs de départ pour la vitesse de coupe (m/min) et code Alpha d'avance. Les tableaux d'avances par tour se trouvent à partir de la page 274.

P1.1 ■ 33 H	P1.2 ■ 37 H	P1.3 ■ 38 H	P2.1 ■ 28 H	P2.2 ■ 25 F	P2.3 ■ 22 E	P3.1 ■ 19 F	P3.2 ■ 15 F	P3.3 ■ 13 E	P4.1 ■ 11 F	P4.2 ■ 10 E	P4.3 ■ 8 D	M1.1 ■ 21 E	M1.2 ■ 17 E
M2.1 ■ 18 E	M2.2 ■ 15 E	M3.1 ■ 9 G	M3.2 ■ 8 G	M3.3 ■ 7 G	M4.1 ■ 9 C	K1.1 ■ 30 H	K1.2 ■ 22 F	K1.3 ■ 17 F	K2.1 ■ 25 E	K2.2 ■ 20 E	K2.3 ■ 16 E	K3.1 ■ 22 E	K3.2 ■ 17 E
K3.3 ■ 13 E	K4.1 ■ 20 E	K4.2 ■ 15 E	K4.3 ■ 11 E	K4.4 ■ 10 E	K4.5 ■ 8 E	K5.1 ■ 23 E	K5.2 ■ 17 E	K5.3 ■ 13 E	N1.1 ■ 33 J	N1.2 ■ 25 J	N1.3 ■ 17 I	N2.1 ■ 42 H	N2.2 ■ 37 H
N2.3 ■ 27 H	N3.1 ■ 59 H	N3.2 ■ 35 I	N3.3 ■ 18 G	N4.1 ■ 30 J	N4.2 ■ 28 H	N4.3 ■ 14 F	S1.1 ■ 23 E	S1.2 ■ 12 D	S1.3 ■ 6 B	S2.1 ■ 8 E	S2.2 ■ 4 A	S3.1 ■ 6 E	S3.2 ■ 3 A
S4.1 ■ 5 E	S4.2 ■ 2 A												

DC <= 3mm Brillant.

Product	DC (mm)	DC (inch)	LCF (mm)	OAL (mm)	DCON MS (mm)
A1011.0	1.00	0.0394	12.0	34.0	1.00
A1011.1	1.10	0.0433	14.0	36.0	1.10
A1011.2	1.20	0.0472	16.0	38.0	1.20
A1011.25	1.25	0.0492	16.0	38.0	1.25
A1011.3	1.30	0.0512	16.0	38.0	1.30
A1011.4	1.40	0.0551	18.0	40.0	1.40
A1011.5	1.50	0.0591	18.0	40.0	1.50
A1011.6	1.60	0.0630	20.0	43.0	1.60
A1011.7	1.70	0.0669	20.0	43.0	1.70
A1011.8	1.80	0.0709	22.0	46.0	1.80
A1011.9	1.90	0.0748	22.0	46.0	1.90
A1012.0	2.00	0.0787	24.0	49.0	2.00
A1012.1	2.10	0.0827	24.0	49.0	2.10
A1012.2	2.20	0.0866	27.0	53.0	2.20
A1012.4	2.40	0.0945	30.0	57.0	2.40
A1012.5	2.50	0.0984	30.0	57.0	2.50
A1012.6	2.60	0.1024	30.0	57.0	2.60
A1012.7	2.70	0.1063	33.0	61.0	2.70
A1012.8	2.80	0.1102	33.0	61.0	2.80
A1012.9	2.90	0.1142	33.0	61.0	2.90
A1013.0	3.00	0.1181	33.0	61.0	3.00
A1013.2	3.20	0.1260	36.0	65.0	3.20

Product	DC (mm)	DC (inch)	LCF (mm)	OAL (mm)	DCON MS (mm)
A1013.3	3.30	0.1299	36.0	65.0	3.30
A1013.5	3.50	0.1378	39.0	70.0	3.50
A1013.8	3.80	0.1496	43.0	75.0	3.80
A1014.0	4.00	0.1575	43.0	75.0	4.00
A1014.2	4.20	0.1654	43.0	75.0	4.20
A1014.5	4.50	0.1772	47.0	80.0	4.50
A1014.8	4.80	0.1890	52.0	86.0	4.80
A1015.0	5.00	0.1969	52.0	86.0	5.00
A1015.1	5.10	0.2008	52.0	86.0	5.10
A1015.2	5.20	0.2047	52.0	86.0	5.20
A1015.5	5.50	0.2165	57.0	93.0	5.50
A1016.0	6.00	0.2362	57.0	93.0	6.00
A1016.5	6.50	0.2559	63.0	101.0	6.50
A1017.0	7.00	0.2756	69.0	109.0	7.00
A1017.5	7.50	0.2953	69.0	109.0	7.50
A1018.0	8.00	0.3150	75.0	117.0	8.00
A1018.5	8.50	0.3346	75.0	117.0	8.50
A1019.0	9.00	0.3543	81.0	125.0	9.00
A10110.0	10.00	0.3937	87.0	133.0	10.00
A10111.0	11.00	0.4331	94.0	142.0	11.00
A10112.0	12.00	0.4724	101.0	151.0	12.00

A170



Foret en HSS à queue réduite, finition avec traitement vapeur

Foret à queue cylindrique de 1/2 pouce (12,7 mm) permettant, même avec un grand diamètre de coupe, d'être serré dans des outils électriques conventionnels et portatifs. Une pointe à 118° facilite le réaffûtage. La finition avec traitement vapeur retient le fluide de coupe et empêche le collage des copeaux sur l'outil. Convient pour percer de nombreux matériaux.

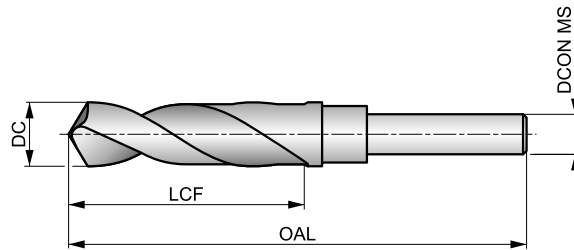

HSS	DORMER	4xD
118°	ST	
λ 20-35°	R	DC h8

Adéquation du groupe de matériaux de la pièce, valeurs de départ pour la vitesse de coupe (m/min) et code Alpha d'avance. Les tableaux d'avances par tour se trouvent à partir de la page 274.

P1.1 ■ 33 H	P1.2 ■ 37 H	P1.3 ■ 38 H	P2.1 ■ 28 H	P2.2 ■ 25 F	P2.3 ■ 22 D	P3.1 ■ 19 E	P3.2 ■ 15 E	P3.3 ■ 13 D	P4.1 ■ 11 E	P4.2 ■ 10 D	P4.3 ■ 8 C	M1.1 ■ 21 D	M1.2 ■ 17 D
M2.1 ■ 18 D	M2.2 ■ 15 D	M3.1 ■ 8 F	M3.2 ■ 7 F	M3.3 ■ 6 F	M4.1 ■ 7 B	K1.1 ■ 27 H	K1.2 ■ 20 E	K1.3 ■ 15 E	K2.1 ■ 23 D	K2.2 ■ 19 D	K2.3 ■ 15 D	K3.1 ■ 21 D	K3.2 ■ 16 D
K3.3 ■ 13 D	K4.1 ■ 19 D	K4.2 ■ 14 D	K4.3 ■ 11 D	K4.4 ■ 9 D	K4.5 ■ 8 D	K5.1 ■ 22 D	K5.2 ■ 16 D	K5.3 ■ 13 D	N1.1 ■ 33 I	N1.2 ■ 25 I	N1.3 ■ 17 H	N2.1 ■ 42 G	N2.2 ■ 37 G
N2.3 ■ 27 G	N3.1 ■ 56 G	N3.2 ■ 33 H	N3.3 ■ 17 F	N4.1 ■ 30 I	N4.2 ■ 28 G	N4.3 ■ 14 E	S1.1 ■ 17 E	S1.2 ■ 9 C	S1.3 ■ 5 A	S2.1 ■ 5 D	S2.2 ■ 4 A	S3.1 ■ 4 D	S3.2 ■ 3 A
S4.1 ■ 3 D	S4.2 ■ 2 A												

Product	DC	DC	DC	LCF	OAL	LCF	OAL	DCON MS
	(inch)	(mm)	(inch)	(inch)	(inch)	(mm)	(mm)	
A17013.0	–	13.00	0.5118	–	–	83.0	156.0	12.70
A17033/64	33/64	13.10	0.5156	3.1/8	6"	79.4	152.4	12.70
A17017/32	17/32	13.49	0.5313	3.1/8	6"	79.4	152.4	12.70
A17013.5	–	13.50	0.5315	–	–	83.0	156.0	12.70
A17035/64	35/64	13.89	0.5469	3.1/8	6"	79.4	152.4	12.70
A17014.0	–	14.00	0.5512	–	–	83.0	156.0	12.70
A1709/16	9/16	14.29	0.5625	3.1/8	6"	79.4	152.4	12.70
A17014.5	–	14.50	0.5709	–	–	83.0	156.0	12.70
A17037/64	37/64	14.68	0.5781	3.1/8	6"	79.4	152.4	12.70
A17015.0	–	15.00	0.5906	–	–	83.0	156.0	12.70
A17019/32	19/32	15.08	0.5938	3.1/8	6"	79.4	152.4	12.70
A17039/64	39/64	15.48	0.6094	3.1/8	6"	79.4	152.4	12.70
A17015.5	–	15.50	0.6102	–	–	83.0	156.0	12.70
A1705/8	5/8	15.88	0.6250	3.1/8	6"	79.4	152.4	12.70
A17016.0	–	16.00	0.6299	–	–	84.0	157.0	12.70
A17041/64	41/64	16.27	0.6406	3.1/8	6"	79.4	152.4	12.70
A17016.5	–	16.50	0.6496	–	–	84.0	157.0	12.70
A17021/32	21/32	16.67	0.6563	3.1/8	6"	79.4	152.4	12.70
A17017.0	–	17.00	0.6693	–	–	84.0	157.0	12.70
A17043/64	43/64	17.07	0.6719	3.1/8	6"	79.4	152.4	12.70
A17011/16	11/16	17.46	0.6875	3.1/8	6"	79.4	152.4	12.70
A17017.5	–	17.50	0.6890	–	–	84.0	157.0	12.70
A17045/64	45/64	17.86	0.7031	3.1/8	6"	79.4	152.4	12.70
A17018.0	–	18.00	0.7087	–	–	84.0	157.0	12.70



Product	DC	DC	DC	LCF	OAL	LCF	OAL	DCON MS
	(inch)	(mm)	(inch)	(inch)	(inch)	(mm)	(mm)	(mm)
A17023/32	23/32	18.26	0.7188	3.1/8	6"	79.4	152.4	12.70
A17018.5	–	18.50	0.7283	–	–	84.0	157.0	12.70
A17047/64	47/64	18.65	0.7344	3.1/8	6"	79.4	152.4	12.70
A17019.0	–	19.00	0.7480	–	–	84.0	157.0	12.70
A1703/4	3/4	19.05	0.7500	3.1/8	6"	79.4	152.4	12.70
A17049/64	49/64	19.45	0.7656	3"	6"	76.2	152.4	12.70
A17019.5	–	19.50	0.7677	–	–	81.0	158.0	12.70
A17025/32	25/32	19.84	0.7813	3"	6"	76.2	152.4	12.70
A17020.0	–	20.00	0.7874	–	–	81.0	158.0	12.70
A17051/64	51/64	20.24	0.7969	3"	6"	76.2	152.4	12.70
A17013/16	13/16	20.64	0.8125	3"	6"	76.2	152.4	12.70
A17021.0	–	21.00	0.8268	–	–	82.0	158.0	12.70
A17053/64	53/64	21.03	0.8281	3"	6"	76.2	152.4	12.70
A17027/32	27/32	21.43	0.8437	3"	6"	76.2	152.4	12.70
A17055/64	55/64	21.83	0.8594	3"	6"	76.2	152.4	12.70
A17022.0	–	22.00	0.8661	–	–	82.0	158.0	12.70
A1707/8	7/8	22.22	0.8750	3"	6"	76.2	152.4	12.70
A17023.0	–	23.00	0.9055	–	–	82.0	158.0	12.70
A17029/32	29/32	23.02	0.9063	3"	6"	76.2	152.4	12.70
A17059/64	59/64	23.42	0.9219	3"	6"	76.2	152.4	12.70
A17015/16	15/16	23.81	0.9375	3"	6"	76.2	152.4	12.70
A17024.0	–	24.00	0.9449	–	–	83.0	159.0	12.70
A17031/32	31/32	24.61	0.9688	3"	6"	76.2	152.4	12.70
A17025.0	–	25.00	0.9843	–	–	83.0	159.0	12.70
A1701	1"	25.40	1.0000	3"	6"	76.2	152.4	12.70
A1701.1/32	1.1/32	26.19	1.0313	3"	6"	76.2	152.4	12.70
A1701.1/16	1.1/16	26.99	1.0625	3"	6"	76.2	152.4	12.70
A1701.1/8	1.1/8	28.58	1.1250	3"	6"	76.2	152.4	12.70
A1701.3/16	1.3/16	30.16	1.1875	3"	6"	76.2	152.4	12.70
A1701.1/4	1.1/4	31.75	1.2500	3"	6"	76.2	152.4	12.70

A130



Foret à queue cône morse en HSS, finition avec traitement vapeur

Foret polyvalent pour les grands diamètres - jusqu'à 50,80 mm (2 pouces). Sa queue conique offre une meilleure prise pour le tenir dans la machine. Sa pointe conventionnelle à 118° assure la résistance et facilite le réaffûtage. La finition avec traitement vapeur retient le liquide de coupe et empêche le collage des copeaux sur l'outil. Convient pour le perçage de nombreux matériaux.

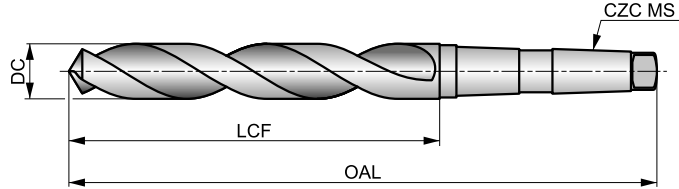

HSS	DIN 345	4xD
118°	ST	
λ 20-35°	R	DC h8

Adéquation du groupe de matériaux de la pièce, valeurs de départ pour la vitesse de coupe (m/min) et code Alpha d'avance. Les tableaux d'avances par tour se trouvent à partir de la page 274.

P1.1 ■ 33 I	P1.2 ■ 37 I	P1.3 ■ 38 I	P2.1 ■ 28 I	P2.2 ■ 25 F	P2.3 ■ 22 E	P3.1 ■ 18 F	P3.2 ■ 14 F	P3.3 ■ 12 E	P4.1 ■ 11 F	P4.2 ■ 9 E	P4.3 ■ 7 D	M1.1 ■ 21 E	M1.2 ■ 17 E
M2.1 ■ 18 E	M2.2 ■ 15 E	M3.1 ■ 10 G	M3.2 ■ 9 G	M3.3 ■ 8 G	M4.1 ■ 10 C	K1.1 ■ 30 I	K1.2 ■ 22 E	K1.3 ■ 17 E	K2.1 ■ 25 E	K2.2 ■ 20 E	K2.3 ■ 16 E	K3.1 ■ 22 E	K3.2 ■ 17 E
K3.3 ■ 13 E	K4.1 ■ 20 E	K4.2 ■ 15 E	K4.3 ■ 11 E	K4.4 ■ 10 E	K4.5 ■ 8 E	K5.1 ■ 23 E	K5.2 ■ 17 E	K5.3 ■ 13 E	N1.1 ■ 26 J	N1.2 ■ 20 J	N1.3 ■ 13 I	N2.1 ■ 43 H	N2.2 ■ 39 H
N2.3 ■ 28 H	N3.1 ■ 59 H	N3.2 ■ 35 I	N3.3 ■ 18 F	N4.1 ■ 30 K	N4.2 ■ 28 J	N4.3 ■ 14 H	S1.1 ■ 23 F	S1.2 ■ 13 D	S1.3 ■ 7 B	S2.1 ■ 9 E	S2.2 ■ 6 A	S3.1 ■ 7 E	S3.2 ■ 4 A
S4.1 ■ 5 E	S4.2 ■ 3 A												

DC > 14mm avec pointe amincie.

Product	DC	DC	DC	LCF	OAL	CZC MS
	(inch)	(mm)	(inch)			
A1303.0	–	3.00	0.1181	33.0	114.0	MK 1
A1301/8	1/8	3.18	0.1250	36.0	117.0	MK 1
A1303.3	–	3.30	0.1299	36.0	117.0	MK 1
A1303.5	–	3.50	0.1378	39.0	120.0	MK 1
A1304.0	–	4.00	0.1575	43.0	124.0	MK 1
A1304.2	–	4.20	0.1654	43.0	124.0	MK 1
A1304.25	–	4.25	0.1673	43.0	124.0	MK 1
A1304.5	–	4.50	0.1772	47.0	128.0	MK 1
A1303/16	3/16	4.76	0.1875	52.0	133.0	MK 1
A1305.0	–	5.00	0.1969	52.0	133.0	MK 1
A1305.1	–	5.10	0.2008	52.0	133.0	MK 1
A13013/64	13/64	5.16	0.2031	52.0	133.0	MK 1
A1305.2	–	5.20	0.2047	52.0	133.0	MK 1
A1305.5	–	5.50	0.2165	57.0	138.0	MK 1
A1306.0	–	6.00	0.2362	57.0	138.0	MK 1
A1301/4	1/4	6.35	0.2500	63.0	144.0	MK 1
A1306.5	–	6.50	0.2559	63.0	144.0	MK 1
A1306.7	–	6.70	0.2638	63.0	144.0	MK 1
A13017/64	17/64	6.75	0.2656	69.0	150.0	MK 1
A1306.75	–	6.75	0.2657	69.0	150.0	MK 1
A1306.8	–	6.80	0.2677	69.0	150.0	MK 1
A1307.0	–	7.00	0.2756	69.0	150.0	MK 1
A1309/32	9/32	7.14	0.2813	69.0	150.0	MK 1



Product	DC	DC	DC	LCF	OAL	CZC MS
	(inch)	(mm)	(inch)	(mm)	(mm)	
A1307.5	–	7.50	0.2953	69.0	150.0	MK 1
A1305/16	5/16	7.94	0.3125	75.0	156.0	MK 1
A1308.0	–	8.00	0.3150	75.0	156.0	MK 1
A1308.2	–	8.20	0.3228	75.0	156.0	MK 1
A1308.5	–	8.50	0.3346	75.0	156.0	MK 1
A1308.6	–	8.60	0.3386	81.0	162.0	MK 1
A1308.7	–	8.70	0.3425	81.0	162.0	MK 1
A13011/32	11/32	8.73	0.3438	81.0	162.0	MK 1
A1308.75	–	8.75	0.3445	81.0	162.0	MK 1
A1309.0	–	9.00	0.3543	81.0	162.0	MK 1
A1309.5	–	9.50	0.3740	81.0	162.0	MK 1
A1303/8	3/8	9.52	0.3750	87.0	168.0	MK 1
A13010.0	–	10.00	0.3937	87.0	168.0	MK 1
A13010.2	–	10.20	0.4016	87.0	168.0	MK 1
A13010.25	–	10.25	0.4035	87.0	168.0	MK 1
A13010.3	–	10.30	0.4055	87.0	168.0	MK 1
A13013/32	13/32	10.32	0.4063	87.0	168.0	MK 1
A13010.5	–	10.50	0.4134	87.0	168.0	MK 1
A13027/64	27/64	10.72	0.4219	94.0	175.0	MK 1
A13010.75	–	10.75	0.4232	94.0	175.0	MK 1
A13010.8	–	10.80	0.4252	94.0	175.0	MK 1
A13011.0	–	11.00	0.4331	94.0	175.0	MK 1
A1307/16	7/16	11.11	0.4375	94.0	175.0	MK 1
A13011.2	–	11.20	0.4409	94.0	175.0	MK 1
A13011.5	–	11.50	0.4528	94.0	175.0	MK 1
A13011.75	–	11.75	0.4626	94.0	175.0	MK 1
A13011.8	–	11.80	0.4646	94.0	175.0	MK 1
A13012.0	–	12.00	0.4724	101.0	182.0	MK 1
A13012.2	–	12.20	0.4803	101.0	182.0	MK 1
A13012.25	–	12.25	0.4823	101.0	182.0	MK 1
A13031/64	31/64	12.30	0.4844	101.0	182.0	MK 1
A13012.5	–	12.50	0.4921	101.0	182.0	MK 1
A13012.7	–	12.70	0.5000	101.0	182.0	MK 1
A1301/2	1/2	12.70	0.5000	101.0	182.0	MK 1
A13012.75	–	12.75	0.5020	101.0	182.0	MK 1
A13012.8	–	12.80	0.5039	101.0	182.0	MK 1
A13013.0	–	13.00	0.5118	101.0	182.0	MK 1
A13033/64	33/64	13.10	0.5156	101.0	182.0	MK 1
A13013.2	–	13.20	0.5197	101.0	182.0	MK 1
A13013.25	–	13.25	0.5217	108.0	189.0	MK 1
A13017/32	17/32	13.49	0.5313	108.0	189.0	MK 1
A13013.5	–	13.50	0.5315	108.0	189.0	MK 1
A13013.75	–	13.75	0.5413	108.0	189.0	MK 1
A13013.8	–	13.80	0.5433	108.0	189.0	MK 1
A13013.9	–	13.90	0.5472	108.0	189.0	MK 1
A13014.0	–	14.00	0.5512	108.0	189.0	MK 1
A13014.1	–	14.10	0.5551	114.0	212.0	MK 2
A13014.2	–	14.20	0.5591	114.0	212.0	MK 2
A13014.25	–	14.25	0.5610	114.0	212.0	MK 2
A1309/16	9/16	14.29	0.5625	114.0	212.0	MK 2
A13014.3	–	14.30	0.5630	114.0	212.0	MK 2
A13014.5	–	14.50	0.5709	114.0	212.0	MK 2
A13037/64	37/64	14.68	0.5781	114.0	212.0	MK 2
A13014.75	–	14.75	0.5807	114.0	212.0	MK 2
A13014.8	–	14.80	0.5827	114.0	212.0	MK 2
A13014.9	–	14.90	0.5866	114.0	212.0	MK 2
A13015.0	–	15.00	0.5906	114.0	212.0	MK 2
A13015.1	–	15.10	0.5945	120.0	218.0	MK 2
A13015.2	–	15.20	0.5984	120.0	218.0	MK 2
A13015.25	–	15.25	0.6004	120.0	218.0	MK 2
A13039/64	39/64	15.48	0.6094	120.0	218.0	MK 2
A13015.5	–	15.50	0.6102	120.0	218.0	MK 2

Product	DC	DC	DC	LCF	OAL	CZC MS
	(inch)	(mm)	(inch)	(mm)	(mm)	
A13015.7	–	15.70	0.6181	120.0	218.0	MK 2
A13015.75	–	15.75	0.6201	120.0	218.0	MK 2
A13015.8	–	15.80	0.6220	120.0	218.0	MK 2
A1305/8	5/8	15.88	0.6250	120.0	218.0	MK 2
A13015.9	–	15.90	0.6260	120.0	218.0	MK 2
A13016.0	–	16.00	0.6299	120.0	218.0	MK 2
A13016.1	–	16.10	0.6339	125.0	223.0	MK 2
A13016.2	–	16.20	0.6378	125.0	223.0	MK 2
A13016.25	–	16.25	0.6398	125.0	223.0	MK 2
A13041/64	41/64	16.27	0.6406	125.0	223.0	MK 2
A13016.5	–	16.50	0.6496	125.0	223.0	MK 2
A13021/32	21/32	16.67	0.6563	125.0	223.0	MK 2
A13016.75	–	16.75	0.6594	125.0	223.0	MK 2
A13017.0	–	17.00	0.6693	125.0	223.0	MK 2
A13043/64	43/64	17.07	0.6719	130.0	228.0	MK 2
A13017.25	–	17.25	0.6791	130.0	228.0	MK 2
A13011/16	11/16	17.46	0.6875	130.0	228.0	MK 2
A13017.5	–	17.50	0.6890	130.0	228.0	MK 2
A13017.75	–	17.75	0.6988	130.0	228.0	MK 2
A13045/64	45/64	17.86	0.7031	130.0	228.0	MK 2
A13018.0	–	18.00	0.7087	130.0	228.0	MK 2
A13018.25	–	18.25	0.7185	135.0	233.0	MK 2
A13023/32	23/32	18.26	0.7188	135.0	233.0	MK 2
A13018.5	–	18.50	0.7283	135.0	233.0	MK 2
A13047/64	47/64	18.65	0.7344	135.0	233.0	MK 2
A13018.75	–	18.75	0.7382	135.0	233.0	MK 2
A13019.0	–	19.00	0.7480	135.0	233.0	MK 2
A1303/4	3/4	19.05	0.7500	140.0	238.0	MK 2
A13019.25	–	19.25	0.7579	140.0	238.0	MK 2
A13019.5	–	19.50	0.7677	140.0	238.0	MK 2
A13019.75	–	19.75	0.7776	140.0	238.0	MK 2
A13025/32	25/32	19.84	0.7813	140.0	238.0	MK 2
A13020.0	–	20.00	0.7874	140.0	238.0	MK 2
A13020.25	–	20.25	0.7972	145.0	243.0	MK 2
A13020.5	–	20.50	0.8071	145.0	243.0	MK 2
A13013/16	13/16	20.64	0.8125	145.0	243.0	MK 2
A13020.75	–	20.75	0.8169	145.0	243.0	MK 2
A13021.0	–	21.00	0.8268	145.0	243.0	MK 2
A13021.25	–	21.25	0.8366	150.0	248.0	MK 2
A13021.5	–	21.50	0.8465	150.0	248.0	MK 2
A13021.75	–	21.75	0.8563	150.0	248.0	MK 2
A13022.0	–	22.00	0.8661	150.0	248.0	MK 2
A1307/8	7/8	22.22	0.8750	150.0	248.0	MK 2
A13022.25	–	22.25	0.8760	150.0	248.0	MK 2
A13022.5	–	22.50	0.8858	155.0	253.0	MK 2
A13057/64	57/64	22.62	0.8906	155.0	253.0	MK 2
A13022.75	–	22.75	0.8957	155.0	253.0	MK 2
A13023.0	–	23.00	0.9055	155.0	253.0	MK 2
A13029/32	29/32	23.02	0.9063	155.0	253.0	MK 2
A13023.25	–	23.25	0.9154	155.0	276.0	MK 3
A13023.5	–	23.50	0.9252	155.0	276.0	MK 3
A13023.75	–	23.75	0.9350	160.0	281.0	MK 3
A13015/16	15/16	23.81	0.9375	160.0	281.0	MK 3
A13024.0	–	24.00	0.9449	160.0	281.0	MK 3
A13061/64	61/64	24.21	0.9531	160.0	281.0	MK 3
A13024.5	–	24.50	0.9646	160.0	281.0	MK 3
A13024.75	–	24.75	0.9744	160.0	281.0	MK 3
A13025.0	–	25.00	0.9843	160.0	281.0	MK 3
A13025.25	–	25.25	0.9941	165.0	286.0	MK 3
A1301	1"	25.40	1.0000	165.0	286.0	MK 3
A13025.5	–	25.50	1.0039	165.0	286.0	MK 3
A13025.75	–	25.75	1.0138	165.0	286.0	MK 3



Product	DC	DC	DC	LCF	OAL	CZC MS
	(inch)	(mm)	(inch)	(mm)	(mm)	
A13026.0	–	26.00	1.0236	165.0	286.0	MK 3
A13026.25	–	26.25	1.0335	165.0	286.0	MK 3
A13026.5	–	26.50	1.0433	165.0	286.0	MK 3
A1301.1/16	1.1/16	26.99	1.0625	170.0	291.0	MK 3
A13027.0	–	27.00	1.0630	170.0	291.0	MK 3
A13027.5	–	27.50	1.0827	170.0	291.0	MK 3
A13028.0	–	28.00	1.1024	170.0	291.0	MK 3
A13028.5	–	28.50	1.1220	175.0	296.0	MK 3
A1301.1/8	1.1/8	28.58	1.1250	175.0	296.0	MK 3
A13029.0	–	29.00	1.1417	175.0	296.0	MK 3
A13029.5	–	29.50	1.1614	175.0	296.0	MK 3
A13030.0	–	30.00	1.1811	175.0	296.0	MK 3
A1301.3/16	1.3/16	30.16	1.1875	180.0	301.0	MK 3
A13030.5	–	30.50	1.2008	180.0	301.0	MK 3
A13031.0	–	31.00	1.2205	180.0	301.0	MK 3
A13031.5	–	31.50	1.2402	180.0	301.0	MK 3
A1301.1/4	1.1/4	31.75	1.2500	185.0	306.0	MK 3
A13032.0	–	32.00	1.2598	185.0	334.0	MK 4
A13032.5	–	32.50	1.2795	185.0	334.0	MK 4
A13033.0	–	33.00	1.2992	185.0	334.0	MK 4
A13033.5	–	33.50	1.3189	185.0	334.0	MK 4
A13034.0	–	34.00	1.3386	190.0	339.0	MK 4
A13034.5	–	34.50	1.3583	190.0	339.0	MK 4
A1301.3/8	1.3/8	34.93	1.3750	190.0	339.0	MK 4
A13035.0	–	35.00	1.3780	190.0	339.0	MK 4
A13035.5	–	35.50	1.3976	190.0	339.0	MK 4
A13036.0	–	36.00	1.4173	195.0	344.0	MK 4
A13037.0	–	37.00	1.4567	195.0	344.0	MK 4
A13037.5	–	37.50	1.4764	195.0	344.0	MK 4
A13038.0	–	38.00	1.4961	200.0	349.0	MK 4
A1301.1/2	1.1/2	38.10	1.5000	200.0	349.0	MK 4
A13038.5	–	38.50	1.5157	200.0	349.0	MK 4
A13039.0	–	39.00	1.5354	200.0	349.0	MK 4
A13039.5	–	39.50	1.5551	200.0	349.0	MK 4
A13040.0	–	40.00	1.5748	200.0	349.0	MK 4
A13041.0	–	41.00	1.6142	205.0	354.0	MK 4
A13042.0	–	42.00	1.6535	205.0	354.0	MK 4
A13043.0	–	43.00	1.6929	210.0	359.0	MK 4
A13044.0	–	44.00	1.7323	210.0	359.0	MK 4
A1301.3/4	1.3/4	44.45	1.7500	210.0	359.0	MK 4
A13045.0	–	45.00	1.7717	210.0	359.0	MK 4
A13046.0	–	46.00	1.8110	215.0	364.0	MK 4
A13048.0	–	48.00	1.8898	220.0	369.0	MK 4
A13049.0	–	49.00	1.9291	220.0	369.0	MK 4
A13050.0	–	50.00	1.9685	220.0	369.0	MK 4
A1302	2"	50.80	2.0000	225.0	374.0	MK 4

A002



Foret court en HSS, revêtement TiN en pointe

Foret polyvalent pour le perçage à la main et sur machines. Une pointe spéciale à 118° avec affûtage en croix aide à l'auto-centrage du foret lors du perçage à la main et fournit un trou de taille plus précise. Convient à de nombreux matériaux. Le revêtement TiN en pointe améliore les performances et prolonge la durée de vie de l'outil.

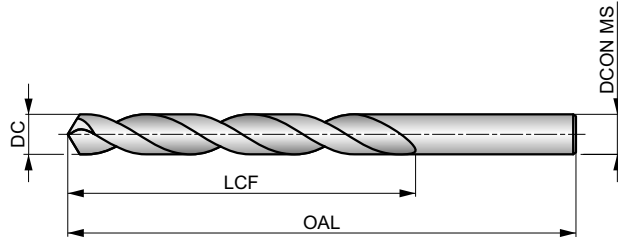

HSS	DIN 338	4×D
118°	TiN-Tip	
λ 20-35°	R	DC h8

Adéquation du groupe de matériaux de la pièce, valeurs de départ pour la vitesse de coupe (m/min) et code Alpha d'avance. Les tableaux d'avances par tour se trouvent à partir de la page 274.

P1.1 ■ 46 J	P1.2 ■ 52 J	P1.3 ■ 54 J	P2.1 ■ 40 J	P2.2 ■ 35 F	P2.3 ■ 31 F	P3.1 ■ 27 F	P3.2 ■ 21 F	P3.3 ■ 18 F	P4.1 ■ 16 F	P4.2 ■ 13 F	P4.3 ■ 11 E	M1.1 ■ 27 F	M1.2 ■ 23 F
M2.1 ■ 24 F	M2.2 ■ 20 F	M3.1 ■ 14 G	M3.2 ■ 12 G	M3.3 ■ 11 G	M4.1 ■ 16 C	K1.1 ■ 40 J	K1.2 ■ 30 E	K1.3 ■ 22 E	K2.1 ■ 34 E	K2.2 ■ 28 E	K2.3 ■ 22 E	K3.1 ■ 30 E	K3.2 ■ 23 E
K3.3 ■ 19 E	K4.1 ■ 28 E	K4.2 ■ 21 E	K4.3 ■ 16 E	K4.4 ■ 13 E	K4.5 ■ 11 E	K5.1 ■ 32 E	K5.2 ■ 24 E	K5.3 ■ 19 E	N1.1 ■ 41 K	N1.2 ■ 31 K	N1.3 ■ 21 J	N2.1 ■ 51 I	N2.2 ■ 46 I
N2.3 ■ 33 I	N3.1 ■ 56 H	N3.2 ■ 33 I	N3.3 ■ 17 G	N4.1 ■ 30 I	N4.2 ■ 50 H	N4.3 ■ 35 F	S1.1 ■ 23 F	S1.2 ■ 13 D	S1.3 ■ 7 B	S2.1 ■ 9 E	S2.2 ■ 4 A	S3.1 ■ 7 E	S3.2 ■ 3 A
S4.1 ■ 5 E	S4.2 ■ 2 A												

DC < 2mm Brillant; DC >= 2mm revêtu TiN en pointe avec affûtage en croix.
Les produits de cette série sont également disponibles en coffret. Voir A087, A089, A094, A095 ou A099.

Product	DC (inch)	DC (mm)	DC (inch)	LCF (mm)	OAL (mm)	DCON MS (mm)
A0021.0	—	1.00	0.0394	12.0	34.0	1.00
A0021.1	—	1.10	0.0433	14.0	36.0	1.10
A0023/64	3/64	1.19	0.0469	16.0	38.0	1.19
A0021.2	—	1.20	0.0472	16.0	38.0	1.20
A0021.3	—	1.30	0.0512	16.0	38.0	1.30
A0021.4	—	1.40	0.0551	18.0	40.0	1.40
A0021.5	—	1.50	0.0591	18.0	40.0	1.50
A0021/16	1/16	1.59	0.0625	20.0	43.0	1.59
A0021.6	—	1.60	0.0630	20.0	43.0	1.60
A0021.7	—	1.70	0.0669	20.0	43.0	1.70
A0021.8	—	1.80	0.0709	22.0	46.0	1.80
A0021.9	—	1.90	0.0748	22.0	46.0	1.90
A0025/64	5/64	1.98	0.0781	24.0	49.0	1.98
A0022.0	—	2.00	0.0787	24.0	49.0	2.00
A0022.1	—	2.10	0.0827	24.0	49.0	2.10
A0022.2	—	2.20	0.0866	27.0	53.0	2.20
A0022.3	—	2.30	0.0906	27.0	53.0	2.30
A0023/32	3/32	2.38	0.0938	30.0	57.0	2.38
A0022.4	—	2.40	0.0945	30.0	57.0	2.40
A0022.5	—	2.50	0.0984	30.0	57.0	2.50
A0022.6	—	2.60	0.1024	30.0	57.0	2.60
A0022.7	—	2.70	0.1063	33.0	61.0	2.70

Product	DC (inch)	DC (mm)	DC (inch)	LCF (mm)	OAL (mm)	DCON MS (mm)
A0027/64	7/64	2.78	0.1094	33.0	61.0	2.78
A0022.8	—	2.80	0.1102	33.0	61.0	2.80
A0022.9	—	2.90	0.1142	33.0	61.0	2.90
A0023.0	—	3.00	0.1181	33.0	61.0	3.00
A0023.1	—	3.10	0.1220	36.0	65.0	3.10
A0021/8	1/8	3.18	0.1250	36.0	65.0	3.18
A0023.2	—	3.20	0.1260	36.0	65.0	3.20
A0023.25	—	3.25	0.1280	36.0	65.0	3.25
A0023.3	—	3.30	0.1299	36.0	65.0	3.30
A0023.4	—	3.40	0.1339	39.0	70.0	3.40
A0023.5	—	3.50	0.1378	39.0	70.0	3.50
A0029/64	9/64	3.57	0.1406	39.0	70.0	3.57
A0023.6	—	3.60	0.1417	39.0	70.0	3.60
A0023.7	—	3.70	0.1457	39.0	70.0	3.70
A0023.8	—	3.80	0.1496	43.0	75.0	3.80
A0023.9	—	3.90	0.1535	43.0	75.0	3.90
A0025/32	5/32	3.97	0.1563	43.0	75.0	3.97
A0024.0	—	4.00	0.1575	43.0	75.0	4.00
A0024.1	—	4.10	0.1614	43.0	75.0	4.10
A0024.2	—	4.20	0.1654	43.0	75.0	4.20
A0024.3	—	4.30	0.1693	47.0	80.0	4.30
A00211/64	11/64	4.37	0.1719	47.0	80.0	4.37

Product	DC	DC	DC	LCF	OAL	DCON MS
	(inch)	(mm)	(inch)	(mm)	(mm)	(mm)
A0024.4	–	4.40	0.1732	47.0	80.0	4.40
A0024.5	–	4.50	0.1772	47.0	80.0	4.50
A0024.6	–	4.60	0.1811	47.0	80.0	4.60
A0024.7	–	4.70	0.1850	47.0	80.0	4.70
A0023/16	3/16	4.76	0.1875	52.0	86.0	4.76
A0024.8	–	4.80	0.1890	52.0	86.0	4.80
A0024.9	–	4.90	0.1929	52.0	86.0	4.90
A0025.0	–	5.00	0.1969	52.0	86.0	5.00
A0025.1	–	5.10	0.2008	52.0	86.0	5.10
A00213/64	13/64	5.16	0.2031	52.0	86.0	5.16
A0025.2	–	5.20	0.2047	52.0	86.0	5.20
A0025.3	–	5.30	0.2087	52.0	86.0	5.30
A0025.4	–	5.40	0.2126	57.0	93.0	5.40
A0025.5	–	5.50	0.2165	57.0	93.0	5.50
A0027/32	7/32	5.56	0.2188	57.0	93.0	5.56
A0025.6	–	5.60	0.2205	57.0	93.0	5.60
A0025.7	–	5.70	0.2244	57.0	93.0	5.70
A0025.8	–	5.80	0.2283	57.0	93.0	5.80
A0025.9	–	5.90	0.2323	57.0	93.0	5.90
A00215/64	15/64	5.95	0.2344	57.0	93.0	5.95
A0026.0	–	6.00	0.2362	57.0	93.0	6.00
A0026.1	–	6.10	0.2402	63.0	101.0	6.10
A0026.2	–	6.20	0.2441	63.0	101.0	6.20
A0026.3	–	6.30	0.2480	63.0	101.0	6.30
A0021/4	1/4	6.35	0.2500	63.0	101.0	6.35
A0026.4	–	6.40	0.2520	63.0	101.0	6.40
A0026.5	–	6.50	0.2559	63.0	101.0	6.50
A0026.6	–	6.60	0.2598	63.0	101.0	6.60
A0026.7	–	6.70	0.2638	63.0	101.0	6.70
A00217/64	17/64	6.75	0.2656	69.0	109.0	6.75
A0026.8	–	6.80	0.2677	69.0	109.0	6.80
A0026.9	–	6.90	0.2717	69.0	109.0	6.90
A0027.0	–	7.00	0.2756	69.0	109.0	7.00
A0027.1	–	7.10	0.2795	69.0	109.0	7.10
A0029/32	9/32	7.14	0.2813	69.0	109.0	7.14
A0027.2	–	7.20	0.2835	69.0	109.0	7.20
A0027.3	–	7.30	0.2874	69.0	109.0	7.30
A0027.4	–	7.40	0.2913	69.0	109.0	7.40
A0027.5	–	7.50	0.2953	69.0	109.0	7.50
A00219/64	19/64	7.54	0.2969	75.0	117.0	7.54
A0027.6	–	7.60	0.2992	75.0	117.0	7.60
A0027.7	–	7.70	0.3031	75.0	117.0	7.70
A0027.8	–	7.80	0.3071	75.0	117.0	7.80
A0027.9	–	7.90	0.3110	75.0	117.0	7.90
A0025/16	5/16	7.94	0.3125	75.0	117.0	7.94
A0028.0	–	8.00	0.3150	75.0	117.0	8.00
A0028.1	–	8.10	0.3189	75.0	117.0	8.10
A0028.2	–	8.20	0.3228	75.0	117.0	8.20
A0028.3	–	8.30	0.3268	75.0	117.0	8.30
A00221/64	21/64	8.33	0.3281	75.0	117.0	8.33
A0028.4	–	8.40	0.3307	75.0	117.0	8.40
A0028.5	–	8.50	0.3346	75.0	117.0	8.50
A0028.6	–	8.60	0.3386	81.0	125.0	8.60
A0028.7	–	8.70	0.3425	81.0	125.0	8.70
A00211/32	11/32	8.73	0.3438	81.0	125.0	8.73
A0028.8	–	8.80	0.3465	81.0	125.0	8.80
A0028.9	–	8.90	0.3504	81.0	125.0	8.90
A0029.0	–	9.00	0.3543	81.0	125.0	9.00
A0029.1	–	9.10	0.3583	81.0	125.0	9.10
A00223/64	23/64	9.13	0.3594	81.0	125.0	9.13
A0029.2	–	9.20	0.3622	81.0	125.0	9.20
A0029.3	–	9.30	0.3661	81.0	125.0	9.30
A0029.4	–	9.40	0.3701	81.0	125.0	9.40
A0029.5	–	9.50	0.3740	81.0	125.0	9.50
A0023/8	3/8	9.52	0.3750	87.0	133.0	9.52
A0029.6	–	9.60	0.3780	87.0	133.0	9.60
A0029.7	–	9.70	0.3819	87.0	133.0	9.70

Product	DC	DC	DC	LCF	OAL	DCON MS
	(inch)	(mm)	(inch)	(mm)	(mm)	(mm)
A0029.8	–	9.80	0.3858	87.0	133.0	9.80
A0029.9	–	9.90	0.3898	87.0	133.0	9.90
A00225/64	25/64	9.92	0.3906	87.0	133.0	9.92
A00210.0	–	10.00	0.3937	87.0	133.0	10.00
A00210.1	–	10.10	0.3976	87.0	133.0	10.10
A00210.2	–	10.20	0.4016	87.0	133.0	10.20
A00210.3	–	10.30	0.4055	87.0	133.0	10.30
A00213/32	13/32	10.32	0.4063	87.0	133.0	10.32
A00210.4	–	10.40	0.4094	87.0	133.0	10.40
A00210.5	–	10.50	0.4134	87.0	133.0	10.50
A00210.6	–	10.60	0.4173	87.0	133.0	10.60
A00210.7	–	10.70	0.4213	94.0	142.0	10.70
A00227/64	27/64	10.72	0.4219	94.0	142.0	10.72
A00210.8	–	10.80	0.4252	94.0	142.0	10.80
A00210.9	–	10.90	0.4291	94.0	142.0	10.90
A00211.0	–	11.00	0.4331	94.0	142.0	11.00
A00211.1	–	11.10	0.4370	94.0	142.0	11.10
A0027/16	7/16	11.11	0.4375	94.0	142.0	11.11
A00211.2	–	11.20	0.4409	94.0	142.0	11.20
A00211.3	–	11.30	0.4449	94.0	142.0	11.30
A00211.4	–	11.40	0.4488	94.0	142.0	11.40
A00211.5	–	11.50	0.4528	94.0	142.0	11.50
A00229/64	29/64	11.51	0.4531	94.0	142.0	11.51
A00211.6	–	11.60	0.4567	94.0	142.0	11.60
A00211.7	–	11.70	0.4606	94.0	142.0	11.70
A00211.8	–	11.80	0.4646	94.0	142.0	11.80
A00211.9	–	11.90	0.4685	101.0	151.0	11.90
A00215/32	15/32	11.91	0.4688	101.0	151.0	11.91
A00212.0	–	12.00	0.4724	101.0	151.0	12.00
A00212.1	–	12.10	0.4764	101.0	151.0	12.10
A00212.2	–	12.20	0.4803	101.0	151.0	12.20
A00212.3	–	12.30	0.4843	101.0	151.0	12.30
A00231/64	31/64	12.30	0.4844	101.0	151.0	12.30
A00212.4	–	12.40	0.4882	101.0	151.0	12.40
A00212.5	–	12.50	0.4921	101.0	151.0	12.50
A00212.6	–	12.60	0.4961	101.0	151.0	12.60
A00212.7	–	12.70	0.5000	101.0	151.0	12.70
A0021/2	1/2	12.70	0.5000	101.0	151.0	12.70
A00212.8	–	12.80	0.5039	101.0	151.0	12.80
A00212.9	–	12.90	0.5079	101.0	151.0	12.90
A00213.0	–	13.00	0.5118	101.0	151.0	13.00
A00233/64	33/64	13.10	0.5156	101.0	151.0	13.10
A00213.1	–	13.10	0.5157	101.0	151.0	13.10
A00213.2	–	13.20	0.5197	101.0	151.0	13.20
A00213.25	–	13.25	0.5217	108.0	160.0	13.25
A00213.3	–	13.30	0.5236	108.0	160.0	13.30
A00213.4	–	13.40	0.5276	108.0	160.0	13.40
A00217/32	17/32	13.49	0.5313	108.0	160.0	13.49
A00213.5	–	13.50	0.5315	108.0	160.0	13.50
A00213.6	–	13.60	0.5354	108.0	160.0	13.60
A00213.7	–	13.70	0.5394	108.0	160.0	13.70
A00213.75	–	13.75	0.5413	108.0	160.0	13.75
A00213.8	–	13.80	0.5433	108.0	160.0	13.80
A00213.9	–	13.90	0.5472	108.0	160.0	13.90
A00214.0	–	14.00	0.5512	108.0	160.0	14.00
A00214.25	–	14.25	0.5610	114.0	169.0	14.25
A0029/16	9/16	14.29	0.5625	114.0	169.0	14.29
A00214.5	–	14.50	0.5709	114.0	169.0	14.50
A00214.75	–	14.75	0.5807	114.0	169.0	14.75
A00215.0	–	15.00	0.5906	114.0	169.0	15.00
A00219/32	19/32	15.08	0.5938	120.0	178.0	15.08
A00215.25	–	15.25	0.6004	120.0	178.0	15.25
A00215.5	–	15.50	0.6102	120.0	178.0	15.50
A00215.75	–	15.75	0.6201	120.0	178.0	15.75
A0025/8	5/8	15.88	0.6250	120.0	178.0	15.88
A00216.0	–	16.00	0.6299	120.0	178.0	16.00

A002S



Foret court en HSS, revêtement TiN en pointe

Foret polyvalent pour le perçage à la main et sur machines, il est vendu à l'unité ou par 2 pièces (dia ≤ 5 mm). Une pointe spéciale à 118° avec affûtage en croix aide à l'auto-centrage du foret lors du perçage à la main et fournit un trou de taille plus précise. Convient à de nombreux matériaux. Le revêtement TiN en pointe améliore les performances et prolonge la durée de vie de l'outil.

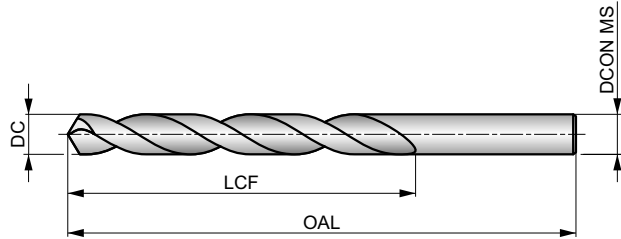

HSS	DIN 338	4×D
118°	TiN-Tip	
λ 20-35°	R	DC h8

Adéquation du groupe de matériaux de la pièce, valeurs de départ pour la vitesse de coupe (m/min) et code Alpha d'avance. Les tableaux d'avances par tour se trouvent à partir de la page 274.

P1.1 ■ 46 J	P1.2 ■ 52 J	P1.3 ■ 54 J	P2.1 ■ 40 J	P2.2 ■ 35 F	P2.3 ■ 31 F	P3.1 ■ 27 F	P3.2 ■ 21 F	P3.3 ■ 18 F	P4.1 ■ 16 F	P4.2 ■ 13 F	P4.3 ■ 11 E	M1.1 ■ 27 F	M1.2 ■ 23 F
M2.1 ■ 24 F	M2.2 ■ 20 F	M3.1 ■ 14 G	M3.2 ■ 12 G	M3.3 ■ 11 G	M4.1 ■ 16 C	K1.1 ■ 40 J	K1.2 ■ 30 E	K1.3 ■ 22 E	K2.1 ■ 34 E	K2.2 ■ 28 E	K2.3 ■ 22 E	K3.1 ■ 30 E	K3.2 ■ 23 E
K3.3 ■ 19 E	K4.1 ■ 28 E	K4.2 ■ 21 E	K4.3 ■ 16 E	K4.4 ■ 13 E	K4.5 ■ 11 E	K5.1 ■ 32 E	K5.2 ■ 24 E	K5.3 ■ 19 E	N1.1 ■ 41 K	N1.2 ■ 31 K	N1.3 ■ 21 J	N2.1 ■ 51 I	N2.2 ■ 46 I
N2.3 ■ 33 I	N3.1 ■ 56 H	N3.2 ■ 33 I	N3.3 ■ 17 G	N4.1 ■ 30 I	N4.2 ■ 50 H	N4.3 ■ 35 F	S1.1 ■ 23 F	S1.2 ■ 13 D	S1.3 ■ 7 B	S2.1 ■ 9 E	S2.2 ■ 4 A	S3.1 ■ 7 E	S3.2 ■ 3 A
S4.1 ■ 5 E	S4.2 ■ 2 A												

DC ≤ 5mm vendu par 2.

Product	DC (inch)	DC (mm)	DC (inch)	LCF (mm)	OAL (mm)	DCON MS (mm)
A002S2.0	–	2.00	0.0787	24.0	49.0	2.00
A002S2.5	–	2.50	0.0984	30.0	57.0	2.50
A002S3.0	–	3.00	0.1181	33.0	61.0	3.00
A002S1/8	1/8	3.18	0.1250	36.0	65.0	3.18
A002S3.2	–	3.20	0.1260	36.0	65.0	3.20
A002S3.3	–	3.30	0.1299	36.0	65.0	3.30
A002S3.5	–	3.50	0.1378	39.0	70.0	3.50
A002S5/32	5/32	3.97	0.1563	43.0	75.0	3.97
A002S4.0	–	4.00	0.1575	43.0	75.0	4.00
A002S4.1	–	4.10	0.1614	43.0	75.0	4.10
A002S4.2	–	4.20	0.1654	43.0	75.0	4.20
A002S4.5	–	4.50	0.1772	47.0	80.0	4.50
A002S3/16	3/16	4.76	0.1875	52.0	86.0	4.76
A002S5.0	–	5.00	0.1969	52.0	86.0	5.00
A002S13/64	13/64	5.16	0.2031	52.0	86.0	5.16
A002S5.5	–	5.50	0.2165	57.0	93.0	5.50
A002S7/32	7/32	5.56	0.2188	57.0	93.0	5.56
A002S6.0	–	6.00	0.2362	57.0	93.0	6.00
A002S1/4	1/4	6.35	0.2500	63.0	101.0	6.35
A002S6.5	–	6.50	0.2559	63.0	101.0	6.50

Product	DC (inch)	DC (mm)	DC (inch)	LCF (mm)	OAL (mm)	DCON MS (mm)
A002S6.8	–	6.80	0.2677	69.0	109.0	6.80
A002S7.0	–	7.00	0.2756	69.0	109.0	7.00
A002S7.5	–	7.50	0.2953	69.0	109.0	7.50
A002S5/16	5/16	7.94	0.3125	75.0	117.0	7.94
A002S8.0	–	8.00	0.3150	75.0	117.0	8.00
A002S8.2	–	8.20	0.3228	75.0	117.0	8.20
A002S8.5	–	8.50	0.3346	75.0	117.0	8.50
A002S9.0	–	9.00	0.3543	81.0	125.0	9.00
A002S9.5	–	9.50	0.3740	81.0	125.0	9.50
A002S3/8	3/8	9.52	0.3750	87.0	133.0	9.52
A002S10.0	–	10.00	0.3937	87.0	133.0	10.00
A002S10.2	–	10.20	0.4016	87.0	133.0	10.20
A002S10.5	–	10.50	0.4134	87.0	133.0	10.50
A002S11.0	–	11.00	0.4331	94.0	142.0	11.00
A002S11.5	–	11.50	0.4528	94.0	142.0	11.50
A002S12.0	–	12.00	0.4724	101.0	151.0	12.00
A002S12.5	–	12.50	0.4921	101.0	151.0	12.50
A002S1/2	1/2	12.70	0.5000	101.0	151.0	12.70
A002S13.0	–	13.00	0.5118	101.0	151.0	13.00

A108



Foret court en HSS, finition avec traitement vapeur (conçu pour l'acier inoxydable)

Foret premier choix pour le perçage de l'acier inoxydable avec des applications manuelles mais peut également être utilisé efficacement sur machines. Sa pointe à 135° avec affûtage en croix facilite l'auto-centrage et réduit les forces de coupe. La finition avec traitement vapeur aide à empêcher le matériau de la pièce de coller aux arêtes de coupe.

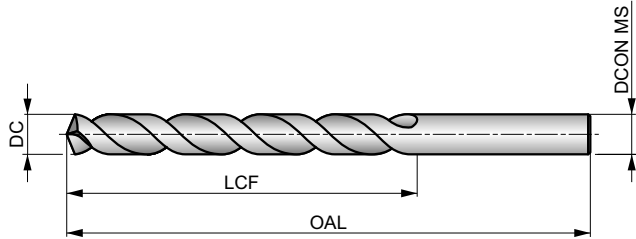

HSS	DIN 338	4×D
135°	ST	
λ>35°	R	DC h8

Adéquation du groupe de matériaux de la pièce, valeurs de départ pour la vitesse de coupe (m/min) et code Alpha d'avance. Les tableaux d'avances par tour se trouvent à partir de la page 274.

P1.1 ▣33 I	P1.2 ▣37 I	P1.3 ▣38 I	P2.1 ▣28 I	P2.2 ▣25 G	P2.3 ▣22 E	P3.1 ▣19 F	P3.2 ▣15 F	P3.3 ▣13 E	P4.1 ▣11 F	P4.2 ▣10 E	P4.3 ▣8 D	M1.1 ▣21 E	M1.2 ▣17 E
M2.1 ▣18 E	M2.2 ▣15 E	M3.1 ▣10 G	M3.2 ▣9 G	M3.3 ▣8 G	M4.1 ▣10 D	K1.1 ▣30 H	K1.2 ▣22 F	K1.3 ▣17 F	K2.1 ▣25 E	K2.2 ▣20 E	K2.3 ▣16 E	K3.1 ▣22 E	K3.2 ▣17 E
K3.3 ▣13 E	K4.1 ▣20 E	K4.2 ▣15 E	K4.3 ▣11 E	K4.4 ▣10 E	K4.5 ▣8 E	K5.1 ▣23 E	K5.2 ▣17 E	K5.3 ▣13 E	N1.1 ▣33 J	N1.2 ▣25 J	N1.3 ▣17 I	N2.1 ▣42 H	N2.2 ▣37 H
N2.3 ▣27 H	N3.1 ▣59 H	N3.2 ▣35 I	N3.3 ▣18 G	N4.1 ▣30 J	N4.2 ▣28 H	N4.3 ▣14 F	S1.1 ▣25 G	S1.2 ▣16 E	S1.3 ▣7 B	S2.1 ▣9 G	S2.2 ▣8 E	S3.1 ▣7 G	S3.2 ▣6 E
S4.1 ▣5 G	S4.2 ▣5 E												

DC > 1.5mm (1/16") avec affûtage en croix.
Les produits de cette série sont également disponibles en coffret.. Voir A188.

Product	DC (inch)	DC (mm)	DC (inch)	LCF (mm)	OAL (mm)	DCON MS (mm)
A1081.0	—	1.00	0.0394	12.0	34.0	1.00
A1081.1	—	1.10	0.0433	14.0	36.0	1.10
A1081.2	—	1.20	0.0472	16.0	38.0	1.20
A1081.3	—	1.30	0.0512	16.0	38.0	1.30
A1081.4	—	1.40	0.0551	18.0	40.0	1.40
A1081.5	—	1.50	0.0591	18.0	40.0	1.50
A1081/16	1/16	1.59	0.0625	20.0	43.0	1.59
A1081.6	—	1.60	0.0630	20.0	43.0	1.60
A1081.7	—	1.70	0.0669	20.0	43.0	1.70
A1081.8	—	1.80	0.0709	22.0	46.0	1.80
A1081.9	—	1.90	0.0748	22.0	46.0	1.90
A1085/64	5/64	1.98	0.0781	24.0	49.0	1.98
A1082.0	—	2.00	0.0787	24.0	49.0	2.00
A1082.1	—	2.10	0.0827	24.0	49.0	2.10
A1082.2	—	2.20	0.0866	27.0	53.0	2.20
A1082.3	—	2.30	0.0906	27.0	53.0	2.30
A1083/32	3/32	2.38	0.0938	30.0	57.0	2.38
A1082.4	—	2.40	0.0945	30.0	57.0	2.40
A1082.5	—	2.50	0.0984	30.0	57.0	2.50
A1082.6	—	2.60	0.1024	30.0	57.0	2.60
A1082.7	—	2.70	0.1063	33.0	61.0	2.70
A1087/64	7/64	2.78	0.1094	33.0	61.0	2.78

Product	DC (inch)	DC (mm)	DC (inch)	LCF (mm)	OAL (mm)	DCON MS (mm)
A1082.8	—	2.80	0.1102	33.0	61.0	2.80
A1082.9	—	2.90	0.1142	33.0	61.0	2.90
A1083.0	—	3.00	0.1181	33.0	61.0	3.00
A1083.1	—	3.10	0.1220	36.0	65.0	3.10
A1081/8	1/8	3.18	0.1250	36.0	65.0	3.18
A1083.2	—	3.20	0.1260	36.0	65.0	3.20
A1083.3	—	3.30	0.1299	36.0	65.0	3.30
A1083.4	—	3.40	0.1339	39.0	70.0	3.40
A1083.5	—	3.50	0.1378	39.0	70.0	3.50
A1089/64	9/64	3.57	0.1406	39.0	70.0	3.57
A1083.6	—	3.60	0.1417	39.0	70.0	3.60
A1083.7	—	3.70	0.1457	39.0	70.0	3.70
A1083.8	—	3.80	0.1496	43.0	75.0	3.80
A1083.9	—	3.90	0.1535	43.0	75.0	3.90
A1085/32	5/32	3.97	0.1563	43.0	75.0	3.97
A1084.0	—	4.00	0.1575	43.0	75.0	4.00
A1084.1	—	4.10	0.1614	43.0	75.0	4.10
A1084.2	—	4.20	0.1654	43.0	75.0	4.20
A1084.3	—	4.30	0.1693	47.0	80.0	4.30
A10811/64	11/64	4.37	0.1719	47.0	80.0	4.37
A1084.4	—	4.40	0.1732	47.0	80.0	4.40
A1084.5	—	4.50	0.1772	47.0	80.0	4.50

Product	DC	DC	DC	LCF	OAL	D CON MS
	(inch)	(mm)	(inch)	(mm)	(mm)	(mm)
A1084.6	–	4.60	0.1811	47.0	80.0	4.60
A1084.7	–	4.70	0.1850	47.0	80.0	4.70
A1083/16	3/16	4.76	0.1875	52.0	86.0	4.76
A1084.8	–	4.80	0.1890	52.0	86.0	4.80
A1084.9	–	4.90	0.1929	52.0	86.0	4.90
A108N10	N10	4.92	0.1935	52.0	86.0	4.92
A1085.0	–	5.00	0.1969	52.0	86.0	5.00
A1085.1	–	5.10	0.2008	52.0	86.0	5.10
A10813/64	13/64	5.16	0.2031	52.0	86.0	5.16
A1085.2	–	5.20	0.2047	52.0	86.0	5.20
A1085.3	–	5.30	0.2087	52.0	86.0	5.30
A1085.4	–	5.40	0.2126	57.0	93.0	5.40
A1085.5	–	5.50	0.2165	57.0	93.0	5.50
A1087/32	7/32	5.56	0.2188	57.0	93.0	5.56
A1085.6	–	5.60	0.2205	57.0	93.0	5.60
A1085.7	–	5.70	0.2244	57.0	93.0	5.70
A1085.8	–	5.80	0.2283	57.0	93.0	5.80
A1085.9	–	5.90	0.2323	57.0	93.0	5.90
A10815/64	15/64	5.95	0.2344	57.0	93.0	5.95
A1086.0	–	6.00	0.2362	57.0	93.0	6.00
A1086.1	–	6.10	0.2402	63.0	101.0	6.10
A1086.2	–	6.20	0.2441	63.0	101.0	6.20
A1086.3	–	6.30	0.2480	63.0	101.0	6.30
A1081/4	1/4	6.35	0.2500	63.0	101.0	6.35
A1086.4	–	6.40	0.2520	63.0	101.0	6.40
A1086.5	–	6.50	0.2559	63.0	101.0	6.50
A1086.6	–	6.60	0.2598	63.0	101.0	6.60
A1086.7	–	6.70	0.2638	63.0	101.0	6.70
A10817/64	17/64	6.75	0.2656	69.0	109.0	6.75
A1086.8	–	6.80	0.2677	69.0	109.0	6.80
A1086.9	–	6.90	0.2717	69.0	109.0	6.90
A1087.0	–	7.00	0.2756	69.0	109.0	7.00
A1087.1	–	7.10	0.2795	69.0	109.0	7.10
A1089/32	9/32	7.14	0.2813	69.0	109.0	7.14
A1087.2	–	7.20	0.2835	69.0	109.0	7.20
A1087.3	–	7.30	0.2874	69.0	109.0	7.30
A1087.4	–	7.40	0.2913	69.0	109.0	7.40
A1087.5	–	7.50	0.2953	69.0	109.0	7.50
A10819/64	19/64	7.54	0.2969	75.0	117.0	7.54
A1087.6	–	7.60	0.2992	75.0	117.0	7.60
A1087.7	–	7.70	0.3031	75.0	117.0	7.70
A1087.8	–	7.80	0.3071	75.0	117.0	7.80
A1087.9	–	7.90	0.3110	75.0	117.0	7.90
A1085/16	5/16	7.94	0.3125	75.0	117.0	7.94
A1088.0	–	8.00	0.3150	75.0	117.0	8.00
A1088.1	–	8.10	0.3189	75.0	117.0	8.10
A1088.2	–	8.20	0.3228	75.0	117.0	8.20

Product	DC	DC	DC	LCF	OAL	D CON MS
	(inch)	(mm)	(inch)	(mm)	(mm)	(mm)
A1088.3	–	8.30	0.3268	75.0	117.0	8.30
A10821/64	21/64	8.33	0.3281	75.0	117.0	8.33
A1088.4	–	8.40	0.3307	75.0	117.0	8.40
A1088.5	–	8.50	0.3346	75.0	117.0	8.50
A1088.6	–	8.60	0.3386	81.0	125.0	8.60
A1088.7	–	8.70	0.3425	81.0	125.0	8.70
A10811/32	11/32	8.73	0.3438	81.0	125.0	8.73
A1088.8	–	8.80	0.3465	81.0	125.0	8.80
A1088.9	–	8.90	0.3504	81.0	125.0	8.90
A1089.0	–	9.00	0.3543	81.0	125.0	9.00
A1089.1	–	9.10	0.3583	81.0	125.0	9.10
A10823/64	23/64	9.13	0.3594	81.0	125.0	9.13
A1089.2	–	9.20	0.3622	81.0	125.0	9.20
A1089.3	–	9.30	0.3661	81.0	125.0	9.30
A1089.4	–	9.40	0.3701	81.0	125.0	9.40
A1089.5	–	9.50	0.3740	81.0	125.0	9.50
A1083/8	3/8	9.52	0.3750	87.0	133.0	9.52
A1089.6	–	9.60	0.3780	87.0	133.0	9.60
A1089.7	–	9.70	0.3819	87.0	133.0	9.70
A1089.8	–	9.80	0.3858	87.0	133.0	9.80
A1089.9	–	9.90	0.3898	87.0	133.0	9.90
A10825/64	25/64	9.92	0.3906	87.0	133.0	9.92
A10810.0	–	10.00	0.3937	87.0	133.0	10.00
A10810.2	–	10.20	0.4016	87.0	133.0	10.20
A10813/32	13/32	10.32	0.4063	87.0	133.0	10.32
A10810.5	–	10.50	0.4134	87.0	133.0	10.50
A10827/64	27/64	10.72	0.4219	94.0	142.0	10.72
A10810.8	–	10.80	0.4252	94.0	142.0	10.80
A10811.0	–	11.00	0.4331	94.0	142.0	11.00
A1087/16	7/16	11.11	0.4375	94.0	142.0	11.11
A10811.5	–	11.50	0.4528	94.0	142.0	11.50
A10829/64	29/64	11.51	0.4531	94.0	142.0	11.51
A10811.8	–	11.80	0.4646	94.0	142.0	11.80
A10815/32	15/32	11.91	0.4688	101.0	151.0	11.91
A10812.0	–	12.00	0.4724	101.0	151.0	12.00
A10812.2	–	12.20	0.4803	101.0	151.0	12.20
A10831/64	31/64	12.30	0.4844	101.0	151.0	12.30
A10812.5	–	12.50	0.4921	101.0	151.0	12.50
A1081/2	1/2	12.70	0.5000	101.0	151.0	12.70
A10812.8	–	12.80	0.5039	101.0	151.0	12.80
A10813.0	–	13.00	0.5118	101.0	151.0	13.00
A10813.5	–	13.50	0.5315	108.0	160.0	13.50
A10814.0	–	14.00	0.5512	108.0	160.0	14.00
A10814.5	–	14.50	0.5709	114.0	169.0	14.50
A10815.0	–	15.00	0.5906	114.0	169.0	15.00
A10815.25	–	15.25	0.6004	120.0	178.0	15.25
A10816.0	–	16.00	0.6299	120.0	178.0	16.00

Code de matériau du corps (BMC)
 Groupe standard de base (BSG)
 Rapport longueur utile diamètre (ULDR)
 Angle d'application
 Revêtement
 Queue
 Forme de spirale
 Sens (direction de coupe)

HSS	HSS
DIN 340	BS 328
6×D	10×D



Code de famille de produits
 Plage de diamètres de coupe PSF

A110	A125
0.50 - 1"	1.40 - 3/4
36	38

	A110	A125
P	P1	■
	P2	■
	P3	☑
	P4	☑
M	M1	☑
	M2	☑
	M3	☑
	M4	☑
K	K1	☑
	K2	☑
	K3	☑
	K4	☑
	K5	☑
N	N1	☑
	N2	☑
	N3	☑
	N4	☑
	N5	☑
S	S1	☑
	S2	☑
	S3	☑
	S4	☑
H	H1	
	H2	
	H3	
	H4	

A110



Foret série longue en HSS, finition avec traitement vapeur

Foret pour perçage de trous plus profonds. Sa pointe conventionnelle à 118° offre de la résistance et est facile à réaffûter ce qui la rend très économique. Convient pour percer de nombreux matériaux. La finition avec traitement vapeur retient le fluide de coupe et empêche le collage des copeaux sur l'outil. Pour le perçage manuel et sur machines.

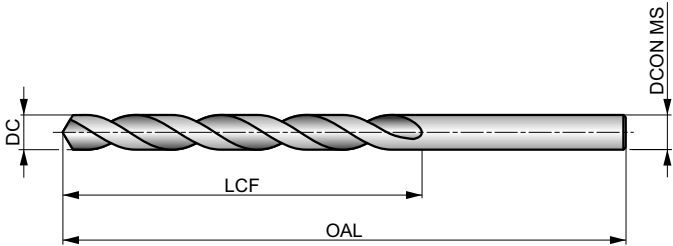

HSS	DIN 340	6×D
118°	ST	
λ 20-35°	R	DC h8

DC <= 1mm; 1/16° Brillant.

Product	DC (inch)	DC (mm)	DC (inch)	LCF (mm)	OAL (mm)	DCON MS (mm)
A110.5	–	0.50	0.0197	12.0	32.0	0.50
A110.6	–	0.60	0.0236	15.0	35.0	0.60
A110.7	–	0.70	0.0276	21.0	42.0	0.70
A1101/32	1/32	0.79	0.0313	25.0	46.0	0.79
A110.8	–	0.80	0.0315	25.0	46.0	0.80
A110.9	–	0.90	0.0354	29.0	51.0	0.90
A1101.0	–	1.00	0.0394	33.0	56.0	1.00
A1101.1	–	1.10	0.0433	37.0	60.0	1.10
A1101.2	–	1.20	0.0472	41.0	65.0	1.20
A1101.3	–	1.30	0.0512	41.0	65.0	1.30
A1101.4	–	1.40	0.0551	45.0	70.0	1.40
A1101.5	–	1.50	0.0591	45.0	70.0	1.50
A1101/16	1/16	1.59	0.0625	50.0	76.0	1.59
A1101.6	–	1.60	0.0630	50.0	76.0	1.60
A1101.7	–	1.70	0.0669	50.0	76.0	1.70
A1101.75	–	1.75	0.0689	53.0	80.0	1.75
A1101.8	–	1.80	0.0709	53.0	80.0	1.80
A1101.9	–	1.90	0.0748	53.0	80.0	1.90
A1105/64	5/64	1.98	0.0781	56.0	85.0	1.98
A1102.0	–	2.00	0.0787	56.0	85.0	2.00
A1102.05	–	2.05	0.0807	56.0	85.0	2.05
A1102.1	–	2.10	0.0827	56.0	85.0	2.10
A1102.2	–	2.20	0.0866	59.0	90.0	2.20
A1102.25	–	2.25	0.0886	59.0	90.0	2.25
A1102.3	–	2.30	0.0906	59.0	90.0	2.30
A1103/32	3/32	2.38	0.0938	62.0	95.0	2.38
A1102.4	–	2.40	0.0945	62.0	95.0	2.40
A1102.5	–	2.50	0.0984	62.0	95.0	2.50
A1102.6	–	2.60	0.1024	62.0	95.0	2.60
A1102.7	–	2.70	0.1063	66.0	100.0	2.70
A1107/64	7/64	2.78	0.1094	66.0	100.0	2.78
A1102.8	–	2.80	0.1102	66.0	100.0	2.80
A1102.9	–	2.90	0.1142	66.0	100.0	2.90

Product	DC (inch)	DC (mm)	DC (inch)	LCF (mm)	OAL (mm)	DCON MS (mm)
A1103.0	–	3.00	0.1181	66.0	100.0	3.00
A1103.1	–	3.10	0.1220	69.0	106.0	3.10
A1101/8	1/8	3.18	0.1250	69.0	106.0	3.18
A1103.2	–	3.20	0.1260	69.0	106.0	3.20
A1103.25	–	3.25	0.1280	69.0	106.0	3.25
A1103.3	–	3.30	0.1299	69.0	106.0	3.30
A1103.4	–	3.40	0.1339	73.0	112.0	3.40
A1103.5	–	3.50	0.1378	73.0	112.0	3.50
A1109/64	9/64	3.57	0.1406	73.0	112.0	3.57
A1103.6	–	3.60	0.1417	73.0	112.0	3.60
A1103.7	–	3.70	0.1457	73.0	112.0	3.70
A1103.75	–	3.75	0.1476	73.0	112.0	3.75
A1103.8	–	3.80	0.1496	78.0	119.0	3.80
A1103.9	–	3.90	0.1535	78.0	119.0	3.90
A1105/32	5/32	3.97	0.1563	78.0	119.0	3.97
A1104.0	–	4.00	0.1575	78.0	119.0	4.00
A1104.1	–	4.10	0.1614	78.0	119.0	4.10
A1104.2	–	4.20	0.1654	78.0	119.0	4.20
A1104.25	–	4.25	0.1673	78.0	119.0	4.25
A1104.3	–	4.30	0.1693	82.0	126.0	4.30
A11011/64	11/64	4.37	0.1719	82.0	126.0	4.37
A1104.4	–	4.40	0.1732	82.0	126.0	4.40
A1104.5	–	4.50	0.1772	82.0	126.0	4.50
A1104.6	–	4.60	0.1811	82.0	126.0	4.60
A1104.7	–	4.70	0.1850	82.0	126.0	4.70
A1104.75	–	4.75	0.1870	82.0	126.0	4.75
A1103/16	3/16	4.76	0.1875	87.0	132.0	4.76
A1104.8	–	4.80	0.1890	87.0	132.0	4.80
A1104.9	–	4.90	0.1929	87.0	132.0	4.90
A1105.0	–	5.00	0.1969	87.0	132.0	5.00
A1105.1	–	5.10	0.2008	87.0	132.0	5.10
A11013/64	13/64	5.16	0.2031	87.0	132.0	5.16
A1105.2	–	5.20	0.2047	87.0	132.0	5.20

Product	DC	DC	DC	LCF	OAL	D CON MS
	(inch)	(mm)	(inch)	(mm)	(mm)	(mm)
A1105.25	–	5.25	0.2067	87.0	132.0	5.25
A1105.3	–	5.30	0.2087	87.0	132.0	5.30
A1105.4	–	5.40	0.2126	91.0	139.0	5.40
A1105.5	–	5.50	0.2165	91.0	139.0	5.50
A1107/32	7/32	5.56	0.2188	91.0	139.0	5.56
A1105.6	–	5.60	0.2205	91.0	139.0	5.60
A1105.7	–	5.70	0.2244	91.0	139.0	5.70
A1105.75	–	5.75	0.2264	91.0	139.0	5.75
A1105.8	–	5.80	0.2283	91.0	139.0	5.80
A1105.9	–	5.90	0.2323	91.0	139.0	5.90
A11015/64	15/64	5.95	0.2344	91.0	139.0	5.95
A1106.0	–	6.00	0.2362	91.0	139.0	6.00
A1106.1	–	6.10	0.2402	97.0	148.0	6.10
A1106.2	–	6.20	0.2441	97.0	148.0	6.20
A1106.25	–	6.25	0.2461	97.0	148.0	6.25
A1106.3	–	6.30	0.2480	97.0	148.0	6.30
A1101/4	1/4	6.35	0.2500	97.0	148.0	6.35
A1106.4	–	6.40	0.2520	97.0	148.0	6.40
A1106.5	–	6.50	0.2559	97.0	148.0	6.50
A1106.6	–	6.60	0.2598	97.0	148.0	6.60
A1106.7	–	6.70	0.2638	97.0	148.0	6.70
A11017/64	17/64	6.75	0.2656	102.0	156.0	6.75
A1106.75	–	6.75	0.2657	102.0	156.0	6.75
A1106.8	–	6.80	0.2677	102.0	156.0	6.80
A1106.9	–	6.90	0.2717	102.0	156.0	6.90
A1107.0	–	7.00	0.2756	102.0	156.0	7.00
A1107.1	–	7.10	0.2795	102.0	156.0	7.10
A1109/32	9/32	7.14	0.2813	102.0	156.0	7.14
A1107.2	–	7.20	0.2835	102.0	156.0	7.20
A1107.25	–	7.25	0.2854	102.0	156.0	7.25
A1107.3	–	7.30	0.2874	102.0	156.0	7.30
A1107.4	–	7.40	0.2913	102.0	156.0	7.40
A1107.5	–	7.50	0.2953	102.0	156.0	7.50
A1107.6	–	7.60	0.2992	109.0	165.0	7.60
A1107.7	–	7.70	0.3031	109.0	165.0	7.70
A1107.75	–	7.75	0.3051	109.0	165.0	7.75
A1107.8	–	7.80	0.3071	109.0	165.0	7.80
A1107.9	–	7.90	0.3110	109.0	165.0	7.90
A1105/16	5/16	7.94	0.3125	109.0	165.0	7.94
A1108.0	–	8.00	0.3150	109.0	165.0	8.00
A1108.1	–	8.10	0.3189	109.0	165.0	8.10
A1108.2	–	8.20	0.3228	109.0	165.0	8.20
A1108.25	–	8.25	0.3248	109.0	165.0	8.25
A1108.3	–	8.30	0.3268	109.0	165.0	8.30
A1108.4	–	8.40	0.3307	109.0	165.0	8.40
A1108.5	–	8.50	0.3346	109.0	165.0	8.50
A1108.6	–	8.60	0.3386	115.0	175.0	8.60
A1108.7	–	8.70	0.3425	115.0	175.0	8.70
A11011/32	11/32	8.73	0.3438	115.0	175.0	8.73
A1108.75	–	8.75	0.3445	115.0	175.0	8.75
A1108.8	–	8.80	0.3465	115.0	175.0	8.80

Product	DC	DC	DC	LCF	OAL	D CON MS
	(inch)	(mm)	(inch)	(mm)	(mm)	(mm)
A1109.0	–	9.00	0.3543	115.0	175.0	9.00
A1109.1	–	9.10	0.3583	115.0	175.0	9.10
A1109.2	–	9.20	0.3622	115.0	175.0	9.20
A1109.3	–	9.30	0.3661	115.0	175.0	9.30
A1109.5	–	9.50	0.3740	115.0	175.0	9.50
A1103/8	3/8	9.52	0.3750	121.0	184.0	9.52
A1109.6	–	9.60	0.3780	121.0	184.0	9.60
A1109.7	–	9.70	0.3819	121.0	184.0	9.70
A1109.8	–	9.80	0.3858	121.0	184.0	9.80
A1109.9	–	9.90	0.3898	121.0	184.0	9.90
A11010.0	–	10.00	0.3937	121.0	184.0	10.00
A11010.1	–	10.10	0.3976	121.0	184.0	10.10
A11010.2	–	10.20	0.4016	121.0	184.0	10.20
A11010.25	–	10.25	0.4035	121.0	184.0	10.25
A11010.3	–	10.30	0.4055	121.0	184.0	10.30
A11013/32	13/32	10.32	0.4063	121.0	184.0	10.32
A11010.5	–	10.50	0.4134	121.0	184.0	10.50
A11010.75	–	10.75	0.4232	128.0	195.0	10.75
A11010.8	–	10.80	0.4252	128.0	195.0	10.80
A11011.0	–	11.00	0.4331	128.0	195.0	11.00
A1107/16	7/16	11.11	0.4375	128.0	195.0	11.11
A11011.5	–	11.50	0.4528	128.0	195.0	11.50
A11011.75	–	11.75	0.4626	128.0	195.0	11.75
A11012.0	–	12.00	0.4724	134.0	205.0	12.00
A11012.1	–	12.10	0.4764	134.0	205.0	12.10
A11012.25	–	12.25	0.4823	134.0	205.0	12.25
A11012.5	–	12.50	0.4921	134.0	205.0	12.50
A1101/2	1/2	12.70	0.5000	134.0	205.0	12.70
A11013.0	–	13.00	0.5118	134.0	205.0	13.00
A11017/32	17/32	13.49	0.5313	140.0	214.0	13.49
A11013.5	–	13.50	0.5315	140.0	214.0	13.50
A11014.0	–	14.00	0.5512	140.0	214.0	14.00
A1109/16	9/16	14.29	0.5625	144.0	220.0	14.29
A11014.5	–	14.50	0.5709	144.0	220.0	14.50
A11015.0	–	15.00	0.5906	144.0	220.0	15.00
A11015.5	–	15.50	0.6102	149.0	227.0	15.50
A1105/8	5/8	15.88	0.6250	149.0	227.0	15.88
A11016.0	–	16.00	0.6299	149.0	227.0	16.00
A11016.5	–	16.50	0.6496	154.0	235.0	16.50
A11017.0	–	17.00	0.6693	154.0	235.0	17.00
A11017.5	–	17.50	0.6890	158.0	241.0	17.50
A11018.0	–	18.00	0.7087	158.0	241.0	18.00
A11018.5	–	18.50	0.7283	162.0	247.0	18.50
A11019.0	–	19.00	0.7480	162.0	247.0	19.00
A1103/4	3/4	19.05	0.7500	166.0	254.0	19.05
A11019.5	–	19.50	0.7677	166.0	254.0	19.50
A11020.0	–	20.00	0.7874	166.0	254.0	20.00
A11021.0	–	21.00	0.8268	171.0	261.0	21.00
A11022.0	–	22.00	0.8661	176.0	268.0	22.00
A1107/8	7/8	22.22	0.8750	176.0	268.0	22.22
A1101	1"	25.40	1.0000	190.0	290.0	25.40

A125



Foret série extra-longue en HSS, finition avec traitement vapeur

Foret avec finition traitement vapeur recommandé pour les trous très profonds ou difficilement accessibles. Pointe conventionnelle à 118° offrant de la résistance et permettant d'économiser sur les affûtages simples. Convient à de nombreux matériaux. La finition avec traitement vapeur retient le liquide de coupe et empêche le collage des copeaux sur l'outil. Moins adapté au perçage à la main.

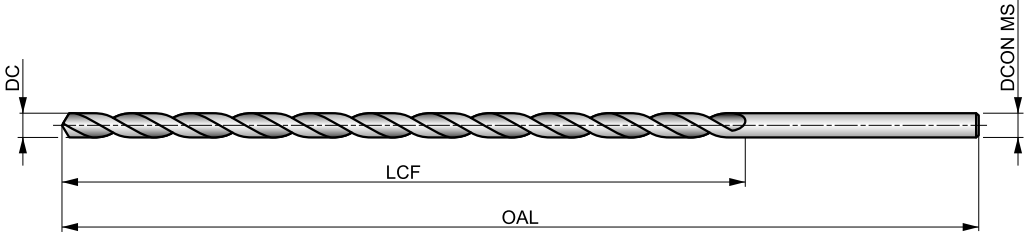

HSS	BS 328	10xD
118°	ST	
λ 20-35°	R	DC h8

DC <= 2.2mm; 5/64" Brillant.

Product	DC (inch)	DC (mm)	DC (inch)	LCF (mm)	OAL (mm)	DCON MS (mm)
A1251.4X160	—	1.40	0.0551	100.0	160.0	1.40
A1251.5X125	—	1.50	0.0591	80.0	125.0	1.50
A1251.5X160	—	1.50	0.0591	100.0	160.0	1.50
A1251/16X125	1/16	1.59	0.0625	80.0	125.0	1.59
A1251/16X160	1/16	1.59	0.0625	100.0	160.0	1.59
A1251.8X160	—	1.80	0.0709	100.0	160.0	1.80
A1255/64X125	5/64	1.98	0.0781	80.0	125.0	1.98
A1255/64X160	5/64	1.98	0.0781	100.0	160.0	1.98
A1252.0X125	—	2.00	0.0787	80.0	125.0	2.00
A1252.0X160	—	2.00	0.0787	100.0	160.0	2.00
A1252.2X160	—	2.20	0.0866	100.0	160.0	2.20
A1253/32X125	3/32	2.38	0.0938	80.0	125.0	2.38
A1253/32X160	3/32	2.38	0.0938	100.0	160.0	2.38
A1252.5X125	—	2.50	0.0984	80.0	125.0	2.50
A1252.5X160	—	2.50	0.0984	100.0	160.0	2.50
A1257/64X125	7/64	2.78	0.1094	80.0	125.0	2.78
A1257/64X160	7/64	2.78	0.1094	100.0	160.0	2.78
A1253.0X160	—	3.00	0.1181	100.0	160.0	3.00
A1253.0X200	—	3.00	0.1181	150.0	200.0	3.00
A1253.0X250	—	3.00	0.1181	200.0	250.0	3.00
A1251/8X160	1/8	3.18	0.1250	100.0	160.0	3.18
A1251/8X200	1/8	3.18	0.1250	150.0	200.0	3.18
A1251/8X250	1/8	3.18	0.1250	200.0	250.0	3.18
A1251/8X315	1/8	3.18	0.1250	250.0	310.0	3.18
A1253.3X160	—	3.30	0.1299	100.0	160.0	3.30
A1253.5X160	—	3.50	0.1378	100.0	160.0	3.50
A1253.5X200	—	3.50	0.1378	150.0	200.0	3.50
A1253.5X250	—	3.50	0.1378	200.0	250.0	3.50
A1259/64X160	9/64	3.57	0.1406	100.0	160.0	3.57
A1259/64X200	9/64	3.57	0.1406	150.0	200.0	3.57
A1259/64X315	9/64	3.57	0.1406	250.0	310.0	3.57
A1255/32X160	5/32	3.97	0.1563	100.0	160.0	3.97
A1255/32X200	5/32	3.97	0.1563	150.0	200.0	3.97

Product	DC (inch)	DC (mm)	DC (inch)	LCF (mm)	OAL (mm)	DCON MS (mm)
A1255/32X250	5/32	3.97	0.1563	200.0	250.0	3.97
A1255/32X315	5/32	3.97	0.1563	250.0	310.0	3.97
A1254.0X160	—	4.00	0.1575	100.0	160.0	4.00
A1254.0X200	—	4.00	0.1575	150.0	200.0	4.00
A1254.0X250	—	4.00	0.1575	200.0	250.0	4.00
A1254.0X315	—	4.00	0.1575	250.0	310.0	4.00
A12511/64X160	11/64	4.37	0.1719	100.0	160.0	4.37
A12511/64X200	11/64	4.37	0.1719	150.0	200.0	4.37
A12511/64X315	11/64	4.37	0.1719	250.0	310.0	4.37
A1254.5X160	—	4.50	0.1772	100.0	160.0	4.50
A1254.5X200	—	4.50	0.1772	150.0	200.0	4.50
A1254.5X250	—	4.50	0.1772	200.0	250.0	4.50
A1254.5X315	—	4.50	0.1772	250.0	310.0	4.50
A1253/16X160	3/16	4.76	0.1875	100.0	160.0	4.76
A1253/16X200	3/16	4.76	0.1875	150.0	200.0	4.76
A1253/16X250	3/16	4.76	0.1875	200.0	250.0	4.76
A1253/16X315	3/16	4.76	0.1875	250.0	310.0	4.76
A1253/16X400	3/16	4.76	0.1875	300.0	400.0	4.76
A1255.0X160	—	5.00	0.1969	100.0	160.0	5.00
A1255.0X200	—	5.00	0.1969	150.0	200.0	5.00
A1255.0X250	—	5.00	0.1969	200.0	250.0	5.00
A1255.0X315	—	5.00	0.1969	250.0	310.0	5.00
A1255.0X400	—	5.00	0.1969	300.0	400.0	5.00
A12513/64X200	13/64	5.16	0.2031	150.0	200.0	5.16
A12513/64X250	13/64	5.16	0.2031	200.0	250.0	5.16
A12513/64X315	13/64	5.16	0.2031	250.0	310.0	5.16
A1255.5X200	—	5.50	0.2165	150.0	200.0	5.50
A1255.5X250	—	5.50	0.2165	200.0	250.0	5.50
A1255.5X315	—	5.50	0.2165	250.0	310.0	5.50
A1257/32X200	7/32	5.56	0.2188	150.0	200.0	5.56
A1257/32X250	7/32	5.56	0.2188	200.0	250.0	5.56
A12515/64X200	15/64	5.95	0.2344	150.0	200.0	5.95
A12515/64X315	15/64	5.95	0.2344	250.0	310.0	5.95

Product	DC	DC	DC	LCF	OAL	DCON MS
	(inch)	(mm)	(inch)	(mm)	(mm)	(mm)
A1256.0X200	–	6.00	0.2362	150.0	200.0	6.00
A1256.0X250	–	6.00	0.2362	200.0	250.0	6.00
A1256.0X315	–	6.00	0.2362	250.0	310.0	6.00
A1256.0X400	–	6.00	0.2362	300.0	400.0	6.00
A1251/4X200	1/4	6.35	0.2500	150.0	200.0	6.35
A1251/4X250	1/4	6.35	0.2500	200.0	250.0	6.35
A1251/4X315	1/4	6.35	0.2500	250.0	310.0	6.35
A1251/4X400	1/4	6.35	0.2500	300.0	400.0	6.35
A1251/4X500	1/4	6.35	0.2500	400.0	460.0	6.35
A1256.5X200	–	6.50	0.2559	150.0	200.0	6.50
A1256.5X250	–	6.50	0.2559	200.0	250.0	6.50
A1256.5X315	–	6.50	0.2559	250.0	310.0	6.50
A12517/64X200	17/64	6.75	0.2656	150.0	200.0	6.75
A12517/64X250	17/64	6.75	0.2656	200.0	250.0	6.75
A12517/64X500	17/64	6.75	0.2656	400.0	460.0	6.75
A1257.0X200	–	7.00	0.2756	150.0	200.0	7.00
A1257.0X250	–	7.00	0.2756	200.0	250.0	7.00
A1257.0X315	–	7.00	0.2756	250.0	310.0	7.00
A1257.5X200	–	7.50	0.2953	150.0	200.0	7.50
A1257.5X250	–	7.50	0.2953	200.0	250.0	7.50
A1257.5X315	–	7.50	0.2953	250.0	310.0	7.50
A1255/16X200	5/16	7.94	0.3125	150.0	200.0	7.94
A1255/16X250	5/16	7.94	0.3125	200.0	250.0	7.94
A1255/16X315	5/16	7.94	0.3125	250.0	310.0	7.94
A1255/16X500	5/16	7.94	0.3125	400.0	460.0	7.94
A1258.0X250	–	8.00	0.3150	200.0	250.0	8.00
A1258.0X315	–	8.00	0.3150	250.0	310.0	8.00
A1258.0X400	–	8.00	0.3150	300.0	400.0	8.00
A12521/64X315	21/64	8.33	0.3281	250.0	310.0	8.33
A1258.5X250	–	8.50	0.3346	200.0	250.0	8.50
A1258.5X315	–	8.50	0.3346	250.0	310.0	8.50
A12511/32X250	11/32	8.73	0.3438	200.0	250.0	8.73
A12511/32X315	11/32	8.73	0.3438	250.0	310.0	8.73
A12511/32X400	11/32	8.73	0.3438	300.0	400.0	8.73
A12511/32X500	11/32	8.73	0.3438	400.0	460.0	8.73
A1259.0X250	–	9.00	0.3543	200.0	250.0	9.00
A1259.0X315	–	9.00	0.3543	250.0	310.0	9.00
A1259.0X400	–	9.00	0.3543	300.0	400.0	9.00
A1259.5X250	–	9.50	0.3740	200.0	250.0	9.50
A1259.5X315	–	9.50	0.3740	250.0	310.0	9.50

Product	DC	DC	DC	LCF	OAL	DCON MS
	(inch)	(mm)	(inch)	(mm)	(mm)	(mm)
A1253/8X250	3/8	9.52	0.3750	200.0	250.0	9.52
A1253/8X315	3/8	9.52	0.3750	250.0	310.0	9.52
A1253/8X400	3/8	9.52	0.3750	300.0	400.0	9.52
A1253/8X500	3/8	9.52	0.3750	400.0	460.0	9.52
A12510.0X250	–	10.00	0.3937	200.0	250.0	10.00
A12510.0X315	–	10.00	0.3937	250.0	310.0	10.00
A12510.0X400	–	10.00	0.3937	300.0	400.0	10.00
A12513/32X250	13/32	10.32	0.4063	200.0	250.0	10.32
A12513/32X315	13/32	10.32	0.4063	250.0	310.0	10.32
A12510.5X250	–	10.50	0.4134	200.0	250.0	10.50
A12510.5X315	–	10.50	0.4134	250.0	310.0	10.50
A12510.5X400	–	10.50	0.4134	300.0	400.0	10.50
A12511.0X250	–	11.00	0.4331	200.0	250.0	11.00
A12511.0X315	–	11.00	0.4331	250.0	310.0	11.00
A12511.0X400	–	11.00	0.4331	300.0	400.0	11.00
A1257/16X250	7/16	11.11	0.4375	200.0	250.0	11.11
A1257/16X315	7/16	11.11	0.4375	250.0	310.0	11.11
A1257/16X400	7/16	11.11	0.4375	300.0	400.0	11.11
A12529/64X315	29/64	11.51	0.4531	250.0	310.0	11.51
A12512.0X250	–	12.00	0.4724	200.0	250.0	12.00
A12512.0X315	–	12.00	0.4724	250.0	310.0	12.00
A12512.0X400	–	12.00	0.4724	300.0	400.0	12.00
A12531/64X315	31/64	12.30	0.4844	250.0	310.0	12.30
A1251/2X250	1/2	12.70	0.5000	200.0	250.0	12.70
A1251/2X315	1/2	12.70	0.5000	250.0	310.0	12.70
A1251/2X400	1/2	12.70	0.5000	300.0	400.0	12.70
A12513.0X315	–	13.00	0.5118	250.0	310.0	13.00
A12513.0X400	–	13.00	0.5118	300.0	400.0	13.00
A12517/32X315	17/32	13.49	0.5313	250.0	310.0	13.49
A12514.0X315	–	14.00	0.5512	250.0	310.0	14.00
A12514.0X400	–	14.00	0.5512	300.0	400.0	14.00
A1259/16X315	9/16	14.29	0.5625	250.0	310.0	14.29
A12537/64X315	37/64	14.68	0.5781	250.0	310.0	14.68
A12519/32X315	19/32	15.08	0.5938	250.0	310.0	15.08
A12519/32X500	19/32	15.08	0.5938	400.0	460.0	15.08
A1255/8X315	5/8	15.88	0.6250	250.0	310.0	15.88
A1255/8X500	5/8	15.88	0.6250	400.0	460.0	15.88
A12511/16X315	11/16	17.46	0.6875	250.0	310.0	17.46
A1253/4X315	3/4	19.05	0.7500	250.0	310.0	19.05
A1253/4X500	3/4	19.05	0.7500	400.0	460.0	19.05

Code de matériau du corps (BMC)		HSS	HSS	HSS	HSS	HSS	HSS-E	HSS-E	HSS-E	HSS-E	HSS-E		
Groupe standard de base (BSG)		NAS 907	NAS 907	NAS 907	NAS 907	NAS 907	NAS 907	NAS 907	NAS 907	NAS 907	NAS 907	DIN 338	
Rapport longueur utile diamètre (ULDR)		2.5xD	4xD	4xD	4xD	4xD	3xD	4xD	4xD	4xD	4xD	4xD	
Angle d'application													
Revêtement													
Queue													
Forme de spirale													
Sens (direction de coupe)													
		R40C R41C R42C	R10A R15A R18A	R10B R15B R18B	500-6 501-6 502-6	500-12 501-12 502-12	R88CO R89CO	R10CO R15CO R18CO	CO500-6 CO501-6	CO500-12 CO501-12	2ACO		
		N60 - 1/2	1/16 - 1/2	1/16 - 1/2	N60 - 1/2	3/64 - 1/2	1/16 - 1/2	N80 - 11/16	1/16 - 1/4	1/16 - 1/4	1.00 - 13.00		
P	P1	■	■	■	■	■	■	■	■	■	■		
	P2	■	■	■	■	■	■	■	■	■	■		
	P3	■	■	■	■	■	■	■	■	■	■		
	P4	■	■	■	■	■	■	■	■	■	■		
M	M1	■	■	■	■	■	■	■	■	■	■		
	M2	■	■	■	■	■	■	■	■	■	■		
	M3	■	■	■	■	■	■	■	■	■	■		
	M4	■	■	■	■	■	■	■	■	■	■		
K	K1	■	■	■	■	■	■	■	■	■	■		
	K2	■	■	■	■	■	■	■	■	■	■		
	K3	■	■	■	■	■	■	■	■	■	■		
	K4	■	■	■	■	■	■	■	■	■	■		
	K5	■	■	■	■	■	■	■	■	■	■		
N	N1	■	■	■	■	■	■	■	■	■	■		
	N2	■	■	■	■	■	■	■	■	■	■		
	N3	■	■	■	■	■	■	■	■	■	■		
	N4	■	■	■	■	■	■	■	■	■	■		
	N5	■	■	■	■	■	■	■	■	■	■		
S	S1	■	■	■	■	■	■	■	■	■	■		
	S2	■	■	■	■	■	■	■	■	■	■		
	S3	■	■	■	■	■	■	■	■	■	■		
	S4	■	■	■	■	■	■	■	■	■	■		
H	H1												
	H2												
	H3												
	H4												

R40C/R41C/R42C

PRECISION

Foret extra-court en HSS-E, type C NAS 907, avec traitement vapeur

Foret polyvalent avec traitement vapeur pour usage intensif. Sa pointe en croix à 135° autocentrante réduit les forces de coupe et empêche le foret de dévier lorsqu'il entre en contact avec la pièce à travailler. L'âme plus épaisse et la longueur réduite rendent ce foret très rigide et adapté au perçage manuel et mécanique de nombreux matériaux.

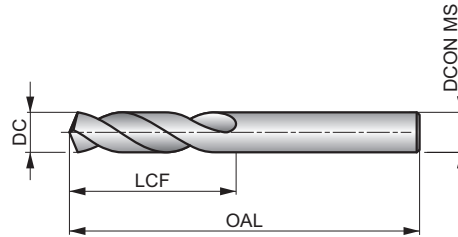

HSS	NAS 907	2.5xD
135°	ST	
λ 20-35°	R	

Adéquation du groupe de matériaux de la pièce, valeurs de départ pour la vitesse de coupe (m/min) et code Alpha d'avance. Les tableaux d'avances par tour se trouvent à partir de la page 274.

P1.1 ■ 36 J	P1.2 ■ 40 J	P1.3 ■ 41 J	P2.1 ■ 31 J	P2.2 ■ 27 G	P2.3 ■ 24 F	P3.1 ■ 21 G	P3.2 ■ 17 G	P3.3 ■ 14 F	P4.1 ■ 12 G	P4.2 ▣ 10 F	P4.3 ▣ 9 E	M1.1 ■ 22 F	M1.2 ■ 19 F
M2.1 ■ 20 F	M2.2 ■ 16 F	M3.1 ▣ 10 H	M3.2 ▣ 9 H	M3.3 ▣ 8 D	M4.1 ▣ 10 D	K1.1 ■ 32 J	K1.2 ■ 24 G	K1.3 ■ 18 G	K2.1 ■ 25 F	K2.2 ■ 20 F	K2.3 ■ 16 F	K3.1 ■ 22 F	K3.2 ■ 17 F
K3.3 ■ 13 F	K4.1 ■ 20 F	K4.2 ■ 15 F	K4.3 ▣ 11 F	K4.4 ▣ 10 F	K4.5 ▣ 8 F	K5.1 ■ 23 F	K5.2 ■ 17 F	K5.3 ▣ 13 F	N1.1 ▣ 33 K	N1.2 ▣ 25 K	N1.3 ▣ 17 J	N2.1 ▣ 46 I	N2.2 ▣ 42 I
N2.3 ▣ 30 I	N3.1 ▣ 64 I	N3.2 ▣ 38 J	N3.3 ▣ 19 H	N4.1 ▣ 30 K	N4.2 ▣ 35 I	N4.3 ▣ 17 G	S1.1 ■ 27 G	S1.2 ▣ 16 E	S1.3 ▣ 8 C	S2.1 ▣ 11 F	S2.2 ▣ 6 B	S3.1 ▣ 8 F	S3.2 ▣ 4 B
S4.1 ▣ 6 F	S4.2 ▣ 3 B												

Product	DC (inch)	DC (Wire gauge size)	DC (Letter size)	DC (inch)	LCF (inch)	OAL (inch)	DCON MS (inch)
R41CN60 ¹⁾	–	N60	–	0.0400	0.500	1.375	0.040
R41CN59 ¹⁾	–	N59	–	0.0410	0.500	1.375	0.041
R41CN58 ¹⁾	–	N58	–	0.0420	0.500	1.375	0.042
R41CN57 ¹⁾	–	N57	–	0.0430	0.500	1.375	0.043
R41CN56 ¹⁾	–	N56	–	0.0465	0.500	1.375	0.046
R41CN55 ¹⁾	–	N55	–	0.0520	0.625	1.625	0.052
R41CN54 ¹⁾	–	N54	–	0.0550	0.625	1.625	0.055
R41CN53 ¹⁾	–	N53	–	0.0595	0.625	1.625	0.059
R40C1/16	1/16	–	–	0.0625	0.625	1.625	0.063
R41CN52	–	N52	–	0.0635	0.688	1.688	0.064
R41CN51	–	N51	–	0.0670	0.688	1.688	0.067
R41CN50	–	N50	–	0.0700	0.688	1.688	0.070
R41CN49	–	N49	–	0.0730	0.688	1.688	0.073
R41CN48	–	N48	–	0.0760	0.688	1.688	0.076
R40C5/64	5/64	–	–	0.0781	0.688	1.688	0.078
R41CN47	–	N47	–	0.0785	0.688	1.688	0.079
R41CN46	–	N46	–	0.0810	0.750	1.750	0.081
R41CN45	–	N45	–	0.0820	0.750	1.750	0.082
R41CN44	–	N44	–	0.0860	0.750	1.750	0.086
R41CN43	–	N43	–	0.0890	0.750	1.750	0.089
R41CN42	–	N42	–	0.0935	0.750	1.750	0.093
R40C3/32	3/32	–	–	0.0938	0.750	1.750	0.094
R41CN41	–	N41	–	0.0960	0.813	1.813	0.096
R41CN40	–	N40	–	0.0980	0.813	1.813	0.098

Product	DC (inch)	DC (Wire gauge size)	DC (Letter size)	DC (inch)	LCF (inch)	OAL (inch)	DCON MS (inch)
R41CN39	–	N39	–	0.0995	0.813	1.813	0.100
R41CN38	–	N38	–	0.1015	0.813	1.813	0.102
R41CN37	–	N37	–	0.1040	0.813	1.813	0.104
R41CN36	–	N36	–	0.1065	0.813	1.813	0.106
R40C7/64	7/64	–	–	0.1094	0.813	1.813	0.109
R41CN35	–	N35	–	0.1100	0.875	1.875	0.110
R41CN34	–	N34	–	0.1110	0.875	1.875	0.111
R41CN33	–	N33	–	0.1130	0.875	1.875	0.113
R41CN32	–	N32	–	0.1160	0.875	1.875	0.116
R41CN31	–	N31	–	0.1200	0.875	1.875	0.120
R40C1/8	1/8	–	–	0.1250	0.875	1.875	0.125
R41CN30	–	N30	–	0.1285	0.938	1.938	0.129
R41CN29	–	N29	–	0.1360	0.938	1.938	0.136
R41CN28	–	N28	–	0.1405	0.938	1.938	0.141
R40C9/64	9/64	–	–	0.1406	0.938	1.938	0.141
R41CN27	–	N27	–	0.1440	1.000	2.063	0.144
R41CN26	–	N26	–	0.1470	1.000	2.063	0.147
R41CN25	–	N25	–	0.1495	1.000	2.063	0.149
R41CN24	–	N24	–	0.1520	1.000	2.063	0.152
R41CN23	–	N23	–	0.1540	1.000	2.063	0.154
R40C5/32	5/32	–	–	0.1563	1.000	2.063	0.156
R41CN22	–	N22	–	0.1570	1.063	2.125	0.157
R41CN21	–	N21	–	0.1590	1.063	2.125	0.159
R41CN20	–	N20	–	0.1610	1.063	2.125	0.161



Product	DC	DC	DC	DC	LCF	OAL	DCON MS
	(inch)	(Wire gauge size)	(Letter size)	(inch)	(inch)	(inch)	(inch)
R41CN19	–	N19	–	0.1660	1.063	2.125	0.166
R41CN18	–	N18	–	0.1695	1.063	2.125	0.170
R40C11/64	11/64	–	–	0.1719	1.063	2.125	0.172
R41CN17	–	N17	–	0.1730	1.125	2.188	0.173
R41CN16	–	N16	–	0.1770	1.125	2.188	0.177
R41CN15	–	N15	–	0.1800	1.125	2.188	0.180
R41CN14	–	N14	–	0.1820	1.125	2.188	0.182
R41CN13	–	N13	–	0.1850	1.125	2.188	0.185
R40C3/16	3/16	–	–	0.1875	1.125	2.188	0.188
R41CN12	–	N12	–	0.1890	1.188	2.250	0.189
R41CN11	–	N11	–	0.1910	1.188	2.250	0.191
R41CN10	–	N10	–	0.1935	1.188	2.250	0.194
R41CN9	–	N9	–	0.1960	1.188	2.250	0.196
R41CN8	–	N8	–	0.1990	1.188	2.250	0.199
R41CN7	–	N7	–	0.2010	1.188	2.250	0.201
R40C13/64	13/64	–	–	0.2031	1.188	2.250	0.203
R41CN6	–	N6	–	0.2040	1.250	2.375	0.204
R41CN5	–	N5	–	0.2055	1.250	2.375	0.205
R41CN4	–	N4	–	0.2090	1.250	2.375	0.209
R41CN3	–	N3	–	0.2130	1.250	2.375	0.213
R40C7/32	7/32	–	–	0.2188	1.250	2.375	0.219
R41CN2	–	N2	–	0.2210	1.313	2.438	0.221
R41CN1	–	N1	–	0.2280	1.313	2.438	0.228
R42CA	–	–	A	0.2340	1.313	2.438	0.234
R40C15/64	15/64	–	–	0.2344	1.313	2.438	0.234
R42CB	–	–	B	0.2380	1.375	2.500	0.238
R42CC	–	–	C	0.2420	1.375	2.500	0.242
R42CD	–	–	D	0.2460	1.375	2.500	0.246
R40C1/4	1/4	–	–	0.2500	1.375	2.500	0.250
R42CF	–	–	F	0.2570	1.438	2.625	0.257
R42CG	–	–	G	0.2610	1.438	2.625	0.261
R40C17/64	17/64	–	–	0.2656	1.438	2.625	0.266
R42CH	–	–	H	0.2660	1.500	2.688	0.266

¹⁾ Pas de pointe en croix.

Product	DC	DC	DC	DC	LCF	OAL	DCON MS
	(inch)	(Wire gauge size)	(Letter size)	(inch)	(inch)	(inch)	(inch)
R42CI	–	–	I	0.2720	1.500	2.688	0.272
R42CJ	–	–	J	0.2770	1.500	2.688	0.277
R42CK	–	–	K	0.2810	1.500	2.688	0.281
R40C9/32	9/32	–	–	0.2813	1.500	2.688	0.281
R42CM	–	–	M	0.2950	1.563	2.750	0.295
R40C19/64	19/64	–	–	0.2969	1.563	2.750	0.297
R42CL	–	–	L	0.2990	1.563	2.750	0.299
R42CN	–	–	N	0.3020	1.625	2.813	0.302
R40C5/16	5/16	–	–	0.3125	1.625	2.813	0.313
R42CO	–	–	O	0.3160	1.688	2.938	0.316
R42CP	–	–	P	0.3230	1.688	2.938	0.323
R40C21/64	21/64	–	–	0.3281	1.688	2.938	0.328
R42CQ	–	–	Q	0.3320	1.688	3.000	0.332
R42CR	–	–	R	0.3390	1.688	3.000	0.339
R40C11/32	11/32	–	–	0.3438	1.688	3.000	0.344
R42CS	–	–	S	0.3480	1.750	3.063	0.348
R42CT	–	–	T	0.3580	1.750	3.063	0.358
R40C23/64	23/64	–	–	0.3594	1.750	3.063	0.359
R42CU	–	–	U	0.3680	1.813	3.125	0.368
R40C3/8	3/8	–	–	0.3750	1.813	3.125	0.375
R42CV	–	–	V	0.3770	1.875	3.250	0.377
R42CW	–	–	W	0.3860	1.875	3.250	0.386
R40C25/64	25/64	–	–	0.3906	1.875	3.250	0.391
R42CX	–	–	X	0.3970	1.938	3.313	0.397
R42CY	–	–	Y	0.4040	1.938	3.313	0.404
R40C13/32	13/32	–	–	0.4063	1.938	3.313	0.406
R42CZ	–	–	Z	0.4130	2.000	3.375	0.413
R40C27/64	27/64	–	–	0.4219	2.000	3.375	0.422
R40C7/16	7/16	–	–	0.4375	2.063	3.438	0.438
R40C29/64	29/64	–	–	0.4531	2.125	3.563	0.453
R40C15/32	15/32	–	–	0.4688	2.125	3.625	0.469
R40C31/64	31/64	–	–	0.4844	2.188	3.688	0.484
R40C1/2	1/2	–	–	0.5000	2.250	3.750	0.500

R10A/R15A/R18A

PRECISION



Foret court en HSS, type A NAS 907, avec traitement vapeur

Un foret très performant avec une pointe en croix à 118° autocentrante pour une pénétration plus facile et une faible poussée. Traitement vapeur pour une meilleure résistance à l'usure et une meilleure lubrification. Fabriqué selon les normes aérospatiales NAS 907 Type A.

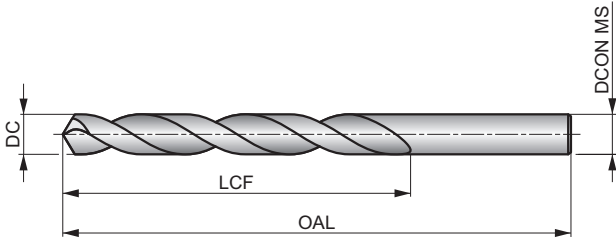

HSS	NAS 907	4xD
118°	ST	
λ 20-35°	R	

Adéquation du groupe de matériaux de la pièce, valeurs de départ pour la vitesse de coupe (m/min) et code Alpha d'avance. Les tableaux d'avances par tour se trouvent à partir de la page 274.

P1.1 ■ 36 H	P1.2 ■ 40 H	P1.3 ■ 41 H	P2.1 ■ 31 H	P2.2 ■ 27 G	P2.3 ■ 24 E	P3.1 ■ 25 F	P3.2 ■ 20 F	P3.3 ■ 17 E	P4.1 ■ 15 F	P4.2 ■ 13 E	P4.3 ■ 10 D	M1.1 ■ 30 E	M1.2 ■ 26 E
M2.1 ■ 27 E	M2.2 ■ 22 E	M2.3 ■ 18 C	M3.1 ■ 13 G	M3.2 ■ 11 G	M3.3 ■ 10 C	M4.1 ■ 15 C	M4.2 ■ 13 C	K1.1 ■ 35 H	K1.2 ■ 26 D	K1.3 ■ 19 D	K2.1 ■ 27 E	K2.2 ■ 22 E	K2.3 ■ 18 E
K3.1 ■ 24 E	K3.2 ■ 18 E	K3.3 ■ 15 E	K4.1 ■ 22 E	K4.2 ■ 17 E	K4.3 ■ 12 E	K4.4 ■ 11 E	K4.5 ■ 9 E	K5.1 ■ 25 E	K5.2 ■ 19 E	K5.3 ■ 15 E	N1.1 ■ 33 J	N1.2 ■ 25 J	N1.3 ■ 17 I
N2.1 ■ 46 H	N2.2 ■ 42 H	N2.3 ■ 30 H	N3.1 ■ 68 H	N3.2 ■ 40 F	N3.3 ■ 20 H	S1.1 ■ 28 F	S1.2 ■ 20 D	S1.3 ■ 11 C	S2.1 ■ 9 E	S2.2 ■ 8 B	S3.1 ■ 7 E	S3.2 ■ 6 B	S4.1 ■ 5 E
S4.2 ■ 5 B													

Product	DC (inch)	DC (Wire gauge size)	DC (Letter size)	DC (inch)	LCF (inch)	OAL (inch)	DCON MS (inch)
R10A1/16	1/16	-	-	0.0625	7/8	1.7/8	0.063
R18AN52	-	N52	-	0.0635	7/8	1.7/8	0.064
R18AN51	-	N51	-	0.0670	1"	2"	0.067
R18AN50	-	N50	-	0.0700	1"	2"	0.070
R18AN49	-	N49	-	0.0730	1"	2"	0.073
R18AN48	-	N48	-	0.0760	1"	2"	0.076
R10A5/64	5/64	-	-	0.0781	1"	2"	0.078
R18AN47	-	N47	-	0.0785	1"	2"	0.079
R18AN46	-	N46	-	0.0810	1.1/8	2.1/8	0.081
R18AN45	-	N45	-	0.0820	1.1/8	2.1/8	0.082
R18AN44	-	N44	-	0.0860	1.1/8	2.1/8	0.086
R18AN43	-	N43	-	0.0890	1.1/4	2.1/4	0.089
R18AN42	-	N42	-	0.0935	1.1/4	2.1/4	0.093
R10A3/32	3/32	-	-	0.0938	1.1/4	2.1/4	0.094
R18AN41	-	N41	-	0.0960	1.3/8	2.3/8	0.096
R18AN40	-	N40	-	0.0980	1.3/8	2.3/8	0.098
R18AN39	-	N39	-	0.0995	1.3/8	2.3/8	0.100
R18AN38	-	N38	-	0.1015	1.7/16	2.1/2	0.102
R18AN37	-	N37	-	0.1040	1.7/16	2.1/2	0.104
R18AN36	-	N36	-	0.1065	1.7/16	2.1/2	0.106
R10A7/64	7/64	-	-	0.1094	1.1/2	2.5/8	0.109
R18AN35	-	N35	-	0.1100	1.1/2	2.5/8	0.110
R18AN34	-	N34	-	0.1110	1.1/2	2.5/8	0.111
R18AN33	-	N33	-	0.1130	1.1/2	2.5/8	0.113

Product	DC (inch)	DC (Wire gauge size)	DC (Letter size)	DC (inch)	LCF (inch)	OAL (inch)	DCON MS (inch)
R18AN32	-	N32	-	0.1160	1.5/8	2.3/4	0.116
R18AN31	-	N31	-	0.1200	1.5/8	2.3/4	0.120
R10A1/8	1/8	-	-	0.1250	1.5/8	2.3/4	0.125
R18AN30	-	N30	-	0.1285	1.5/8	2.3/4	0.129
R18AN29	-	N29	-	0.1360	1.3/4	2.7/8	0.136
R18AN28	-	N28	-	0.1405	1.3/4	2.7/8	0.141
R10A9/64	9/64	-	-	0.1406	1.3/4	2.7/8	0.141
R18AN27	-	N27	-	0.1440	1.7/8	3"	0.144
R18AN26	-	N26	-	0.1470	1.7/8	3"	0.147
R18AN25	-	N25	-	0.1495	1.7/8	3"	0.149
R18AN24	-	N24	-	0.1520	2"	3.1/8	0.152
R18AN23	-	N23	-	0.1540	2"	3.1/8	0.154
R10A5/32	5/32	-	-	0.1563	2"	3.1/8	0.156
R18AN22	-	N22	-	0.1570	2"	3.1/8	0.157
R18AN21	-	N21	-	0.1590	2.1/8	3.1/4	0.159
R18AN20	-	N20	-	0.1610	2.1/8	3.1/4	0.161
R18AN19	-	N19	-	0.1660	2.1/8	3.1/4	0.166
R18AN18	-	N18	-	0.1695	2.1/8	3.1/4	0.170
R10A11/64	11/64	-	-	0.1719	2.1/8	3.1/4	0.172
R18AN17	-	N17	-	0.1730	2.3/16	3.3/8	0.173
R18AN16	-	N16	-	0.1770	2.3/16	3.3/8	0.177
R18AN15	-	N15	-	0.1800	2.3/16	3.3/8	0.180
R18AN14	-	N14	-	0.1820	2.3/16	3.3/8	0.182
R18AN13	-	N13	-	0.1850	2.5/16	3.1/2	0.185

Product	DC	DC	DC	DC	LCF	OAL	DCON MS
	(inch)	(Wire gauge size)	(Letter size)	(inch)	(inch)	(inch)	(inch)
R10A3/16	3/16	–	–	0.1875	2.5/16	3.1/2	0.188
R18AN12	–	N12	–	0.1890	2.5/16	3.1/2	0.189
R18AN11	–	N11	–	0.1910	2.5/16	3.1/2	0.191
R18AN10	–	N10	–	0.1935	2.7/16	3.5/8	0.194
R18AN9	–	N9	–	0.1960	2.7/16	3.5/8	0.196
R18AN8	–	N8	–	0.1990	2.7/16	3.5/8	0.199
R18AN7	–	N7	–	0.2010	2.7/16	3.5/8	0.201
R10A13/64	13/64	–	–	0.2031	2.7/16	3.5/8	0.203
R18AN6	–	N6	–	0.2040	2.1/2	3.3/4	0.204
R18AN5	–	N5	–	0.2055	2.1/2	3.3/4	0.205
R18AN4	–	N4	–	0.2090	2.1/2	3.3/4	0.209
R18AN3	–	N3	–	0.2130	2.1/2	3.3/4	0.213
R10A7/32	7/32	–	–	0.2188	2.1/2	3.3/4	0.219
R18AN2	–	N2	–	0.2210	2.5/8	3.7/8	0.221
R18AN1	–	N1	–	0.2280	2.5/8	3.7/8	0.228
R15AA	–	–	A	0.2340	2.5/8	3.7/8	0.234
R10A15/64	15/64	–	–	0.2344	2.5/8	3.7/8	0.234
R15AB	–	–	B	0.2380	2.3/4	4"	0.238
R15AC	–	–	C	0.2420	2.3/4	4"	0.242
R15AD	–	–	D	0.2460	2.3/4	4"	0.246
R10A1/4	1/4	–	–	0.2500	2.3/4	4"	0.250
R15AF	–	–	F	0.2570	2.7/8	4.1/8	0.257
R15AG	–	–	G	0.2610	2.7/8	4.1/8	0.261
R10A17/64	17/64	–	–	0.2656	2.7/8	4.1/8	0.266
R15AH	–	–	H	0.2660	2.7/8	4.1/8	0.266
R15AI	–	–	I	0.2720	2.7/8	4.1/8	0.272
R15AJ	–	–	J	0.2770	2.7/8	4.1/8	0.277
R15AK	–	–	K	0.2810	2.15/16	4.1/4	0.281
R10A9/32	9/32	–	–	0.2813	2.15/16	4.1/4	0.281

Product	DC	DC	DC	DC	LCF	OAL	DCON MS
	(inch)	(Wire gauge size)	(Letter size)	(inch)	(inch)	(inch)	(inch)
R15AL	–	–	L	0.2900	2.15/16	4.1/4	0.290
R15AM	–	–	M	0.2950	3.1/16	4.3/8	0.295
R10A19/64	19/64	–	–	0.2969	3.1/16	4.3/8	0.297
R15AN	–	–	N	0.3020	3.1/16	4.3/8	0.302
R10A5/16	5/16	–	–	0.3125	3.3/16	4.1/2	0.313
R15AO	–	–	O	0.3160	3.3/16	4.1/2	0.316
R15AP	–	–	P	0.3230	3.5/16	4.5/8	0.323
R10A21/64	21/64	–	–	0.3281	3.5/16	4.5/8	0.328
R15AQ	–	–	Q	0.3320	3.7/16	4.3/4	0.332
R15AR	–	–	R	0.3390	3.7/16	4.3/4	0.339
R10A11/32	11/32	–	–	0.3438	3.7/16	4.3/4	0.344
R15AS	–	–	S	0.3480	3.1/2	4.7/8	0.348
R15AT	–	–	T	0.3580	3.1/2	4.7/8	0.358
R10A23/64	23/64	–	–	0.3594	3.1/2	4.7/8	0.359
R15AU	–	–	U	0.3680	3.5/8	5"	0.368
R10A3/8	3/8	–	–	0.3750	3.5/8	5"	0.375
R15AV	–	–	V	0.3770	3.5/8	5"	0.377
R15AW	–	–	W	0.3860	3.3/4	5.1/8	0.386
R10A25/64	25/64	–	–	0.3906	3.3/4	5.1/8	0.391
R15AX	–	–	X	0.3970	3.3/4	5.1/8	0.397
R15AY	–	–	Y	0.4040	3.7/8	5.1/4	0.404
R10A13/32	13/32	–	–	0.4063	3.7/8	5.1/4	0.406
R15AZ	–	–	Z	0.4130	3.7/8	5.1/4	0.413
R10A27/64	27/64	–	–	0.4219	3.15/16	5.3/8	0.422
R10A7/16	7/16	–	–	0.4375	4.1/16	5.1/2	0.438
R10A29/64	29/64	–	–	0.4531	4.3/16	5.5/8	0.453
R10A15/32	15/32	–	–	0.4688	4.5/16	5.3/4	0.469
R10A31/64	31/64	–	–	0.4844	4.3/8	5.7/8	0.484
R10A1/2	1/2	–	–	0.5000	4.1/2	6"	0.500

R10B/R15B/R18B

PRECISION



Foret court en HSS, type B NAS 907, avec traitement vapeur

Foret court pour usage intensif avec une pointe en croix à 135° autocentrante et à faible poussée pour une pénétration plus facile. Traitement vapeur pour une meilleure résistance à l'usure et une meilleure lubrification. Fabriqué selon les normes aérospatiales NAS 907 Type B.

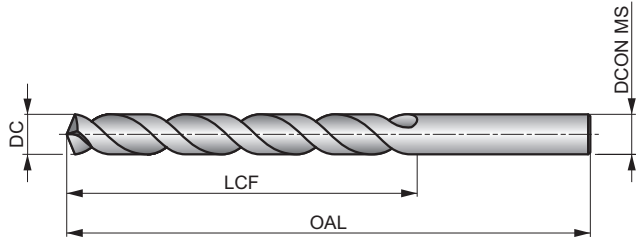

HSS	NAS 907	4xD
135°	ST	
λ 20-35°	R	

Adéquation du groupe de matériaux de la pièce, valeurs de départ pour la vitesse de coupe (m/min) et code Alpha d'avance. Les tableaux d'avances par tour se trouvent à partir de la page 274.

P1.1 36 H	P1.2 40 H	P1.3 41 H	P2.1 31 H	P2.2 27 G	P2.3 24 E	P3.1 25 F	P3.2 20 F	P3.3 17 E	P4.1 15 F	P4.2 13 E	P4.3 10 D	M1.1 30 E	M1.2 26 E
M2.1 27 E	M2.2 22 E	M2.3 18 C	M3.1 13 G	M3.2 11 G	M3.3 10 C	M4.1 15 C	M4.2 13 C	K1.1 35 H	K1.2 26 D	K1.3 19 D	K2.1 27 E	K2.2 22 E	K2.3 18 E
K3.1 24 E	K3.2 18 E	K3.3 15 E	K4.1 22 E	K4.2 17 E	K4.3 12 E	K4.4 11 E	K4.5 9 E	K5.1 25 E	K5.2 19 E	K5.3 15 E	N1.1 33 J	N1.2 25 J	N1.3 17 I
N2.1 46 H	N2.2 42 H	N2.3 30 H	N3.1 68 H	N3.2 40 F	N3.3 20 H	S1.1 28 F	S1.2 20 D	S1.3 11 C	S2.1 9 E	S2.2 8 B	S3.1 7 E	S3.2 6 B	S4.1 5 E
S4.2 5 B													

Product	DC (inch)	DC (Wire gauge size)	DC (Letter size)	DC (inch)	LCF (inch)	OAL (inch)	DCON MS (inch)
R10B1/16	1/16	-	-	0.0625	7/8	1.7/8	0.063
R18BN52	-	N52	-	0.0635	7/8	1.7/8	0.064
R18BN51	-	N51	-	0.0670	1"	2"	0.067
R18BN50	-	N50	-	0.0700	1"	2"	0.070
R18BN49	-	N49	-	0.0730	1"	2"	0.073
R18BN48	-	N48	-	0.0760	1"	2"	0.076
R10B5/64	5/64	-	-	0.0781	1"	2"	0.078
R18BN47	-	N47	-	0.0785	1"	2"	0.079
R18BN46	-	N46	-	0.0810	1.1/8	2.1/8	0.081
R18BN45	-	N45	-	0.0820	1.1/8	2.1/8	0.082
R18BN44	-	N44	-	0.0860	1.1/8	2.1/8	0.086
R18BN43	-	N43	-	0.0890	1.1/4	2.1/4	0.089
R18BN42	-	N42	-	0.0935	1.1/4	2.1/4	0.093
R10B3/32	3/32	-	-	0.0938	1.1/4	2.1/4	0.094
R18BN41	-	N41	-	0.0960	1.3/8	2.3/8	0.096
R18BN40	-	N40	-	0.0980	1.3/8	2.3/8	0.098
R18BN39	-	N39	-	0.0995	1.3/8	2.3/8	0.100
R18BN38	-	N38	-	0.1015	1.7/16	2.1/2	0.102
R18BN37	-	N37	-	0.1040	1.7/16	2.1/2	0.104
R18BN36	-	N36	-	0.1065	1.7/16	2.1/2	0.106
R10B7/64	7/64	-	-	0.1094	1.1/2	2.5/8	0.109
R18BN35	-	N35	-	0.1100	1.1/2	2.5/8	0.110
R18BN34	-	N34	-	0.1110	1.1/2	2.5/8	0.111
R18BN33	-	N33	-	0.1130	1.1/2	2.5/8	0.113

Product	DC (inch)	DC (Wire gauge size)	DC (Letter size)	DC (inch)	LCF (inch)	OAL (inch)	DCON MS (inch)
R18BN32	-	N32	-	0.1160	1.5/8	2.3/4	0.116
R18BN31	-	N31	-	0.1200	1.5/8	2.3/4	0.120
R10B1/8	1/8	-	-	0.1250	1.5/8	2.3/4	0.125
R18BN30	-	N30	-	0.1285	1.5/8	2.3/4	0.129
R18BN29	-	N29	-	0.1360	1.3/4	2.7/8	0.136
R18BN28	-	N28	-	0.1405	1.3/4	2.7/8	0.141
R10B9/64	9/64	-	-	0.1406	1.3/4	2.7/8	0.141
R18BN27	-	N27	-	0.1440	1.7/8	3"	0.144
R18BN26	-	N26	-	0.1470	1.7/8	3"	0.147
R18BN25	-	N25	-	0.1495	1.7/8	3"	0.149
R18BN24	-	N24	-	0.1520	2"	3.1/8	0.152
R18BN23	-	N23	-	0.1540	2"	3.1/8	0.154
R10B5/32	5/32	-	-	0.1563	2"	3.1/8	0.156
R18BN22	-	N22	-	0.1570	2"	3.1/8	0.157
R18BN21	-	N21	-	0.1590	2.1/8	3.1/4	0.159
R18BN20	-	N20	-	0.1610	2.1/8	3.1/4	0.161
R18BN19	-	N19	-	0.1660	2.1/8	3.1/4	0.166
R18BN18	-	N18	-	0.1695	2.1/8	3.1/4	0.170
R10B11/64	11/64	-	-	0.1719	2.1/8	3.1/4	0.172
R18BN17	-	N17	-	0.1730	2.3/16	3.3/8	0.173
R18BN16	-	N16	-	0.1770	2.3/16	3.3/8	0.177
R18BN15	-	N15	-	0.1800	2.3/16	3.3/8	0.180
R18BN14	-	N14	-	0.1820	2.3/16	3.3/8	0.182
R18BN13	-	N13	-	0.1850	2.5/16	3.1/2	0.185

Product	DC	DC	DC	DC	LCF	OAL	DCON MS
	(inch)	(Wire gauge size)	(Letter size)	(inch)	(inch)	(inch)	(inch)
R10B3/16	3/16	–	–	0.1875	2.5/16	3.1/2	0.188
R18BN12	–	N12	–	0.1890	2.5/16	3.1/2	0.189
R18BN11	–	N11	–	0.1910	2.5/16	3.1/2	0.191
R18BN10	–	N10	–	0.1935	2.7/16	3.5/8	0.194
R18BN9	–	N9	–	0.1960	2.7/16	3.5/8	0.196
R18BN8	–	N8	–	0.1990	2.7/16	3.5/8	0.199
R18BN7	–	N7	–	0.2010	2.7/16	3.5/8	0.201
R10B13/64	13/64	–	–	0.2031	2.7/16	3.5/8	0.203
R18BN6	–	N6	–	0.2040	2.1/2	3.3/4	0.204
R18BN5	–	N5	–	0.2055	2.1/2	3.3/4	0.205
R18BN4	–	N4	–	0.2090	2.1/2	3.3/4	0.209
R18BN3	–	N3	–	0.2130	2.1/2	3.3/4	0.213
R10B7/32	7/32	–	–	0.2188	2.1/2	3.3/4	0.219
R18BN2	–	N2	–	0.2210	2.5/8	3.7/8	0.221
R18BN1	–	N1	–	0.2280	2.5/8	3.7/8	0.228
R15BA	–	–	A	0.2340	2.5/8	3.7/8	0.234
R10B15/64	15/64	–	–	0.2344	2.5/8	3.7/8	0.234
R15BB	–	–	B	0.2380	2.3/4	4"	0.238
R15BC	–	–	C	0.2420	2.3/4	4"	0.242
R15BD	–	–	D	0.2460	2.3/4	4"	0.246
R10B1/4	1/4	–	–	0.2500	2.3/4	4"	0.250
R15BF	–	–	F	0.2570	2.7/8	4.1/8	0.257
R15BG	–	–	G	0.2610	2.7/8	4.1/8	0.261
R10B17/64	17/64	–	–	0.2656	2.7/8	4.1/8	0.266
R15BH	–	–	H	0.2660	2.7/8	4.1/8	0.266
R15BI	–	–	I	0.2720	2.7/8	4.1/8	0.272
R15BJ	–	–	J	0.2770	2.7/8	4.1/8	0.277
R15BK	–	–	K	0.2810	2.15/16	4.1/4	0.281
R10B9/32	9/32	–	–	0.2813	2.15/16	4.1/4	0.281

Product	DC	DC	DC	DC	LCF	OAL	DCON MS
	(inch)	(Wire gauge size)	(Letter size)	(inch)	(inch)	(inch)	(inch)
R15BL	–	–	L	0.2900	2.15/16	4.1/4	0.290
R15BM	–	–	M	0.2950	3.1/16	4.3/8	0.295
R10B19/64	19/64	–	–	0.2969	3.1/16	4.3/8	0.297
R15BN	–	–	N	0.3020	3.1/16	4.3/8	0.302
R10B5/16	5/16	–	–	0.3125	3.3/16	4.1/2	0.313
R15B0	–	–	O	0.3160	3.3/16	4.1/2	0.316
R15BP	–	–	P	0.3230	3.5/16	4.5/8	0.323
R10B21/64	21/64	–	–	0.3281	3.5/16	4.5/8	0.328
R15BQ	–	–	Q	0.3320	3.7/16	4.3/4	0.332
R15BR	–	–	R	0.3390	3.7/16	4.3/4	0.339
R10B11/32	11/32	–	–	0.3438	3.7/16	4.3/4	0.344
R15BS	–	–	S	0.3480	3.1/2	4.7/8	0.348
R15BT	–	–	T	0.3580	3.1/2	4.7/8	0.358
R10B23/64	23/64	–	–	0.3594	3.1/2	4.7/8	0.359
R15BU	–	–	U	0.3680	3.5/8	5"	0.368
R10B3/8	3/8	–	–	0.3750	3.5/8	5"	0.375
R15BV	–	–	V	0.3770	3.5/8	5"	0.377
R15BW	–	–	W	0.3860	3.3/4	5.1/8	0.386
R10B25/64	25/64	–	–	0.3906	3.3/4	5.1/8	0.391
R15BX	–	–	X	0.3970	3.3/4	5.1/8	0.397
R15BY	–	–	Y	0.4040	3.7/8	5.1/4	0.404
R10B13/32	13/32	–	–	0.4063	3.7/8	5.1/4	0.406
R15BZ	–	–	Z	0.4130	3.7/8	5.1/4	0.413
R10B27/64	27/64	–	–	0.4219	3.15/16	5.3/8	0.422
R10B7/16	7/16	–	–	0.4375	4.1/16	5.1/2	0.438
R10B29/64	29/64	–	–	0.4531	4.3/16	5.5/8	0.453
R10B15/32	15/32	–	–	0.4688	4.5/16	5.3/4	0.469
R10B31/64	31/64	–	–	0.4844	4.3/8	5.7/8	0.484
R10B1/2	1/2	–	–	0.5000	4.1/2	6"	0.500

500-6/501-6/502-6

PRECISION



Foret extra-long en HSS, type B NAS 907 avec OAL de 6"

Les forets de la série longue, fabriqués conformément aux normes aéronautiques nationales (NAS), ont une longueur totale importante combinée à une longueur de goujure courte, ce qui les rend idéaux pour le perçage des zones difficiles d'accès. La pointe en croix 135° autocentrante et le traitement vapeur permettent de percer la plupart des matériaux.

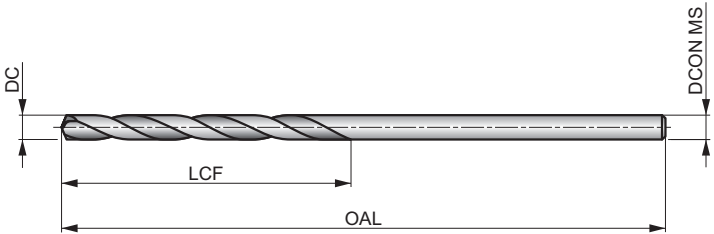

HSS	NAS 907	4xD
135°	ST	
λ 20-35°	R	

Adéquation du groupe de matériaux de la pièce, valeurs de départ pour la vitesse de coupe (m/min) et code Alpha d'avance. Les tableaux d'avances par tour se trouvent à partir de la page 274.

P2.2 ■ 25 F	P2.3 ■ 22 E	P3.1 ■ 19 F	P3.2 ■ 15 F	P3.3 ■ 13 E	P4.1 ■ 11 F	P4.2 ■ 10 E	P4.3 ■ 8 D	M1.1 ■ 21 E	M1.2 ■ 17 E	M2.1 ■ 18 E	M2.2 ■ 15 E	M3.1 ■ 9 G	M3.2 ■ 8 G
M3.3 ■ 7 C	M4.1 ■ 9 C	K1.1 ■ 30 I	K1.2 ■ 22 F	K1.3 ■ 17 F	K2.1 ■ 25 E	K2.2 ■ 20 E	K2.3 ■ 16 E	K3.1 ■ 22 E	K3.2 ■ 17 E	K3.3 ■ 13 E	K4.1 ■ 20 E	K4.2 ■ 15 E	K4.3 ■ 11 E
K4.4 ■ 10 E	K4.5 ■ 8 E	K5.1 ■ 23 E	K5.2 ■ 17 E	K5.3 ■ 13 E	N2.2 ■ 27 G	N2.3 ■ 24 F	N3.1 ■ 27 H	N3.2 ■ 21 H	N3.3 ■ 16 G	S1.1 ■ 23 F	S1.2 ■ 12 D	S1.3 ■ 6 B	S2.1 ■ 8 E
S2.2 ■ 4 A	S3.1 ■ 6 E	S3.2 ■ 3 A	S4.1 ■ 5 E	S4.2 ■ 2 A									

Product	DC (inch)	DC (Wire gauge size)	DC (Letter size)	DC (inch)	LCF (inch)	OAL (inch)	DCON MS (inch)
501-6N60 ¹⁾	-	N60	-	0.0400	11/16	6"	0.040
501-6N59 ¹⁾	-	N59	-	0.0410	11/16	6"	0.041
501-6N58 ¹⁾	-	N58	-	0.0420	11/16	6"	0.042
501-6N57 ¹⁾	-	N57	-	0.0430	3/4	6"	0.043
501-6N56 ¹⁾	-	N56	-	0.0465	3/4	6"	0.046
500-63/64 ¹⁾	3/64	-	-	0.0469	3/4	6"	0.047
501-6N55 ¹⁾	-	N55	-	0.0520	7/8	6"	0.052
501-6N54 ¹⁾	-	N54	-	0.0550	7/8	6"	0.055
501-6N53 ¹⁾	-	N53	-	0.0595	7/8	6"	0.059
500-61/16	1/16	-	-	0.0625	7/8	6"	0.063
501-6N52	-	N52	-	0.0635	7/8	6"	0.064
501-6N51	-	N51	-	0.0670	1"	6"	0.067
501-6N50	-	N50	-	0.0700	1"	6"	0.070
501-6N49	-	N49	-	0.0730	1"	6"	0.073
501-6N48	-	N48	-	0.0760	1"	6"	0.076
500-65/64	5/64	-	-	0.0781	1"	6"	0.078
501-6N47	-	N47	-	0.0785	1"	6"	0.079
501-6N46	-	N46	-	0.0810	1.1/8	6"	0.081
501-6N45	-	N45	-	0.0820	1.1/8	6"	0.082
501-6N44	-	N44	-	0.0860	1.1/8	6"	0.086
501-6N43	-	N43	-	0.0890	1.1/4	6"	0.089
501-6N42	-	N42	-	0.0935	1.1/4	6"	0.093
500-63/32	3/32	-	-	0.0938	1.1/4	6"	0.094
501-6N41	-	N41	-	0.0960	1.3/8	6"	0.096
501-6N40	-	N40	-	0.0980	1.3/8	6"	0.098
501-6N39	-	N39	-	0.0995	1.3/8	6"	0.100

Product	DC (inch)	DC (Wire gauge size)	DC (Letter size)	DC (inch)	LCF (inch)	OAL (inch)	DCON MS (inch)
501-6N38	-	N38	-	0.1015	1.7/16	6"	0.102
501-6N37	-	N37	-	0.1040	1.7/16	6"	0.104
501-6N36	-	N36	-	0.1065	1.7/16	6"	0.106
500-67/64	7/64	-	-	0.1094	1.1/2	6"	0.109
501-6N35	-	N35	-	0.1100	1.1/2	6"	0.110
501-6N34	-	N34	-	0.1110	1.1/2	6"	0.111
501-6N33	-	N33	-	0.1130	1.1/2	6"	0.113
501-6N32	-	N32	-	0.1160	1.5/8	6"	0.116
501-6N31	-	N31	-	0.1200	1.5/8	6"	0.120
500-61/8	1/8	-	-	0.1250	1.5/8	6"	0.125
501-6N30	-	N30	-	0.1285	1.5/8	6"	0.129
501-6N29	-	N29	-	0.1360	1.3/4	6"	0.136
501-6N28	-	N28	-	0.1405	1.3/4	6"	0.141
500-69/64	9/64	-	-	0.1406	1.3/4	6"	0.141
501-6N27	-	N27	-	0.1440	1.7/8	6"	0.144
501-6N26	-	N26	-	0.1470	1.7/8	6"	0.147
501-6N25	-	N25	-	0.1495	1.7/8	6"	0.149
501-6N24	-	N24	-	0.1520	2"	6"	0.152
501-6N23	-	N23	-	0.1540	2"	6"	0.154
500-65/32	5/32	-	-	0.1563	2"	6"	0.156
501-6N22	-	N22	-	0.1570	2"	6"	0.157
501-6N21	-	N21	-	0.1590	2.1/8	6"	0.159
501-6N20	-	N20	-	0.1610	2.1/8	6"	0.161
501-6N19	-	N19	-	0.1660	2.1/8	6"	0.166
501-6N18	-	N18	-	0.1695	2.1/8	6"	0.170
500-611/64	11/64	-	-	0.1719	2.1/8	6"	0.172



Product	DC	DC	DC	DC	LCF	OAL	DCON
	(inch)	(Wire gauge size)	(Letter size)	(inch)	(inch)	(inch)	MS (inch)
501-6N17	–	N17	–	0.1730	2.3/16	6"	0.173
501-6N16	–	N16	–	0.1770	2.3/16	6"	0.177
501-6N15	–	N15	–	0.1800	2.3/16	6"	0.180
501-6N14	–	N14	–	0.1820	2.3/16	6"	0.182
501-6N13	–	N13	–	0.1850	2.5/16	6"	0.185
500-63/16	3/16	–	–	0.1875	2.5/16	6"	0.188
501-6N12	–	N12	–	0.1890	2.5/16	6"	0.189
501-6N11	–	N11	–	0.1910	2.5/16	6"	0.191
501-6N10	–	N10	–	0.1935	2.7/16	6"	0.194
501-6N9	–	N9	–	0.1960	2.7/16	6"	0.196
501-6N8	–	N8	–	0.1990	2.7/16	6"	0.199
501-6N7	–	N7	–	0.2010	2.7/16	6"	0.201
500-613/64	13/64	–	–	0.2031	2.7/16	6"	0.203
501-6N6	–	N6	–	0.2040	2.1/2	6"	0.204
501-6N5	–	N5	–	0.2055	2.1/2	6"	0.205
501-6N4	–	N4	–	0.2090	2.1/2	6"	0.209
501-6N3	–	N3	–	0.2130	2.1/2	6"	0.213
500-67/32	7/32	–	–	0.2188	2.1/2	6"	0.219
501-6N2	–	N2	–	0.2210	2.5/8	6"	0.221
501-6N1	–	N1	–	0.2280	2.5/8	6"	0.228
502-6A	–	–	A	0.2340	2.5/8	6"	0.234
500-615/64	15/64	–	–	0.2344	2.5/8	6"	0.234
502-6B	–	–	B	0.2380	2.3/4	6"	0.238
502-6C	–	–	C	0.2420	2.3/4	6"	0.242
502-6D	–	–	D	0.2460	2.3/4	6"	0.246
500-61/4	1/4	–	–	0.2500	2.3/4	6"	0.250
502-6F	–	–	F	0.2570	2.7/8	6"	0.257
502-6G	–	–	G	0.2610	2.7/8	6"	0.261
500-617/64	17/64	–	–	0.2656	2.7/8	6"	0.266
502-6H	–	–	H	0.2660	2.7/8	6"	0.266
502-6I	–	–	I	0.2720	2.7/8	6"	0.272
502-6J	–	–	J	0.2770	2.7/8	6"	0.277

¹⁾ Pas de pointe en croix.

Product	DC	DC	DC	DC	LCF	OAL	DCON
	(inch)	(Wire gauge size)	(Letter size)	(inch)	(inch)	(inch)	MS (inch)
502-6K	–	–	K	0.2810	2.15/16	6"	0.281
500-69/32	9/32	–	–	0.2813	2.15/16	6"	0.281
502-6L	–	–	L	0.2900	2.15/16	6"	0.290
502-6M	–	–	M	0.2950	3.1/16	6"	0.295
500-619/64	19/64	–	–	0.2969	3.1/16	6"	0.297
502-6N	–	–	N	0.3020	3.1/16	6"	0.302
500-65/16	5/16	–	–	0.3125	3.3/16	6"	0.313
502-6O	–	–	O	0.3160	3.3/16	6"	0.316
502-6P	–	–	P	0.3230	3.5/16	6"	0.323
500-621/64	21/64	–	–	0.3281	3.5/16	6"	0.328
502-6Q	–	–	Q	0.3320	3.7/16	6"	0.332
502-6R	–	–	R	0.3390	3.7/16	6"	0.339
500-611/32	11/32	–	–	0.3438	3.7/16	6"	0.344
502-6S	–	–	S	0.3480	3.1/2	6"	0.348
502-6T	–	–	T	0.3580	3.1/2	6"	0.358
500-623/64	23/64	–	–	0.3594	3.1/2	6"	0.359
502-6U	–	–	U	0.3680	3.5/8	6"	0.368
500-63/8	3/8	–	–	0.3750	3.5/8	6"	0.375
502-6V	–	–	V	0.3772	3.5/8	6"	0.377
502-6W	–	–	W	0.3860	3.3/4	6"	0.386
500-625/64	25/64	–	–	0.3906	3.3/4	6"	0.391
502-6X	–	–	X	0.3970	3.3/4	6"	0.397
502-6Y	–	–	Y	0.4040	3.7/8	6"	0.404
500-613/32	13/32	–	–	0.4063	3.7/8	6"	0.406
502-6Z	–	–	Z	0.4130	3.7/8	6"	0.413
500-627/64	27/64	–	–	0.4219	3.15/16	6"	0.422
500-67/16	7/16	–	–	0.4375	4.1/16	6"	0.438
500-629/64	29/64	–	–	0.4531	4.3/16	6"	0.453
500-615/32	15/32	–	–	0.4688	4.5/16	6"	0.469
500-631/64	31/64	–	–	0.4844	4.3/8	6"	0.484
500-61/2	1/2	–	–	0.5000	4.1/2	6"	0.500

500-12/501-12/502-12

PRECISION



Foret extra-long en HSS, type B NAS 907 avec OAL de 12"

Les forets de la série extra-longue, fabriqués conformément aux normes aéronautiques nationales (NAS), ont une longueur totale extra-longue combinée à une longueur de goujure courte, ce qui les rend idéaux pour le perçage des zones difficiles d'accès. La pointe en croix autocentrante à 135° et le traitement vapeur permettent de percer la plupart des matériaux.

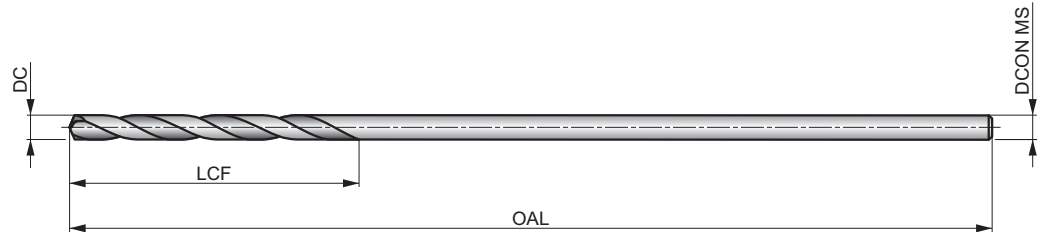

HSS	NAS 907	4xD
135°	ST	
λ 20-35°	R	

Adéquation du groupe de matériaux de la pièce, valeurs de départ pour la vitesse de coupe (m/min) et code Alpha d'avance. Les tableaux d'avances par tour se trouvent à partir de la page 274.

P2.2 ■ 25 F	P2.3 ■ 22 E	P3.1 ■ 19 F	P3.2 ■ 15 F	P3.3 ■ 13 E	P4.1 ■ 11 F	P4.2 ■ 10 E	P4.3 ■ 8 D	M1.1 ■ 21 E	M1.2 ■ 17 E	M2.1 ■ 18 E	M2.2 ■ 15 E	M3.1 ■ 9 G	M3.2 ■ 8 G
M3.3 ■ 7 C	M4.1 ■ 9 C	K1.1 ■ 30 I	K1.2 ■ 22 F	K1.3 ■ 17 F	K2.1 ■ 25 E	K2.2 ■ 20 E	K2.3 ■ 16 E	K3.1 ■ 22 E	K3.2 ■ 17 E	K3.3 ■ 13 E	K4.1 ■ 20 E	K4.2 ■ 15 E	K4.3 ■ 11 E
K4.4 ■ 10 E	K4.5 ■ 8 E	K5.1 ■ 23 E	K5.2 ■ 17 E	K5.3 ■ 13 E	N2.2 ■ 27 G	N2.3 ■ 24 F	N3.1 ■ 27 H	N3.2 ■ 21 H	N3.3 ■ 16 G	S1.1 ■ 23 F	S1.2 ■ 12 D	S1.3 ■ 6 B	S2.1 ■ 8 E
S2.2 ■ 4 A	S3.1 ■ 6 E	S3.2 ■ 3 A	S4.1 ■ 5 E	S4.2 ■ 2 A									

Product	DC	DC	DC	DC	LCF	OAL	DCON MS
	(inch)	(Wire gauge size)	(Letter size)	(inch)	(inch)	(inch)	(inch)
500-123/64	3/64	-	-	0.0469	3/4	12"	0.047
500-121/16	1/16	-	-	0.0625	7/8	12"	0.063
501-12N50	-	N50	-	0.0700	1"	12"	0.070
501-12N49	-	N49	-	0.0730	1"	12"	0.073
500-125/64	5/64	-	-	0.0781	1"	12"	0.078
501-12N47	-	N47	-	0.0785	1"	12"	0.079
501-12N46	-	N46	-	0.0810	1.1/8	12"	0.081
501-12N45	-	N45	-	0.0820	1.1/8	12"	0.082
501-12N44	-	N44	-	0.0860	1.1/8	12"	0.086
501-12N43	-	N43	-	0.0890	1.1/4	12"	0.089
501-12N42	-	N42	-	0.0935	1.1/4	12"	0.093
500-123/32	3/32	-	-	0.0938	1.1/4	12"	0.094
501-12N41	-	N41	-	0.0960	1.3/8	12"	0.096
501-12N40	-	N40	-	0.0980	1.3/8	12"	0.098
501-12N37	-	N37	-	0.1040	1.7/16	12"	0.104
501-12N36	-	N36	-	0.1065	1.7/16	12"	0.106
500-127/64	7/64	-	-	0.1094	1.1/2	12"	0.109
501-12N31	-	N31	-	0.1200	1.5/8	12"	0.120
500-121/8	1/8	-	-	0.1250	1.5/8	12"	0.125
501-12N30	-	N30	-	0.1285	1.5/8	12"	0.129
501-12N29	-	N29	-	0.1360	1.3/4	12"	0.136
500-129/64	9/64	-	-	0.1406	1.3/4	12"	0.141
501-12N27	-	N27	-	0.1440	1.7/8	12"	0.144
501-12N26	-	N26	-	0.1470	1.7/8	12"	0.147
501-12N25	-	N25	-	0.1495	1.7/8	12"	0.149
501-12N23	-	N23	-	0.1540	2"	12"	0.154

Product	DC	DC	DC	DC	LCF	OAL	DCON MS
	(inch)	(Wire gauge size)	(Letter size)	(inch)	(inch)	(inch)	(inch)
500-125/32	5/32	-	-	0.1563	2"	12"	0.156
501-12N22	-	N22	-	0.1570	2"	12"	0.157
501-12N21	-	N21	-	0.1590	2.1/8	12"	0.159
501-12N20	-	N20	-	0.1610	2.1/8	12"	0.161
501-12N19	-	N19	-	0.1660	2.1/8	12"	0.166
501-12N18	-	N18	-	0.1695	2.1/8	12"	0.170
500-1211/64	11/64	-	-	0.1719	2.1/8	12"	0.172
501-12N17	-	N17	-	0.1730	2.3/16	12"	0.173
501-12N16	-	N16	-	0.1770	2.3/16	12"	0.177
501-12N13	-	N13	-	0.1850	2.5/16	12"	0.185
500-123/16	3/16	-	-	0.1875	2.5/16	12"	0.188
501-12N12	-	N12	-	0.1890	2.5/16	12"	0.189
501-12N11	-	N11	-	0.1910	2.5/16	12"	0.191
501-12N10	-	N10	-	0.1935	2.7/16	12"	0.194
501-12N9	-	N9	-	0.1960	2.7/16	12"	0.196
501-12N7	-	N7	-	0.2010	2.7/16	12"	0.201
500-1213/64	13/64	-	-	0.2031	2.7/16	12"	0.203
501-12N5	-	N5	-	0.2055	2.1/2	12"	0.205
501-12N4	-	N4	-	0.2090	2.1/2	12"	0.209
501-12N3	-	N3	-	0.2130	2.1/2	12"	0.213
500-127/32	7/32	-	-	0.2188	2.1/2	12"	0.219
501-12N1	-	N1	-	0.2280	2.5/8	12"	0.228
502-12A	-	-	A	0.2340	2.5/8	12"	0.234
500-1215/64	15/64	-	-	0.2344	2.5/8	12"	0.234
502-12B	-	-	B	0.2380	2.3/4	12"	0.238
502-12C	-	-	C	0.2420	2.3/4	12"	0.242



Product	DC	DC	DC	DC	LCF	OAL	DCON MS
	(inch)	(Wire gauge size)	(Letter size)	(inch)	(inch)	(inch)	(inch)
502-12D	–	–	D	0.2460	2.3/4	12"	0.246
500-121/4	1/4	–	–	0.2500	2.3/4	12"	0.250
502-12F	–	–	F	0.2570	2.7/8	12"	0.257
502-12G	–	–	G	0.2610	2.7/8	12"	0.261
500-1217/64	17/64	–	–	0.2656	2.7/8	12"	0.266
502-12H	–	–	H	0.2660	2.7/8	12"	0.266
502-12I	–	–	I	0.2720	2.7/8	12"	0.272
502-12J	–	–	J	0.2770	2.7/8	12"	0.277
502-12K	–	–	K	0.2810	2.15/16	12"	0.281
500-129/32	9/32	–	–	0.2813	2.15/16	12"	0.281
502-12L	–	–	L	0.2900	2.15/16	12"	0.290
502-12M	–	–	M	0.2950	3.1/16	12"	0.295
500-1219/64	19/64	–	–	0.2969	3.1/16	12"	0.297
502-12N	–	–	N	0.3020	3.1/16	12"	0.302
500-125/16	5/16	–	–	0.3125	3.3/16	12"	0.313
502-12O	–	–	O	0.3160	3.3/16	12"	0.316
502-12P	–	–	P	0.3230	3.5/16	12"	0.323
500-1221/64	21/64	–	–	0.3281	3.5/16	12"	0.328
502-12Q	–	–	Q	0.3320	3.7/16	12"	0.332
502-12R	–	–	R	0.3390	3.7/16	12"	0.339

Product	DC	DC	DC	DC	LCF	OAL	DCON MS
	(inch)	(Wire gauge size)	(Letter size)	(inch)	(inch)	(inch)	(inch)
500-1211/32	11/32	–	–	0.3438	3.7/16	12"	0.344
502-12S	–	–	S	0.3480	3.1/2	12"	0.348
502-12T	–	–	T	0.3580	3.1/2	12"	0.358
500-1223/64	23/64	–	–	0.3594	3.1/2	12"	0.359
502-12U	–	–	U	0.3680	3.5/8	12"	0.368
500-123/8	3/8	–	–	0.3750	3.5/8	12"	0.375
502-12V	–	–	V	0.3770	3.5/8	12"	0.377
502-12W	–	–	W	0.3860	3.3/4	12"	0.386
500-1225/64	25/64	–	–	0.3906	3.3/4	12"	0.391
502-12X	–	–	X	0.3970	3.3/4	12"	0.397
502-12Y	–	–	Y	0.4040	3.7/8	12"	0.404
500-1213/32	13/32	–	–	0.4063	3.7/8	12"	0.406
502-12Z	–	–	Z	0.4130	3.7/8	12"	0.413
500-1227/64	27/64	–	–	0.4219	3.15/16	12"	0.422
500-127/16	7/16	–	–	0.4375	4.1/16	12"	0.438
500-1229/64	29/64	–	–	0.4531	4.3/16	12"	0.453
500-1215/32	15/32	–	–	0.4688	4.5/16	12"	0.469
500-1231/64	31/64	–	–	0.4844	4.3/8	12"	0.484
500-121/2	1/2	–	–	0.5000	4.1/2	12"	0.500

R88CO/R89CO

PRECISION



Foret court en HSS-E (8% de Cobalt), type D NAS 907 pour perçage intensif.

Foret court avec une goujure plus courte et une queue plus longue pour plus de rigidité. Excellent foret lorsqu'une plus grande portée est nécessaire pour percer des trous peu profonds ou des pièces plus minces. La finition bronze avec une pointe en croix à 135° autocentrante à faible poussée pour faciliter la pénétration. Fabriqué selon les normes aérospatiales NAS 907 Type D.

HSS-E	NAS 907	3xD

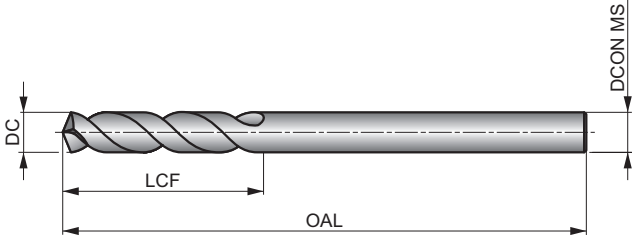

Adéquation du groupe de matériaux de la pièce, valeurs de départ pour la vitesse de coupe (m/min) et code Alpha d'avance. Les tableaux d'avances par tour se trouvent à partir de la page 274.

P1.1 ■ 36 H	P1.2 ■ 40 H	P1.3 ■ 41 H	P2.1 ■ 31 H	P2.2 ■ 27 G	P2.3 ■ 24 E	P3.1 ■ 25 F	P3.2 ■ 20 F	P3.3 ■ 17 E	P4.1 ■ 15 F	P4.2 ■ 13 E	P4.3 ■ 10 D	M1.1 ■ 30 E	M1.2 ■ 26 E
M2.1 ■ 27 E	M2.2 ■ 22 E	M2.3 ■ 18 C	M3.1 ■ 13 G	M3.2 ■ 11 G	M3.3 ■ 10 C	M4.1 ■ 15 C	K1.1 ■ 35 H	K1.2 ■ 26 D	K1.3 ■ 19 D	K2.1 ■ 27 E	K2.2 ■ 22 E	K2.3 ■ 18 E	K3.1 ■ 24 E
K3.2 ■ 18 E	K3.3 ■ 15 E	K4.1 ■ 22 E	K4.2 ■ 17 E	K4.3 ■ 12 E	K4.4 ■ 11 E	K4.5 ■ 9 E	K5.1 ■ 25 E	K5.2 ■ 19 E	K5.3 ■ 15 E	N1.1 ■ 33 J	N1.2 ■ 25 J	N1.3 ■ 17 I	N2.1 ■ 46 H
N2.2 ■ 42 H	N2.3 ■ 30 H	N3.1 ■ 68 H	N3.2 ■ 40 F	N3.3 ■ 20 H	S1.1 ■ 28 F	S1.2 ■ 20 D	S1.3 ■ 11 C	S2.1 ■ 9 E	S2.2 ■ 8 B	S3.1 ■ 7 E	S3.2 ■ 6 B	S4.1 ■ 5 E	S4.2 ■ 5 B

Product	DC	DC	DC	LCF	OAL	DCON MS
	(inch)	(Wire gauge size)	(inch)			
R88C01/16	1/16	—	0.0625	7/16	1.7/8	0.063
R89CON52	—	N52	0.0635	7/16	1.7/8	0.064
R89CON51	—	N51	0.0670	1/2	2"	0.067
R89CON50	—	N50	0.0700	1/2	2"	0.070
R89CON49	—	N49	0.0730	1/2	2"	0.073
R88C05/64	5/64	—	0.0781	1/2	2"	0.078
R89CON46	—	N46	0.0810	9/16	2.1/8	0.081
R89CON45	—	N45	0.0820	9/16	2.1/8	0.082
R89CON44	—	N44	0.0860	9/16	2.1/8	0.086
R89CON43	—	N43	0.0890	5/8	2.1/4	0.089
R89CON42	—	N42	0.0935	5/8	2.1/4	0.093
R88C03/32	3/32	—	0.0938	5/8	2.1/4	0.094
R89CON41	—	N41	0.0960	5/8	2.3/8	0.096
R89CON40	—	N40	0.0980	13/16	2.3/8	0.098
R89CON39	—	N39	0.0995	13/16	2.3/8	0.100
R89CON36	—	N36	0.1065	13/16	2.1/2	0.106
R88C07/64	7/64	—	0.1094	13/16	2.5/8	0.109
R89CON31	—	N31	0.1200	7/8	2.3/4	0.120
R88C01/8	1/8	—	0.1250	7/8	2.3/4	0.125
R89CON30	—	N30	0.1285	15/16	2.3/4	0.129
R89CON29	—	N29	0.1360	15/16	2.7/8	0.136
R88C09/64	9/64	—	0.1406	15/16	2.7/8	0.141
R89CON27	—	N27	0.1440	1"	3"	0.144
R89CON26	—	N26	0.1470	1"	3"	0.147
R89CON25	—	N25	0.1495	1"	3"	0.149
R89CON24	—	N24	0.1520	1"	3.1/8	0.152
R88C05/32	5/32	—	0.1563	1"	3.1/8	0.156
R89CON22	—	N22	0.1570	1.1/16	3.1/8	0.157
R89CON21	—	N21	0.1590	1.1/16	3.1/4	0.159
R89CON20	—	N20	0.1610	1.1/16	3.1/4	0.161
R88C011/64	11/64	—	0.1719	1.1/16	3.1/4	0.172
R89CON16	—	N16	0.1770	1.1/8	3.3/8	0.177

Product	DC	DC	DC	LCF	OAL	DCON MS
	(inch)	(Wire gauge size)	(inch)			
R89CON13	—	N13	0.1850	1.1/8	3.1/2	0.185
R88C03/16	3/16	—	0.1875	1.1/8	3.1/2	0.188
R89CON12	—	N12	0.1890	1.1/8	3.1/2	0.189
R89CON11	—	N11	0.1910	1.3/16	3.1/2	0.191
R89CON10	—	N10	0.1935	1.3/16	3.5/8	0.194
R89CON9	—	N9	0.1960	1.3/16	3.5/8	0.196
R89CON8	—	N8	0.1990	1.3/16	3.5/8	0.199
R89CON7	—	N7	0.2010	1.3/16	3.5/8	0.201
R88C013/64	13/64	—	0.2031	1.3/16	3.5/8	0.203
R89CON6	—	N6	0.2040	1.1/4	3.3/4	0.204
R89CON5	—	N5	0.2055	1.1/4	3.3/4	0.205
R89CON3	—	N3	0.2130	1.1/4	3.3/4	0.213
R88C07/32	7/32	—	0.2188	1.1/4	3.3/4	0.219
R88C015/64	15/64	—	0.2344	1.5/16	3.7/8	0.234
R88C01/4	1/4	—	0.2500	1.3/8	4"	0.250
R88C017/64	17/64	—	0.2656	1.7/16	4.1/8	0.266
R88C09/32	9/32	—	0.2813	1.1/2	4.1/4	0.281
R88C019/64	19/64	—	0.2969	1.9/16	4.3/8	0.297
R88C05/16	5/16	—	0.3125	1.5/8	4.1/2	0.313
R88C021/64	21/64	—	0.3281	1.11/16	4.5/8	0.328
R88C011/32	11/32	—	0.3438	1.11/16	4.3/4	0.344
R88C023/64	23/64	—	0.3594	1.3/4	4.7/8	0.359
R88C03/8	3/8	—	0.3750	1.13/16	5"	0.375
R88C025/64	25/64	—	0.3906	1.7/8	5.1/8	0.391
R88C013/32	13/32	—	0.4063	1.15/16	5.1/4	0.406
R88C027/64	27/64	—	0.4219	2"	5.3/8	0.422
R88C07/16	7/16	—	0.4375	2.1/16	5.1/2	0.438
R88C029/64	29/64	—	0.4531	2.1/8	5.5/8	0.453
R88C015/32	15/32	—	0.4688	2.1/8	5.3/4	0.469
R88C031/64	31/64	—	0.4844	2.3/16	5.7/8	0.484
R88C01/2	1/2	—	0.5000	2.1/4	6"	0.500

R10CO/R15CO/R18CO

PRECISION



Foret court en HSS-E (8% de Cobalt), type J NAS 907 pour perçage intensif.

Très performant, il produit des trous de diamètre précis avec une meilleure finition. Pointe en croix à 135° autocentrante à faible poussée pour faciliter la pénétration. La finition bronze empêche le matériau de la pièce de coller aux arêtes de coupe du foret. Fabriqué selon les normes aérospatiales NAS 907 Type J.

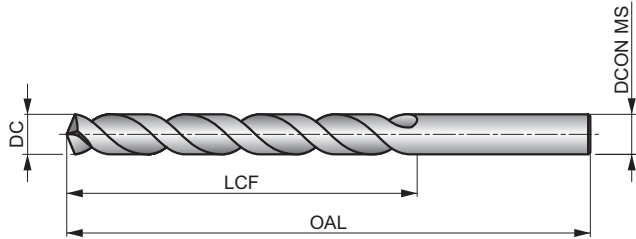

HSS-E	NAS 907	4xD
135°	Bronze	
λ 20-35°	R	

Adéquation du groupe de matériaux de la pièce, valeurs de départ pour la vitesse de coupe (m/min) et code Alpha d'avance. Les tableaux d'avances par tour se trouvent à partir de la page 274.

P1.1 ▣36 H	P1.2 ▣40 H	P1.3 ▣41 H	P2.1 ▣31 H	P2.2 ▣27 G	P2.3 ▣24 E	P3.1 ▣25 F	P3.2 ▣20 F	P3.3 ▣17 E	P4.1 ▣15 F	P4.2 ▣13 E	P4.3 ▣10 D	M1.1 ▣30 E	M1.2 ▣26 E
M2.1 ▣27 E	M2.2 ▣22 E	M2.3 ▣18 C	M3.1 ▣13 G	M3.2 ▣11 G	M3.3 ▣10 C	M4.1 ▣15 C	K1.1 ▣35 H	K1.2 ▣26 D	K1.3 ▣19 D	K2.1 ▣27 E	K2.2 ▣22 E	K2.3 ▣18 E	K3.1 ▣24 E
K3.2 ▣18 E	K3.3 ▣15 E	K4.1 ▣22 E	K4.2 ▣17 E	K4.3 ▣12 E	K4.4 ▣11 E	K4.5 ▣9 E	K5.1 ▣25 E	K5.2 ▣19 E	K5.3 ▣15 E	N1.1 ▣33 J	N1.2 ▣25 J	N1.3 ▣17 I	N2.1 ▣46 H
N2.2 ▣42 H	N2.3 ▣30 H	N3.1 ▣68 H	N3.2 ▣40 F	N3.3 ▣20 H	S1.1 ▣28 F	S1.2 ▣20 D	S1.3 ▣11 C	S2.1 ▣9 E	S2.2 ▣8 B	S3.1 ▣7 E	S3.2 ▣6 B	S4.1 ▣5 E	S4.2 ▣5 B

Product	DC (inch)	DC (Wire gauge size)	DC (Letter size)	DC (inch)	LCF (inch)	OAL (inch)	DCON MS (inch)
R18CON80 ¹⁾	–	N80	–	0.0135	1/8	3/4	0.013
R18CON79 ¹⁾	–	N79	–	0.0145	1/8	3/4	0.015
R10C01/64 ¹⁾	1/64	–	–	0.0156	3/16	3/4	0.016
R18CON78 ¹⁾	–	N78	–	0.0160	3/16	7/8	0.016
R18CON77 ¹⁾	–	N77	–	0.0180	3/16	7/8	0.018
R18CON76 ¹⁾	–	N76	–	0.0200	3/16	7/8	0.020
R18CON75 ¹⁾	–	N75	–	0.0210	1/4	1"	0.021
R18CON74 ¹⁾	–	N74	–	0.0225	1/4	1"	0.022
R18CON73 ¹⁾	–	N73	–	0.0240	5/16	1.1/8	0.024
R18CON72 ¹⁾	–	N72	–	0.0250	5/16	1.1/8	0.025
R18CON71 ¹⁾	–	N71	–	0.0260	3/8	1.1/4	0.026
R18CON70 ¹⁾	–	N70	–	0.0280	3/8	1.1/4	0.028
R18CON69 ¹⁾	–	N69	–	0.0292	1/2	1.3/8	0.029
R18CON68 ¹⁾	–	N68	–	0.0310	1/2	1.3/8	0.031
R10C01/32 ¹⁾	1/32	–	–	0.0313	1/2	1.3/8	0.031
R18CON67 ¹⁾	–	N67	–	0.0320	1/2	1.3/8	0.032
R18CON66 ¹⁾	–	N66	–	0.0330	1/2	1.3/8	0.033
R18CON65 ¹⁾	–	N65	–	0.0350	5/8	1.1/2	0.035
R18CON64 ¹⁾	–	N64	–	0.0360	5/8	1.1/2	0.036
R18CON63 ¹⁾	–	N63	–	0.0370	5/8	1.1/2	0.037
R18CON62 ¹⁾	–	N62	–	0.0380	5/8	1.1/2	0.038
R18CON61 ¹⁾	–	N61	–	0.0390	11/16	1.5/8	0.039
R18CON60	–	N60	–	0.0400	11/16	1.5/8	0.040
R18CON59	–	N59	–	0.0410	11/16	1.5/8	0.041
R18CON58	–	N58	–	0.0420	11/16	1.5/8	0.042
R18CON57	–	N57	–	0.0430	3/4	1.3/4	0.043

Product	DC (inch)	DC (Wire gauge size)	DC (Letter size)	DC (inch)	LCF (inch)	OAL (inch)	DCON MS (inch)
R18CON56	–	N56	–	0.0465	3/4	1.3/4	0.046
R10C03/64	3/64	–	–	0.0469	3/4	1.3/4	0.047
R18CON55	–	N55	–	0.0520	7/8	1.7/8	0.052
R18CON54	–	N54	–	0.0550	7/8	1.7/8	0.055
R18CON53	–	N53	–	0.0595	7/8	1.7/8	0.059
R10C01/16	1/16	–	–	0.0625	7/8	1.7/8	0.063
R18CON52	–	N52	–	0.0635	7/8	1.7/8	0.064
R18CON51	–	N51	–	0.0670	1"	2"	0.067
R18CON50	–	N50	–	0.0700	1"	2"	0.070
R18CON49	–	N49	–	0.0730	1"	2"	0.073
R18CON48	–	N48	–	0.0760	1"	2"	0.076
R10C05/64	5/64	–	–	0.0781	1"	2"	0.078
R18CON47	–	N47	–	0.0785	1"	2"	0.079
R18CON46	–	N46	–	0.0810	1.1/8	2.1/8	0.081
R18CON45	–	N45	–	0.0820	1.1/8	2.1/8	0.082
R18CON44	–	N44	–	0.0860	1.1/8	2.1/8	0.086
R18CON43	–	N43	–	0.0890	1.1/4	2.1/4	0.089
R18CON42	–	N42	–	0.0935	1.1/4	2.1/4	0.093
R10C03/32	3/32	–	–	0.0938	1.1/4	2.1/4	0.094
R18CON41	–	N41	–	0.0960	1.3/8	2.3/8	0.096
R18CON40	–	N40	–	0.0980	1.3/8	2.3/8	0.098
R18CON39	–	N39	–	0.0995	1.3/8	2.3/8	0.100
R18CON38	–	N38	–	0.1015	1.7/16	2.1/2	0.102
R18CON37	–	N37	–	0.1040	1.7/16	2.1/2	0.104
R18CON36	–	N36	–	0.1065	1.7/16	2.1/2	0.106
R10C07/64	7/64	–	–	0.1094	1.1/2	2.5/8	0.109

Product	DC	DC	DC	DC	LCF	OAL	DCON MS
	(inch)	(Wire gauge size)	(Letter size)	(inch)	(inch)	(inch)	(inch)
R18CON35	–	N35	–	0.1100	1.1/2	2.5/8	0.110
R18CON34	–	N34	–	0.1110	1.1/2	2.5/8	0.111
R18CON33	–	N33	–	0.1130	1.1/2	2.5/8	0.113
R18CON32	–	N32	–	0.1160	1.5/8	2.3/4	0.116
R18CON31	–	N31	–	0.1200	1.5/8	2.3/4	0.120
R10C01/8	1/8	–	–	0.1250	1.5/8	2.3/4	0.125
R18CON30	–	N30	–	0.1285	1.5/8	2.3/4	0.129
R18CON29	–	N29	–	0.1360	1.3/4	2.7/8	0.136
R18CON28	–	N28	–	0.1405	1.3/4	2.7/8	0.141
R10C09/64	9/64	–	–	0.1406	1.3/4	2.7/8	0.141
R18CON27	–	N27	–	0.1440	1.7/8	3"	0.144
R18CON26	–	N26	–	0.1470	1.7/8	3"	0.147
R18CON25	–	N25	–	0.1495	1.7/8	3"	0.149
R18CON24	–	N24	–	0.1520	2"	3.1/8	0.152
R18CON23	–	N23	–	0.1540	2"	3.1/8	0.154
R10C05/32	5/32	–	–	0.1563	2"	3.1/8	0.156
R18CON22	–	N22	–	0.1570	2"	3.1/8	0.157
R18CON21	–	N21	–	0.1590	2.1/8	3.1/4	0.159
R18CON20	–	N20	–	0.1610	2.1/8	3.1/4	0.161
R18CON19	–	N19	–	0.1660	2.1/8	3.1/4	0.166
R18CON18	–	N18	–	0.1695	2.1/8	3.1/4	0.170
R10C011/64	11/64	–	–	0.1719	2.1/8	3.1/4	0.172
R18CON17	–	N17	–	0.1730	2.3/16	3.3/8	0.173
R18CON16	–	N16	–	0.1770	2.3/16	3.3/8	0.177
R18CON15	–	N15	–	0.1800	2.3/16	3.3/8	0.180
R18CON14	–	N14	–	0.1820	2.3/16	3.3/8	0.182
R18CON13	–	N13	–	0.1850	2.5/16	3.1/2	0.185
R10C03/16	3/16	–	–	0.1875	2.5/16	3.1/2	0.188
R18CON12	–	N12	–	0.1890	2.5/16	3.1/2	0.189
R18CON11	–	N11	–	0.1910	2.5/16	3.1/2	0.191
R18CON10	–	N10	–	0.1935	2.7/16	3.5/8	0.194
R18CON9	–	N9	–	0.1960	2.7/16	3.5/8	0.196
R18CON8	–	N8	–	0.1990	2.7/16	3.5/8	0.199
R18CON7	–	N7	–	0.2010	2.7/16	3.5/8	0.201
R10C013/64	13/64	–	–	0.2031	2.7/16	3.5/8	0.203
R18CON6	–	N6	–	0.2040	2.1/2	3.3/4	0.204
R18CON5	–	N5	–	0.2055	2.1/2	3.3/4	0.205
R18CON4	–	N4	–	0.2090	2.1/2	3.3/4	0.209
R18CON3	–	N3	–	0.2130	2.1/2	3.3/4	0.213
R10C07/32	7/32	–	–	0.2188	2.1/2	3.3/4	0.219
R18CON2	–	N2	–	0.2210	2.5/8	3.7/8	0.221
R18CON1	–	N1	–	0.2280	2.5/8	3.7/8	0.228
R15COA	–	–	A	0.2340	2.5/8	3.7/8	0.234
R10C015/64	15/64	–	–	0.2344	2.5/8	3.7/8	0.234
R15COB	–	–	B	0.2380	2.3/4	4"	0.238
R15COC	–	–	C	0.2420	2.3/4	4"	0.242
R15COD	–	–	D	0.2460	2.3/4	4"	0.246
R10C01/4	1/4	–	–	0.2500	2.3/4	4"	0.250
R15COF	–	–	F	0.2570	2.7/8	4.1/8	0.257

¹⁾ Pas de pointe en croix.

Product	DC	DC	DC	DC	LCF	OAL	DCON MS
	(inch)	(Wire gauge size)	(Letter size)	(inch)	(inch)	(inch)	(inch)
R15COG	–	–	G	0.2610	2.7/8	4.1/8	0.261
R10C017/64	17/64	–	–	0.2656	2.7/8	4.1/8	0.266
R15COH	–	–	H	0.2660	2.7/8	4.1/8	0.266
R15COI	–	–	I	0.2720	2.7/8	4.1/8	0.272
R15COJ	–	–	J	0.2770	2.7/8	4.1/8	0.277
R15COK	–	–	K	0.2810	2.15/16	4.1/4	0.281
R10C09/32	9/32	–	–	0.2813	2.15/16	4.1/4	0.281
R15COL	–	–	L	0.2900	2.15/16	4.1/4	0.290
R15COM	–	–	M	0.2950	3.1/16	4.3/8	0.295
R10C019/64	19/64	–	–	0.2969	3.1/16	4.3/8	0.297
R15CON	–	–	N	0.3020	3.1/16	4.3/8	0.302
R10C05/16	5/16	–	–	0.3125	3.3/16	4.1/2	0.313
R15COO	–	–	O	0.3160	3.3/16	4.1/2	0.316
R15COP	–	–	P	0.3230	3.5/16	4.5/8	0.323
R10C021/64	21/64	–	–	0.3281	3.5/16	4.5/8	0.328
R15COQ	–	–	Q	0.3320	3.7/16	4.3/4	0.332
R15COR	–	–	R	0.3390	3.7/16	4.3/4	0.339
R10C011/32	11/32	–	–	0.3438	3.7/16	4.3/4	0.344
R15COS	–	–	S	0.3480	3.1/2	4.7/8	0.348
R15COT	–	–	T	0.3580	3.1/2	4.7/8	0.358
R10C023/64	23/64	–	–	0.3594	3.1/2	4.7/8	0.359
R15COU	–	–	U	0.3680	3.5/8	5"	0.368
R10C03/8	3/8	–	–	0.3750	3.5/8	5"	0.375
R15COV	–	–	V	0.3770	3.5/8	5"	0.377
R15COW	–	–	W	0.3860	3.3/4	5.1/8	0.386
R10C025/64	25/64	–	–	0.3906	3.3/4	5.1/8	0.391
R15COX	–	–	X	0.3970	3.3/4	5.1/8	0.397
R15COY	–	–	Y	0.4040	3.7/8	5.1/4	0.404
R10C013/32	13/32	–	–	0.4063	3.7/8	5.1/4	0.406
R15COZ	–	–	Z	0.4130	3.7/8	5.1/4	0.413
R10C027/64	27/64	–	–	0.4219	3.15/16	5.3/8	0.422
R10C07/16	7/16	–	–	0.4375	4.1/16	5.1/2	0.438
R10C029/64	29/64	–	–	0.4531	4.3/16	5.5/8	0.453
R10C015/32	15/32	–	–	0.4688	4.5/16	5.3/4	0.469
R10C031/64	31/64	–	–	0.4844	4.3/8	5.7/8	0.484
R10C01/2	1/2	–	–	0.5000	4.1/2	6"	0.500
R10C033/64	33/64	–	–	0.5156	4.13/16	6.5/8	0.516
R10C017/32	17/32	–	–	0.5313	4.13/16	6.5/8	0.531
R10C035/64	35/64	–	–	0.5469	4.13/16	6.5/8	0.547
R10C09/16	9/16	–	–	0.5625	4.13/16	6.5/8	0.563
R10C037/64	37/64	–	–	0.5781	4.13/16	6.5/8	0.578
R10C019/32	19/32	–	–	0.5938	5.3/16	7.1/8	0.594
R10C039/64	39/64	–	–	0.6094	5.3/16	7.1/8	0.609
R10C05/8	5/8	–	–	0.6250	5.3/16	7.1/8	0.625
R10C041/64	41/64	–	–	0.6406	5.3/16	7.1/8	0.641
R10C021/32	21/32	–	–	0.6563	5.3/16	7.1/8	0.656
R10C043/64	43/64	–	–	0.6719	5.5/8	7.5/8	0.672
R10C011/16	11/16	–	–	0.6875	5.5/8	7.5/8	0.688

CO500-6/CO501-6

PRECISION



Foret aéronautique extra-long en HSS-E, type B NAS 907 avec OAL de 6"

Les forets de la série longue, fabriqués conformément aux normes aérospatiales nationales (NAS), ont une longueur totale importante combinée à une longueur de goujure courte, ce qui les rend idéaux pour le perçage des zones difficiles d'accès. Le matériau au cobalt, la pointe en croix à 135° et la finition bronze améliorent la durée de vie du foret lors du perçage de la plupart des matériaux.

HSS-E	NAS 907	4xD

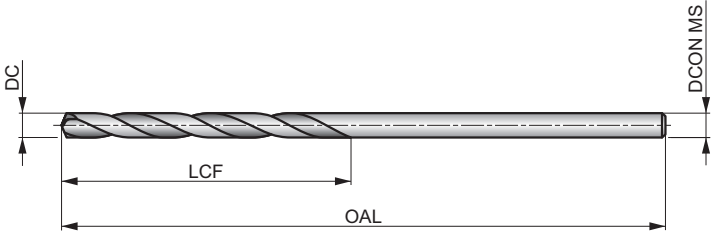

Adéquation du groupe de matériaux de la pièce, valeurs de départ pour la vitesse de coupe (m/min) et code Alpha d'avance. Les tableaux d'avances par tour se trouvent à partir de la page 274.

P1.1 36 G	P1.2 40 G	P1.3 41 G	P2.1 31 G	P2.2 27 E	P2.3 24 D	P3.1 25 E	P3.2 20 E	P3.3 17 D	P4.1 15 E	P4.2 13 D	P4.3 10 B	M1.1 30 H	M1.2 26 H
M2.1 27 H	M2.2 22 H	M2.3 18 D	M3.1 13 F	M3.2 11 F	M3.3 10 D	M4.1 15 D	M4.2 13 D	K1.1 35 H	K1.2 26 H	K1.3 19 H	K2.1 27 F	K2.2 22 F	K2.3 18 D
K3.1 24 F	K3.2 18 F	K3.3 15 D	K4.1 22 F	K4.2 17 F	K4.3 12 D	K4.4 11 D	K4.5 9 D	K5.1 25 F	K5.2 19 F	K5.3 15 D	N1.1 32 I	N1.2 24 I	N1.3 16 H
N2.1 42 G	N2.2 37 G	N2.3 27 G	N3.1 54 G	N3.2 32 H	N3.3 16 E	N4.1 35 I	N4.2 26 G	N4.3 12 E	S1.3 6 D	S2.1 8 B	S2.2 7 B	S3.1 6 B	S3.2 5 B
S4.1 5 B	S4.2 4 B												

Product	DC	DC	DC	LCF	OAL	DCON MS
	(inch)	(Wire gauge size)	(inch)	(inch)	(inch)	(inch)
CO500-61/16	1/16	-	0.0625	7/8	6"	0.063
CO501-6N52	-	N52	0.0635	7/8	6"	0.064
CO501-6N51	-	N51	0.0670	1"	6"	0.067
CO501-6N50	-	N50	0.0700	1"	6"	0.070
CO501-6N49	-	N49	0.0730	1"	6"	0.073
CO501-6N48	-	N48	0.0760	1"	6"	0.076
CO500-65/64	5/64	-	0.0781	1"	6"	0.078
CO501-6N47	-	N47	0.0785	1"	6"	0.079
CO501-6N46	-	N46	0.0810	1.1/8	6"	0.081
CO501-6N45	-	N45	0.0820	1.1/8	6"	0.082
CO501-6N44	-	N44	0.0860	1.1/8	6"	0.086
CO501-6N43	-	N43	0.0890	1.1/4	6"	0.089
CO501-6N42	-	N42	0.0935	1.1/4	6"	0.093
CO500-63/32	3/32	-	0.0938	1.1/4	6"	0.094
CO501-6N41	-	N41	0.0960	1.3/8	6"	0.096
CO501-6N40	-	N40	0.0980	1.3/8	6"	0.098
CO501-6N39	-	N39	0.0995	1.3/8	6"	0.100
CO501-6N38	-	N38	0.1015	1.7/16	6"	0.102
CO501-6N37	-	N37	0.1040	1.7/16	6"	0.104
CO501-6N36	-	N36	0.1065	1.7/16	6"	0.106
CO500-67/64	7/64	-	0.1094	1.1/2	6"	0.109
CO501-6N35	-	N35	0.1100	1.1/2	6"	0.110
CO501-6N34	-	N34	0.1110	1.1/2	6"	0.111
CO501-6N33	-	N33	0.1130	1.1/2	6"	0.113
CO501-6N32	-	N32	0.1160	1.5/8	6"	0.116
CO501-6N31	-	N31	0.1200	1.5/8	6"	0.120
CO500-61/8	1/8	-	0.1250	1.5/8	6"	0.125
CO501-6N30	-	N30	0.1285	1.5/8	6"	0.129
CO501-6N29	-	N29	0.1360	1.3/4	6"	0.136
CO501-6N28	-	N28	0.1405	1.3/4	6"	0.141
CO500-69/64	9/64	-	0.1406	1.3/4	6"	0.141
CO501-6N27	-	N27	0.1440	1.7/8	6"	0.144
CO501-6N26	-	N26	0.1470	1.7/8	6"	0.147

Product	DC	DC	DC	LCF	OAL	DCON MS
	(inch)	(Wire gauge size)	(inch)	(inch)	(inch)	(inch)
CO501-6N25	-	N25	0.1495	1.7/8	6"	0.149
CO501-6N24	-	N24	0.1520	2"	6"	0.152
CO501-6N23	-	N23	0.1540	2"	6"	0.154
CO500-65/32	5/32	-	0.1563	2"	6"	0.156
CO501-6N22	-	N22	0.1570	2"	6"	0.157
CO501-6N21	-	N21	0.1590	2.1/8	6"	0.159
CO501-6N20	-	N20	0.1610	2.1/8	6"	0.161
CO501-6N19	-	N19	0.1660	2.1/8	6"	0.166
CO501-6N18	-	N18	0.1695	2.1/8	6"	0.170
CO500-611/64	11/64	-	0.1719	2.1/8	6"	0.172
CO501-6N17	-	N17	0.1730	2.3/16	6"	0.173
CO501-6N16	-	N16	0.1770	2.3/16	6"	0.177
CO501-6N15	-	N15	0.1800	2.3/16	6"	0.180
CO501-6N14	-	N14	0.1820	2.3/16	6"	0.182
CO501-6N13	-	N13	0.1850	2.5/16	6"	0.185
CO500-63/16	3/16	-	0.1875	2.5/16	6"	0.188
CO501-6N12	-	N12	0.1890	2.5/16	6"	0.189
CO501-6N11	-	N11	0.1910	2.5/16	6"	0.191
CO501-6N10	-	N10	0.1935	2.7/16	6"	0.194
CO501-6N9	-	N9	0.1960	2.7/16	6"	0.196
CO501-6N8	-	N8	0.1990	2.7/16	6"	0.199
CO501-6N7	-	N7	0.2010	2.7/16	6"	0.201
CO500-613/64	13/64	-	0.2031	2.7/16	6"	0.203
CO501-6N6	-	N6	0.2040	2.1/2	6"	0.204
CO501-6N5	-	N5	0.2055	2.1/2	6"	0.205
CO501-6N4	-	N4	0.2090	2.1/2	6"	0.209
CO501-6N3	-	N3	0.2130	2.1/2	6"	0.213
CO500-67/32	7/32	-	0.2188	2.1/2	6"	0.219
CO501-6N2	-	N2	0.2210	2.5/8	6"	0.221
CO501-6N1	-	N1	0.2280	2.5/8	6"	0.228
CO500-615/64	15/64	-	0.2344	2.5/8	6"	0.234
CO500-61/4	1/4	-	0.2500	2.3/4	6"	0.250

CO500-12/CO501-12

PRECISION



Foret aéronautique extra-long en HSS-E, type B NAS 907 avec OAL de 12"

Les forets de la série extra-longue, fabriqués conformément aux normes aérospatiales nationales (NAS), ont une longueur totale extra-longue combinée à une longueur de goujure courte, ce qui les rend idéaux pour le perçage dans les zones difficiles d'accès. Le matériau au cobalt, la pointe en croix à 135° et la finition bronze améliorent la durée de vie de l'outil lors du perçage de la plupart des matériaux.

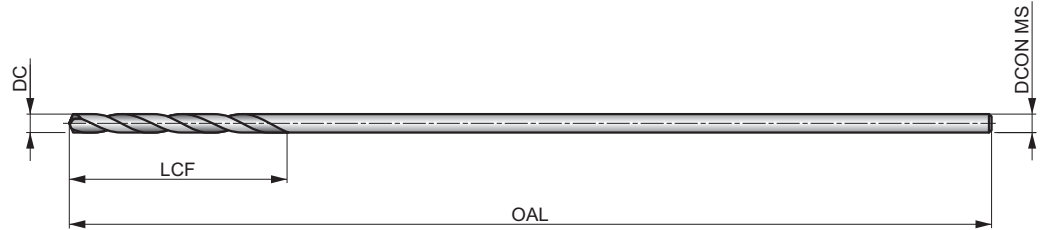

HSS-E	NAS 907	4xD
135°	Bronze	
λ 20-35°	R	

Adéquation du groupe de matériaux de la pièce, valeurs de départ pour la vitesse de coupe (m/min) et code Alpha d'avance. Les tableaux d'avances par tour se trouvent à partir de la page 274.

P1.1 ■ 36 G	P1.2 ■ 40 G	P1.3 ■ 41 G	P2.1 ■ 31 G	P2.2 ■ 27 E	P2.3 ■ 24 D	P3.1 ■ 25 E	P3.2 ■ 20 E	P3.3 ■ 17 D	P4.1 ■ 15 E	P4.2 ■ 13 D	P4.3 ■ 10 B	M1.1 ■ 30 H	M1.2 ■ 26 H
M2.1 ■ 27 H	M2.2 ■ 22 H	M2.3 ■ 18 D	M3.1 ■ 13 F	M3.2 ■ 11 F	M3.3 ■ 10 D	M4.1 ■ 15 D	M4.2 ■ 13 D	K1.1 ■ 35 H	K1.2 ■ 26 H	K1.3 ■ 19 H	K2.1 ■ 27 F	K2.2 ■ 22 F	K2.3 ■ 18 D
K3.1 ■ 24 F	K3.2 ■ 18 F	K3.3 ■ 15 D	K4.1 ■ 22 F	K4.2 ■ 17 F	K4.3 ■ 12 D	K4.4 ■ 11 D	K4.5 ■ 9 D	K5.1 ■ 25 F	K5.2 ■ 19 F	K5.3 ■ 15 D	N1.1 ■ 32 I	N1.2 ■ 24 I	N1.3 ■ 16 H
N2.1 ■ 42 G	N2.2 ■ 37 G	N2.3 ■ 27 G	N3.1 ■ 54 G	N3.2 ■ 32 H	N3.3 ■ 16 E	N4.1 ■ 35 I	N4.2 ■ 26 G	N4.3 ■ 12 E	S1.3 ■ 6 D	S2.1 ■ 8 B	S2.2 ■ 7 B	S3.1 ■ 6 B	S3.2 ■ 5 B
S4.1 ■ 5 B	S4.2 ■ 4 B												

Product	DC (inch)	DC (Wire gauge size)	DC (inch)	LCF (inch)	OAL (inch)	D CON MS (inch)
CO500-121/16	1/16	—	0.0625	7/8	12"	0.063
CO500-125/64	5/64	—	0.0781	1"	12"	0.078
CO500-123/32	3/32	—	0.0938	1.1/4	12"	0.094
CO501-12N40	—	N40	0.0980	1.3/8	12"	0.098
CO500-127/64	7/64	—	0.1094	1.1/2	12"	0.109
CO500-121/8	1/8	—	0.1250	1.5/8	12"	0.125
CO501-12N30	—	N30	0.1285	1.5/8	12"	0.129
CO501-12N29	—	N29	0.1360	1.3/4	12"	0.136
CO500-129/64	9/64	—	0.1406	1.3/4	12"	0.141
CO500-125/32	5/32	—	0.1563	2"	12"	0.156
CO501-12N21	—	N21	0.1590	2.1/8	12"	0.159

Product	DC (inch)	DC (Wire gauge size)	DC (inch)	LCF (inch)	OAL (inch)	D CON MS (inch)
CO501-12N20	—	N20	0.1610	2.1/8	12"	0.161
CO500-1211/64	11/64	—	0.1719	2.1/8	12"	0.172
CO501-12N16	—	N16	0.1770	2.3/16	12"	0.177
CO500-123/16	3/16	—	0.1875	2.5/16	12"	0.188
CO501-12N11	—	N11	0.1910	2.5/16	12"	0.191
CO501-12N10	—	N10	0.1935	2.7/16	12"	0.194
CO500-1213/64	13/64	—	0.2031	2.7/16	12"	0.203
CO500-127/32	7/32	—	0.2188	2.1/2	12"	0.219
CO501-12N2	—	N2	0.2210	2.5/8	12"	0.221
CO500-1215/64	15/64	—	0.2344	2.5/8	12"	0.234
CO500-121/4	1/4	—	0.2500	2.3/4	12"	0.250

2ACO

PRECISION



Foret court en HSS-E, type J NAS 907 pour perçage intensif, finition bronze, dimensions métriques

Très performant, il produit des trous de diamètre précis avec une meilleure finition. Pointe en croix à 135° autocentrante à faible poussée pour faciliter la pénétration. La finition bronze empêche le matériau de la pièce de coller aux arêtes de coupe du foret. Fabriqué selon les normes aérospatiales NAS 907 Type J.

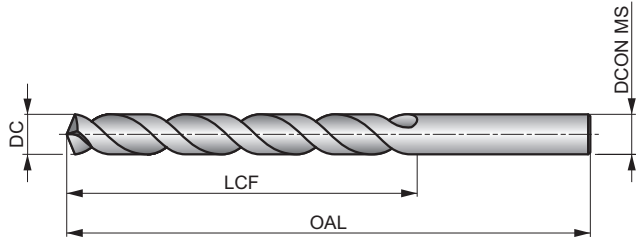

HSS-E	DIN 338	4xD
135°	Bronze	
λ 20-35°	R	

Adéquation du groupe de matériaux de la pièce, valeurs de départ pour la vitesse de coupe (m/min) et code Alpha d'avance. Les tableaux d'avances par tour se trouvent à partir de la page 274.

P1.1 ■ 36 H	P1.2 ■ 40 H	P1.3 ■ 41 H	P2.1 ■ 31 H	P2.2 ■ 27 G	P2.3 ■ 24 E	P3.1 ■ 25 F	P3.2 ■ 20 F	P3.3 ■ 17 E	P4.1 ■ 15 F	P4.2 ■ 13 E	P4.3 ■ 10 D	M1.1 ■ 30 E	M1.2 ■ 26 E
M2.1 ■ 27 E	M2.2 ■ 22 E	M2.3 ■ 18 C	M3.1 ■ 13 G	M3.2 ■ 11 G	M3.3 ■ 10 C	M4.1 ■ 15 C	K1.1 ■ 35 H	K1.2 ■ 26 D	K1.3 ■ 19 D	K2.1 ■ 27 E	K2.2 ■ 22 E	K2.3 ■ 18 E	K3.1 ■ 24 E
K3.2 ■ 18 E	K3.3 ■ 15 E	K4.1 ■ 22 E	K4.2 ■ 17 E	K4.3 ■ 12 E	K4.4 ■ 11 E	K4.5 ■ 9 E	K5.1 ■ 25 E	K5.2 ■ 19 E	K5.3 ■ 15 E	N1.1 ■ 33 J	N1.2 ■ 25 J	N1.3 ■ 17 I	N2.1 ■ 46 H
N2.2 ■ 42 H	N2.3 ■ 30 H	N3.1 ■ 68 H	N3.2 ■ 40 F	N3.3 ■ 20 H	S1.1 ■ 28 F	S1.2 ■ 20 D	S1.3 ■ 11 C	S2.1 ■ 9 E	S2.2 ■ 8 B	S3.1 ■ 7 E	S3.2 ■ 6 B	S4.1 ■ 5 E	S4.2 ■ 5 B

Product	DC (mm)	DC (inch)	LCF (mm)	OAL (mm)	DCON MS (mm)
2AC01.0	1.00	0.0394	12.0	34.0	1.00
2AC01.05	1.05	0.0413	12.0	34.0	1.05
2AC01.1	1.10	0.0433	14.0	36.0	1.10
2AC01.15	1.15	0.0453	14.0	36.0	1.15
2AC01.2	1.20	0.0472	16.0	38.0	1.20
2AC01.25	1.25	0.0492	16.0	38.0	1.25
2AC01.3	1.30	0.0512	16.0	38.0	1.30
2AC01.35	1.35	0.0531	18.0	40.0	1.35
2AC01.4	1.40	0.0551	18.0	40.0	1.40
2AC01.45	1.45	0.0571	18.0	40.0	1.45
2AC01.5	1.50	0.0591	18.0	40.0	1.50
2AC01.55	1.55	0.0610	20.0	43.0	1.55
2AC01.6	1.60	0.0630	20.0	43.0	1.60
2AC01.65	1.65	0.0650	20.0	43.0	1.65
2AC01.7	1.70	0.0669	20.0	43.0	1.70
2AC01.75	1.75	0.0689	22.0	46.0	1.75
2AC01.8	1.80	0.0709	22.0	46.0	1.80
2AC01.85	1.85	0.0728	22.0	46.0	1.85
2AC01.9	1.90	0.0748	22.0	46.0	1.90
2AC01.95	1.95	0.0768	24.0	49.0	1.95
2AC02.0	2.00	0.0787	24.0	49.0	2.00
2AC02.05	2.05	0.0807	24.0	49.0	2.05
2AC02.1	2.10	0.0827	24.0	49.0	2.10
2AC02.2	2.20	0.0866	27.0	53.0	2.20
2AC02.3	2.30	0.0906	27.0	53.0	2.30
2AC02.35	2.35	0.0925	27.0	53.0	2.35

Product	DC (mm)	DC (inch)	LCF (mm)	OAL (mm)	DCON MS (mm)
2AC02.4	2.40	0.0945	30.0	57.0	2.40
2AC02.5	2.50	0.0984	30.0	57.0	2.50
2AC02.6	2.60	0.1024	30.0	57.0	2.60
2AC02.7	2.70	0.1063	33.0	61.0	2.70
2AC02.8	2.80	0.1102	33.0	61.0	2.80
2AC02.9	2.90	0.1142	33.0	61.0	2.90
2AC03.0	3.00	0.1181	33.0	61.0	3.00
2AC03.1	3.10	0.1220	36.0	65.0	3.10
2AC03.2	3.20	0.1260	36.0	65.0	3.20
2AC03.25	3.25	0.1280	36.0	65.0	3.25
2AC03.3	3.30	0.1299	36.0	65.0	3.30
2AC03.4	3.40	0.1339	39.0	70.0	3.40
2AC03.5	3.50	0.1378	39.0	70.0	3.50
2AC03.6	3.60	0.1417	39.0	70.0	3.60
2AC03.7	3.70	0.1457	39.0	70.0	3.70
2AC03.75	3.75	0.1476	39.0	70.0	3.75
2AC03.8	3.80	0.1496	43.0	75.0	3.80
2AC04.0	4.00	0.1575	43.0	75.0	4.00
2AC04.1	4.10	0.1614	43.0	75.0	4.10
2AC04.2	4.20	0.1654	43.0	75.0	4.20
2AC04.25	4.25	0.1673	43.0	75.0	4.25
2AC04.3	4.30	0.1693	47.0	80.0	4.30
2AC04.4	4.40	0.1732	47.0	80.0	4.40
2AC04.5	4.50	0.1772	47.0	80.0	4.50
2AC04.7	4.70	0.1850	47.0	80.0	4.70
2AC04.8	4.80	0.1890	52.0	86.0	4.80

Product	DC	DC	LCF	OAL	DCON MS
	(mm)	(inch)	(mm)	(mm)	(mm)
2AC05.0	5.00	0.1969	52.0	86.0	5.00
2AC05.1	5.10	0.2008	52.0	86.0	5.10
2AC05.2	5.20	0.2047	52.0	86.0	5.20
2AC05.25	5.25	0.2067	52.0	86.0	5.25
2AC05.3	5.30	0.2087	52.0	86.0	5.30
2AC05.5	5.50	0.2165	57.0	93.0	5.50
2AC05.6	5.60	0.2205	57.0	93.0	5.60
2AC05.7	5.70	0.2244	57.0	93.0	5.70
2AC05.9	5.90	0.2323	57.0	93.0	5.90
2AC06.0	6.00	0.2362	57.0	93.0	6.00
2AC06.1	6.10	0.2402	63.0	101.0	6.10
2AC06.2	6.20	0.2441	63.0	101.0	6.20
2AC06.3	6.30	0.2480	63.0	101.0	6.30
2AC06.4	6.40	0.2520	63.0	101.0	6.40
2AC06.5	6.50	0.2559	63.0	101.0	6.50
2AC06.6	6.60	0.2598	63.0	101.0	6.60
2AC06.7	6.70	0.2638	63.0	101.0	6.70
2AC06.8	6.80	0.2677	69.0	109.0	6.80
2AC06.9	6.90	0.2717	69.0	109.0	6.90
2AC07.0	7.00	0.2756	69.0	109.0	7.00
2AC07.1	7.10	0.2795	69.0	109.0	7.10
2AC07.2	7.20	0.2835	69.0	109.0	7.20
2AC07.25	7.25	0.2854	69.0	109.0	7.25
2AC07.3	7.30	0.2874	69.0	109.0	7.30
2AC07.5	7.50	0.2953	69.0	109.0	7.50
2AC07.8	7.80	0.3071	75.0	117.0	7.80
2AC07.9	7.90	0.3110	75.0	117.0	7.90

Product	DC	DC	LCF	OAL	DCON MS
	(mm)	(inch)	(mm)	(mm)	(mm)
2AC08.0	8.00	0.3150	75.0	117.0	8.00
2AC08.2	8.20	0.3228	75.0	117.0	8.20
2AC08.4	8.40	0.3307	75.0	117.0	8.40
2AC08.5	8.50	0.3346	75.0	117.0	8.50
2AC08.8	8.80	0.3465	81.0	125.0	8.80
2AC08.9	8.90	0.3504	81.0	125.0	8.90
2AC09.0	9.00	0.3543	81.0	125.0	9.00
2AC09.1	9.10	0.3583	81.0	125.0	9.10
2AC09.2	9.20	0.3622	81.0	125.0	9.20
2AC09.3	9.30	0.3661	81.0	125.0	9.30
2AC09.4	9.40	0.3701	81.0	125.0	9.40
2AC09.5	9.50	0.3740	81.0	125.0	9.50
2AC09.6	9.60	0.3780	87.0	133.0	9.60
2AC09.7	9.70	0.3819	87.0	133.0	9.70
2AC09.8	9.80	0.3858	87.0	133.0	9.80
2AC010.0	10.00	0.3937	87.0	133.0	10.00
2AC010.2	10.20	0.4016	87.0	133.0	10.20
2AC010.5	10.50	0.4134	87.0	133.0	10.50
2AC010.8	10.80	0.4252	94.0	142.0	10.80
2AC011.0	11.00	0.4331	94.0	142.0	11.00
2AC011.2	11.20	0.4409	94.0	142.0	11.20
2AC011.5	11.50	0.4528	94.0	142.0	11.50
2AC011.8	11.80	0.4646	94.0	142.0	11.80
2AC012.0	12.00	0.4724	101.0	151.0	12.00
2AC012.2	12.20	0.4803	101.0	151.0	12.20
2AC012.5	12.50	0.4921	101.0	151.0	12.50
2AC013.0	13.00	0.5118	101.0	151.0	13.00

Code de matériau du corps (BMC)	HSS	HSS	HSS	HSS	HSS	HSS	HSS	HSS	HSS	HSS-E	HSS
Revêtement	Bright	Bright	Bright	Bright	Bright	Bright	Bright	Bright	TiAlN	Bright	Bright
Groupe standard de base (BSG)	DIN 334C	DIN 335C	DORMER	DIN 335A	ANSI	DIN 335C	DIN 335C	DIN 335C	DIN 335C	DORMER	DORMER
Sens (direction de coupe)	R	R	R	R	R	R	R	R	R	R	R
Queue											
Angle d'application	60°	82°	90°	90°		90°	90°	90°	90°	90°	90°



Code de famille de produits	G135	G154	G129	G132	B690	G142	G136	G106	G506	G107	G600	G236
Plage de diamètres de coupe PSF	6.30 - 25.00	6.30 - 25.00	6.00 - 31.50	8.00 - 20.00	1/4 - 1"	5.00 - 31.00	4.30 - 31.00	6.30 - 50.00	6.30 - 50.00	6.30 - 20.50	6.30 - 25.00	Set
	60	61	62	63	64	65	66	67	68	69	70	71

P	P1	■	■	■	■	■	■	■	■	■	■	■
	P2	■	■	■	■	■	■	■	■	■	■	■
	P3	■	■	■	■	■	■	■	■	■	■	■
	P4	■	■	■	■	■	■	■	■	■	■	■
M	M1	■	■	■	■	■	■	■	■	■	■	■
	M2	■	■	■	■	■	■	■	■	■	■	■
	M3				■	■	■					
	M4				■	■	■					
K	K1	■	■	■	■	■	■	■	■	■	■	■
	K2	■	■	■	■	■	■	■	■	■	■	■
	K3	■	■	■	■	■	■	■	■	■	■	■
	K4				■	■				■	■	
	K5	■	■		■	■	■	■	■	■	■	■
N	N1	■	■	■	■	■	■	■	■	■	■	■
	N2	■	■	■	■	■	■	■	■	■	■	■
	N3	■	■	■	■	■	■	■	■	■	■	■
	N4	■	■	■	■	■	■	■	■	■	■	■
	N5											
S	S1											
	S2											
	S3											
	S4											
H	H1											
	H2											
	H3											
	H4											

G135

DORMER



Fraise en HSS à ébavurer et à chanfreiner à 60° à queue cylindrique, finition brillante

Fraise à chanfreiner à 60° pour les trous de fixation spéciaux et pour éliminer les bavures des trous percés dans des diamètres allant jusqu'à 25,0 mm. S'utilise aussi bien sur machines qu'à la main. Convient pour chanfreiner les trous dans de nombreux matériaux.

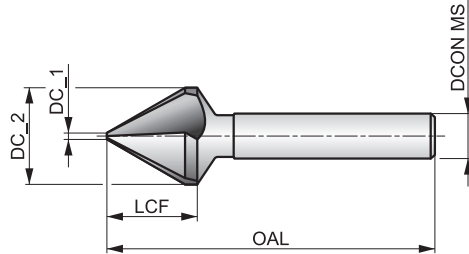

HSS	Bright	DIN 334C
R	60°	

Adéquation du groupe de matériaux de la pièce, valeurs de départ pour la vitesse de coupe (m/min) et code Alpha d'avance. Les tableaux d'avances par tour se trouvent à partir de la page 280.

P1.1 ■ 23 E	P1.2 ■ 26 E	P1.3 ■ 27 E	P2.1 ■ 20 E	P2.2 ■ 18 D	P2.3 ▣ 16 B	P3.1 ■ 16 D	P3.2 ▣ 13 D	P3.3 ▣ 11 B	P4.1 ■ 10 D	P4.2 ▣ 8 B	M1.1 ▣ 8 C	M1.2 ▣ 16 C	M2.1 ▣ 17 C
M2.2 ▣ 16 C	K1.1 ▣ 20 F	K1.2 ▣ 15 D	K2.1 ▣ 21 C	K2.2 ▣ 17 C	K3.1 ▣ 18 C	K3.2 ▣ 14 C	K5.1 ▣ 19 C	K5.2 ▣ 15 C	N1.1 ▣ 40 G	N1.2 ■ 30 G	N1.3 ▣ 20 F	N2.1 ■ 20 F	N2.2 ▣ 18 F
N3.1 ■ 21 F	N3.2 ■ 12 F	N3.3 ▣ 16 D	N4.1 ▣ 40 G	N4.2 ▣ 35 G									

DCON MS tolérance h9.

Product	DC_2 (mm)	DC_1 (mm)	LCF (mm)	OAL (mm)	DCON MS (mm)	NOF
G1356.3	6.30	1.60	6.8	45.0	5.00	3
G1358.0	8.00	2.00	8.5	50.0	6.00	3
G13510.0	10.00	2.50	7.6	50.0	6.00	3
G13512.5	12.50	3.20	11.7	56.0	8.00	3
G13516.0	16.00	4.00	14.5	63.0	10.00	3
G13520.0	20.00	5.00	17.5	67.0	10.00	3
G13525.0	25.00	6.30	20.5	71.0	10.00	3

G154



Fraise en HSS à ébavurer et à chanfreiner à 82° à queue cylindrique, finition brillante

Fraise à chanfreiner à 82° pour les vis à tête plate et pour chanfreiner les trous. Fraise polyvalente qui peut être utilisée aussi bien à la main qu'en machine. Convient pour chanfreiner les trous dans de nombreux matériaux.

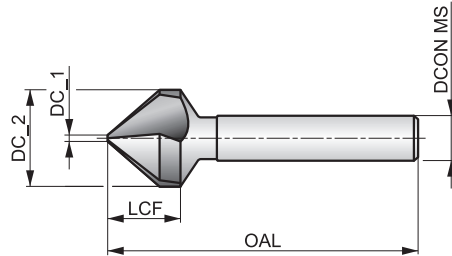

HSS	Bright	DIN 335C
R	82°	

Adéquation du groupe de matériaux de la pièce, valeurs de départ pour la vitesse de coupe (m/min) et code Alpha d'avance. Les tableaux d'avances par tour se trouvent à partir de la page 280.

P1.1 ■ 23 E	P1.2 ■ 26 E	P1.3 ■ 27 E	P2.1 ■ 20 E	P2.2 ■ 18 D	P2.3 ▣ 16 B	P3.1 ■ 16 D	P3.2 ■ 13 D	P3.3 ▣ 11 B	P4.1 ■ 10 D	P4.2 ▣ 8 B	M1.1 ▣ 8 C	M1.2 ▣ 16 C	M2.1 ▣ 17 C
M2.2 ▣ 16 C	K1.1 ▣ 20 F	K1.2 ▣ 15 D	K2.1 ▣ 21 C	K2.2 ▣ 17 C	K3.1 ▣ 18 C	K3.2 ▣ 14 C	K5.1 ▣ 14 C	K5.2 ▣ 10 C	N1.1 ▣ 40 G	N1.2 ■ 30 G	N1.3 ▣ 20 F	N2.1 ■ 20 F	N2.2 ▣ 18 F
N3.1 ■ 21 F	N3.2 ■ 12 F	N3.3 ▣ 16 D	N4.1 ▣ 40 G	N4.2 ▣ 35 G									

DCON MS tolérance h9.

Product	DC_2 (mm)	DC_1 (mm)	LCF (mm)	OAL (mm)	DCON MS (mm)	NOF
G1546.3	6.30	1.50	5.5	45.0	5.00	3
G1548.3	8.30	2.00	6.5	50.0	6.00	3
G15410.4	10.40	2.50	7.6	50.0	6.00	3
G15412.4	12.40	2.80	8.5	56.0	8.00	3
G15416.5	16.50	3.20	10.5	60.0	10.00	3
G15420.5	20.50	3.50	13.0	63.0	10.00	3
G15425.0	25.00	3.80	15.5	67.0	10.00	3

G129

DORMER



Fraise en HSS à ébavurer et à chanfreiner à 90° à une dent et à queue cylindrique, finition brillante
 Fraise à chanfreiner à 90° avec une finition brillante pour chanfreiner et pour éliminer les bavures des trous percés. La conception à une seule dent réduit les vibrations et le broutage pour une opération de chanfreinage en douceur. Convient pour chanfreiner les trous dans les aciers doux et les matériaux non ferreux de résistance moyenne, tels que l'aluminium.

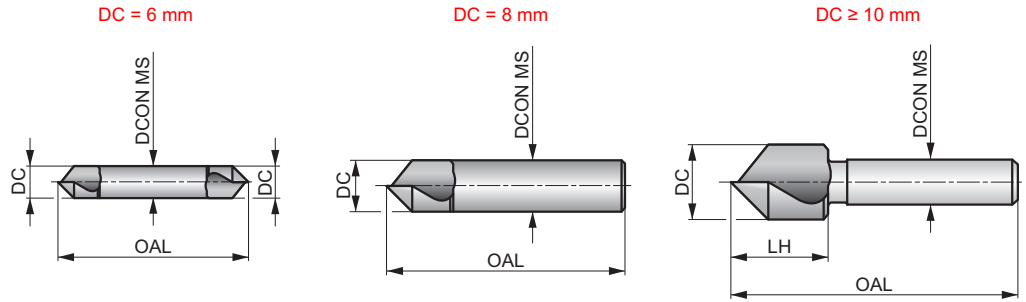

HSS	Bright	DORMER
R	90°	

Adéquation du groupe de matériaux de la pièce, valeurs de départ pour la vitesse de coupe (m/min) et code Alpha d'avance. Les tableaux d'avances par tour se trouvent à partir de la page 280.

P1.1 ■ 21 D	P1.2 ■ 24 D	P1.3 ■ 25 D	P2.1 ■ 18 D	P2.2 ■ 16 C	P2.3 ▣ 14 A	P3.1 ■ 13 B	P3.2 ▣ 11 B	M1.1 ▣ 8 B	M1.2 ▣ 6 B	M2.1 ▣ 7 B	K1.1 ▣ 18 D	K1.2 ▣ 13 C	K2.1 ▣ 19 A
K2.2 ▣ 15 A	K3.1 ▣ 16 A	K3.2 ▣ 12 A	N1.1 ■ 34 D	N1.2 ■ 25 D	N1.3 ▣ 16 C	N2.1 ▣ 16 C	N2.2 ▣ 14 C	N3.1 ■ 17 C	N3.2 ■ 9 C	N3.3 ▣ 5 B	N4.1 ▣ 35 D	N4.2 ▣ 30 D	

DCON MS tolérance h9.

Product	DC (mm)	LH (mm)	OAL (mm)	DCON MS (mm)	NOF
G1296.0	6.00	–	45.0	6.00	1
G1298.0	8.00	–	50.0	8.00	1
G12910.0	10.00	17.0	49.0	8.00	1
G12912.5	12.50	17.0	49.0	8.00	1
G12916.0	16.00	20.0	56.0	10.00	1
G12920.0	20.00	24.0	60.0	10.00	1
G12925.0	25.00	25.0	75.0	12.00	1
G12931.5	31.50	29.0	80.0	12.00	1

G132

DORMER



Fraise en HSS à ébavurer et à chanfreiner à 90° à queue cylindrique, multi-dents, finition brillante
 Fraise à 90° conçue pour les trous de fixation standards et réaliser des opérations d'ébavurage. Le grand nombre de dents permet de réduire les vibrations pour une opération de chanfreinage en douceur. Fraise polyvalente adaptée aussi bien pour les applications électro-portatives que sur machines. Elle convient pour le chanfreinage de trous dans de nombreux matériaux.

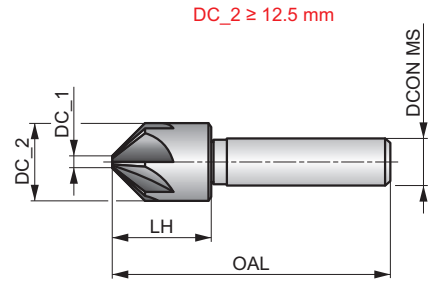
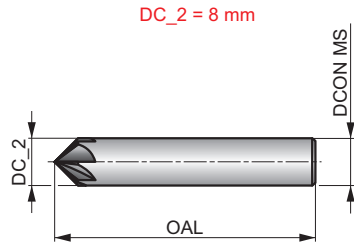

HSS	Bright	DIN 335A
R		90°

Adéquation du groupe de matériaux de la pièce, valeurs de départ pour la vitesse de coupe (m/min) et code Alpha d'avance. Les tableaux d'avances par tour se trouvent à partir de la page 280.

P2.2 ■ 18 E	P2.3 ■ 16 D	P3.2 ■ 13 D	P3.3 ■ 11 B	P4.1 ■ 10 D	P4.2 ■ 8 C	P4.3 ■ 7 B	M3.3 ■ 3 A	M4.1 ■ 4 A	K1.1 ■ 20 F	K1.2 ■ 15 D	K1.3 ■ 11 D	K2.2 ■ 17 C	K2.3 ■ 14 D
K3.1 ■ 18 E	K3.2 ■ 14 E	K3.3 ■ 11 D	K4.1 ■ 17 C	K4.2 ■ 13 C	K5.1 ■ 19	K5.2 ■ 15	K5.3 ■ 11 D	N1.3 ■ 20 F	N2.3 ■ 13 F	N3.2 ■ 12 F	N4.3 ■ 5 G		

DCON MS tolérance h9.

Product	DC_2 (mm)	DC_1 (mm)	LH (mm)	OAL (mm)	DCON MS (mm)	NOF
G1328.0	8.00	—	—	48.0	8.00	5
G13212.5	12.50	2.00	15.5	48.0	8.00	5
G13216.0	16.00	3.20	19.5	56.0	10.00	7
G13220.0	20.00	5.00	23.0	60.0	10.00	7

B690



Alésoir en HSS à queue cylindrique pour trous de centre et trous fraisés, angles 60°, 82°, 90° ou 100°
 Principalement utilisé pour l'alésage de trous de centre, et le chanfreinage des têtes de vis et de rivets. Disponibles avec des angles de 60°, 82°, 90° ou 100°. Le nombre inégal de goujures favorise la finition en éliminant le broutage tout en améliorant la précision.

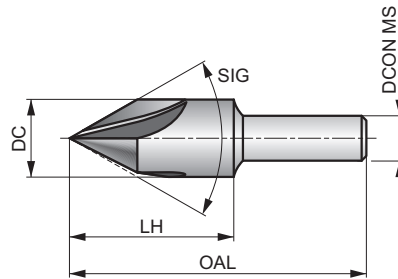

HSS	Bright	ANSI
R	Reamer	60-100°

Adéquation du groupe de matériaux de la pièce, valeurs de départ pour la vitesse de coupe (m/min) et code Alpha d'avance. Les tableaux d'avances par tour se trouvent à partir de la page 280.

P1.1 ■ 21 D	P1.2 ■ 24 D	P1.3 ■ 25 D	P2.1 ■ 18 D	P2.2 ■ 16 C	P2.3 ■ 14 A	P3.1 ■ 13 B	P3.2 ■ 11 B	M1.1 ■ 8 B	M1.2 ■ 6 B	M2.1 ■ 7 B	K1.1 ■ 18 D	K1.2 ■ 13 C	K2.1 ■ 19 A
K2.2 ■ 15 A	K3.1 ■ 16 A	K3.2 ■ 12 A	N1.1 ■ 34 D	N1.2 ■ 25 D	N1.3 ■ 16 C	N2.1 ■ 16 C	N2.2 ■ 14 C	N3.1 ■ 17 C	N3.2 ■ 9 C	N3.3 ■ 5 B	N4.1 ■ 35 D	N4.2 ■ 30 D	

Product	DC (inch)	DC (inch)	SIG (°)	DCON MS (inch)	OAL (inch)	NOF
B6901/4X60	1/4	0.2500	60	3/16	1.1/2	3
B6901/4X82	1/4	0.2500	82	3/16	1.1/2	3
B6901/4X90	1/4	0.2500	90	3/16	1.1/2	3
B6901/4X100	1/4	0.2500	100	3/16	1.1/2	3
B6903/8X60	3/8	0.3750	60	1/4	1.3/4	3
B6903/8X82	3/8	0.3750	82	1/4	1.3/4	3
B6903/8X90	3/8	0.3750	90	1/4	1.3/4	3
B6903/8X100	3/8	0.3750	100	1/4	1.3/4	3
B6901/2X60	1/2	0.5000	60	3/8	2"	3
B6901/2X82	1/2	0.5000	82	3/8	2"	3
B6901/2X90	1/2	0.5000	90	3/8	2"	3
B6901/2X100	1/2	0.5000	100	3/8	2"	3

Product	DC (inch)	DC (inch)	SIG (°)	DCON MS (inch)	OAL (inch)	NOF
B6905/8X60	5/8	0.6250	60	3/8	2.1/4	3
B6905/8X82	5/8	0.6250	82	3/8	2.1/4	3
B6905/8X90	5/8	0.6250	90	3/8	2.1/4	3
B6905/8X100	5/8	0.6250	100	3/8	2.1/4	3
B6903/4X60	3/4	0.7500	60	1/2	2.5/8	3
B6903/4X82	3/4	0.7500	82	1/2	2.5/8	3
B6903/4X90	3/4	0.7500	90	1/2	2.5/8	3
B6903/4X100	3/4	0.7500	100	1/2	2.5/8	3
B6901X60	1"	1.0000	60	1/2	3"	3
B6901X82	1"	1.0000	82	1/2	3"	3
B6901X90	1"	1.0000	90	1/2	3"	3
B6901X100	1"	1.0000	100	1/2	3"	3

G142

DORMER



Fraise en HSS à ébavurer et à chanfreiner à 90° à queue cylindrique, finition brillante, acier inoxydable
 Fraise à chanfreiner à 90° conçue pour les trous de fixation standards et les opérations d'ébavurage. Sa géométrie positive prononcée permet d'améliorer les performances lors de l'usinage de matériaux collants, tels que les aciers inoxydables et les matériaux non ferreux. Elle peut être utilisée aussi bien pour les applications électro-portatives que sur machines.

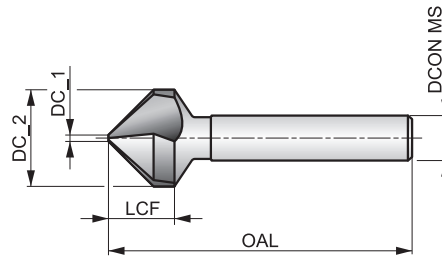

HSS	Bright	DIN 335C
R	90°	

Adéquation du groupe de matériaux de la pièce, valeurs de départ pour la vitesse de coupe (m/min) et code Alpha d'avance. Les tableaux d'avances par tour se trouvent à partir de la page 280.

P1.1 ■ 23 E	P1.2 ■ 26 E	P1.3 ■ 27 E	P2.1 ■ 20 E	P2.2 ■ 18 D	P2.3 ▧ 16 B	P3.1 ■ 16 D	P3.2 ■ 13 D	P3.3 ▧ 11 B	P4.1 ■ 10 D	P4.2 ▧ 8 B	M1.1 ■ 11 C	M1.2 ■ 9 C	M2.1 ■ 10 C
M2.2 ▧ 8 C	M3.1 ■ 7 B	M3.2 ▧ 6 B	M4.1 ▧ 4 A	N1.1 ■ 40 G	N1.2 ■ 30 G	N1.3 ▧ 20 F	N2.1 ▧ 20 F	N2.2 ▧ 18 F	N2.3 ▧ 20 F	N3.1 ■ 34 F	N3.2 ■ 20 F	N3.3 ■ 10 D	N4.1 ■ 40 G
N4.2 ■ 35 G													

DCON MS tolérance h9.

Product	DC_2 (mm)	DC_1 (mm)	LCF (mm)	OAL (mm)	DCON MS (mm)	NOF
G1425.0	5.00	1.50	4.5	40.0	4.00	3
G1426.3	6.30	1.50	5.5	45.0	5.00	3
G1428.0	8.00	2.00	6.1	50.0	6.00	3
G1428.3	8.30	2.00	6.5	50.0	6.00	3
G14210.0	10.00	2.50	7.6	50.0	6.00	3
G14210.4	10.40	2.50	7.6	50.0	6.00	3
G14212.4	12.40	2.80	8.5	56.0	8.00	3
G14215.0	15.00	3.20	9.5	60.0	10.00	3
G14216.5	16.50	3.20	10.5	60.0	10.00	3
G14220.5	20.50	3.50	13.0	63.0	10.00	3
G14223.0	23.00	3.80	13.7	67.0	10.00	3
G14225.0	25.00	3.80	15.5	67.0	10.00	3
G14231.0	31.00	4.20	18.5	71.0	12.00	3

G136

DORMER



Fraise en HSS à ébavurer et à chanfreiner à 90° à queue cylindrique, finition brillante

Fraise à chanfreiner à 90° conçue pour les trous de fixation standards et réaliser des opérations d'ébavurage. Sa queue réduite permet de réaliser des chanfreins d'un plus grand diamètre. Fraise polyvalente adaptée aussi bien aux applications électro-portatives que sur machines dans de très nombreux matériaux

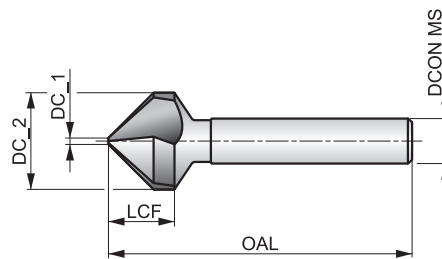

HSS	Bright	DIN 335C
R	90°	

Adéquation du groupe de matériaux de la pièce, valeurs de départ pour la vitesse de coupe (m/min) et code Alpha d'avance. Les tableaux d'avances par tour se trouvent à partir de la page 280.

P1.1 ■ 23 E	P1.2 ■ 26 E	P1.3 ■ 27 E	P2.1 ■ 20 E	P2.2 ■ 18 D	P2.3 ■ 16 B	P3.1 ■ 16 D	P3.2 ■ 13 D	P3.3 ■ 11 B	P4.1 ■ 10 D	P4.2 ■ 8 B	M1.1 ■ 8 C	M1.2 ■ 6 C	M2.1 ■ 7 C
M2.2 ■ 6 C	K1.1 ■ 20 F	K1.2 ■ 15 D	K2.1 ■ 21 C	K2.2 ■ 17 C	K3.1 ■ 18 C	K3.2 ■ 14 C	K5.1 ■ 19 C	K5.2 ■ 15 C	N1.1 ■ 40 G	N1.2 ■ 30 G	N1.3 ■ 20 F	N2.1 ■ 20 F	N2.2 ■ 18 F
N3.1 ■ 21 F	N3.2 ■ 12 F	N3.3 ■ 16 D	N4.1 ■ 40 G	N4.2 ■ 35 G									

DCON MS tolérance h9.
Les produits de cette série sont également disponibles en coffret. Voir G236.

Product	DC_2	DC_1	LCF	OAL	DCON MS	NOF
	(mm)	(mm)	(mm)	(mm)	(mm)	
G1364.3	4.30	1.30	4.0	40.0	4.00	3
G1365.0	5.00	1.50	4.5	40.0	4.00	3
G1365.3	5.30	1.50	4.5	40.0	4.00	3
G1365.8	5.80	1.50	5.0	45.0	5.00	3
G1366.0	6.00	1.50	5.0	45.0	5.00	3
G1366.3	6.30	1.50	5.5	45.0	5.00	3
G1367.0	7.00	1.80	5.5	50.0	6.00	3
G1367.3	7.30	1.80	6.1	50.0	6.00	3
G1368.0	8.00	2.00	6.1	50.0	6.00	3
G1368.3	8.30	2.00	6.5	50.0	6.00	3
G1369.4	9.40	2.20	7.2	50.0	6.00	3
G13610.0	10.00	2.50	7.6	50.0	6.00	3
G13610.4	10.40	2.50	7.6	50.0	6.00	3

Product	DC_2	DC_1	LCF	OAL	DCON MS	NOF
	(mm)	(mm)	(mm)	(mm)	(mm)	
G13611.5	11.50	2.80	8.0	56.0	8.00	3
G13612.4	12.40	2.80	8.5	56.0	8.00	3
G13613.4	13.40	2.90	9.0	56.0	8.00	3
G13615.0	15.00	3.20	9.5	60.0	10.00	3
G13616.5	16.50	3.20	10.5	60.0	10.00	3
G13619.0	19.00	3.50	11.7	63.0	10.00	3
G13620.5	20.50	3.50	13.0	63.0	10.00	3
G13623.0	23.00	3.80	13.7	67.0	10.00	3
G13625.0	25.00	3.80	15.5	67.0	10.00	3
G13626.0	26.00	3.80	15.5	67.0	10.00	3
G13628.0	28.00	4.00	16.5	71.0	12.00	3
G13630.0	30.00	4.20	18.5	71.0	12.00	3
G13631.0	31.00	4.20	18.5	71.0	12.00	3

G106



Fraise en HSS à ébavurer et à chanfreiner à 90° à queue cylindrique à 3 méplats, finition brillante

Fraise chanfreiner à 90° conçue pour les trous de fixation standards et réaliser des opérations d'ébavurage. La queue à trois méplats rectifiés permet une meilleure tenue dans les mandrins à trois mors, en particulier lors de l'utilisation d'outils électro-portatifs. Convient pour chanfreiner dans de très nombreux matériaux.

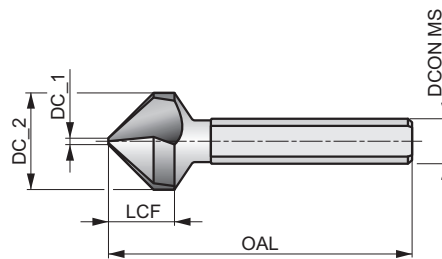

HSS	Bright	DIN 335C
R		90°

Adéquation du groupe de matériaux de la pièce, valeurs de départ pour la vitesse de coupe (m/min) et code Alpha d'avance. Les tableaux d'avances par tour se trouvent à partir de la page 280.

P1.1 ■ 23 E	P1.2 ■ 26 E	P1.3 ■ 27 E	P2.1 ■ 20 E	P2.2 ■ 18 D	P2.3 ▣ 16 B	P3.1 ■ 16 D	P3.2 ■ 13 D	P3.3 ▣ 11 B	P4.1 ■ 10 D	P4.2 ▣ 8 B	M1.1 ▣ 8 C	M1.2 ▣ 16 C	M2.1 ▣ 17 C
M2.2 ▣ 6 C	K1.1 ■ 20 F	K1.2 ■ 15 D	K2.1 ▣ 21 C	K2.2 ▣ 17 C	K3.1 ▣ 18 C	K3.2 ▣ 14 C	K5.1 ▣ 19 C	K5.2 ▣ 15 C	N1.1 ▣ 40 G	N1.2 ■ 30 G	N1.3 ▣ 20 F	N2.1 ▣ 20 F	N2.2 ▣ 18 F
N3.1 ■ 21 F	N3.2 ▣ 12 F	N3.3 ▣ 16 D	N4.1 ▣ 40 G	N4.2 ▣ 35 G									

DCON MS tolérance h9.

Les produits de cette série sont également disponibles en coffret. Voir G236.

Product	DC_2 (mm)	DC_1 (mm)	LCF (mm)	OAL (mm)	DCON MS (mm)	NOF
G1066.3	6.30	1.50	5.6	45.0	5.00	3
G1068.3	8.30	2.00	6.9	50.0	6.00	3
G10610.4	10.40	2.50	7.8	50.0	6.00	3
G10612.4	12.40	2.80	8.6	56.0	8.00	3
G10616.5	16.50	3.20	11.1	60.0	10.00	3
G10620.5	20.50	3.50	12.9	63.0	10.00	3
G10625.0	25.00	3.80	15.7	67.0	10.00	3
G10631.0	31.00	4.20	18.5	71.0	12.00	3
G10634.0	34.00	4.50	19.0	103.0	16.00	3
G10637.0	37.00	4.50	21.2	118.0	16.00	3
G10640.0	40.00	4.50	20.0	118.0	16.00	3
G10650.0	50.00	5.00	23.6	126.0	16.00	3

G506

DORMER

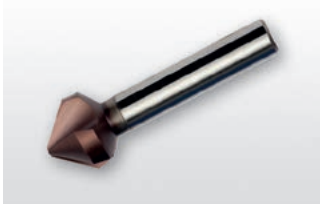

Fraise en HSS à ébavurer et à chanfreiner à 90° à queue cylindrique à 3 méplats, revêtement TiAIN
 Fraise à chanfreiner à 90° conçue pour chanfreiner les trous de fixation standards et réaliser des opérations d'ébavurage. La queue à trois méplats rectifiés permet une meilleure tenue dans les mandrins à trois mors, en particulier lors de l'utilisation d'outils électro-portatifs. Son revêtement TiAIN prolonge la durée de vie de l'outil. Convient pour chanfreiner dans de très nombreux matériaux.

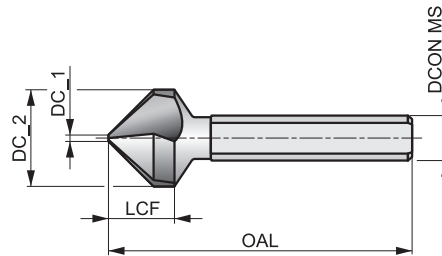

HSS	TiAIN	DIN 335C
R		90°

Adéquation du groupe de matériaux de la pièce, valeurs de départ pour la vitesse de coupe (m/min) et code Alpha d'avance. Les tableaux d'avances par tour se trouvent à partir de la page 280.

P1.1 ■ 40 E	P1.2 ■ 45 E	P1.3 ■ 46 E	P2.1 ■ 34 E	P2.2 ■ 30 D	P2.3 ■ 27 B	P3.1 ■ 28 D	P3.2 ■ 22 D	P3.3 ■ 19 B	P4.1 ■ 16 D	P4.2 ■ 14 B	P4.3 ▣ 11 B	M1.1 ▣ 11 C	M1.2 ▣ 9 C
M2.1 ▣ 10 C	M2.2 ▣ 9 C	M2.3 ▣ 8 B	K1.1 ■ 41 F	K1.2 ■ 30 D	K1.3 ▣ 23 D	K2.1 ■ 42 C	K2.2 ■ 34 C	K2.3 ▣ 27 C	K3.1 ■ 37 C	K3.2 ■ 28 C	K3.3 ▣ 23 C	K4.1 ▣ 34 C	K4.2 ▣ 26 C
K4.3 ▣ 19 C	K5.1 ■ 39 C	K5.2 ■ 29 C	K5.3 ▣ 23 C	N1.1 ▣ 60 G	N1.2 ▣ 45 G	N1.3 ■ 30 F	N2.1 ■ 30 F	N2.2 ■ 27 F	N2.3 ■ 19 F	N3.1 ■ 32 F	N3.2 ■ 18 F	N3.3 ▣ 19 D	N4.1 ▣ 62 G
N4.2 ▣ 55 G													

DCON MS tolérance h9.
 Les produits de cette série sont également disponibles en coffret. Voir G236.

Product	DC_2 (mm)	DC_1 (mm)	LCF (mm)	OAL (mm)	DCON MS (mm)	NOF
G5066.3	6.30	1.50	5.6	45.0	5.00	3
G5068.3	8.30	2.00	6.9	50.0	6.00	3
G50610.4	10.40	2.50	7.8	50.0	6.00	3
G50612.4	12.40	2.80	8.6	56.0	8.00	3
G50616.5	16.50	3.20	11.1	60.0	10.00	3
G50620.5	20.50	3.50	12.9	63.0	10.00	3
G50625.0	25.00	3.80	15.7	67.0	10.00	3
G50631.0	31.00	4.20	18.5	71.0	12.00	3
G50637.0	37.00	4.50	21.2	118.0	16.00	3
G50640.0	40.00	4.50	20.0	118.0	16.00	3
G50650.0	50.00	5.00	23.6	126.0	16.00	3

G107



Fraise en HSS-E à ébavurer et à chanfreiner à 90° à queue hexagonale, finition brillante

Fraise polyvalente avec une queue hexagonale qui facilite la prise en main avec les adaptateurs de tournevis électriques. La fraise à 90° produit des chanfreins pour les trous de fixation standards et élimine les bavures des trous percés. Convient pour chanfreiner les trous dans de nombreux matériaux.

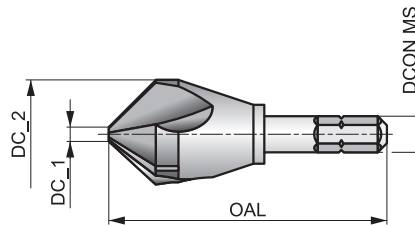

HSS-E	Bright	DORMER
R		90°

Adéquation du groupe de matériaux de la pièce, valeurs de départ pour la vitesse de coupe (m/min) et code Alpha d'avance. Les tableaux d'avances par tour se trouvent à partir de la page 280.

P1.1 ■ 23 E	P1.2 ■ 26 E	P1.3 ■ 27 E	P2.1 ■ 20 E	P2.2 ■ 18 D	P2.3 ▣ 16 B	P3.1 ■ 16 D	P3.2 ■ 13 D	P3.3 ▣ 11 B	P4.1 ■ 10 D	P4.2 ▣ 8 B	M1.1 ▣ 11 C	M1.2 ▣ 9 C	M2.1 ▣ 10 C
M2.2 ▣ 9 C	M2.3 ▣ 8 B	K1.1 ■ 20 F	K1.2 ▣ 15 D	K2.1 ■ 21 C	K2.2 ▣ 17 C	K3.1 ■ 18 C	K3.2 ▣ 14 C	K4.1 ▣ 15 C	K5.1 ■ 19 C	K5.2 ▣ 15 C	N1.1 ▣ 40 G	N1.2 ■ 30 G	N1.3 ▣ 20 F
N2.1 ▣ 20 F	N2.2 ▣ 18 F	N2.3 ▣ 20 F	N3.1 ■ 21 F	N3.2 ▣ 12 F	N3.3 ▣ 6 D	N4.1 ▣ 40 G	N4.2 ▣ 35 G						

Queue hex. 6.35; 1/4"; DIN 74.

Product	DC_2 (mm)	DC_1 (mm)	OAL (mm)	DCON MS (inch)	CZC MS	NOF
G1076.3	6.30	1.50	50.0	1/4"	M2-M3	3
G10710.4	10.40	2.50	50.0	1/4"	M5	3
G10712.4	12.40	2.80	50.0	1/4"	M6	3
G10716.5	16.50	3.20	50.0	1/4"	M8	3
G10720.5	20.50	3.50	50.0	1/4"	M10	3

G600



Fraise en HSS à ébavurer et à chanfreiner à 90° extra-longue à queue cylindrique, finition brillante
 Fraise à chanfreiner à 90° avec une queue longue permettant de chanfreiner les trous dans les zones difficiles à atteindre. Permet de réaliser des chanfreins à 90° dans des trous de fixation standards et de nettoyer les bavures des trous percés. Convient pour chanfreiner les trous dans de nombreux matériaux.

HSS	Bright	DORMER
R		90°

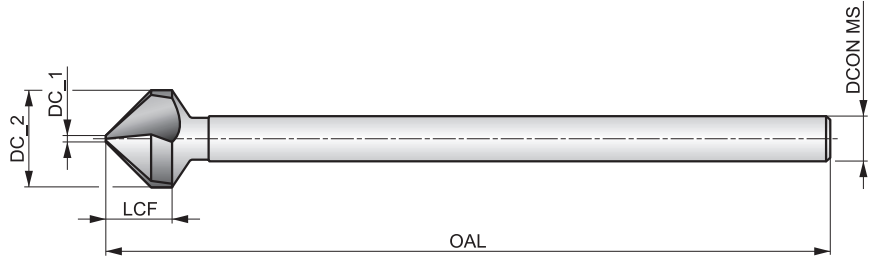

Adéquation du groupe de matériaux de la pièce, valeurs de départ pour la vitesse de coupe (m/min) et code Alpha d'avance. Les tableaux d'avances par tour se trouvent à partir de la page 280.

P1.1 ■ 20 E	P1.2 ■ 22 E	P1.3 ■ 23 E	P2.1 ■ 17 E	P2.2 ■ 15 D	P2.3 ▣ 13 B	P3.1 ■ 12 D	P3.2 ■ 9 D	P3.3 ▣ 8 B	P4.1 ■ 7 D	P4.2 ▣ 6 B	M1.1 ▣ 8 C	M1.2 ▣ 6 C	M2.1 ▣ 7 C
M2.2 ▣ 6 C	K1.1 ■ 17 E	K1.2 ▣ 12 C	K2.1 ▣ 18 B	K2.2 ▣ 14 B	K3.1 ▣ 15 B	K3.2 ▣ 11 B	K5.1 ▣ 16 B	K5.2 ▣ 12 B	N1.1 ▣ 35 G	N1.2 ▣ 25 G	N1.3 ▣ 15 F	N2.1 ▣ 15 F	N2.2 ▣ 13 F
N3.1 ■ 16 E	N3.2 ▣ 10 E	N3.3 ▣ 5 C											

DCON MS tolérance h9.

Product	DC_2 (mm)	DC_1 (mm)	LCF (mm)	OAL (mm)	DCON MS (mm)	NOF
G6006.3	6.30	1.30	5.6	154.0	5.00	3
G6008.3	8.30	1.80	6.9	155.0	6.00	3
G60010.4	10.40	2.20	7.8	157.0	6.00	3
G60012.4	12.40	2.50	8.6	158.0	8.00	3
G60015.0	15.00	2.80	10.3	159.0	10.00	3
G60016.5	16.50	2.80	11.1	161.0	10.00	3
G60020.5	20.50	3.00	12.9	164.0	10.00	3
G60025.0	25.00	3.20	15.7	168.0	10.00	3



G236

DORMER



Coffret de fraises à éburer et à chanfreiner dans un boîtier cylindrique en plastique

Coffrets contenant une variété de différentes tailles de fraises à chanfreiner à 90°. Il existe 5 jeux différents disponibles remplis soit de G106, G136 ou G560. Convient pour de nombreux matériaux.



A=Types dans le coffret, B=Quantité dans le coffret, C=Diamètres dans le coffret.

Product	Nr.	A	B	C
G2361	1	G136	6	6.30 mm, 8.30 mm, 10.40 mm, 12.40 mm, 16.50 mm, 20.50 mm
G2362	2	G136	4	6.30 mm, 10.40 mm, 16.50 mm, 20.50 mm
G2363	3	G560	6	6.30 mm, 8.30 mm, 10.40 mm, 12.40 mm, 16.50 mm, 20.50 mm
G2364	4	G106	6	6.30 mm, 8.30 mm, 10.40 mm, 12.40 mm, 16.50 mm, 20.50 mm
G2365	5	G506	6	6.30 mm, 8.30 mm, 10.40 mm, 12.40 mm, 16.50 mm, 20.50 mm

Code de matériau du corps (BMC)

Revêtement

Groupe standard de base (BSG)

Sens (direction de coupe)

Queue

Forme d'alésoir

Tolérance de trou réalisable (TCHA)

Dégradé conique - millimètre

HSS	HSS	HSS	HSS	HSS	HSS-E	HSS	HSS	HSS	HSS	HSS	HSS	HSS	HSS
Bright ST	Bright	Bright	Bright	Bright ST	Bright	Bright ST	Bright	Bright	Bright	Bright	Bright	Bright	ST Bronze
DIN 206	ANSI	ANSI	ANSI	BS 328	DIN 2179	DIN 9	DIN 9	ANSI	ANSI	ANSI	ANSI	ANSI	ANSI
B				A		A	B						
H7													
				1:48	1:50	1:50	1:50	1:48	1:48	1:48			

Code de famille de produits

Plage de diamètres de coupe PSF

B100	B610	B620	B650	B301	B953	B903	B952	B630	B660	B670	B680	B122
1.50 - 40.00	N60 - 1.1/2	1/16 - 1"	1/8 - 1"	3/32 - 1/2	2.00 - 12.00	1.50 - 20.00	1.20 - 40.00	7/0 - N10	N0 - N10	N0 - N10	1/8 - 1"	3/8 - 1"
74	76	78	79	80	81	82	83	84	85	86	87	88

P	P1	■	■	■	■	■	■	■	■	■	■	■	■
	P2	■	■	■	■	■	■	■	■	■	■	■	■
	P3	▣	■	■	■	■	▣	■	■	■	■	■	▣
	P4	▣	■	■	▣	▣	▣	▣	■	▣	▣	▣	▣
M	M1	▣	▣	▣	▣	▣	▣	▣	▣	▣	▣	▣	▣
	M2	▣	▣	▣	▣	▣	▣	▣	▣	▣	▣	▣	▣
	M3												
	M4												
K	K1	■	■	■	■	■	▣	▣	■	■	■	■	
	K2	▣	■	■	■	■	■	■	■	■	■	■	
	K3	■	▣	▣	■	▣	▣	▣	■	■	■	■	
	K4												
	K5												
N	N1	■	▣	■	■	■	▣	■	■	■	■	■	▣
	N2	■	▣	■	■	■	■	■	■	■	■	■	▣
	N3	■	■	■	■	■	▣	■	■	■	■	■	■
	N4	▣	▣		▣	▣	▣	▣	▣	▣	▣	▣	▣
	N5												
S	S1												
	S2												
	S3												
	S4												
H	H1												
	H2												
	H3												
	H4												

B100



Alésoir à main en HSS à queue cylindrique pour précision H7, finition brillante et ST

Alésoir principalement conçu pour être utilisé à la main. Il est doté d'une hélice à gauche rectifiée avec précision et d'une coupe à droite (sens des aiguilles d'une montre) pour un alésage en douceur, générant une taille de trou plus précise et une bonne finition de surface. Convient à l'alésage de nombreux matériaux, y compris les aciers.

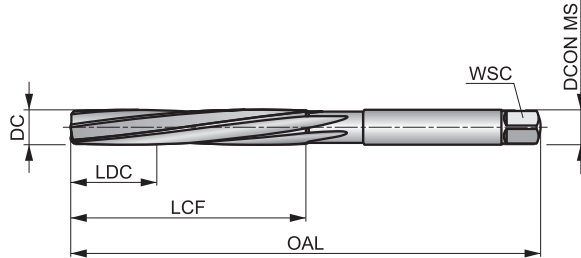

HSS	Bright ST	DIN 206
R		B
H7		

Adéquation du groupe de matériaux de la pièce.

P1.1	P1.2	P1.3	P2.1	P2.2	P2.3	P3.1	P3.2	P3.3	P4.1	P4.2	P4.3	M1.1	M1.2
■	■	■	■	■	■	■	■	■	■	■	■	■	■
M2.1	K1.1	K1.2	K1.3	K2.1	K2.2	K2.3	K3.1	K3.2	N1.1	N1.2	N1.3	N2.1	N2.2
■	■	■	■	■	■	■	■	■	■	■	■	■	■
N2.3	N3.1	N3.2	N3.3	N4.1	N4.2								
■	■	■	■	■	■								

DCON MS tolérance e9.

Product	DC	DC	OAL	LCF	LDC	NOF	WSC	DCON MS
	(inch)	(mm)	(mm)	(mm)	(mm)			
B1001.5	—	1.50	41.0	20.0	5.00	3	1.12	1.50
B1002.0	—	2.00	50.0	25.0	6.00	4	1.60	2.00
B1003/32	3/32	2.38	54.0	27.0	7.00	4	1.80	2.38
B1002.5	—	2.50	58.0	29.0	7.00	4	2.10	2.50
B1003.0	—	3.00	62.0	31.0	8.00	6	2.40	3.00
B1001/8	1/8	3.18	66.0	33.0	8.00	6	2.40	3.18
B1003.2	—	3.20	66.0	33.0	8.00	6	2.40	3.20
B1003.5	—	3.50	71.0	35.0	9.00	6	2.70	3.50
B1005/32	5/32	3.97	76.0	38.0	10.00	6	3.00	3.97
B1004.0	—	4.00	76.0	38.0	10.00	6	3.00	4.00
B1004.5	—	4.50	81.0	41.0	10.00	6	3.40	4.50
B1003/16	3/16	4.76	87.0	44.0	11.00	6	3.80	4.76
B1005.0	—	5.00	87.0	44.0	11.00	6	3.80	5.00
B1005.5	—	5.50	93.0	47.0	12.00	6	4.30	5.50
B1007/32	7/32	5.56	93.0	47.0	12.00	6	4.30	5.56
B1006.0	—	6.00	93.0	47.0	12.00	6	4.90	6.00
B1001/4	1/4	6.35	100.0	50.0	13.00	6	4.90	6.35
B1006.5	—	6.50	100.0	50.0	13.00	6	4.90	6.50
B10017/64	17/64	6.75	107.0	54.0	14.00	6	5.50	6.75
B1007.0	—	7.00	107.0	54.0	14.00	6	5.50	7.00
B1009/32	9/32	7.14	107.0	54.0	14.00	6	6.20	7.14
B1007.5	—	7.50	107.0	54.0	14.00	6	6.20	7.50
B1005/16	5/16	7.94	115.0	58.0	15.00	6	6.20	7.94
B1008.0	—	8.00	115.0	58.0	15.00	6	6.20	8.00
B10021/64	21/64	8.33	115.0	58.0	15.00	6	7.00	8.33
B1008.5	—	8.50	115.0	58.0	15.00	6	7.00	8.50
B10011/32	11/32	8.73	124.0	62.0	16.00	6	7.00	8.73



Product	DC	DC	OAL	LCF	LDC	NOF	WSC	DCON MS
	(inch)	(mm)	(mm)	(mm)	(mm)		(mm)	(mm)
B1009.0	–	9.00	124.0	62.0	16.00	6	7.00	9.00
B1009.5	–	9.50	124.0	62.0	16.00	6	8.00	9.50
B1003/8	3/8	9.52	124.0	62.0	17.00	6	8.00	9.52
B10010.0	–	10.00	133.0	66.0	17.00	6	8.00	10.00
B10013/32	13/32	10.32	133.0	66.0	17.00	6	8.00	10.32
B10010.5	–	10.50	133.0	66.0	17.00	6	8.00	10.50
B10011.0	–	11.00	142.0	71.0	18.00	6	9.00	11.00
B1007/16	7/16	11.11	142.0	71.0	18.00	6	9.00	11.11
B10011.5	–	11.50	142.0	71.0	18.00	6	9.00	11.50
B10012.0	–	12.00	152.0	76.0	19.00	6	9.00	12.00
B10012.5	–	12.50	152.0	76.0	19.00	6	10.00	12.50
B1001/2	1/2	12.70	152.0	76.0	19.00	6	10.00	12.70
B10013.0	–	13.00	152.0	76.0	19.00	6	10.00	13.00
B10013.5	–	13.50	163.0	81.0	20.00	8	11.00	13.50
B10014.0	–	14.00	163.0	81.0	20.00	8	11.00	14.00
B1009/16	9/16	14.29	163.0	81.0	20.00	8	11.00	14.29
B10014.5	–	14.50	163.0	81.0	20.00	8	11.00	14.50
B10015.0	–	15.00	163.0	81.0	20.00	8	12.00	15.00
B1005/8	5/8	15.88	175.0	87.0	22.00	8	12.00	15.88
B10016.0	–	16.00	175.0	87.0	22.00	8	12.00	16.00
B10017.0	–	17.00	175.0	87.0	22.00	8	13.00	17.00
B10018.0	–	18.00	188.0	93.0	23.00	8	14.50	18.00
B10019.0	–	19.00	188.0	93.0	23.00	8	14.50	19.00
B1003/4	3/4	19.05	188.0	93.0	25.00	8	14.50	19.05
B10020.0	–	20.00	201.0	100.0	25.00	8	16.00	20.00
B10021.0	–	21.00	201.0	100.0	25.00	8	16.00	21.00
B10022.0	–	22.00	215.0	107.0	27.00	8	18.00	22.00
B1007/8	7/8	22.22	215.0	107.0	27.00	8	18.00	22.22
B10023.0	–	23.00	215.0	107.0	27.00	8	18.00	23.00
B10024.0	–	24.00	231.0	115.0	29.00	8	18.00	24.00
B10025.0	–	25.00	231.0	115.0	29.00	8	20.00	25.00
B1001	1"	25.40	231.0	115.0	29.00	8	20.00	25.40
B10026.0	–	26.00	231.0	115.0	29.00	8	20.00	26.00
B10028.0	–	28.00	247.0	124.0	31.00	10	22.00	28.00
B10030.0	–	30.00	247.0	124.0	31.00	10	24.00	30.00
B10032.0	–	32.00	265.0	133.0	33.00	10	24.00	32.00
B10035.0	–	35.00	284.0	142.0	36.00	10	29.00	35.00
B10040.0	–	40.00	305.0	152.0	38.00	10	32.00	40.00

B610



Alésoir machine en HSS à queue cylindrique, finition brillante

Alésoir machine polyvalent avec des goujures plus courtes et plus profondes qu'un alésoir à main, il est conçu pour un alésage efficace dans la plupart des matériaux. Une vaste gamme de tailles est disponible, y compris les fractions, les calibres de fil, les lettres et les tailles décimales incrémentielles produites conformément à la norme ANSI B94.2-1983 (R1988).

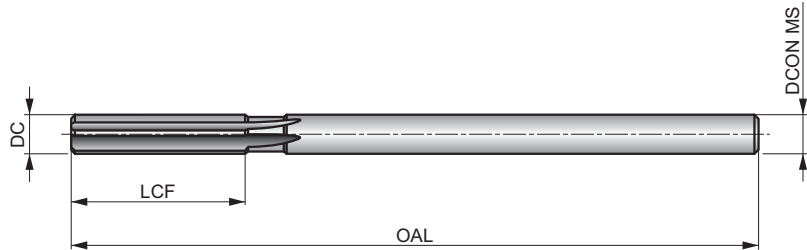

HSS	Bright	ANSI
R		

Adéquation du groupe de matériaux de la pièce, valeurs de départ pour la vitesse de coupe (m/min) et code Alpha d'avance. Les tableaux d'avances par tour se trouvent à partir de la page 279.

P1.1 19 C	P1.2 22 C	P1.3 23 C	P2.1 16 C	P2.2 14 C	P2.3 12 B	P3.1 11 B	P3.2 9 B	P3.3 7 A	P4.1 5 B	P4.2 4 A	P4.3 3	M1.1 9 C	M1.2 8 B
M2.1 7 B	K1.1 14 E	K1.2 10 D	K1.3 7 D	K2.1 14 C	K2.2 11 C	K2.3 9 C	K3.1 12 C	K3.2 9 C	N1.1 22 F	N1.2 16 F	N1.3 9 F	N2.1 25 E	N2.2 22 E
N2.3 14 E	N3.1 45 D	N3.2 26 E	N3.3 12 D	N4.1 28 B									

Product	DC (inch)	DC (Wire gauge size)	DC (inch)	DCON MS (inch)	LCF (inch)	OAL (inch)	NOF
B610N60	–	N60	0.0400	0.039	1/2	2.1/2	4
B610N59	–	N59	0.0410	0.039	1/2	2.1/2	4
B610N58	–	N58	0.0420	0.039	1/2	2.1/2	4
B610N57	–	N57	0.0430	0.039	1/2	2.1/2	4
B610N56	–	N56	0.0465	0.045	1/2	2.1/2	4
B6103/64	3/64	–	0.0469	0.045	1/2	2.1/2	4
B610N55	–	N55	0.0520	0.051	1/2	2.1/2	4
B610N54	–	N54	0.0550	0.051	1/2	2.1/2	4
B610N53	–	N53	0.0595	0.059	1/2	2.1/2	4
B6101/16	1/16	–	0.0625	0.059	1/2	2.1/2	4
B610N52	–	N52	0.0635	0.059	1/2	2.1/2	4
B610N51	–	N51	0.0670	0.066	3/4	3"	4
B610N50	–	N50	0.0700	0.066	3/4	3"	4
B610N49	–	N49	0.0730	0.066	3/4	3"	4
B610N48	–	N48	0.0760	0.072	3/4	3"	4
B6105/64	5/64	–	0.0781	0.072	3/4	3"	4
B610N47	–	N47	0.0785	0.072	3/4	3"	4
B610N46	–	N46	0.0810	0.077	3/4	3"	4
B610N45	–	N45	0.0820	0.077	3/4	3"	4
B610N44	–	N44	0.0860	0.081	3/4	3"	4
B610N43	–	N43	0.0890	0.081	3/4	3"	4
B610N42	–	N42	0.0935	0.088	3/4	3"	4
B6103/32	3/32	–	0.0938	0.088	3/4	3"	4
B610N41	–	N41	0.0960	0.093	7/8	3.1/2	4
B610N40	–	N40	0.0980	0.093	7/8	3.1/2	4
B610N39	–	N39	0.0995	0.093	7/8	3.1/2	4
B610N38	–	N38	0.1015	0.095	7/8	3.1/2	4
B610N37	–	N37	0.1040	0.095	7/8	3.1/2	4

Product	DC (inch)	DC (Wire gauge size)	DC (inch)	DCON MS (inch)	LCF (inch)	OAL (inch)	NOF
B610N36	–	N36	0.1065	0.103	7/8	3.1/2	4
B6107/64	7/64	–	0.1094	0.103	7/8	3.1/2	4
B610N35	–	N35	0.1100	0.103	7/8	3.1/2	4
B610N34	–	N34	0.1110	0.105	7/8	3.1/2	4
B610N33	–	N33	0.1130	0.105	7/8	3.1/2	4
B610N32	–	N32	0.1160	0.112	7/8	3.1/2	4
B610N31	–	N31	0.1200	0.112	7/8	3.1/2	4
B610.1230	–	–	0.1230	0.112	7/8	3.1/2	4
B610.1240	–	–	0.1240	0.119	7/8	3.1/2	4
B610.1247	–	–	0.1247	0.119	7/8	3.1/2	4
B6101/8	1/8	–	0.1250	0.119	7/8	3.1/2	4
B610.1260	–	–	0.1260	0.119	7/8	3.1/2	4
B610N30	–	N30	0.1285	0.119	7/8	3.1/2	4
B610N29	–	N29	0.1360	0.128	1"	4"	4
B610N28	–	N28	0.1400	0.135	1"	4"	4
B6109/64	9/64	–	0.1410	0.135	1"	4"	4
B610N27	–	N27	0.1440	0.135	1"	4"	4
B610N26	–	N26	0.1470	0.143	1"	4"	4
B610N25	–	N25	0.1495	0.143	1"	4"	4
B610N24	–	N24	0.1520	0.146	1"	4"	4
B610N23	–	N23	0.1540	0.146	1"	4"	4
B6105/32	5/32	–	0.1562	0.151	1"	4"	6
B610N22	–	N22	0.1570	0.151	1"	4"	6
B610N21	–	N21	0.1590	0.153	1.1/8	4.1/2	6
B610N20	–	N20	0.1610	0.153	1.1/8	4.1/2	6
B610N19	–	N19	0.1660	0.160	1.1/8	4.1/2	6
B610N18	–	N18	0.1695	0.160	1.1/8	4.1/2	6
B61011/64	11/64	–	0.1719	0.165	1.1/8	4.1/2	6



Product	DC	DC	DC	DCON	LCF	OAL	NOF
	(inch)	(Wire gauge size)	(inch)	(inch)	(inch)	(inch)	
B610N17	–	N17	0.1730	0.165	1.1/8	4.1/2	6
B610N16	–	N16	0.1770	0.170	1.1/8	4.1/2	6
B610N15	–	N15	0.1800	0.175	1.1/8	4.1/2	6
B610N14	–	N14	0.1820	0.175	1.1/8	4.1/2	6
B610N13	–	N13	0.1850	0.180	1.1/8	4.1/2	6
B610.1855	–	–	0.1855	0.180	1.1/8	4.1/2	6
B610.1865	–	–	0.1865	0.180	1.1/8	4.1/2	6
B610.1870	–	–	0.1870	0.180	1.1/8	4.1/2	6
B6103/16	3/16	–	0.1875	0.180	1.1/8	4.1/2	6
B610.1885	–	–	0.1885	0.180	1.1/8	4.1/2	6
B610N12	–	N12	0.1890	0.180	1.1/8	4.1/2	6
B610N11	–	N11	0.1910	0.186	1.1/4	5"	6
B610N10	–	N10	0.1935	0.186	1.1/4	5"	6
B610N9	–	N9	0.1960	0.190	1.1/4	5"	6
B610N8	–	N8	0.1990	0.190	1.1/4	5"	6
B610N7	–	N7	0.2010	0.195	1.1/4	5"	6
B61013/64	13/64	–	0.2031	0.195	1.1/4	5"	6
B610N6	–	N6	0.2040	0.195	1.1/4	5"	6
B610N5	–	N5	0.2055	0.202	1.1/4	5"	6
B610N4	–	N4	0.2090	0.202	1.1/4	5"	6
B610N3	–	N3	0.2130	0.207	1.1/4	5"	6
B6107/32	7/32	–	0.2188	0.207	1.1/4	5"	6
B610N2	–	N2	0.2210	0.217	1.1/2	6"	6
B610N1	–	N1	0.2280	0.217	1.1/2	6"	6
B610A	–	–	0.2340	0.227	1.1/2	6"	6
B61015/64	15/64	–	0.2344	0.227	1.1/2	6"	6
B610B	–	–	0.2380	0.233	1.1/2	6"	6
B610C	–	–	0.2420	0.233	1.1/2	6"	6
B610D	–	–	0.2460	0.233	1.1/2	6"	6
B610.2480	–	–	0.2480	0.233	1.1/2	6"	6
B610.2490	–	–	0.2490	0.240	1.1/2	6"	6
B610.2495	–	–	0.2495	0.240	1.1/2	6"	6
B6101/4	1/4	–	0.2500	0.240	1.1/2	6"	6
B610.2510	–	–	0.2510	0.240	1.1/2	6"	6
B610F	–	–	0.2570	0.248	1.1/2	6"	6
B610G	–	–	0.2610	0.248	1.1/2	6"	6
B61017/64	17/64	–	0.2656	0.248	1.1/2	6"	6
B610H	–	–	0.2660	0.248	1.1/2	6"	6
B610LETTERI	–	–	0.2720	0.248	1.1/2	6"	6
B610J	–	–	0.2770	0.248	1.1/2	6"	6
B610K	–	–	0.2810	0.248	1.1/2	6"	6
B6109/32	9/32	–	0.2812	0.248	1.1/2	6"	6
B610L	–	–	0.2900	0.279	1.1/2	6"	6
B610M	–	–	0.2950	0.279	1.1/2	6"	6
B61019/64	19/64	–	0.2969	0.279	1.1/2	6"	6
B610N	–	–	0.3020	0.279	1.1/2	6"	6
B610.3105	–	–	0.3105	0.279	1.1/2	6"	6
B610.3115	–	–	0.3115	0.279	1.1/2	6"	6
B610.3120	–	–	0.3120	0.279	1.1/2	6"	6
B6105/16	5/16	–	0.3125	0.279	1.1/2	6"	6
B610.3135	–	–	0.3135	0.279	1.1/2	6"	6
B610O	–	–	0.3160	0.279	1.1/2	6"	6
B610P	–	–	0.3230	0.279	1.1/2	6"	6
B61021/64	21/64	–	0.3281	0.279	1.1/2	6"	6
B610Q	–	–	0.3320	0.279	1.1/2	6"	6
B610R	–	–	0.3390	0.279	1.1/2	6"	6
B61011/32	11/32	–	0.3438	0.279	1.1/2	6"	6
B610S	–	–	0.3480	0.310	1.3/4	7"	6
B610T	–	–	0.3580	0.310	1.3/4	7"	6
B61023/64	23/64	–	0.3594	0.310	1.3/4	7"	6
B610U	–	–	0.3680	0.310	1.3/4	7"	6
B610.3730	–	–	0.3730	0.310	1.3/4	7"	6

Product	DC	DC	DC	DCON	LCF	OAL	NOF
	(inch)	(Wire gauge size)	(inch)	(inch)	(inch)	(inch)	
B610.3740	–	–	0.3740	0.310	1.3/4	7"	6
B610.3745	–	–	0.3745	0.310	1.3/4	7"	6
B6103/8	3/8	–	0.3750	0.310	1.3/4	7"	6
B610.3760	–	–	0.3760	0.310	1.3/4	7"	6
B610V	–	–	0.3770	0.310	1.3/4	7"	6
B610W	–	–	0.3860	0.310	1.3/4	7"	6
B61025/64	25/64	–	0.3910	0.310	1.3/4	7"	6
B610X	–	–	0.3970	0.310	1.3/4	7"	6
B610Y	–	–	0.4040	0.310	1.3/4	7"	6
B61013/32	13/32	–	0.4062	0.310	1.3/4	7"	6
B610Z	–	–	0.4130	0.373	1.3/4	7"	6
B61027/64	27/64	–	0.4219	0.373	1.3/4	7"	6
B610.4355	–	–	0.4355	0.373	1.3/4	7"	6
B610.4365	–	–	0.4365	0.373	1.3/4	7"	6
B610.4370	–	–	0.4370	0.373	1.3/4	7"	6
B6107/16	7/16	–	0.4375	0.373	1.3/4	7"	6
B610.4385	–	–	0.4385	0.373	1.3/4	7"	6
B61029/64	29/64	–	0.4531	0.373	1.3/4	7"	6
B61015/32	15/32	–	0.4688	0.373	1.3/4	7"	6
B61031/64	31/64	–	0.4844	0.435	2"	8"	6
B610.4980	–	–	0.4980	0.435	2"	8"	6
B610.4990	–	–	0.4990	0.435	2"	8"	6
B610.4995	–	–	0.4995	0.435	2"	8"	6
B6101/2	1/2	–	0.5000	0.435	2"	8"	6
B610.5010	–	–	0.5010	0.435	2"	8"	6
B61033/64	33/64	–	0.5156	0.435	2"	8"	6
B61017/32	17/32	–	0.5312	0.435	2"	8"	6
B61035/64	35/64	–	0.5469	0.435	2"	8"	8
B6109/16	9/16	–	0.5625	0.435	2"	8"	8
B61037/64	37/64	–	0.5781	0.435	2"	8"	8
B61019/32	19/32	–	0.5938	0.435	2"	8"	8
B61039/64	39/64	–	0.6094	0.562	2.1/4	9"	8
B6105/8	5/8	–	0.6250	0.562	2.1/4	9"	8
B61041/64	41/64	–	0.6410	0.562	2.1/4	9"	8
B61021/32	21/32	–	0.6562	0.562	2.1/4	9"	8
B61043/64	43/64	–	0.6719	0.562	2.1/4	9"	8
B61011/16	11/16	–	0.6875	0.562	2.1/4	9"	8
B61045/64	45/64	–	0.7031	0.562	2.1/4	9"	8
B61023/32	23/32	–	0.7188	0.562	2.1/4	9"	8
B61047/64	47/64	–	0.7344	0.625	2.1/2	9.1/2	8
B6103/4	3/4	–	0.7500	0.625	2.1/2	9.1/2	8
B61049/64	49/64	–	0.7656	0.625	2.1/2	9.1/2	8
B61025/32	25/32	–	0.7812	0.625	2.1/2	9.1/2	8
B61051/64	51/64	–	0.7969	0.625	2.1/2	9.1/2	8
B61013/16	13/16	–	0.8125	0.625	2.1/2	9.1/2	8
B61053/64	53/64	–	0.8281	0.625	2.1/2	9.1/2	8
B61027/32	27/32	–	0.8438	0.625	2.1/2	9.1/2	8
B61055/64	55/64	–	0.8594	0.750	2.5/8	10"	8
B6107/8	7/8	–	0.8750	0.750	2.5/8	10"	8
B61057/64	57/64	–	0.8910	0.750	2.5/8	10"	8
B61029/32	29/32	–	0.9062	0.750	2.5/8	10"	8
B61059/64	59/64	–	0.9219	0.750	2.5/8	10"	8
B61015/16	15/16	–	0.9375	0.750	2.5/8	10"	8
B61061/64	61/64	–	0.9531	0.750	2.5/8	10"	8
B61031/32	31/32	–	0.9688	0.750	2.5/8	10"	8
B61063/64	63/64	–	0.9844	0.875	2.3/4	10.1/2	8
B6101	1"	–	1.0000	0.875	2.3/4	10.1/2	8
B6101.1/16	1.1/16	–	1.0625	0.875	2.3/4	10.1/2	8
B6101.1/8	1.1/8	–	1.1250	0.875	2.7/8	11"	8
B6101.3/16	1.3/16	–	1.1875	1.000	2.7/8	11"	8
B6101.1/4	1.1/4	–	1.2500	1.000	3"	11.1/2	8
B6101.3/8	1.3/8	–	1.3750	1.000	3.1/4	12"	8
B6101.1/2	1.1/2	–	1.5000	1.250	3.1/2	12.1/2	8

B620



Alésoir en HSS à queue cylindrique et goujure avec hélice lente, finition brillante

Alésoir machine polyvalent avec des goujures plus courtes et plus profondes qu'un alésoir à main, il est conçu pour un alésage efficace dans la plupart des matériaux. Une vaste gamme de tailles est disponible, y compris les fractions, les calibres de fil, les lettres et les tailles décimales incrémentielles produites conformément à la norme ANSI B94.2-1983 (R1988).

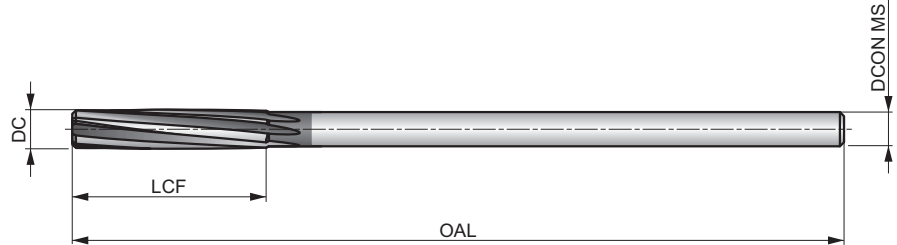

HSS	Bright	ANSI
R		

Adéquation du groupe de matériaux de la pièce, valeurs de départ pour la vitesse de coupe (m/min) et code Alpha d'avance. Les tableaux d'avances par tour se trouvent à partir de la page 279.

P1.1 ■ 21 C	P1.2 ■ 24 C	P1.3 ■ 25 C	P2.1 ■ 18 C	P2.2 ■ 16 C	P2.3 ■ 14 B	P3.1 ■ 13 B	P3.2 ■ 11 B	P3.3 ■ 9 B	P4.1 ■ 8 B	P4.2 ■ 7 B	P4.3 ■ 5 A	M1.1 ■ 11 C	M1.2 ■ 10 B
M2.1 ■ 9 B	M2.2 ■ 8 B	K1.1 ■ 16 E	K1.2 ■ 12 D	K1.3 ■ 9 D	K2.1 ■ 16 C	K2.2 ■ 13 C	K2.3 ■ 10 C	K3.1 ■ 14 C	K3.2 ■ 11 C	N1.1 ■ 24 F	N1.2 ■ 18 F	N1.3 ■ 11 F	N2.1 ■ 27 E
N2.2 ■ 24 E	N2.3 ■ 16 E	N3.1 ■ 47 D	N3.2 ■ 28 E	N3.3 ■ 14 D									

Product	DC (inch)	DC (Wire gauge size)	DC (inch)	DCON MS (inch)	LCF (inch)	OAL (inch)	NOF
B6201/16	1/16	—	0.0625	0.059	1/2	2.1/2	4
B6205/64	5/64	—	0.0781	0.072	3/4	3"	4
B6203/32	3/32	—	0.0938	0.088	3/4	3"	4
B6207/64	7/64	—	0.1094	0.103	7/8	3.1/2	4
B6201/8	1/8	—	0.1250	0.119	7/8	3.1/2	4
B6205/32	5/32	—	0.1562	0.151	1"	4"	6
B62011/64	11/64	—	0.1719	0.165	1.1/8	4.1/2	6
B6203/16	3/16	—	0.1875	0.180	1.1/8	4.1/2	6
B62013/64	13/64	—	0.2031	0.195	1.1/4	5"	6
B6207/32	7/32	—	0.2188	0.207	1.1/4	5"	6
B6201/4	1/4	—	0.2500	0.240	1.1/2	6"	6
B62017/64	17/64	—	0.2656	0.248	1.1/2	6"	6
B6209/32	9/32	—	0.2812	0.248	1.1/2	6"	6
B6205/16	5/16	—	0.3125	0.279	1.1/2	6"	6

Product	DC (inch)	DC (Wire gauge size)	DC (inch)	DCON MS (inch)	LCF (inch)	OAL (inch)	NOF
B62011/32	11/32	—	0.3438	0.279	1.1/2	6"	6
B6203/8	3/8	—	0.3750	0.310	1.3/4	7"	6
B62025/64	25/64	—	0.3910	0.310	1.3/4	7"	6
B62013/32	13/32	—	0.4062	0.310	1.3/4	7"	6
B6207/16	7/16	—	0.4375	0.373	1.3/4	7"	6
B62031/64	31/64	—	0.4844	0.435	2"	8"	6
B6201/2	1/2	—	0.5000	0.435	2"	8"	6
B62017/32	17/32	—	0.5312	0.435	2"	8"	6
B6209/16	9/16	—	0.5625	0.435	2"	8"	8
B6205/8	5/8	—	0.6250	0.562	2.1/4	9"	8
B62011/16	11/16	—	0.6875	0.562	2.1/4	9"	8
B6203/4	3/4	—	0.7500	0.625	2.1/2	9.1/2	8
B6207/8	7/8	—	0.8750	0.750	2.5/8	10"	8
B6201	1"	—	1.0000	0.875	2.3/4	10.1/2	8

B650



Alésoir à main HSS à goujure droite, finition brillante

Alésoir à main robuste à goujures droites utilisé pour la finition des trous percés à la main. Le carré d'entraînement permet de faire tourner l'outil à l'aide d'une clé ou de le monter de façon fixe pour les pièces rotatives. Convient à l'alésage de la plupart des matériaux, y compris les aciers. Fabriqué conformément à la norme ANSI B94.2-1983 (R1988).

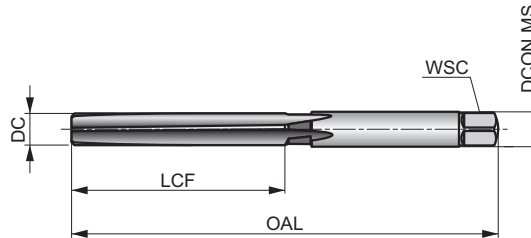

HSS	Bright	ANSI
R		

Adéquation du groupe de matériaux de la pièce.

P1.1	P1.2	P1.3	P2.1	P2.2	P2.3	P3.1	P3.2	P3.3	P4.1	P4.2	P4.3	M1.1	M1.2
■	■	■	■	■	■	■	■	■	■	■	■	■	■
M2.1	K1.1	K1.2	K1.3	K2.1	K2.2	K2.3	K3.1	K3.2	N1.1	N1.2	N1.3	N2.1	N2.2
■	■	■	■	■	■	■	■	■	■	■	■	■	■
N2.3	N3.1	N3.2	N3.3	N4.1	N4.2								
■	■	■	■	■	■								

Product	DC	DC	LCF	OAL	NOF
	(inch)	(inch)	(inch)	(inch)	
B6501/8	1/8	0.1250	1.1/2	3"	6
B6503/16	3/16	0.1875	1.3/4	3.1/2	6
B6501/4	1/4	0.2500	2"	4"	6
B6505/16	5/16	0.3125	2.1/4	4.1/2	6
B6503/8	3/8	0.3750	2.1/2	5"	6
B6507/16	7/16	0.4375	2.3/4	5.1/2	6
B6501/2	1/2	0.5000	3"	6"	6
B6509/16	9/16	0.5625	3.1/4	6.1/2	8
B6505/8	5/8	0.6250	3.1/2	7"	8
B6503/4	3/4	0.7500	4.3/16	8.3/8	8
B6507/8	7/8	0.8750	4.7/8	9.3/4	8
B6501	1"	1.0000	5.7/16	10.7/8	8

B301



Alésoir à main conique en HSS à queue cylindrique, conicité 1:48, finition brillante et ST

Alésoir conçu pour la finition des trous coniques acceptant des goupilles coniques impériales standard de rapport 1 à 48. Avec un petit diamètre réduit, l'outil se positionne et se centre facilement dans le trou pré-percé pour améliorer la précision et les performances. Convient pour l'alésage dans de nombreux matériaux.

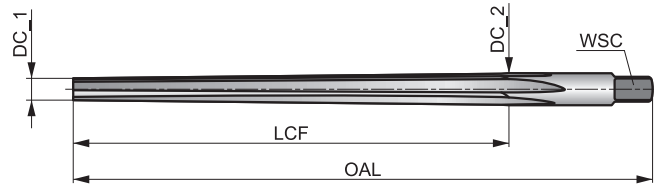

HSS	Bright ST	BS 328
R		A
1:48		

Adéquation du groupe de matériaux de la pièce.

P1.1	P1.2	P1.3	P2.1	P2.2	P2.3	P3.1	P3.2	P3.3	P4.1	P4.2	P4.3	M1.1	M1.2
■	■	■	■	■	■	■	■	■	■	■	■	■	■
M2.1	K1.1	K1.2	K1.3	K2.1	K2.2	K2.3	K3.1	K3.2	N1.1	N1.2	N1.3	N2.1	N2.2
■	■	■	■	■	■	■	■	■	■	■	■	■	■
N2.3	N3.1	N3.2	N3.3	N4.1	N4.2								
■	■	■	■	■	■								

DC ≤ 1/4 limite de tolérance +0.0030; DC >= 9/32 limite de tolérance +0.0050.

Product	nom d	DC_1	DC_2	OAL	LCF	NOF	WSC	DCON MS
		(mm)	(mm)	(mm)	(mm)			
B3013/32	3/32	1.75	2.41	57.0	32.0	4	2.00	2.41
B3011/8	1/8	2.30	3.23	70.0	44.0	4	2.50	3.23
B3015/32	5/32	2.95	4.01	76.0	51.0	4	3.10	4.01
B3013/16	3/16	3.50	4.95	102.0	70.0	4	4.00	4.95
B3011/4	1/4	4.64	6.43	117.0	86.0	6	5.00	6.43
B3015/16	5/16	5.84	8.03	143.0	105.0	6	6.30	8.03
B3013/8	3/8	7.03	9.68	165.0	127.0	6	8.00	9.68
B3011/2	1/2	9.41	12.85	210.0	165.0	6	10.00	12.85

B953



Alésoir à main en HSS-E pour goupille conique, à queue cylindrique, conicité 1:50, finition brillante
 Alésoir avec une spirale élevée, une hélice à gauche et une coupe à droite. Le cône de l'alésoir est conçu pour finir les trous coniques afin de recevoir des goupilles coniques métriques standard de rapport 1 à 50, tandis que l'entrée conique a un diamètre réduit pour améliorer les performances. Convient pour l'alésage dans de nombreux matériaux.

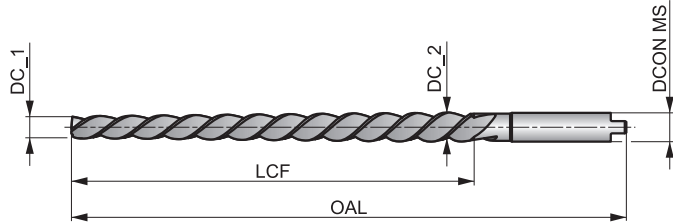

HSS-E	Bright	DIN 2179
R		1:50

Adéquation du groupe de matériaux de la pièce, valeurs de départ pour la vitesse de coupe (m/min) et code Alpha d'avance. Les tableaux d'avances par tour se trouvent à partir de la page 279.

P1.1 ■ 10 B	P1.2 ■ 12 B	P1.3 ■ 13 B	P2.1 ■ 9 B	P2.2 ■ 8 B	P2.3 ▣ 6 A	P3.1 ■ 7 A	P3.2 ▣ 6 A	P3.3 ▣ 3 A	P4.1 ■ 4 A	P4.2 ▣ 3 A	P4.3 ▣ 2 A	M1.1 ▣ 11 C	M1.2 ▣ 10 B
M2.1 ▣ 9 B	M2.2 ▣ 8 B	K1.1 ■ 10 C	K1.2 ■ 6 B	K1.3 ▣ 4 B	K2.1 ■ 8 A	K2.2 ■ 6 A	K2.3 ▣ 4 A	K3.1 ■ 7 A	K3.2 ▣ 4 A	N1.1 ▣ 14 D	N1.2 ■ 12 D	N1.3 ■ 9 D	N2.1 ■ 16 C
N2.2 ■ 14 C	N2.3 ▣ 10 C	N3.1 ■ 22 B	N3.2 ■ 14 C	N3.3 ▣ 6 B	N4.1 ▣ 22 B								

DCON MS tolérance h9.

Product	nom d	DC_1 (mm)	DC_2 (mm)	OAL (mm)	LCF (mm)	NOF	DCON MS (mm)
B9532.0	2.0	1.90	2.86	86.0	48.0	3	3.15
B9532.5	2.5	2.40	3.36	86.0	48.0	3	3.15
B9533.0	3.0	2.90	4.06	100.0	58.0	3	4.00
B9534.0	4.0	3.90	5.26	112.0	68.0	3	5.00
B9535.0	5.0	4.90	6.36	122.0	73.0	3	6.30
B9536.0	6.0	5.90	8.00	160.0	105.0	3	8.00
B9536.5	6.5	6.40	8.78	188.0	119.0	3	8.50
B9538.0	8.0	7.90	10.80	207.0	145.0	3	10.00
B95310.0	10.0	9.90	13.40	245.0	175.0	3	12.50
B95312.0	12.0	11.80	16.00	290.0	210.0	3	16.00

B903



Alésoir à main conique en HSS à queue cylindrique, conicité 1:50, finition brillante et ST

Alésoir conçu pour la finition des trous coniques acceptant des goupilles coniques métriques standard de rapport 1 à 50. Le diamètre de la petite extrémité est réduit pour faciliter le positionnement et le centrage de l'alésoir dans le trou. Convient pour l'alésage dans de nombreux matériaux.

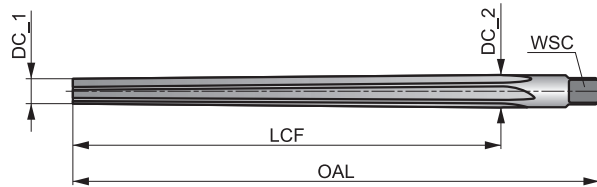

HSS	Bright ST	DIN 9
R		A
1:50		

Adéquation du groupe de matériaux de la pièce.

P1.1	P1.2	P1.3	P2.1	P2.2	P2.3	P3.1	P3.2	P3.3	P4.1	P4.2	P4.3	M1.1	M1.2
■	■	■	■	■	■	■	■	■	■	■	■	■	■
M2.1	K1.1	K1.2	K1.3	K2.1	K2.2	K2.3	K3.1	K3.2	N1.1	N1.2	N1.3	N2.1	N2.2
■	■	■	■	■	■	■	■	■	■	■	■	■	■
N2.3	N3.1	N3.2	N3.3	N4.1	N4.2								
■	■	■	■	■	■								

DCON MS tolérance h11; DC <= 5mm limite de tolérance +0.0750; DC > 5mm limite de tolérance +0.1250.

Product	nom d	DC_1	DC_2	OAL	LCF	NOF	WSC	DCON MS
		(mm)	(mm)	(mm)	(mm)		(mm)	(mm)
B9031.5	1.5	1.40	2.14	57.0	37.0	4	1.80	2.14
B9032.0	2.0	1.90	2.86	68.0	48.0	4	2.24	2.86
B9032.5	2.5	2.40	3.36	68.0	48.0	4	2.80	3.36
B9033.0	3.0	2.90	4.06	80.0	58.0	4	3.15	4.00
B9034.0	4.0	3.90	5.26	93.0	68.0	4	4.00	5.00
B9035.0	5.0	4.90	6.36	100.0	73.0	4	5.00	6.30
B9036.0	6.0	5.90	8.00	135.0	105.0	6	6.30	7.90
B9038.0	8.0	7.90	10.80	180.0	145.0	6	8.00	10.50
B90310.0	10.0	9.90	13.40	215.0	175.0	6	10.00	13.30
B90312.0	12.0	11.80	16.00	255.0	210.0	8	11.20	16.00
B90313.0	13.0	12.86	16.74	255.0	210.0	8	12.50	16.74
B90314.0	14.0	13.86	17.74	255.0	210.0	8	12.50	17.74
B90316.0	16.0	15.80	20.40	280.0	230.0	8	14.00	20.40
B90320.0	20.0	19.80	24.80	310.0	250.0	8	18.00	24.80

B952



Alésoir à main en HSS pour goupille conique, à queue cylindrique, conicité 1:50, finition brillante

Alésoir avec une hélice à gauche et une coupe à droite, permet d'obtenir un alésage en douceur pour une tolérance de trou plus précise et une meilleure finition. Le diamètre en bout de cet alésoir a été réduit, ce qui facilite le positionnement et le centrage de l'outil dans le trou. Convient pour l'alésage dans de nombreux matériaux.

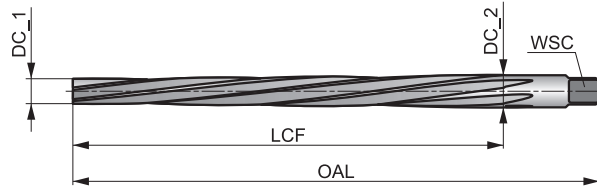

HSS	Bright	DIN 9
R		B
1:50		

Adéquation du groupe de matériaux de la pièce.

P1.1	P1.2	P1.3	P2.1	P2.2	P2.3	P3.1	P3.2	P3.3	P4.1	P4.2	P4.3	M1.1	M1.2
■	■	■	■	■	■	■	■	■	■	■	■	■	■
M2.1	K1.1	K1.2	K1.3	K2.1	K2.2	K2.3	K3.1	K3.2	N1.1	N1.2	N1.3	N2.1	N2.2
■	■	■	■	■	■	■	■	■	■	■	■	■	■
N2.3	N3.1	N3.2	N3.3	N4.1	N4.2								
■	■	■	■	■	■								

DCON MS tolérance h11; DC ≤ 2.5mm. Goujure droite, forme A.

Product	nom d	DC_1	DC_2	OAL	LCF	NOF	WSC	DCON MS
		(mm)	(mm)	(mm)	(mm)			
B9521.2	1.2	1.10	1.74	50.0	32.0	3	2.40	3.15
B9521.5	1.5	1.40	2.14	57.0	37.0	3	2.40	3.15
B9522.0	2.0	1.90	2.86	68.0	48.0	3	2.40	3.15
B9522.5	2.5	2.40	3.36	68.0	48.0	4	2.40	3.15
B9523.0	3.0	2.90	4.06	80.0	58.0	5	3.00	4.00
B9523.5	3.5	3.40	4.66	87.0	63.0	5	3.40	4.50
B9524.0	4.0	3.90	5.26	93.0	68.0	5	3.80	5.00
B9525.0	5.0	4.90	6.36	100.0	73.0	5	4.90	6.30
B9526.0	6.0	5.90	8.00	135.0	105.0	6	6.20	8.00
B9527.0	7.0	6.90	9.40	160.0	125.0	6	7.00	9.00
B9528.0	8.0	7.90	10.80	180.0	145.0	6	8.00	10.00
B9529.0	9.0	8.90	12.10	195.0	160.0	6	9.00	11.20
B95210.0	10.0	9.90	13.40	215.0	175.0	6	10.00	12.50
B95212.0	12.0	11.80	16.00	255.0	210.0	8	11.00	14.00
B95213.0	13.0	12.80	17.00	255.0	210.0	8	12.00	16.00
B95214.0	14.0	13.80	18.00	255.0	210.0	8	12.00	16.00
B95216.0	16.0	15.80	20.40	280.0	230.0	8	14.50	18.00
B95220.0	20.0	19.80	24.80	310.0	250.0	8	18.00	22.40
B95225.0	25.0	24.70	30.70	370.0	300.0	10	22.00	28.00
B95230.0	30.0	29.70	36.10	400.0	320.0	10	24.00	31.50
B95240.0	40.0	39.70	46.50	430.0	340.0	12	32.00	40.00

B630



Alésoir machine en HSS à queue cylindrique et type conique, finition brillante

L'hélice à droite permet à ces alésoirs d'effectuer des opérations plus douces et sans bavures que les alésoirs à goujures droites. Recommandés pour les matériaux plus difficiles à aléser, ils produisent de meilleurs états de surface, sont parfaits pour les interruptions et peuvent faciliter l'évacuation des copeaux dans les trous borgnes. Fabriqués conformément à la norme ANSI B94.2-1983 (R1988).

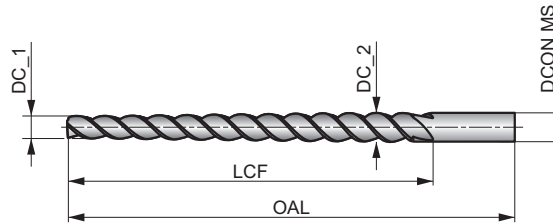

HSS	Bright	ANSI
R	1:48	

Adéquation du groupe de matériaux de la pièce, valeurs de départ pour la vitesse de coupe (m/min) et code Alpha d'avance. Les tableaux d'avances par tour se trouvent à partir de la page 279.

P1.1 ■ 10 B	P1.2 ■ 12 B	P1.3 ■ 13 B	P2.1 ■ 9 B	P2.2 ■ 8 B	P2.3 ▣ 6 A	P3.1 ■ 7 A	P3.2 ▣ 6 A	P3.3 ▣ 3 A	P4.1 ■ 4 A	P4.2 ▣ 3 A	P4.3 ▣ 2 A	M1.1 ▣ 11 C	M1.2 ▣ 10 B
M2.1 ▣ 9 B	M2.2 ▣ 8 B	K1.1 ■ 10 C	K1.2 ■ 6 B	K1.3 ▣ 4 B	K2.1 ■ 8 A	K2.2 ■ 6 A	K2.3 ▣ 4 A	K3.1 ■ 7 A	K3.2 ▣ 4 A	N1.1 ▣ 14 D	N1.2 ■ 12 D	N1.3 ■ 9 D	N2.1 ■ 16 C
N2.2 ■ 14 C	N2.3 ▣ 10 C	N3.1 ■ 22 B	N3.2 ■ 14 C	N3.3 ▣ 6 B	N4.1 ▣ 22 B								

Product	nom d	DC_1	DC_2	DCON MS	LCF	OAL	NOF
		(inch)	(inch)	(inch)	(inch)	(inch)	
B6307/0	7/0	0.0497	0.0666	5/64	13/16	1.13/16	2
B6306/0	6/0	0.0611	0.0810	3/32	15/16	1.15/16	2
B6305/0	5/0	0.0719	0.0966	7/64	1.3/16	2.3/16	2
B6304/0	4/0	0.0869	0.1142	1/8	1.5/16	2.5/16	2
B6303/0	3/0	0.1029	0.1300	9/64	1.5/16	5.5/16	2
B6302/0	2/0	0.1137	0.1462	5/32	1.9/16	2.9/16	3
B630N1	1	0.1447	0.1798	3/16	1.11/16	2.15/16	3
B630N2	2	0.1600	0.2010	13/64	1.15/16	3.3/16	3

Product	nom d	DC_1	DC_2	DCON MS	LCF	OAL	NOF
		(inch)	(inch)	(inch)	(inch)	(inch)	
B630N3	3	0.1813	0.2294	15/64	2.5/16	3.11/16	3
B630N4	4	0.2071	0.2600	17/64	2.9/16	4.1/16	3
B630N5	5	0.2410	0.2994	5/16	2.13/16	4.5/16	3
B630N6	6	0.2773	0.3540	23/64	3.11/16	5.7/16	3
B630N7	7	0.3297	0.4220	13/32	4.7/16	6.5/16	3
B630N8	8	0.3971	0.5050	7/16	5.3/16	7.3/16	3
B630N9	9	0.4800	0.6066	9/16	6.1/16	8.5/16	4
B630N10	10	0.5799	0.7216	5/8	6.13/16	9.5/16	4

B660



Alésoir à main en HSS à goujure droite, type conique, finition brillante

Conçu pour changer un trou cylindrique en trou conique (1/4" par pied) pour les goupilles coniques standard (ASA B5.20-1958). Le carré d'entraînement permet de faire tourner l'outil à l'aide d'une clé ou de le monter de façon fixe pour les pièces rotatives. Convient à l'alésage de la plupart des matériaux, y compris les aciers. Fabriqué conformément à la norme ANSI B94.2-1983 (R1988).

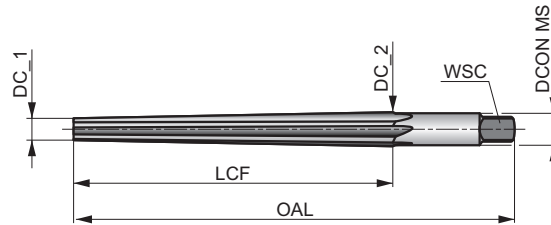

HSS	Bright	ANSI
R		1:48

Adéquation du groupe de matériaux de la pièce.

P1.1	P1.2	P1.3	P2.1	P2.2	P2.3	P3.1	P3.2	P3.3	P4.1	P4.2	P4.3	M1.1	M1.2
■	■	■	■	■	■	■	■	■	■	■	■	■	■
M2.1	K1.1	K1.2	K1.3	K2.1	K2.2	K2.3	K3.1	K3.2	N1.1	N1.2	N1.3	N2.1	N2.2
■	■	■	■	■	■	■	■	■	■	■	■	■	■
N2.3	N3.1	N3.2	N3.3	N4.1	N4.2								
■	■	■	■	■	■								

Product	nom d	DC_1 (inch)	DC_2 (inch)	DCON MS (inch)	LCF (inch)	OAL (inch)	WSC (inch)	NOF
B660N0	0	0.1287	0.1638	11/64	1.11/16	2.15/16	0.130	6
B660N1	1	0.1447	0.1798	3/16	1.11/16	2.15/16	0.140	6
B660N2	2	0.1600	0.2010	13/64	1.15/16	3.3/16	0.150	6
B660N3	3	0.1813	0.2294	15/64	2.5/16	3.11/16	0.175	6
B660N4	4	0.2071	0.2600	17/64	2.9/16	4.1/16	0.200	6
B660N5	5	0.2410	0.2994	5/16	2.13/16	4.5/16	0.235	6
B660N6	6	0.2773	0.3540	23/64	3.11/16	5.7/16	0.270	6
B660N7	7	0.3297	0.4220	13/32	4.7/16	6.5/16	0.305	6
B660N8	8	0.3971	0.5050	7/16	5.3/16	7.3/16	0.330	6
B660N9	9	0.4800	0.6066	9/16	6.1/16	8.5/16	0.420	8
B660N10	10	0.5799	0.7216	5/8	6.13/16	9.5/16	0.470	8

B670



Alésoir à main en HSS à goujure hélicoïdale, type conique, finition brillante

Coupe à droite avec hélice à gauche pour aléser un trou conique (1/4" par pied) pour les goupilles coniques standard (ASA B5.20-1958). Le carré d'entraînement permet de faire tourner l'outil ou de le monter en position statique pour les pièces en rotation. La goujure hélicoïdale améliore l'état de surface en facilitant l'évacuation des copeaux. Fabriqué selon la norme ANSI B94.2-1983 (R1988).

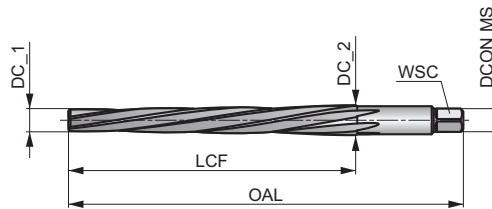

HSS	Bright	ANSI
R		1:48

Adéquation du groupe de matériaux de la pièce.

P1.1	P1.2	P1.3	P2.1	P2.2	P2.3	P3.1	P3.2	P3.3	P4.1	P4.2	P4.3	M1.1	M1.2
■	■	■	■	■	■	■	■	■	■	■	■	■	■
M2.1	K1.1	K1.2	K1.3	K2.1	K2.2	K2.3	K3.1	K3.2	N1.1	N1.2	N1.3	N2.1	N2.2
■	■	■	■	■	■	■	■	■	■	■	■	■	■
N2.3	N3.1	N3.2	N3.3	N4.1	N4.2								
■	■	■	■	■	■								

L'appellation d est le numéro de la goupille conique selon la spécification américaine standard des goupilles coniques (ASA B5.20-1958)

Product	nom d	DC_1	DC_2	DCON MS	LCF	OAL	WSC	NOF
		(inch)	(inch)	(inch)	(inch)	(inch)	(inch)	
B670N0	0	0.1287	0.1638	11/64	1.11/16	2.15/16	0.130	6
B670N1	1	0.1447	0.1798	3/16	1.11/16	2.15/16	0.140	6
B670N2	2	0.1600	0.2010	13/64	1.15/16	3.3/16	0.150	6
B670N3	3	0.1813	0.2294	15/64	2.5/16	3.11/16	0.175	6
B670N4	4	0.2071	0.2600	17/64	2.9/16	4.1/16	0.200	6
B670N5	5	0.2410	0.2994	5/16	2.13/16	4.5/16	0.235	6
B670N6	6	0.2773	0.3540	23/64	3.11/16	5.7/16	0.270	6
B670N7	7	0.3297	0.4220	13/32	4.7/16	6.5/16	0.305	6
B670N8	8	0.3971	0.5050	7/16	5.3/16	7.3/16	0.330	6
B670N9	9	0.4800	0.6066	9/16	6.1/16	8.5/16	0.420	8
B670N10	10	0.5799	0.7216	5/8	6.13/16	9.5/16	0.470	8

B680



Alésoir à main en HSS à goujure hélicoïdale, type conique NPT, finition brillante

Coupe à droite avec hélice à gauche pour aléser un trou conique (3/4" par pied) avant le taraudage NPT. Le carré d'entraînement permet de faire tourner l'outil ou de le monter en position statique pour les pièces rotatives. La goujure en hélice améliore l'état de surface en facilitant l'évacuation des copeaux. Fabriqué conformément à la norme ANSI B94.2-1983 (R1988).

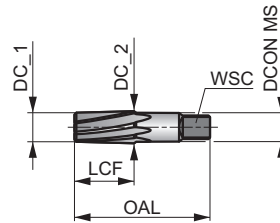

HSS	Bright	ANSI
R		

Adéquation du groupe de matériaux de la pièce.

P1.1	P1.2	P1.3	P2.1	P2.2	P2.3	P3.1	P3.2	P3.3	P4.1	P4.2	P4.3	M1.1	M1.2
■	■	■	■	■	■	■	■	■	■	■	■	■	■
M2.1	K1.1	K1.2	K1.3	K2.1	K2.2	K2.3	K3.1	K3.2	N1.1	N1.2	N1.3	N2.1	N2.2
■	■	■	■	■	■	■	■	■	■	■	■	■	■
N2.3	N3.1	N3.2	N3.3	N4.1	N4.2								
■	■	■	■	■	■								

L'appellation d est la taille du filetage NPT.

Product	nom d	DC_1	DC_2	DCON MS	LCF	OAL	WSC	NOF
		(inch)	(inch)	(inch)	(inch)	(inch)	(inch)	
B6801/8	1/8	0.3160	0.3620	0.438	3/4	2.1/8	0.328	6
B6801/4	1/4	0.4060	0.4720	0.563	1.1/16	2.7/16	0.421	6
B6803/8	3/8	0.5400	0.6060	0.700	1.1/16	2.9/16	0.531	8
B6801/2	1/2	0.6650	0.7510	0.688	1.3/8	3.1/8	0.575	8
B6803/4	3/4	0.8760	0.9620	0.906	1.3/8	3.1/4	0.679	10
B6801	1"	1.1030	1.2120	1.125	1.3/4	3.3/4	0.843	10

B122



Alésoir à main en HSS à queue réduite, avec traitement vapeur et finition bronze

Alésoir conçu pour réaligner les trous dans les tôles ou pièces en acier à paroi mince avant de les boulonner ou de les riveter. Il est conçu pour être utilisé à la main. Le petit diamètre du pilote facilite le repérage et l'alignement de l'outil dans les trous pré-perçés. Convient à de nombreux matériaux.

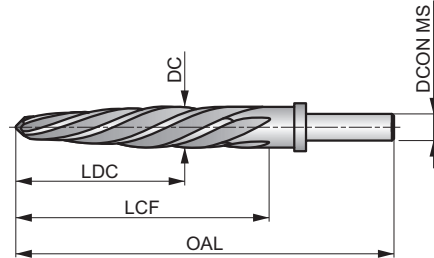

HSS	ST Bronze	ANSI
R		

Adéquation du groupe de matériaux de la pièce, valeurs de départ pour la vitesse de coupe (m/min) et code Alpha d'avance. Les tableaux d'avances par tour se trouvent à partir de la page 279.

P1.1 ■ 15 C	P1.2 ■ 16 C	P1.3 ■ 17 C	P2.1 ■ 13 C	P2.2 ■ 11 C	P3.1 ■ 7 B	M1.1 ■ 11 C	M1.2 ■ 10 B	M2.1 ■ 9 B	N1.1 ■ 23 F	N1.2 ■ 17 F	N2.1 ■ 23 E	N2.2 ■ 21 E	N3.1 ■ 34 D
N3.2 ■ 20 E	N4.1 ■ 22 B	N4.2 ■ 21 B											

Product	DC (inch)	DC (inch)	OAL (inch)	LCF (inch)	NOF	DCON MS (inch)
B1223/8	3/8	0.3750	4.5/8	2.1/2	4	3/8
B1221/2	1/2	0.5000	5.7/8	3.3/4	5	1/2
B1229/16	9/16	0.5625	5.7/8	3.3/4	5	1/2
B1225/8	5/8	0.6250	6.3/8	4.1/4	5	1/2
B12211/16	11/16	0.6875	6.3/8	4.1/4	5	1/2
B1223/4	3/4	0.7500	6.7/8	4.1/2	5	1/2
B12213/16	13/16	0.8125	6.7/8	4.1/2	5	1/2
B1227/8	7/8	0.8750	6.7/8	4.1/2	5	1/2
B12215/16	15/16	0.9375	6.7/8	4.1/2	5	1/2
B1221	1"	1.0000	6.7/8	4.1/2	5	1/2

Code de matériau du corps (BMC)
 Groupe standard de base (BSG)
 Rapport longueur utile diamètre (ULDR)
 Angle d'application
 Revêtement
 Queue
 Forme de spirale
 Sens (direction de coupe)

HSS	HSS	HSS	HSS	HSS	HSS	HSS	HSS
DIN ANSI	DIN 338	DIN 338	DIN 338	DIN 338	DIN 338	DIN 338	DIN 338
2.5xD	4xD	4xD	4xD	4xD	4xD	4xD	4xD



Code de famille de produits
 Plage de diamètres de coupe PSF

A088	A089	A087	A094	A095	A099 Drillboy	A188
Set	Set	Set	Set	Set	Set	Set

P	P1					
	P2					
	P3					
	P4					
M	M1					
	M2					
	M3					
	M4					
K	K1					
	K2					
	K3					
	K4					
	K5					
N	N1					
	N2					
	N3					
	N4					
	N5					
S	S1					
	S2					
	S3					
	S4					
H	H1					
	H2					
	H3					
	H4					

HSS-E	HSS	HSS	HSS	Cr steel
DIN 338	DIN 338	DIN 338	DIN 338	
4×D	4×D	4×D	4×D	



A295	A190	A191	A191_2	M900	M901	M902	A080
------	------	------	--------	------	------	------	------

Set	Set	Set	Set	Size 1 - 9	Set	Set	Set
-----	-----	-----	-----	------------	-----	-----	-----

95	96	97	97	98	99	99	99
----	----	----	----	----	----	----	----

P1				■			
P2				■			
P3				■			
P4				■			
M1				■			
M2				■			
M3				■			
M4				■			
K1				■			
K2				■			
K3				■			
K4				■			
K5				■			
N1				■			
N2				■			
N3				■			
N4				■			
N5				■			
S1							
S2							
S3							
S4							
H1							
H2							
H3							
H4							

A088



Coffret de forets extra-court A022 en HSS, revêtement TiN en pointe

Coffret robuste contenant 24 diamètres différents de forets extra-courts A022. Les forets conviennent à la fois au perçage sur machines et manuel dans de nombreuses applications. Le revêtement TiN en pointe améliore les performances et prolonge la durée de vie de l'outil.

HSS	DIN ANSI	2.5xD
135°	TiN-Tip	
λ 20-35°	R	DC h8

A=Types dans le coffret, B=Quantité dans le coffret, C=Diamètres dans le coffret.

Product	Nr.	A	B	C
A0882005	2005	A022	24	1.0 mm - 10.5 mm x 0.5 mm + 3.3 mm, 4.2 mm, 6.8 mm, 10.2 mm

A089



Coffret de forets courts A002 en HSS, revêtement TiN en pointe

Coffret pratique contenant 5 diamètres différents de forets populaires A002. Les forets conviennent à la fois au perçage sur machines et manuel dans de nombreuses applications. Le revêtement TiN en pointe améliore les performances et prolonge la durée de vie de l'outil.

HSS	DIN 338	4xD
118°	TiN-Tip	
λ 20-35°	R	DC h8

A=Types dans le coffret, B=Quantité dans le coffret, C=Diamètres dans le coffret.

Product	Nr.	A	B	C
A08910	10	A002	5	A0024.0, A0025.0, A0026.0, A0028.0, A00210.0

A087



Coffret de forets courts A002 en HSS, revêtement TiN en pointe

Coffret compact facile à transporter contenant 19 diamètres différents de forets populaires A002, avec les tailles clairement affichées pour faciliter la sélection. Les forets conviennent à la fois au perçage sur machines et manuel ainsi que pour de nombreuses applications. Le revêtement TiN en pointe améliore les performances et prolonge la durée de vie de l'outil.

HSS	DIN 338	4xD
118°	TiN-Tip	
λ.20-35°	R	DC h8

A=Types dans le coffret, B=Quantité dans le coffret, C=Diamètres dans le coffret. 1.0mm =< DC >= 2.9mm avec pointe 4 facettes à 118°.

Product	Nr.	A	B	C
A087201	201	A002	19	1.0 mm - 10.0 mm x 0.5 mm

A094



Coffret de forets courts A002 en HSS, revêtement TiN en pointe

Coffret rotatif contenant des forets A002 de différents diamètres métriques astucieusement conçu pour faciliter la sélection de la taille requise. Faites pivoter le dessus en plastique transparent jusqu'à ce que la taille requise soit mise en évidence par le trou dans le boîtier, et retournez l'ensemble pour retirer le foret.

HSS	DIN 338	4xD
118°	TiN-Tip	
λ.20-35°	R	DC h8

A=Types dans le coffret, B=Quantité dans le coffret, C=Diamètres dans le coffret. 1.0mm =< DC >= 2.9mm avec pointe 4 facettes à 118°.

Product	Nr.	A	B	C
A094413	413	A002	13	1.5 mm - 6.5 mm x 0.5 mm + 3.3 mm, 4.2 mm
A094419	419	A002	19	1.0 mm - 10.0 mm x 0.5 mm

A095

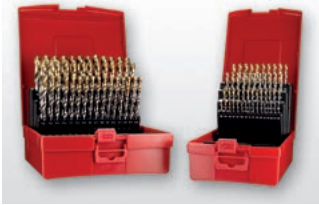

Coffret de forets courts A002 en HSS, revêtement TiN en pointe

Coffrets utile en plastique avec différentes tailles métriques, par incréments de 0,5 mm, de nos forets A002. Le coffret regroupe tous les forets ensemble, avec les tailles clairement affichées pour une sélection plus facile. Les forets conviennent à la fois aux machines et aux appareils portatifs. Le revêtement TiN en pointe améliore les performances et prolonge la durée de vie de l'outil.

HSS	DIN 338	4xD
118°	TiN-Tip	
λ 20-35°		DC h8

1.0mm =< DC >= 2.9mm avec pointe 4 facettes à 118°. A=Types dans le coffret, B=Quantité dans le coffret, C=Diamètres dans le coffret.

Product	Nr.	A	B	C
A09518	18	A002	29	1/16 inch - 1/2 inch x 1/64 inch
A095200	200	A002	24	1.0 mm - 10.5 mm x 0.5 mm + 3.3 mm, 4.2 mm, 6.8 mm, 10.2 mm
A095201	201	A002	19	1.0 mm - 10.0 mm x 0.5 mm
A095202	202	A002	51	1.0 mm - 6.0 mm x 0.1 mm
A095203	203	A002	41	6.0 mm - 10.0 mm x 0.1 mm
A095204	204	A002	25	1.0 mm - 13.0 mm x 0.5 mm
A095206	206	A002	29	1.0 mm - 13.0 mm x 0.5 mm + 3.3 mm, 4.2 mm, 6.8 mm, 10.2 mm
A095209	209	A002	91	1.0 mm - 10.0 mm x 0.1 mm

A099 Drillboy



Présentoir Drillboy avec forets courts A002 en HSS, revêtement TiN en pointe

Présentoir autonome de comptoir contenant une large gamme de tailles de forets A002. Conçu pour être posé sur un comptoir ou toute autre surface plane appropriée pour un affichage bien visible et où les forets peuvent être facilement retirés en cas de besoin. Facile à recharger avec d'autres forets A002, il vous rendra service pendant des années.

HSS	DIN 338	4xD
118°	TiN-Tip	
λ 20-35°		DC h8

1.0mm =< DC >= 2.9mm avec pointe 4 facettes à 118°. A=Types dans le coffret, B=Quantité dans le coffret, C=Diamètres dans le coffret.

Product	Nr.	A	B	C
A099DRILLBOYXL	DRILLBOY	A002	55	3 x (1.0, 1.5, 2.0, 2.5, 3.0, 3.3, 3.5, 4.0) + 2 x (4.2, 4.5, 5.0, 5.5, 6.0, 6.5, 6.8, 7.0, 7.5, 8.0) + 8.5, 9.0, 9.5, 10.0, 10.2, 10.5, 11.0, 11.5, 12.0, 12.5, 13.0 mm





A188

DORMER



Coffret de forets courts A108 en HSS, finition avec traitement vapeur

Coffret utile en plastique avec différentes tailles de forets A108. Peut être utilisé dans de nombreuses applications sur machines et manuelles.

HSS	DIN 338	4xD
 135°	 ST	
 λ > 35°	 R	DC h8

A=Types dans le coffret, B=Quantité dans le coffret, C=Diamètres dans le coffret. DC > 1.5mm; 1/16" avec affûtage en croix.

Product	Nr.	A	B	C
A188201	201	A108	19	1.0 mm - 10.0 mm x 0.5 mm
A188204	204	A108	25	1.0 mm - 13.0 mm x 0.5 mm





A295

DORMER



Coffret de forets courts A777 en HSS-E (8% cobalt), finition bronze

Coffret utile en plastique avec différentes tailles, par incréments de 0,5 mm, de nos forets A777. Il regroupe tous les forets ensemble et dans l'ordre, avec les tailles clairement affichées pour une sélection plus facile. Les forets A777 sont conçus avec une pointe à 135° avec affûtage en croix pour aider à centrer automatiquement le foret et réduire les forces de coupe.

HSS-E	DIN 338	4xD
 135°	 Bronze	
 λ 20-35°	 R	DC h8

A=Types dans le coffret, B=Quantité dans le coffret, C=Diamètres dans le coffret. DC ≤ 1.4mm avec pointe 4 facettes.

Product	Nr.	A	B	C
A295219	219	A777	19	1.0 mm - 10.0 mm x 0.5 mm
A295225	225	A777	25	1.0 mm - 13.0 mm x 0.5 mm

A190



Coffret de forets courts A100 en HSS, finition avec traitement vapeur

Coffret pratique en plastique contenant des forets courts A100 avec pointe conventionnelle à 118°. Fourni en jeux de tailles métriques par incréments de 0,1 mm ou 0,5 mm et en pouces rangés pour faciliter la sélection de la taille de foret.

HSS	DIN 338	4xD
118°	ST	
λ 20-35°	R	DC h8

A=Types dans le coffret, B=Quantité dans le coffret, C=Diamètres dans le coffret. DC <= 1mm; 3/64"; N60 Brillant.

Product	Nr.	A	B	C
A1903	3	A100	21	1/16 inch - 3/8 inch x 1/64 inch
A19012	12	A100	60	No.1 - No.60
A19018	18	A100	29	1/16 inch - 1/2 inch x 1/64 inch
A19020	20	A100	15	1/16 inch - 1/2 inch x 1/32 inch
A190201	201	A100	19	1.0 mm - 10.0 mm x 0.5 mm
A190202	202	A100	51	1.0 mm - 6.0 mm x 0.1 mm
A190203	203	A100	41	6.0 mm - 10.0 mm x 0.1 mm
A190204	204	A100	25	1.0 mm - 13.0 mm x 0.5 mm
A190206	206	A100	29	1.0 mm - 13.0 mm x 0.5 mm + 3.3 mm, 4.2 mm, 6.8 mm, 10.2 mm
A190209 ¹⁾	209	A100	91	1.0 mm - 10.0 mm x 0.1 mm

¹⁾ Vendu en 2 boîtes: boîte 1 contient les tailles (1.0-5.9 x 0.1mm); boîte 2 contient les tailles (6.0-10.0 x 0.1mm).

A191



Coffret de forets courts A100 en HSS, finition avec traitement vapeur

Coffret contenant des forets A100 de différents diamètres métriques dans un boîtier compact facile à transporter avec des tailles clairement affichées et une sélection de forets plus facile. Forets courts A100 avec pointe conventionnelle à 118°. Fourni en jeux de tailles métriques ou en pouces dans un boîtier en plastique pratique qui facilite la sélection de la taille de foret.

HSS	DIN 338	4xD
118°	Bright	
λ 20-35°	R	DC h8

A=Types dans le coffret, B=Quantité dans le coffret, C=Diamètres dans le coffret. DC <= 1mm; 3/64"; N60 Brillant.

Product	Nr.	A	B	C
A19131M	31M	A100	20	0.3 mm - 1.0 mm x 0.05 mm + 0.38 mm, 0.52 mm, 0.58 mm, 0.78 mm, 0.82 mm

A191_2



Coffret de forets courts A100 en HSS, finition avec traitement vapeur

Coffret rotatif contenant des forets A100 de différents diamètres métriques astucieusement conçu pour faciliter la sélection de la taille requise. Faites pivoter le dessus en plastique transparent jusqu'à ce que la taille requise soit mise en évidence par le trou dans le boîtier, et retournez l'ensemble pour retirer le foret.

HSS	DIN 338	4xD
118°	ST	
λ 20-35°	R	DC h8

A=Types dans le coffret, B=Quantité dans le coffret, C=Diamètres dans le coffret. DC <= 1mm; 3/64"; N60 Brillant.

Product	Nr.	A	B	C
A191413	413	A100	13	1.5 mm - 6.5 mm x 0.5 mm + 3.3 mm, 4.2 mm
A191419	419	A100	19	1.0 mm - 10.0 mm x 0.5 mm

M900







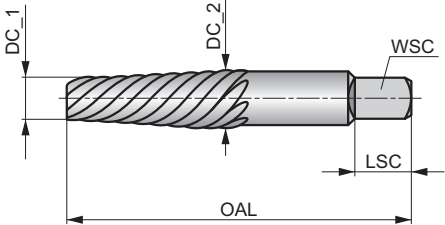

Extracteur de vis

L'extracteur de vis est utilisé dans le sens inverse des aiguilles d'une montre pour retirer les boulons à droite cassés dans des trous taraudés sans endommager les filets. Il est nécessaire de percer un trou de guidage de la bonne taille avant d'utiliser l'extracteur.



Taille du foret A : A utiliser pour les vis à faible ou moyenne résistance à la traction. B : A utiliser pour les vis à haute résistance à la traction

Product							DC_1	DC_2	WSC	LSC	OAL
		(mm)	(mm)	(inch)	(inch)	(inch)					
M9001	M5 - M6	2	2	3/16" - 1/4"	5/64	5/64	1.37	3.20	2.60	5.1	51.1
M9002	M6 - M8	2.8	3	1/4" - 5/16"	7/64	1/8	2.18	4.80	3.90	6.7	61.1
M9003	M8 - M12	4	4.2	5/16" - 7/16"	5/32	11/64	3.18	6.40	4.80	7.5	68.7
M9004	M12 - M14	5.5	6	7/16" - 9/16"	7/32	15/64	4.37	8.00	6.00	8	76.7
M9005	M14 - M20	7.2	8	9/16" - 3/4"	9/32	5/16	6.35	11.10	8.30	11.5	86.1
M9006	M20 - M30	10.5	11	3/4" - 1"	13/32	7/16	9.53	15.90	11.90	13.1	94.4
M9007	M30 - M42	13.5	14.5	1" - 1.3/8"	17/32	9/16	12.30	19.10	14.30	17.9	107.4
M9008	M42 - M45	20.5	21.5	1.3/8" - 1.3/4"	13/16	27/32	18.65	25.10	19.80	19.4	114.3
M9009	M45 - M50	27	28	1.3/4 - 2.1/8	1.1/16	1.3/32	24.61	32.30	24.60	22.6	121.3



M901

DORMER



Set d'extracteur de vis

Set d'extracteur de vis de tailles M9001 à M9005 ou M9001 à M9006.

A=Types dans le coffret, B=Quantité dans le coffret, C=Diamètres dans le coffret.

Product	Nr.	A	B	C
M901A	A	M900	5	M9001-M9005
M901B	B	M900	6	M9001-M9006

M902



Kit extracteur de vis

Les outils pour retirer les boulons cassés (avec filets à droite) sont livrés par kit de quatre. Dans un premier temps, utilisez la fraise à font plat P100 pour aplatir le boulon. Dans un deuxième temps, utilisez la fraise conique P101 pour créer un centre de départ. Dans un troisième temps, utilisez le foret court HSS-E A117 pour percer un trou pour l'extracteur. Enfin, utilisez l'extracteur de vis dans le sens anti-horaire pour retirer le boulon cassé sans abîmer les filets.

A=Types dans le coffret, B=Quantité dans le coffret, C=Diamètres dans le coffret.

Product	Nr.	A	B	C
M902M6-M8	M6-M8	M900, P100, P101, A117	4	P1004.9, P1014.9, A1173.0, M9002
M902M8-M10	M8-M10	M900, P100, P101, A117	4	P1006.4, P1016.4, A1174.0, M9003
M902M10-M12	M10-M12	M900, P100, P101, A117	4	P1007.8, P1017.8, A1174.2, M9003
M902M12-M14	M12-M14	M900, P100, P101, A117	4	P1009.3, P1019.3, A1176.0, M9004
M902M14-M16	M14-M16	M900, P100, P101, A117	4	P10010.7, P10110.7, A1178.0, M9005

A080

DORMER



Présentoir vide

Présentoir fourni vide afin que les forets puissent être achetés séparément en choisissant les quantités en fonction des ventes au comptoir. Il est en plastique rouge marqué du logo Dormer et d'une image de différents forets Dormer. Les diamètres des forets sont indiqués sur les trois étagères.

Présentoir vide.

Product	Nr.	C
A080M1EMPTY	M1EMPTY	(1.00, 1.50, 2.00, 2.50, 3.00, 3.50, 4.00, 4.50, 5.00, 5.50, 6.00, 6.50, 7.00, 7.50, 8.00, 8.50, 9.00, 9.50, 10.00, 10.50, 11.00, 11.50, 12.00) mm
A080F1EMPTY	F1EMPTY	(1/16, 5/64, 3/32, 7/64, 1/8, 9/64, 5/32, 11/64, 3/16, 13/64, 7/32, 15/64, 1/4, 17/64, 9/32, 19/64, 5/16, 21/64, 11/32, 3/8, 13/32, 7/16, 1/2) inch



**OUTILS POUR LA FABRICATION MIXTE.
GÉNÉRALEMENT UTILISÉS AVEC DES MACHINES
CONVENTIONNELLES AVEC ALIMENTATION DE LA MACHINE ET CNC.**

Code de matériau du corps (BMC)	HSS-E	HSS	HSS-E	HSS-E	HSS-E	HM								
Groupe standard de base (BSG)	DIN 1899	DIN 1897	DIN 1897	DIN 1897	DIN ANSI	DIN 6539								
Rapport longueur utile diamètre (ULDR)	2.5xD	2.5xD	2.5xD	2.5xD	3xD	2.5xD								
Angle d'application	118°	130°	130°	135°	130°	120°								
Revêtement	Bright	TiN	Bronze	Bronze	Bright	TiN-Tip								
Queue														
Forme de spirale	λ20-35°	λ32-40°	λ20-35°	λ20-35°	λ>35°	λ20-35°								
Sens (direction de coupe)														
		ADX			PFX									

Code de famille de produits		A720	A520	A620	A117	A920	R023							
Plage de diamètres de coupe PSF		0.15 - 1.40	3.00 - 13.00	2.50 - 13.00	1.00 - 13.00	1.00 - 20.00	1.00 - 12.00							
P	P1	■	■	■	■	■	■							
	P2	■	■	■	■	■	■							
	P3	■	■	■	■	■	■							
	P4	■	■	■	■	■	■							
M	M1	■	■	■	■	■	■							
	M2	■	■	■	■	■	■							
	M3	■	■	■	■	■	■							
	M4	■	■	■	■	■	■							
K	K1	■	■	■	■	■	■							
	K2	■	■	■	■	■	■							
	K3	■	■	■	■	■	■							
	K4	■	■	■	■	■	■							
	K5	■	■	■	■	■	■							
N	N1	■	■	■	■	■	■							
	N2	■	■	■	■	■	■							
	N3	■	■	■	■	■	■							
	N4	■	■	■	■	■	■							
	N5	■	■	■	■	■	■							
S	S1	■	■	■	■	■	■							
	S2	■	■	■	■	■	■							
	S3	■	■	■	■	■	■							
	S4	■	■	■	■	■	■							
H	H1						■							
	H2						■							
	H3						■							
	H4													

A720



Micro-foret en HSS-E (5% cobalt), finition brillante

Micro-foret de très petits diamètres allant de 0,15 mm à 1,40 mm. Pour faciliter la tenue de l'outil, tous les forets ont un diamètre de queue de 1,00 mm ou 1,50 mm. Les forets ont tous une pointe à 118° à 4 facettes qui facilite l'auto-centrage et réduit les forces de coupe.

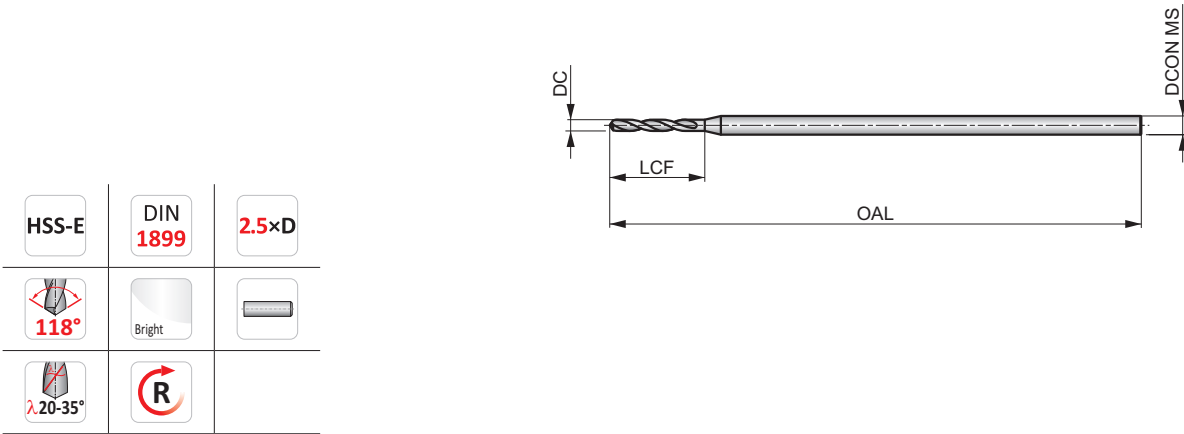

HSS-E	DIN 1899	2.5xD
118°	Bright	
λ 20-35°	R	

Adéquation du groupe de matériaux de la pièce, valeurs de départ pour la vitesse de coupe (m/min) et code Alpha d'avance. Les tableaux d'avances par tour se trouvent à partir de la page 274.

P1.1 ■ 36 A	P1.2 ■ 40 A	P1.3 ■ 41 A	P2.1 ■ 31 A	P2.2 ■ 27 A	P2.3 ▣ 24 A	P3.1 ■ 25 A	P3.2 ■ 20 A	P3.3 ▣ 17 A	P4.1 ■ 15 A	P4.2 ▣ 13 A	P4.3 ▣ 10 A	M1.1 ▣ 30 A	M1.2 ▣ 26 A
M2.1 ▣ 27 A	M2.2 ▣ 22 A	M3.1 ▣ 12 A	M3.2 ▣ 10 A	M3.3 ▣ 9 A	M4.1 ▣ 15 A	K1.1 ■ 30 A	K1.2 ■ 22 A	K1.3 ■ 17 A	K2.1 ▣ 25 A	K2.2 ▣ 20 A	K2.3 ▣ 16 A	K3.1 ▣ 22 A	K3.2 ▣ 17 A
K3.3 ▣ 13 A	K4.1 ▣ 20 A	K4.2 ▣ 15 A	K4.3 ▣ 11 A	K4.4 ▣ 10 A	K4.5 ▣ 8 A	K5.1 ▣ 23 A	K5.2 ▣ 17 A	K5.3 ▣ 13 A	N1.1 ▣ 35 A	N1.2 ▣ 26 A	N1.3 ▣ 18 A	N2.1 ▣ 42 A	N2.2 ▣ 37 A
N2.3 ▣ 27 A	N3.1 ▣ 68 A	N3.2 ▣ 40 A	N3.3 ▣ 20 A	N4.1 ▣ 48 A	N4.2 ▣ 25 A	S1.1 ▣ 23 A	S1.2 ▣ 17 A	S1.3 ▣ 8 A	S2.1 ▣ 9 A	S2.2 ▣ 6 A	S3.1 ▣ 7 A	S3.2 ▣ 4 A	S4.1 ▣ 5 A
S4.2 ▣ 3 A													

Product	DC (mm)	DC (inch)	LCF (mm)	OAL (mm)	DCON MS (mm)
A720.15	0.15	0.0059	1.0	25.0	1.00
A720.18	0.18	0.0070	1.4	25.0	1.00
A720.2	0.20	0.0079	1.8	25.0	1.00
A720.22	0.22	0.0087	1.8	25.0	1.00
A720.25	0.25	0.0098	2.2	25.0	1.00
A720.27	0.27	0.0106	2.2	25.0	1.00
A720.28	0.28	0.0110	2.2	25.0	1.00
A720.3	0.30	0.0118	2.2	25.0	1.00
A720.35	0.35	0.0138	2.8	25.0	1.00
A720.4	0.40	0.0157	3.6	25.0	1.00
A720.45	0.45	0.0177	3.6	25.0	1.00
A720.5	0.50	0.0197	4.0	25.0	1.00
A720.55	0.55	0.0217	4.5	25.0	1.00

Product	DC (mm)	DC (inch)	LCF (mm)	OAL (mm)	DCON MS (mm)
A720.6	0.60	0.0236	4.5	25.0	1.00
A720.62	0.62	0.0244	5.0	25.0	1.00
A720.65	0.65	0.0256	5.0	25.0	1.00
A720.7	0.70	0.0276	5.6	25.0	1.00
A720.75	0.75	0.0295	5.6	25.0	1.00
A720.8	0.80	0.0315	6.3	25.0	1.50
A720.85	0.85	0.0335	6.3	25.0	1.50
A720.9	0.90	0.0354	7.1	25.0	1.50
A720.95	0.95	0.0374	7.1	25.0	1.50
A7201.0	1.00	0.0394	8.0	25.0	1.50
A7201.05	1.05	0.0413	8.0	25.0	1.50
A7201.3	1.30	0.0512	10.0	25.0	1.50
A7201.4	1.40	0.0551	11.2	25.0	1.50

A520



Foret extra-court ADX en HSS, revêtement TiN

Foret haute performance capable de produire des trous de haute qualité et précis à des vitesses et des avances élevées (tolérance de trou H9). Sa pointe amincie à 130° facilite l'auto-centrage et réduit les efforts de coupe. Ce foret doit être utilisé sur des machines CNC uniquement. Le revêtement TiN prolonge la durée de vie de l'outil.

ADX

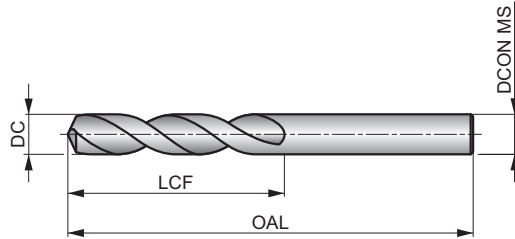

HSS	DIN 1897	2.5xD
130°	TiN	
λ 32-40°	R	DC h8

Adéquation du groupe de matériaux de la pièce, valeurs de départ pour la vitesse de coupe (m/min) et code Alpha d'avance. Les tableaux d'avances par tour se trouvent à partir de la page 274.

P1.1 ■ 53 M	P1.2 ■ 59 M	P1.3 ■ 61 M	P2.1 ■ 45 M	P2.2 ■ 40 K	P2.3 ■ 35 G	P3.1 ■ 31 I	P3.2 ■ 25 I	P3.3 ■ 21 G	P4.1 ■ 19 I	P4.2 ■ 16 G	P4.3 ■ 13 E	M1.1 ■ 41 I	M1.2 ■ 35 I
M2.1 ■ 37 I	M2.2 ■ 30 I	M3.1 ■ 19 I	M3.2 ■ 16 I	M3.3 ■ 14 I	M4.1 ■ 20 G	K1.1 ■ 48 M	K1.2 ■ 36 K	K1.3 ■ 27 K	K2.1 ■ 37 J	K2.2 ■ 30 J	K2.3 ■ 24 F	K3.1 ■ 33 J	K3.2 ■ 25 J
K3.3 ■ 20 F	K4.1 ■ 30 J	K4.2 ■ 23 J	K4.3 ■ 17 F	K4.4 ■ 14 F	K4.5 ■ 12 F	K5.1 ■ 34 J	K5.2 ■ 26 J	K5.3 ■ 20 F	N1.1 ■ 55 I	N1.2 ■ 41 I	N1.3 ■ 28 M	N2.1 ■ 57 K	N2.2 ■ 51 K
N2.3 ■ 37 K	N3.1 ■ 85 K	N3.2 ■ 50 I	N3.3 ■ 25 E	N4.1 ■ 65 G	N4.2 ■ 50 G	N4.3 ■ 35 F	S1.1 ■ 34 I	S1.2 ■ 20 G	S1.3 ■ 4 B	S2.1 ■ 15 G	S2.2 ■ 10 E	S3.1 ■ 11 G	S3.2 ■ 7 E
S4.1 ■ 19 G	S4.2 ■ 16 E												

Product	DC (inch)	DC (mm)	DC (inch)	LCF (mm)	OAL (mm)	DCON MS (mm)
A5203.0	-	3.00	0.1181	16.0	46.0	3.00
A5203.1	-	3.10	0.1220	18.0	49.0	3.10
A5201/8	1/8	3.18	0.1250	18.0	49.0	3.18
A5203.2	-	3.20	0.1260	18.0	49.0	3.20
A5203.3	-	3.30	0.1299	18.0	49.0	3.30
A5203.4	-	3.40	0.1339	20.0	52.0	3.40
A5203.5	-	3.50	0.1378	20.0	52.0	3.50
A5203.6	-	3.60	0.1417	20.0	52.0	3.60
A5203.7	-	3.70	0.1457	20.0	52.0	3.70
A5203.8	-	3.80	0.1496	22.0	55.0	3.80
A5203.9	-	3.90	0.1535	22.0	55.0	3.90
A5204.0	-	4.00	0.1575	22.0	55.0	4.00
A5204.1	-	4.10	0.1614	22.0	55.0	4.10
A5204.2	-	4.20	0.1654	22.0	55.0	4.20
A5204.3	-	4.30	0.1693	24.0	58.0	4.30
A52011/64	11/64	4.37	0.1719	24.0	58.0	4.37
A5204.4	-	4.40	0.1732	24.0	58.0	4.40
A5204.5	-	4.50	0.1772	24.0	58.0	4.50
A5204.6	-	4.60	0.1811	24.0	58.0	4.60
A5204.7	-	4.70	0.1850	24.0	58.0	4.70
A5203/16	3/16	4.76	0.1875	26.0	62.0	4.76
A5204.8	-	4.80	0.1890	26.0	62.0	4.80
A5204.9	-	4.90	0.1929	26.0	62.0	4.90
A5205.0	-	5.00	0.1969	26.0	62.0	5.00

Product	DC (inch)	DC (mm)	DC (inch)	LCF (mm)	OAL (mm)	DCON MS (mm)
A5205.1	-	5.10	0.2008	26.0	62.0	5.10
A5205.2	-	5.20	0.2047	26.0	62.0	5.20
A5205.3	-	5.30	0.2087	26.0	62.0	5.30
A5205.4	-	5.40	0.2126	28.0	66.0	5.40
A5205.5	-	5.50	0.2165	28.0	66.0	5.50
A5207/32	7/32	5.56	0.2188	28.0	66.0	5.56
A5205.6	-	5.60	0.2205	28.0	66.0	5.60
A5205.7	-	5.70	0.2244	28.0	66.0	5.70
A5205.8	-	5.80	0.2283	28.0	66.0	5.80
A5205.9	-	5.90	0.2323	28.0	66.0	5.90
A5206.0	-	6.00	0.2362	28.0	66.0	6.00
A5206.1	-	6.10	0.2402	31.0	70.0	6.10
A5206.2	-	6.20	0.2441	31.0	70.0	6.20
A5206.3	-	6.30	0.2480	31.0	70.0	6.30
A5201/4	1/4	6.35	0.2500	31.0	70.0	6.35
A5206.4	-	6.40	0.2520	31.0	70.0	6.40
A5206.5	-	6.50	0.2559	31.0	70.0	6.50
A5206.6	-	6.60	0.2598	31.0	70.0	6.60
A5206.7	-	6.70	0.2638	31.0	70.0	6.70
A52017/64	17/64	6.75	0.2656	34.0	74.0	6.75
A5206.8	-	6.80	0.2677	34.0	74.0	6.80
A5206.9	-	6.90	0.2717	34.0	74.0	6.90
A5207.0	-	7.00	0.2756	34.0	74.0	7.00
A5207.1	-	7.10	0.2795	34.0	74.0	7.10

Product	DC	DC	DC	LCF	OAL	D CON MS
	(inch)	(mm)	(inch)	(mm)	(mm)	(mm)
A5209/32	9/32	7.14	0.2813	34.0	74.0	7.14
A5207.2	–	7.20	0.2835	34.0	74.0	7.20
A5207.4	–	7.40	0.2913	34.0	74.0	7.40
A5207.5	–	7.50	0.2953	34.0	74.0	7.50
A5207.8	–	7.80	0.3071	37.0	79.0	7.80
A5207.9	–	7.90	0.3110	37.0	79.0	7.90
A5205/16	5/16	7.94	0.3125	37.0	79.0	7.94
A5208.0	–	8.00	0.3150	37.0	79.0	8.00
A5208.1	–	8.10	0.3189	37.0	79.0	8.10
A5208.2	–	8.20	0.3228	37.0	79.0	8.20
A5208.3	–	8.30	0.3268	37.0	79.0	8.30
A5208.4	–	8.40	0.3307	37.0	79.0	8.40
A5208.5	–	8.50	0.3346	37.0	79.0	8.50
A5208.6	–	8.60	0.3386	40.0	84.0	8.60
A5208.7	–	8.70	0.3425	40.0	84.0	8.70
A52011/32	11/32	8.73	0.3438	40.0	84.0	8.73
A5208.8	–	8.80	0.3465	40.0	84.0	8.80
A5209.0	–	9.00	0.3543	40.0	84.0	9.00
A5209.1	–	9.10	0.3583	40.0	84.0	9.10
A5209.5	–	9.50	0.3740	40.0	84.0	9.50
A5203/8	3/8	9.52	0.3750	43.0	89.0	9.52
A5209.6	–	9.60	0.3780	43.0	89.0	9.60
A5209.7	–	9.70	0.3819	43.0	89.0	9.70
A52025/64	25/64	9.92	0.3906	43.0	89.0	9.92

Product	DC	DC	DC	LCF	OAL	D CON MS
	(inch)	(mm)	(inch)	(mm)	(mm)	(mm)
A52010.0	–	10.00	0.3937	43.0	89.0	10.00
A52010.1	–	10.10	0.3976	43.0	89.0	10.10
A52010.2	–	10.20	0.4016	43.0	89.0	10.20
A52010.3	–	10.30	0.4055	43.0	89.0	10.30
A52013/32	13/32	10.32	0.4063	43.0	89.0	10.32
A52010.5	–	10.50	0.4134	43.0	89.0	10.50
A52027/64	27/64	10.72	0.4219	47.0	95.0	10.72
A52010.8	–	10.80	0.4252	47.0	95.0	10.80
A52011.0	–	11.00	0.4331	47.0	95.0	11.00
A52011.1	–	11.10	0.4370	47.0	95.0	11.10
A5207/16	7/16	11.11	0.4375	47.0	95.0	11.11
A52011.3	–	11.30	0.4449	47.0	95.0	11.30
A52011.5	–	11.50	0.4528	47.0	95.0	11.50
A52011.7	–	11.70	0.4606	47.0	95.0	11.70
A52011.8	–	11.80	0.4646	47.0	95.0	11.80
A52012.0	–	12.00	0.4724	51.0	102.0	12.00
A52012.1	–	12.10	0.4764	51.0	102.0	12.10
A52012.2	–	12.20	0.4803	51.0	102.0	12.20
A52031/64	31/64	12.30	0.4844	51.0	102.0	12.30
A52012.5	–	12.50	0.4921	51.0	102.0	12.50
A5201/2	1/2	12.70	0.5000	51.0	102.0	12.70
A52012.8	–	12.80	0.5039	51.0	102.0	12.80
A52013.0	–	13.00	0.5118	51.0	102.0	13.00

A620

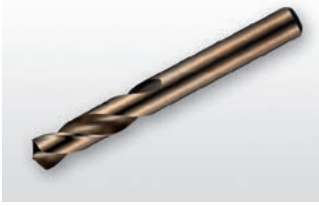

Foret extra-court en HSS-E (5% cobalt), finition bronze

Foret avec un angle de pointe à 130° qui facilite l'auto-centrage et réduit les forces de coupe. La finition avec traitement bronze est une fine couche d'oxyde et c'est une indication pour le cobalt. Convient pour percer de nombreux matériaux. Ne doit pas être utilisé dans des appareils portatifs.

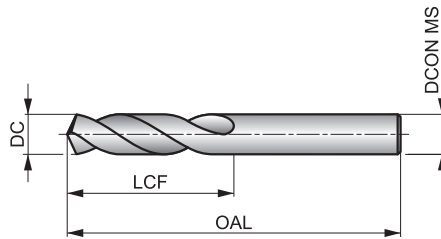

HSS-E	DIN 1897	2.5xD
130°	Bronze	
λ 20-35°	R	DC h8

Adéquation du groupe de matériaux de la pièce, valeurs de départ pour la vitesse de coupe (m/min) et code Alpha d'avance. Les tableaux d'avances par tour se trouvent à partir de la page 274.

P1.1 ■40 H	P1.2 ■45 H	P1.3 ■46 H	P2.1 ■34 H	P2.2 ■30 G	P2.3 ■27 F	P3.1 ■27 G	P3.2 ■21 G	P3.3 ■18 F	P4.1 ■16 G	P4.2 ■13 F	P4.3 ■11 E	M1.1 ■30 F	M1.2 ■26 F
M2.1 ■27 F	M2.2 ■22 F	M3.1 ■13 H	M3.2 ■11 H	M3.3 ■10 H	M4.1 ■15 D	K1.1 ■34 K	K1.2 ■25 F	K1.3 ■19 F	K2.1 ■27 F	K2.2 ■22 F	K2.3 ■18 F	K3.1 ■24 F	K3.2 ■18 F
K3.3 ■15 F	K4.1 ■22 F	K4.2 ■17 F	K4.3 ■12 F	K4.4 ■11 F	K4.5 ■9 F	K5.1 ■25 F	K5.2 ■19 F	K5.3 ■15 F	N1.1 ■40 K	N1.2 ■30 K	N1.3 ■20 J	N2.1 ■49 I	N2.2 ■44 I
N2.3 ■32 I	N3.1 ■68 J	N3.2 ■40 K	N3.3 ■20 I	N4.1 ■40 L	N4.2 ■32 K	N4.3 ■18 I	S1.1 ■30 G	S1.2 ■18 F	S1.3 ■10 C	S2.1 ■12 F	S2.2 ■8 C	S3.1 ■9 F	S3.2 ■6 C
S4.1 ■7 F	S4.2 ■5 C												

Product	DC (mm)	DC (inch)	LCF (mm)	OAL (mm)	DCON MS (mm)
A6202.5	2.50	0.0984	14.0	43.0	2.50
A6202.6	2.60	0.1024	14.0	43.0	2.60
A6202.7	2.70	0.1063	16.0	46.0	2.70
A6202.8	2.80	0.1102	16.0	46.0	2.80
A6202.9	2.90	0.1142	16.0	46.0	2.90
A6203.0	3.00	0.1181	16.0	46.0	3.00
A6203.1	3.10	0.1220	18.0	49.0	3.10
A6203.2	3.20	0.1260	18.0	49.0	3.20
A6203.3	3.30	0.1299	18.0	49.0	3.30
A6203.4	3.40	0.1339	20.0	52.0	3.40
A6203.5	3.50	0.1378	20.0	52.0	3.50
A6204.0	4.00	0.1575	22.0	55.0	4.00
A6204.1	4.10	0.1614	22.0	55.0	4.10
A6204.2	4.20	0.1654	22.0	55.0	4.20
A6204.3	4.30	0.1693	24.0	58.0	4.30
A6204.5	4.50	0.1772	24.0	58.0	4.50
A6204.7	4.70	0.1850	24.0	58.0	4.70
A6204.9	4.90	0.1929	26.0	62.0	4.90
A6205.0	5.00	0.1969	26.0	62.0	5.00
A6205.1	5.10	0.2008	26.0	62.0	5.10
A6205.2	5.20	0.2047	26.0	62.0	5.20
A6205.3	5.30	0.2087	26.0	62.0	5.30
A6205.5	5.50	0.2165	28.0	66.0	5.50
A6205.6	5.60	0.2205	28.0	66.0	5.60
A6206.0	6.00	0.2362	28.0	66.0	6.00

Product	DC (mm)	DC (inch)	LCF (mm)	OAL (mm)	DCON MS (mm)
A6206.2	6.20	0.2441	31.0	70.0	6.20
A6206.3	6.30	0.2480	31.0	70.0	6.30
A6206.5	6.50	0.2559	31.0	70.0	6.50
A6206.8	6.80	0.2677	34.0	74.0	6.80
A6206.9	6.90	0.2717	34.0	74.0	6.90
A6207.0	7.00	0.2756	34.0	74.0	7.00
A6207.5	7.50	0.2953	34.0	74.0	7.50
A6207.8	7.80	0.3071	37.0	79.0	7.80
A6208.0	8.00	0.3150	37.0	79.0	8.00
A6208.2	8.20	0.3228	37.0	79.0	8.20
A6208.5	8.50	0.3346	37.0	79.0	8.50
A6208.7	8.70	0.3425	40.0	84.0	8.70
A6209.0	9.00	0.3543	40.0	84.0	9.00
A6209.5	9.50	0.3740	40.0	84.0	9.50
A62010.0	10.00	0.3937	43.0	89.0	10.00
A62010.2	10.20	0.4016	43.0	89.0	10.20
A62010.3	10.30	0.4055	43.0	89.0	10.30
A62010.5	10.50	0.4134	43.0	89.0	10.50
A62010.8	10.80	0.4252	47.0	95.0	10.80
A62011.0	11.00	0.4331	47.0	95.0	11.00
A62011.5	11.50	0.4528	47.0	95.0	11.50
A62012.0	12.00	0.4724	51.0	102.0	12.00
A62012.5	12.50	0.4921	51.0	102.0	12.50
A62013.0	13.00	0.5118	51.0	102.0	13.00

A117



Foret extra-court en HSS-E (8% cobalt), finition bronze

Foret recommandé pour une utilisation dans des matériaux et des applications difficiles. sa pointe à 135° avec affûtage en croix facilite l'auto-centrage et réduit également les forces de coupe. Fiable pour produire un trou précis et une finition de qualité. La finition avec traitement bronze est une fine couche d'oxyde et c'est une indication pour le cobalt.

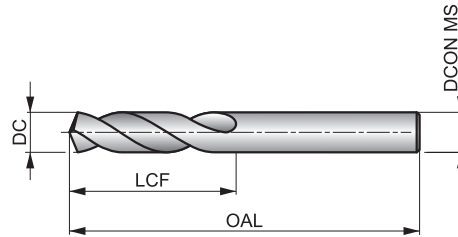

HSS-E	DIN 1897	2.5xD
135°	Bronze	
λ 20-35°	R	DC h8

Adéquation du groupe de matériaux de la pièce, valeurs de départ pour la vitesse de coupe (m/min) et code Alpha d'avance. Les tableaux d'avances par tour se trouvent à partir de la page 274.

P1.1 ■ 40 H	P1.2 ■ 45 H	P1.3 ■ 46 H	P2.1 ■ 34 H	P2.2 ■ 30 G	P2.3 ■ 27 F	P3.1 ■ 27 G	P3.2 ■ 21 G	P3.3 ■ 18 F	P4.1 ■ 16 G	P4.2 ■ 13 F	P4.3 ■ 11 E	M1.1 ■ 30 F	M1.2 ■ 26 F
M2.1 ■ 27 F	M2.2 ■ 22 F	M3.1 ■ 13 H	M3.2 ■ 11 H	M3.3 ■ 10 H	M4.1 ■ 15 D	K1.1 ■ 34 K	K1.2 ■ 25 F	K1.3 ■ 19 F	K2.1 ■ 27 F	K2.2 ■ 22 F	K2.3 ■ 18 F	K3.1 ■ 24 F	K3.2 ■ 18 F
K3.3 ■ 15 F	K4.1 ■ 22 F	K4.2 ■ 17 F	K4.3 ■ 12 F	K4.4 ■ 11 F	K4.5 ■ 9 F	K5.1 ■ 25 F	K5.2 ■ 19 F	K5.3 ■ 15 F	N1.1 ■ 35 K	N1.2 ■ 26 K	N1.3 ■ 18 J	N2.1 ■ 48 I	N2.2 ■ 43 I
N2.3 ■ 31 I	N3.1 ■ 68 J	N3.2 ■ 40 K	N3.3 ■ 20 I	N4.1 ■ 35 M	N4.2 ■ 28 K	N4.3 ■ 17 I	S1.1 ■ 30 G	S1.2 ■ 18 F	S1.3 ■ 10 C	S2.1 ■ 12 F	S2.2 ■ 8 C	S3.1 ■ 9 F	S3.2 ■ 6 C
S4.1 ■ 7 F	S4.2 ■ 5 C												

DC <= 1.5mm avec pointe 118°; DC < 3.00 mm 5% cobalt.

Product	DC (inch)	DC (mm)	DC (inch)	LCF (mm)	OAL (mm)	DCON MS (mm)
A1171.0	-	1.00	0.0394	6.0	26.0	1.00
A1171.1	-	1.10	0.0433	7.0	28.0	1.10
A1171.2	-	1.20	0.0472	8.0	30.0	1.20
A1171.3	-	1.30	0.0512	8.0	30.0	1.30
A1171.4	-	1.40	0.0551	9.0	32.0	1.40
A1171.5	-	1.50	0.0591	9.0	32.0	1.50
A1171.6	-	1.60	0.0630	10.0	34.0	1.60
A1171.7	-	1.70	0.0669	10.0	34.0	1.70
A1171.8	-	1.80	0.0709	11.0	36.0	1.80
A1171.9	-	1.90	0.0748	11.0	36.0	1.90
A1172.0	-	2.00	0.0787	12.0	38.0	2.00
A1172.1	-	2.10	0.0827	12.0	38.0	2.10
A1172.2	-	2.20	0.0866	13.0	40.0	2.20
A1172.3	-	2.30	0.0906	13.0	40.0	2.30
A1172.4	-	2.40	0.0945	14.0	43.0	2.40
A1172.5	-	2.50	0.0984	14.0	43.0	2.50
A1172.6	-	2.60	0.1024	14.0	43.0	2.60
A1172.7	-	2.70	0.1063	16.0	46.0	2.70
A1172.8	-	2.80	0.1102	16.0	46.0	2.80
A1172.9	-	2.90	0.1142	16.0	46.0	2.90
A1173.0	-	3.00	0.1181	16.0	46.0	3.00
A1173.1	-	3.10	0.1220	18.0	49.0	3.10
A1171/8	1/8	3.18	0.1250	18.0	49.0	3.18

Product	DC (inch)	DC (mm)	DC (inch)	LCF (mm)	OAL (mm)	DCON MS (mm)
A1173.2	-	3.20	0.1260	18.0	49.0	3.20
A1173.3	-	3.30	0.1299	18.0	49.0	3.30
A1173.4	-	3.40	0.1339	20.0	52.0	3.40
A1173.5	-	3.50	0.1378	20.0	52.0	3.50
A1173.6	-	3.60	0.1417	20.0	52.0	3.60
A1173.7	-	3.70	0.1457	20.0	52.0	3.70
A1173.8	-	3.80	0.1496	22.0	55.0	3.80
A1173.9	-	3.90	0.1535	22.0	55.0	3.90
A1175/32	5/32	3.97	0.1563	22.0	55.0	3.97
A1174.0	-	4.00	0.1575	22.0	55.0	4.00
A1174.1	-	4.10	0.1614	22.0	55.0	4.10
A1174.2	-	4.20	0.1654	22.0	55.0	4.20
A1174.3	-	4.30	0.1693	24.0	58.0	4.30
A1174.4	-	4.40	0.1732	24.0	58.0	4.40
A1174.5	-	4.50	0.1772	24.0	58.0	4.50
A1174.6	-	4.60	0.1811	24.0	58.0	4.60
A1174.7	-	4.70	0.1850	24.0	58.0	4.70
A1173/16	3/16	4.76	0.1875	26.0	62.0	4.76
A1174.8	-	4.80	0.1890	26.0	62.0	4.80
A1174.9	-	4.90	0.1929	26.0	62.0	4.90
A1175.0	-	5.00	0.1969	26.0	62.0	5.00
A1175.1	-	5.10	0.2008	26.0	62.0	5.10
A1175.2	-	5.20	0.2047	26.0	62.0	5.20

Product	DC	DC	DC	LCF	OAL	D CON MS
	(inch)	(mm)	(inch)	(mm)	(mm)	(mm)
A1175.3	–	5.30	0.2087	26.0	62.0	5.30
A1175.4	–	5.40	0.2126	28.0	66.0	5.40
A1175.5	–	5.50	0.2165	28.0	66.0	5.50
A1175.6	–	5.60	0.2205	28.0	66.0	5.60
A1175.7	–	5.70	0.2244	28.0	66.0	5.70
A1175.8	–	5.80	0.2283	28.0	66.0	5.80
A1175.9	–	5.90	0.2323	28.0	66.0	5.90
A1176.0	–	6.00	0.2362	28.0	66.0	6.00
A1176.1	–	6.10	0.2402	31.0	70.0	6.10
A1176.2	–	6.20	0.2441	31.0	70.0	6.20
A1176.3	–	6.30	0.2480	31.0	70.0	6.30
A1171/4	1/4	6.35	0.2500	31.0	70.0	6.35
A1176.4	–	6.40	0.2520	31.0	70.0	6.40
A1176.5	–	6.50	0.2559	31.0	70.0	6.50
A1176.6	–	6.60	0.2598	31.0	70.0	6.60
A1176.7	–	6.70	0.2638	31.0	70.0	6.70
A1176.8	–	6.80	0.2677	34.0	74.0	6.80
A1176.9	–	6.90	0.2717	34.0	74.0	6.90
A1177.0	–	7.00	0.2756	34.0	74.0	7.00
A1177.1	–	7.10	0.2795	34.0	74.0	7.10
A1177.2	–	7.20	0.2835	34.0	74.0	7.20
A1177.3	–	7.30	0.2874	34.0	74.0	7.30
A1177.4	–	7.40	0.2913	34.0	74.0	7.40
A1177.5	–	7.50	0.2953	34.0	74.0	7.50
A1177.6	–	7.60	0.2992	37.0	79.0	7.60
A1177.7	–	7.70	0.3031	37.0	79.0	7.70
A1177.8	–	7.80	0.3071	37.0	79.0	7.80

Product	DC	DC	DC	LCF	OAL	D CON MS
	(inch)	(mm)	(inch)	(mm)	(mm)	(mm)
A1177.9	–	7.90	0.3110	37.0	79.0	7.90
A1175/16	5/16	7.94	0.3125	37.0	79.0	7.94
A1178.0	–	8.00	0.3150	37.0	79.0	8.00
A1178.1	–	8.10	0.3189	37.0	79.0	8.10
A1178.2	–	8.20	0.3228	37.0	79.0	8.20
A1178.3	–	8.30	0.3268	37.0	79.0	8.30
A1178.4	–	8.40	0.3307	37.0	79.0	8.40
A1178.5	–	8.50	0.3346	37.0	79.0	8.50
A1178.6	–	8.60	0.3386	40.0	84.0	8.60
A1178.7	–	8.70	0.3425	40.0	84.0	8.70
A1178.8	–	8.80	0.3465	40.0	84.0	8.80
A1178.9	–	8.90	0.3504	40.0	84.0	8.90
A1179.0	–	9.00	0.3543	40.0	84.0	9.00
A1179.1	–	9.10	0.3583	40.0	84.0	9.10
A1179.2	–	9.20	0.3622	40.0	84.0	9.20
A1179.3	–	9.30	0.3661	40.0	84.0	9.30
A1179.5	–	9.50	0.3740	40.0	84.0	9.50
A1179.9	–	9.90	0.3898	43.0	89.0	9.90
A11710.0	–	10.00	0.3937	43.0	89.0	10.00
A11710.2	–	10.20	0.4016	43.0	89.0	10.20
A11710.5	–	10.50	0.4134	43.0	89.0	10.50
A11711.0	–	11.00	0.4331	47.0	95.0	11.00
A11711.5	–	11.50	0.4528	47.0	95.0	11.50
A11712.0	–	12.00	0.4724	51.0	102.0	12.00
A1171/2	1/2	12.70	0.5000	51.0	102.0	12.70
A11713.0	–	13.00	0.5118	51.0	102.0	13.00

A920



Foret extra-court PFX en HSS-E (5% cobalt), finition brillante

Foret haute performance capable de produire des trous de haute qualité et précis à des vitesses et des avances élevées (tolérance de trou H10). Sa pointe auto-centrante à 130° et la conception spéciale de sa goujure parabolique permettent de percer des trous profonds en une seule passe. Convient à de nombreux matériaux.

PFX

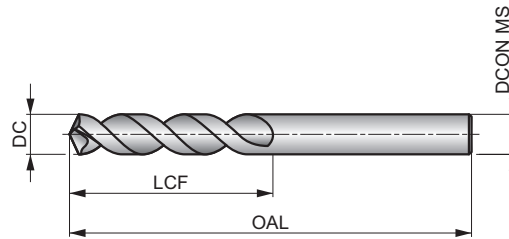

HSS-E	DIN ANSI	3×D
130°	Bright	
λ>35°	R	DC h8

Adéquation du groupe de matériaux de la pièce, valeurs de départ pour la vitesse de coupe (m/min) et code Alpha d'avance. Les tableaux d'avances par tour se trouvent à partir de la page 274.

P1.1 ■ 42 J	P1.2 ■ 47 J	P1.3 ■ 49 J	P2.1 ■ 36 J	P2.2 ■ 32 I	P2.3 ■ 28 E	P3.1 ■ 34 I	P3.2 ■ 27 I	P3.3 ■ 23 E	P4.1 ■ 20 I	P4.2 ■ 17 E	P4.3 ■ 14 E	M1.1 ■ 21 F	M1.2 ■ 17 F
M2.1 ■ 18 F	M2.2 ■ 15 F	M3.1 ■ 8 F	M3.2 ■ 7 F	M3.3 ■ 6 F	M4.1 ■ 9 D	K1.1 ■ 34 L	K1.2 ■ 25 L	K1.3 ■ 19 L	K2.1 ■ 32 L	K2.2 ■ 26 L	K2.3 ■ 21 J	K3.1 ■ 28 L	K3.2 ■ 22 L
K3.3 ■ 17 J	K4.1 ■ 26 L	K4.2 ■ 20 L	K4.3 ■ 14 J	K4.4 ■ 12 J	K4.5 ■ 10 J	K5.1 ■ 30 L	K5.2 ■ 22 L	K5.3 ■ 17 J	N1.1 ■ 75 L	N1.2 ■ 56 L	N1.3 ■ 38 N	N2.1 ■ 62 N	N2.2 ■ 55 N
N2.3 ■ 40 N	N3.1 ■ 112 J	N3.2 ■ 66 J	N3.3 ■ 33 H	N4.1 ■ 55 J	N4.2 ■ 40 H	S1.1 ■ 30 G	S1.2 ■ 18 G	S1.3 ■ 10 C	S2.1 ■ 12 G	S2.2 ■ 8 E	S3.1 ■ 9 G	S3.2 ■ 6 E	S4.1 ■ 7 G
S4.2 ■ 5 E													

Product	DC (inch)	DC (mm)	DC (inch)	LCF (mm)	OAL (mm)	DCON MS (mm)
A9201.0	–	1.00	0.0394	6.0	26.0	1.00
A9203/64	3/64	1.19	0.0469	13.0	35.0	1.19
A9201.2	–	1.20	0.0472	8.0	30.0	1.20
A9201.25	–	1.25	0.0492	8.0	30.0	1.25
A9201.3	–	1.30	0.0512	8.0	30.0	1.30
A9201.35	–	1.35	0.0531	9.0	32.0	1.35
A9201.4	–	1.40	0.0551	9.0	32.0	1.40
A9201.5	–	1.50	0.0591	9.0	32.0	1.50
A9201.55	–	1.55	0.0610	10.0	34.0	1.55
A9201/16	1/16	1.59	0.0625	16.0	41.0	1.59
A9201.6	–	1.60	0.0630	10.0	34.0	1.60
A9201.7	–	1.70	0.0669	10.0	34.0	1.70
A9201.8	–	1.80	0.0709	11.0	36.0	1.80
A9201.9	–	1.90	0.0748	11.0	36.0	1.90
A9205/64	5/64	1.98	0.0781	17.0	43.0	1.98
A9202.0	–	2.00	0.0787	12.0	38.0	2.00
A9202.1	–	2.10	0.0827	12.0	38.0	2.10
A9202.15	–	2.15	0.0846	13.0	40.0	2.15
A9202.2	–	2.20	0.0866	13.0	40.0	2.20
A9202.3	–	2.30	0.0906	13.0	40.0	2.30
A9202.35	–	2.35	0.0925	14.0	43.0	2.35
A9203/32	3/32	2.38	0.0938	19.0	41.0	2.38
A9202.4	–	2.40	0.0945	14.0	43.0	2.40
A9202.5	–	2.50	0.0984	14.0	43.0	2.50

Product	DC (inch)	DC (mm)	DC (inch)	LCF (mm)	OAL (mm)	DCON MS (mm)
A9202.6	–	2.60	0.1024	14.0	43.0	2.60
A9202.7	–	2.70	0.1063	16.0	46.0	2.70
A9207/64	7/64	2.78	0.1094	21.0	46.0	2.78
A9202.8	–	2.80	0.1102	16.0	46.0	2.80
A9202.9	–	2.90	0.1142	16.0	46.0	2.90
A9203.0	–	3.00	0.1181	16.0	46.0	3.00
A9203.1	–	3.10	0.1220	18.0	49.0	3.10
A9201/8	1/8	3.18	0.1250	22.0	48.0	3.18
A9203.2	–	3.20	0.1260	18.0	49.0	3.20
A9203.3	–	3.30	0.1299	18.0	49.0	3.30
A9203.4	–	3.40	0.1339	20.0	52.0	3.40
A9203.5	–	3.50	0.1378	20.0	52.0	3.50
A9209/64	9/64	3.57	0.1406	24.0	49.0	3.57
A9203.6	–	3.60	0.1417	20.0	52.0	3.60
A9203.7	–	3.70	0.1457	20.0	52.0	3.70
A9203.8	–	3.80	0.1496	22.0	55.0	3.80
A9205/32	5/32	3.97	0.1563	25.0	52.0	3.97
A9204.0	–	4.00	0.1575	22.0	55.0	4.00
A9204.1	–	4.10	0.1614	22.0	55.0	4.10
A9204.2	–	4.20	0.1654	22.0	55.0	4.20
A9204.3	–	4.30	0.1693	24.0	58.0	4.30
A92011/64	11/64	4.37	0.1719	27.0	54.0	4.37
A9204.4	–	4.40	0.1732	24.0	58.0	4.40
A9204.5	–	4.50	0.1772	24.0	58.0	4.50

Product	DC	DC	DC	LCF	OAL	D CON MS
	(inch)	(mm)	(inch)	(mm)	(mm)	(mm)
A9204.6	–	4.60	0.1811	24.0	58.0	4.60
A9203/16	3/16	4.76	0.1875	29.0	56.0	4.76
A9204.8	–	4.80	0.1890	26.0	62.0	4.80
A9204.9	–	4.90	0.1929	26.0	62.0	4.90
A9205.0	–	5.00	0.1969	26.0	62.0	5.00
A9205.1	–	5.10	0.2008	26.0	62.0	5.10
A92013/64	13/64	5.16	0.2031	30.0	57.0	5.16
A9205.2	–	5.20	0.2047	26.0	62.0	5.20
A9205.3	–	5.30	0.2087	26.0	62.0	5.30
A9205.4	–	5.40	0.2126	28.0	66.0	5.40
A9205.5	–	5.50	0.2165	28.0	66.0	5.50
A9207/32	7/32	5.56	0.2188	32.0	60.0	5.56
A9205.6	–	5.60	0.2205	28.0	66.0	5.60
A9205.7	–	5.70	0.2244	28.0	66.0	5.70
A9205.9	–	5.90	0.2323	28.0	66.0	5.90
A9206.0	–	6.00	0.2362	28.0	66.0	6.00
A9206.2	–	6.20	0.2441	31.0	70.0	6.20
A9201/4	1/4	6.35	0.2500	35.0	64.0	6.35
A9206.4	–	6.40	0.2520	31.0	70.0	6.40
A9206.5	–	6.50	0.2559	31.0	70.0	6.50
A9206.6	–	6.60	0.2598	31.0	70.0	6.60
A9206.7	–	6.70	0.2638	31.0	70.0	6.70
A92017/64	17/64	6.75	0.2656	37.0	67.0	6.75
A9206.8	–	6.80	0.2677	34.0	74.0	6.80
A9206.9	–	6.90	0.2717	34.0	74.0	6.90
A9207.0	–	7.00	0.2756	34.0	74.0	7.00
A9207.1	–	7.10	0.2795	34.0	74.0	7.10
A9209/32	9/32	7.14	0.2813	38.0	68.0	7.14
A9207.5	–	7.50	0.2953	34.0	74.0	7.50
A92019/64	19/64	7.54	0.2969	40.0	70.0	7.54
A9207.8	–	7.80	0.3071	37.0	79.0	7.80
A9205/16	5/16	7.94	0.3125	41.0	71.0	7.94
A9208.0	–	8.00	0.3150	37.0	79.0	8.00
A9208.3	–	8.30	0.3268	37.0	79.0	8.30

Product	DC	DC	DC	LCF	OAL	D CON MS
	(inch)	(mm)	(inch)	(mm)	(mm)	(mm)
A9208.4	–	8.40	0.3307	37.0	79.0	8.40
A9208.5	–	8.50	0.3346	37.0	79.0	8.50
A9208.6	–	8.60	0.3386	40.0	84.0	8.60
A9208.7	–	8.70	0.3425	40.0	84.0	8.70
A9209.0	–	9.00	0.3543	40.0	84.0	9.00
A9209.5	–	9.50	0.3740	40.0	84.0	9.50
A9203/8	3/8	9.52	0.3750	46.0	79.0	9.52
A92025/64	25/64	9.92	0.3906	48.0	83.0	9.92
A92010.0	–	10.00	0.3937	43.0	89.0	10.00
A92010.2	–	10.20	0.4016	43.0	89.0	10.20
A92010.3	–	10.30	0.4055	43.0	89.0	10.30
A92010.5	–	10.50	0.4134	43.0	89.0	10.50
A92027/64	27/64	10.72	0.4219	51.0	86.0	10.72
A92010.8	–	10.80	0.4252	47.0	95.0	10.80
A92011.0	–	11.00	0.4331	47.0	95.0	11.00
A9207/16	7/16	11.11	0.4375	52.0	87.0	11.11
A92011.5	–	11.50	0.4528	47.0	95.0	11.50
A92011.8	–	11.80	0.4646	47.0	95.0	11.80
A92012.0	–	12.00	0.4724	51.0	102.0	12.00
A92012.5	–	12.50	0.4921	51.0	102.0	12.50
A9201/2	1/2	12.70	0.5000	57.0	95.0	12.70
A92013.0	–	13.00	0.5118	51.0	102.0	13.00
A92014.0	–	14.00	0.5512	54.0	107.0	14.00
A92014.5	–	14.50	0.5709	56.0	111.0	14.50
A92016.0	–	16.00	0.6299	58.0	115.0	16.00
A92016.5	–	16.50	0.6496	60.0	119.0	16.50
A92021/32	21/32	16.67	0.6563	73.0	114.0	16.67
A92017.0	–	17.00	0.6693	60.0	119.0	17.00
A92017.5	–	17.50	0.6890	62.0	123.0	17.50
A92018.0	–	18.00	0.7087	62.0	123.0	18.00
A92023/32	23/32	18.26	0.7188	76.0	121.0	18.26
A92019.0	–	19.00	0.7480	64.0	127.0	19.00
A92025/32	25/32	19.84	0.7813	83.0	130.0	19.84
A92020.0	–	20.00	0.7874	66.0	131.0	20.00

R023



Foret extra-court en carbure monobloc, avec pointe revêtue TiN

Foret polyvalent d'entrée de gamme avec un angle de pointe de 120°. La géométrie de pointe à quatre facettes réduit la force de poussée et la construction de goujures CTW améliore les taux de pénétration. Le revêtement TiN de la pointe améliore les performances et prolonge la durée de vie de l'outil. Convient aux machines à commande numérique et conventionnelles pour une large gamme de matériaux de pièces à usiner.

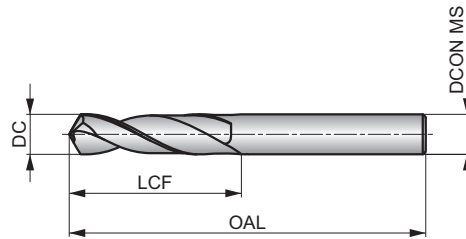

HM	DIN 6539	2.5xD
120°	TiN-Tip	
λ 20-35°	R	DC h7

Adéquation du groupe de matériaux de la pièce, valeurs de départ pour la vitesse de coupe (m/min) et code Alpha d'avance. Les tableaux d'avances par tour se trouvent à partir de la page 274.

P1.1 ■ 99 T	P1.2 ■ 111 T	P1.3 ■ 115 T	P2.1 ■ 85 T	P2.2 ■ 75 T	P2.3 ■ 66 T	P3.1 ■ 66 T	P3.2 ■ 53 T	P3.3 ■ 45 T	P4.1 ■ 40 S	P4.2 ■ 34 S	P4.3 ■ 27 S	K1.1 ■ 75 U	K1.2 ■ 56 U
K1.3 ■ 42 U	K2.1 ■ 68 U	K2.2 ■ 55 U	K2.3 ■ 44 U	K3.1 ■ 60 U	K3.2 ■ 46 U	K3.3 ■ 37 U	K4.1 ■ 55 T	K4.2 ■ 42 T	K4.3 ■ 31 T	K4.4 ■ 26 T	K4.5 ■ 22 T	K5.1 ■ 63 U	K5.2 ■ 47 U
K5.3 ■ 37 U	N1.1 ■ 150 W	N1.2 ■ 113 W	N1.3 ■ 75 W	N2.1 ■ 129 W	N2.2 ■ 116 W	N2.3 ■ 84 W	N3.1 ■ 317 W	N3.2 ■ 190 W	N4.1 ■ 60 V	N4.2 ■ 100 V	H1.1 ■ 34 S	H2.1 ■ 20 S	H3.1 ■ 22 S

Product	DC (mm)	DC (inch)	LCF (mm)	OAL (mm)	DCON MS (mm)
R0231.0	1.00	0.0394	6.0	26.0	1.00
R0231.1	1.10	0.0433	7.0	28.0	1.10
R0231.2	1.20	0.0472	8.0	30.0	1.20
R0231.3	1.30	0.0512	8.0	30.0	1.30
R0231.4	1.40	0.0551	9.0	32.0	1.40
R0231.5	1.50	0.0591	9.0	32.0	1.50
R0231.6	1.60	0.0630	10.0	34.0	1.60
R0231.7	1.70	0.0669	10.0	34.0	1.70
R0231.8	1.80	0.0709	11.0	36.0	1.80
R0231.9	1.90	0.0748	11.0	36.0	1.90
R0232.0	2.00	0.0787	12.0	38.0	2.00
R0232.1	2.10	0.0827	12.0	38.0	2.10
R0232.2	2.20	0.0866	13.0	40.0	2.20
R0232.3	2.30	0.0906	13.0	40.0	2.30
R0232.4	2.40	0.0945	14.0	43.0	2.40
R0232.5	2.50	0.0984	14.0	43.0	2.50
R0232.6	2.60	0.1024	14.0	43.0	2.60
R0232.7	2.70	0.1063	16.0	46.0	2.70
R0232.8	2.80	0.1102	16.0	46.0	2.80
R0232.9	2.90	0.1142	16.0	46.0	2.90
R0233.0	3.00	0.1181	16.0	46.0	3.00
R0233.1	3.10	0.1220	18.0	49.0	3.10
R0233.2	3.20	0.1260	18.0	49.0	3.20
R0233.3	3.30	0.1299	18.0	49.0	3.30
R0233.4	3.40	0.1339	20.0	52.0	3.40
R0233.5	3.50	0.1378	20.0	52.0	3.50
R0233.6	3.60	0.1417	20.0	52.0	3.60
R0233.7	3.70	0.1457	20.0	52.0	3.70

Product	DC (mm)	DC (inch)	LCF (mm)	OAL (mm)	DCON MS (mm)
R0233.8	3.80	0.1496	22.0	55.0	3.80
R0233.9	3.90	0.1535	22.0	55.0	3.90
R0234.0	4.00	0.1575	22.0	55.0	4.00
R0234.1	4.10	0.1614	22.0	55.0	4.10
R0234.2	4.20	0.1654	22.0	55.0	4.20
R0234.3	4.30	0.1693	24.0	58.0	4.30
R0234.4	4.40	0.1732	24.0	58.0	4.40
R0234.5	4.50	0.1772	24.0	58.0	4.50
R0234.6	4.60	0.1811	24.0	58.0	4.60
R0234.7	4.70	0.1850	24.0	58.0	4.70
R0234.8	4.80	0.1890	26.0	62.0	4.80
R0234.9	4.90	0.1929	26.0	62.0	4.90
R0235.0	5.00	0.1969	26.0	62.0	5.00
R0235.1	5.10	0.2008	26.0	62.0	5.10
R0235.2	5.20	0.2047	26.0	62.0	5.20
R0235.3	5.30	0.2087	26.0	62.0	5.30
R0235.4	5.40	0.2126	28.0	66.0	5.40
R0235.5	5.50	0.2165	28.0	66.0	5.50
R0235.6	5.60	0.2205	28.0	66.0	5.60
R0235.7	5.70	0.2244	28.0	66.0	5.70
R0235.8	5.80	0.2283	28.0	66.0	5.80
R0235.9	5.90	0.2323	28.0	66.0	5.90
R0236.0	6.00	0.2362	28.0	66.0	6.00
R0236.1	6.10	0.2402	31.0	70.0	6.10
R0236.2	6.20	0.2441	31.0	70.0	6.20
R0236.3	6.30	0.2480	31.0	70.0	6.30
R0236.4	6.40	0.2520	31.0	70.0	6.40
R0236.5	6.50	0.2559	31.0	70.0	6.50



Product	DC	DC	LCF	OAL	DCON MS
	(mm)	(inch)	(mm)	(mm)	(mm)
R0236.6	6.60	0.2598	31.0	70.0	6.60
R0236.7	6.70	0.2638	31.0	70.0	6.70
R0236.8	6.80	0.2677	34.0	74.0	6.80
R0236.9	6.90	0.2717	34.0	74.0	6.90
R0237.0	7.00	0.2756	34.0	74.0	7.00
R0237.1	7.10	0.2795	34.0	74.0	7.10
R0237.2	7.20	0.2835	34.0	74.0	7.20
R0237.3	7.30	0.2874	34.0	74.0	7.30
R0237.4	7.40	0.2913	34.0	74.0	7.40
R0237.5	7.50	0.2953	34.0	74.0	7.50
R0237.6	7.60	0.2992	37.0	79.0	7.60
R0237.7	7.70	0.3031	37.0	79.0	7.70
R0237.8	7.80	0.3071	37.0	79.0	7.80
R0237.9	7.90	0.3110	37.0	79.0	7.90
R0238.0	8.00	0.3150	37.0	79.0	8.00
R0238.1	8.10	0.3189	37.0	79.0	8.10
R0238.2	8.20	0.3228	37.0	79.0	8.20
R0238.3	8.30	0.3268	37.0	79.0	8.30
R0238.4	8.40	0.3307	37.0	79.0	8.40
R0238.5	8.50	0.3346	37.0	79.0	8.50

Product	DC	DC	LCF	OAL	DCON MS
	(mm)	(inch)	(mm)	(mm)	(mm)
R0238.6	8.60	0.3386	40.0	84.0	8.60
R0238.7	8.70	0.3425	40.0	84.0	8.70
R0238.8	8.80	0.3465	40.0	84.0	8.80
R0238.9	8.90	0.3504	40.0	84.0	8.90
R0239.0	9.00	0.3543	40.0	84.0	9.00
R0239.1	9.10	0.3583	40.0	84.0	9.10
R0239.2	9.20	0.3622	40.0	84.0	9.20
R0239.3	9.30	0.3661	40.0	84.0	9.30
R0239.4	9.40	0.3701	40.0	84.0	9.40
R0239.5	9.50	0.3740	40.0	84.0	9.50
R0239.6	9.60	0.3780	43.0	89.0	9.60
R0239.7	9.70	0.3819	43.0	89.0	9.70
R0239.8	9.80	0.3858	43.0	89.0	9.80
R0239.9	9.90	0.3898	43.0	89.0	9.90
R02310.0	10.00	0.3937	43.0	89.0	10.00
R02310.2	10.20	0.4016	43.0	89.0	10.20
R02310.5	10.50	0.4134	43.0	89.0	10.50
R02311.0	11.00	0.4331	47.0	95.0	11.00
R02311.5	11.50	0.4528	47.0	95.0	11.50
R02312.0	12.00	0.4724	51.0	102.0	12.00

Code de matériau du corps (BMC)	HSS-E	HSS-E	HSS	HSS-E	HM								
Groupe standard de base (BSG)	DIN 338	DIN 338	DIN 338	DORMER	DIN 338								
Rapport longueur utile diamètre (ULDR)	4xD	4xD	4xD	5xD	4xD								
Angle d'application	135°	130°	130°	130°	120°								
Revêtement	Bronze	Bright	TiN	TiAlN Top	TiN-Tip								
Queue				DIN 6335HA									
Forme de spirale	λ20-35°	VA	λ32-40°	λ>35°	λ20-35°								
Sens (direction de coupe)	R	R	R	R	R								
Propriété d'alimentation en liquide de coupe (CSP)													
			ADX	ADX									

Code de famille de produits		A777	A147	A510	A553	R003							
Plage de diamètres de coupe PSF		0.30 - 16.00	0.30 - 15.0	3.00 - 14.00	5.00 - 18.00	1.00 - 14.00							
		116	118	120	122	123							
P	P1	■	■	■	■	■							
	P2	■	■	■	■	■							
	P3	■	■	■	■	■							
	P4	■	■	■	■	■							
M	M1	■	■	■	■	■							
	M2	■	■	■	■	■							
	M3	■	■	■	■	■							
	M4	■	■	■	■	■							
K	K1	■	■	■	■	■							
	K2	■	■	■	■	■							
	K3	■	■	■	■	■							
	K4	■	■	■	■	■							
	K5	■	■	■	■	■							
N	N1	■	■	■	■	■							
	N2	■	■	■	■	■							
	N3	■	■	■	■	■							
	N4	■	■	■	■	■							
	N5	■	■	■	■	■							
S	S1	■	■	■	■	■							
	S2	■	■	■	■	■							
	S3	■	■	■	■	■							
	S4	■	■	■	■	■							
H	H1					■							
	H2					■							
	H3					■							
	H4					■							

A777



Foret court en HSS-E (8% cobalt), finition bronze

Foret performant produisant des trous de taille précise avec une finition de qualité dans des matériaux à haute résistance. Sa pointe avec affûtage en croix à 135° l'aide à se centrer automatiquement. La finition avec traitement bronze est une fine couche d'oxyde formée sur la surface de l'outil et indique un foret HSS-E à 8% de cobalt.

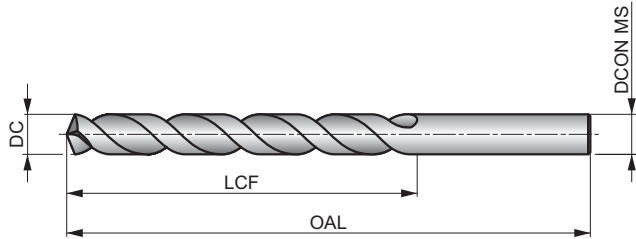

HSS-E	DIN 338	4×D
135°	Bronze	
λ 20-35°	R	DC h8

Adéquation du groupe de matériaux de la pièce, valeurs de départ pour la vitesse de coupe (m/min) et code Alpha d'avance. Les tableaux d'avances par tour se trouvent à partir de la page 274.

P1.1 ▣36 H	P1.2 ▣40 H	P1.3 ▣41 H	P2.1 ▣31 H	P2.2 ▣27 G	P2.3 ▣24 E	P3.1 ▣25 F	P3.2 ▣20 F	P3.3 ▣17 E	P4.1 ▣15 F	P4.2 ▣13 E	P4.3 ▣10 D	M1.1 ▣30 E	M1.2 ▣26 E
M2.1 ▣27 E	M2.2 ▣22 E	M3.1 ▣13 G	M3.2 ▣11 G	M3.3 ▣10 G	M4.1 ▣15 C	K1.1 ▣35 H	K1.2 ▣26 D	K1.3 ▣19 D	K2.1 ▣27 E	K2.2 ▣22 E	K2.3 ▣18 E	K3.1 ▣24 E	K3.2 ▣18 E
K3.3 ▣15 E	K4.1 ▣22 E	K4.2 ▣17 E	K4.3 ▣12 E	K4.4 ▣11 E	K4.5 ▣9 E	K5.1 ▣25 E	K5.2 ▣19 E	K5.3 ▣15 E	N1.1 ▣33 J	N1.2 ▣25 J	N1.3 ▣17 I	N2.1 ▣46 H	N2.2 ▣42 H
N2.3 ▣30 H	N3.1 ▣68 H	N3.2 ▣40 F	N3.3 ▣20 H	S1.1 ▣28 F	S1.2 ▣20 D	S1.3 ▣11 C	S2.1 ▣9 E	S2.2 ▣8 B	S3.1 ▣7 E	S3.2 ▣6 B	S4.1 ▣5 E	S4.2 ▣5 B	

NAS907J. DC ≤ 1.4mm avec pointe 4 facettes.

Les produits de cette série sont également disponibles en coffret. Voir A295.

Product	DC	DC	DC	LCF	OAL	DCON MS
	(inch)	(mm)	(inch)	(mm)	(mm)	(mm)
A777.3	–	0.30	0.0118	3.0	19.0	0.30
A777.35	–	0.35	0.0138	4.0	19.0	0.35
A777.4	–	0.40	0.0157	5.0	20.0	0.40
A777.45	–	0.45	0.0177	5.0	20.0	0.45
A777.5	–	0.50	0.0197	6.0	22.0	0.50
A777.55	–	0.55	0.0217	7.0	24.0	0.55
A777.6	–	0.60	0.0236	7.0	24.0	0.60
A777.65	–	0.65	0.0256	8.0	26.0	0.65
A777.7	–	0.70	0.0276	9.0	28.0	0.70
A777.8	–	0.80	0.0315	10.0	30.0	0.80
A777.9	–	0.90	0.0354	11.0	32.0	0.90
A777.95	–	0.95	0.0374	11.0	32.0	0.95
A7771.0	–	1.00	0.0394	12.0	34.0	1.00
A7771.1	–	1.10	0.0433	14.0	36.0	1.10
A7771.2	–	1.20	0.0472	16.0	38.0	1.20
A7771.3	–	1.30	0.0512	16.0	38.0	1.30
A7771.4	–	1.40	0.0551	18.0	40.0	1.40
A7771.5	–	1.50	0.0591	18.0	40.0	1.50
A7771/16	1/16	1.59	0.0625	20.0	43.0	1.59
A7771.6	–	1.60	0.0630	20.0	43.0	1.60
A7771.7	–	1.70	0.0669	20.0	43.0	1.70
A7771.8	–	1.80	0.0709	22.0	46.0	1.80
A7771.9	–	1.90	0.0748	22.0	46.0	1.90
A7775/64	5/64	1.98	0.0781	24.0	49.0	1.98

Product	DC	DC	DC	LCF	OAL	DCON MS
	(inch)	(mm)	(inch)	(mm)	(mm)	(mm)
A7772.0	–	2.00	0.0787	24.0	49.0	2.00
A7772.1	–	2.10	0.0827	24.0	49.0	2.10
A7772.2	–	2.20	0.0866	27.0	53.0	2.20
A7772.3	–	2.30	0.0906	27.0	53.0	2.30
A7773/32	3/32	2.38	0.0938	30.0	57.0	2.38
A7772.4	–	2.40	0.0945	30.0	57.0	2.40
A7772.5	–	2.50	0.0984	30.0	57.0	2.50
A7772.6	–	2.60	0.1024	30.0	57.0	2.60
A7772.7	–	2.70	0.1063	33.0	61.0	2.70
A7777/64	7/64	2.78	0.1094	33.0	61.0	2.78
A7772.8	–	2.80	0.1102	33.0	61.0	2.80
A7772.9	–	2.90	0.1142	33.0	61.0	2.90
A7773.0	–	3.00	0.1181	33.0	61.0	3.00
A7773.1	–	3.10	0.1220	36.0	65.0	3.10
A7771/8	1/8	3.18	0.1250	36.0	65.0	3.18
A7773.2	–	3.20	0.1260	36.0	65.0	3.20
A7773.3	–	3.30	0.1299	36.0	65.0	3.30
A7773.4	–	3.40	0.1339	39.0	70.0	3.40
A7773.5	–	3.50	0.1378	39.0	70.0	3.50
A7779/64	9/64	3.57	0.1406	39.0	70.0	3.57
A7773.6	–	3.60	0.1417	39.0	70.0	3.60
A7773.7	–	3.70	0.1457	39.0	70.0	3.70
A7773.8	–	3.80	0.1496	43.0	75.0	3.80
A7773.9	–	3.90	0.1535	43.0	75.0	3.90



Product	DC	DC	DC	LCF	OAL	D CON MS
	(inch)	(mm)	(inch)	(mm)	(mm)	(mm)
A7775/32	5/32	3.97	0.1563	43.0	75.0	3.97
A7774.0	–	4.00	0.1575	43.0	75.0	4.00
A7774.1	–	4.10	0.1614	43.0	75.0	4.10
A7774.2	–	4.20	0.1654	43.0	75.0	4.20
A7774.3	–	4.30	0.1693	47.0	80.0	4.30
A77711/64	11/64	4.37	0.1719	47.0	80.0	4.37
A7774.4	–	4.40	0.1732	47.0	80.0	4.40
A7774.5	–	4.50	0.1772	47.0	80.0	4.50
A7774.6	–	4.60	0.1811	47.0	80.0	4.60
A7774.7	–	4.70	0.1850	47.0	80.0	4.70
A7773/16	3/16	4.76	0.1875	52.0	86.0	4.76
A7774.8	–	4.80	0.1890	52.0	86.0	4.80
A7774.9	–	4.90	0.1929	52.0	86.0	4.90
A7775.0	–	5.00	0.1969	52.0	86.0	5.00
A7775.1	–	5.10	0.2008	52.0	86.0	5.10
A77713/64	13/64	5.16	0.2031	52.0	86.0	5.16
A7775.2	–	5.20	0.2047	52.0	86.0	5.20
A7775.3	–	5.30	0.2087	52.0	86.0	5.30
A7775.4	–	5.40	0.2126	57.0	93.0	5.40
A7775.5	–	5.50	0.2165	57.0	93.0	5.50
A7777/32	7/32	5.56	0.2188	57.0	93.0	5.56
A7775.6	–	5.60	0.2205	57.0	93.0	5.60
A7775.7	–	5.70	0.2244	57.0	93.0	5.70
A7775.8	–	5.80	0.2283	57.0	93.0	5.80
A7775.9	–	5.90	0.2323	57.0	93.0	5.90
A77715/64	15/64	5.95	0.2344	57.0	93.0	5.95
A7776.0	–	6.00	0.2362	57.0	93.0	6.00
A7776.1	–	6.10	0.2402	63.0	101.0	6.10
A7776.2	–	6.20	0.2441	63.0	101.0	6.20
A7776.3	–	6.30	0.2480	63.0	101.0	6.30
A7771/4	1/4	6.35	0.2500	63.0	101.0	6.35
A7776.4	–	6.40	0.2520	63.0	101.0	6.40
A7776.5	–	6.50	0.2559	63.0	101.0	6.50
A7776.6	–	6.60	0.2598	63.0	101.0	6.60
A7776.7	–	6.70	0.2638	63.0	101.0	6.70
A77717/64	17/64	6.75	0.2656	69.0	109.0	6.75
A7776.8	–	6.80	0.2677	69.0	109.0	6.80
A7776.9	–	6.90	0.2717	69.0	109.0	6.90
A7777.0	–	7.00	0.2756	69.0	109.0	7.00
A7777.1	–	7.10	0.2795	69.0	109.0	7.10
A7779/32	9/32	7.14	0.2813	69.0	109.0	7.14
A7777.2	–	7.20	0.2835	69.0	109.0	7.20
A7777.3	–	7.30	0.2874	69.0	109.0	7.30
A7777.4	–	7.40	0.2913	69.0	109.0	7.40
A7777.5	–	7.50	0.2953	69.0	109.0	7.50
A77719/64	19/64	7.54	0.2969	75.0	117.0	7.54
A7777.6	–	7.60	0.2992	75.0	117.0	7.60
A7777.7	–	7.70	0.3031	75.0	117.0	7.70
A7777.8	–	7.80	0.3071	75.0	117.0	7.80
A7777.9	–	7.90	0.3110	75.0	117.0	7.90
A7775/16	5/16	7.94	0.3125	75.0	117.0	7.94
A7778.0	–	8.00	0.3150	75.0	117.0	8.00

Product	DC	DC	DC	LCF	OAL	D CON MS
	(inch)	(mm)	(inch)	(mm)	(mm)	(mm)
A7778.1	–	8.10	0.3189	75.0	117.0	8.10
A7778.2	–	8.20	0.3228	75.0	117.0	8.20
A7778.3	–	8.30	0.3268	75.0	117.0	8.30
A77721/64	21/64	8.33	0.3281	75.0	117.0	8.33
A7778.4	–	8.40	0.3307	75.0	117.0	8.40
A7778.5	–	8.50	0.3346	75.0	117.0	8.50
A7778.6	–	8.60	0.3386	81.0	125.0	8.60
A7778.7	–	8.70	0.3425	81.0	125.0	8.70
A77711/32	11/32	8.73	0.3438	81.0	125.0	8.73
A7778.8	–	8.80	0.3465	81.0	125.0	8.80
A7778.9	–	8.90	0.3504	81.0	125.0	8.90
A7779.0	–	9.00	0.3543	81.0	125.0	9.00
A7779.1	–	9.10	0.3583	81.0	125.0	9.10
A77723/64	23/64	9.13	0.3594	81.0	125.0	9.13
A7779.2	–	9.20	0.3622	81.0	125.0	9.20
A7779.3	–	9.30	0.3661	81.0	125.0	9.30
A7779.4	–	9.40	0.3701	81.0	125.0	9.40
A7779.5	–	9.50	0.3740	81.0	125.0	9.50
A7773/8	3/8	9.52	0.3750	87.0	133.0	9.52
A7779.6	–	9.60	0.3780	87.0	133.0	9.60
A7779.7	–	9.70	0.3819	87.0	133.0	9.70
A7779.8	–	9.80	0.3858	87.0	133.0	9.80
A7779.9	–	9.90	0.3898	87.0	133.0	9.90
A77725/64	25/64	9.92	0.3906	87.0	133.0	9.92
A77710.0	–	10.00	0.3937	87.0	133.0	10.00
A77710.1	–	10.10	0.3976	87.0	133.0	10.10
A77710.2	–	10.20	0.4016	87.0	133.0	10.20
A77713/32	13/32	10.32	0.4063	87.0	133.0	10.32
A77710.5	–	10.50	0.4134	87.0	133.0	10.50
A77727/64	27/64	10.72	0.4219	94.0	142.0	10.72
A77710.8	–	10.80	0.4252	94.0	142.0	10.80
A77711.0	–	11.00	0.4331	94.0	142.0	11.00
A7777/16	7/16	11.11	0.4375	94.0	142.0	11.11
A77711.2	–	11.20	0.4409	94.0	142.0	11.20
A77711.5	–	11.50	0.4528	94.0	142.0	11.50
A77729/64	29/64	11.51	0.4531	94.0	142.0	11.51
A77711.8	–	11.80	0.4646	94.0	142.0	11.80
A77715/32	15/32	11.91	0.4688	101.0	151.0	11.91
A77712.0	–	12.00	0.4724	101.0	151.0	12.00
A77712.2	–	12.20	0.4803	101.0	151.0	12.20
A77731/64	31/64	12.30	0.4844	101.0	151.0	12.30
A77712.5	–	12.50	0.4921	101.0	151.0	12.50
A7771/2	1/2	12.70	0.5000	101.0	151.0	12.70
A77712.8	–	12.80	0.5039	101.0	151.0	12.80
A77713.0	–	13.00	0.5118	101.0	151.0	13.00
A77713.5	–	13.50	0.5315	108.0	160.0	13.50
A77714.0	–	14.00	0.5512	108.0	160.0	14.00
A77714.5	–	14.50	0.5709	114.0	169.0	14.50
A77715.0	–	15.00	0.5906	114.0	169.0	15.00
A77715.5	–	15.50	0.6102	120.0	178.0	15.50
A77716.0	–	16.00	0.6299	120.0	178.0	16.00

A147



Foret court en HSS-E (5% cobalt), finition brillante (conçu pour l'acier inoxydable)

Foret polyvalent et résistant qui répond à toutes les exigences de perçage sur machines dans les aciers inoxydables, mais qui peut également être utilisé pour les opérations à la main. Sa pointe à 130° avec affûtage en croix aide à l'auto-centrage et réduit les forces de coupe. Finition brillante.

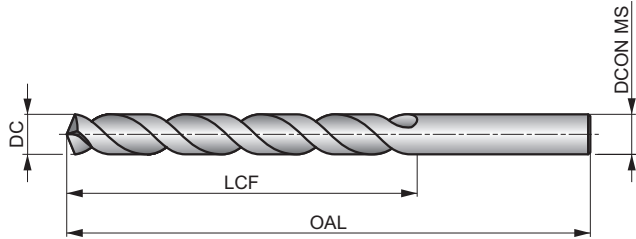

HSS-E	DIN 338	4×D
130°	Bright	
VA	R	DC h8

Adéquation du groupe de matériaux de la pièce, valeurs de départ pour la vitesse de coupe (m/min) et code Alpha d'avance. Les tableaux d'avances par tour se trouvent à partir de la page 274.

P1.1 33 I	P1.2 37 I	P1.3 38 I	P2.1 28 I	P2.2 25 G	P2.3 22 E	P3.1 19 F	P3.2 15 F	P3.3 13 E	P4.1 11 F	P4.2 10 E	P4.3 8 D	M1.1 21 E	M1.2 17 E
M2.1 18 E	M2.2 15 E	M2.3 13 B	M3.1 10 G	M3.2 9 G	M3.3 8 G	M4.1 10 D	M4.2 9 B	K1.1 30 H	K1.2 22 F	K1.3 17 F	K2.1 25 E	K2.2 20 E	K2.3 16 E
K3.1 22 E	K3.2 17 E	K3.3 13 E	K4.1 20 E	K4.2 15 E	K4.3 11 E	K4.4 10 E	K4.5 8 E	K5.1 23 E	K5.2 17 E	K5.3 13 E	N1.1 33 J	N1.2 25 J	N1.3 17 I
N2.1 42 H	N2.2 37 H	N2.3 27 H	N3.1 59 H	N3.2 35 I	N3.3 18 G	N4.1 30 J	N4.2 28 H	N4.3 14 F	S1.1 25 G	S1.2 16 E	S1.3 7 B	S2.1 9 G	S2.2 8 E
S3.1 7 G	S3.2 6 E	S4.1 5 G	S4.2 5 E										

Product	DC (inch)	DC (mm)	DC (inch)	LCF (mm)	OAL (mm)	DCON MS (mm)
A147.3	–	0.30	0.0118	3.0	19.0	0.30
A147.4	–	0.40	0.0157	5.0	20.0	0.40
A147.5	–	0.50	0.0197	6.0	22.0	0.50
A147.6	–	0.60	0.0236	7.0	24.0	0.60
A147.7	–	0.70	0.0276	9.0	28.0	0.70
A147.8	–	0.80	0.0315	10.0	30.0	0.80
A147.9	–	0.90	0.0354	11.0	32.0	0.90
A1471.0	–	1.00	0.0394	12.0	34.0	1.00
A1471.1	–	1.10	0.0433	14.0	36.0	1.10
A1471.2	–	1.20	0.0472	16.0	38.0	1.20
A1471.3	–	1.30	0.0512	16.0	38.0	1.30
A1471.4	–	1.40	0.0551	18.0	40.0	1.40
A1471.5	–	1.50	0.0591	18.0	40.0	1.50
A1471/16	1/16	1.59	0.0625	20.0	43.0	1.59
A1471.6	–	1.60	0.0630	20.0	43.0	1.60
A1471.7	–	1.70	0.0669	20.0	43.0	1.70
A1471.8	–	1.80	0.0709	22.0	46.0	1.80
A1471.9	–	1.90	0.0748	22.0	46.0	1.90
A1472.0	–	2.00	0.0787	24.0	49.0	2.00
A1472.1	–	2.10	0.0827	24.0	49.0	2.10
A1472.2	–	2.20	0.0866	27.0	53.0	2.20
A1472.3	–	2.30	0.0906	27.0	53.0	2.30
A1473/32	3/32	2.38	0.0938	30.0	57.0	2.38
A1472.4	–	2.40	0.0945	30.0	57.0	2.40

Product	DC (inch)	DC (mm)	DC (inch)	LCF (mm)	OAL (mm)	DCON MS (mm)
A1472.5	–	2.50	0.0984	30.0	57.0	2.50
A1472.6	–	2.60	0.1024	30.0	57.0	2.60
A1472.7	–	2.70	0.1063	33.0	61.0	2.70
A1472.8	–	2.80	0.1102	33.0	61.0	2.80
A1472.9	–	2.90	0.1142	33.0	61.0	2.90
A1473.0	–	3.00	0.1181	33.0	61.0	3.00
A1473.1	–	3.10	0.1220	36.0	65.0	3.10
A1471/8	1/8	3.18	0.1250	36.0	65.0	3.18
A1473.2	–	3.20	0.1260	36.0	65.0	3.20
A1473.3	–	3.30	0.1299	36.0	65.0	3.30
A1473.4	–	3.40	0.1339	39.0	70.0	3.40
A1473.5	–	3.50	0.1378	39.0	70.0	3.50
A1473.6	–	3.60	0.1417	39.0	70.0	3.60
A1473.7	–	3.70	0.1457	39.0	70.0	3.70
A1473.8	–	3.80	0.1496	43.0	75.0	3.80
A1473.9	–	3.90	0.1535	43.0	75.0	3.90
A1475/32	5/32	3.97	0.1563	43.0	75.0	3.97
A1474.0	–	4.00	0.1575	43.0	75.0	4.00
A1474.1	–	4.10	0.1614	43.0	75.0	4.10
A1474.2	–	4.20	0.1654	43.0	75.0	4.20
A1474.3	–	4.30	0.1693	47.0	80.0	4.30
A1474.4	–	4.40	0.1732	47.0	80.0	4.40
A1474.5	–	4.50	0.1772	47.0	80.0	4.50
A1474.6	–	4.60	0.1811	47.0	80.0	4.60



Product	DC	DC	DC	LCF	OAL	DCON MS
	(inch)	(mm)	(inch)	(mm)	(mm)	(mm)
A1474.7	–	4.70	0.1850	47.0	80.0	4.70
A1473/16	3/16	4.76	0.1875	52.0	86.0	4.76
A1474.8	–	4.80	0.1890	52.0	86.0	4.80
A1474.9	–	4.90	0.1929	52.0	86.0	4.90
A1475.0	–	5.00	0.1969	52.0	86.0	5.00
A1475.1	–	5.10	0.2008	52.0	86.0	5.10
A1475.2	–	5.20	0.2047	52.0	86.0	5.20
A1475.3	–	5.30	0.2087	52.0	86.0	5.30
A1475.4	–	5.40	0.2126	57.0	93.0	5.40
A1475.5	–	5.50	0.2165	57.0	93.0	5.50
A1475.6	–	5.60	0.2205	57.0	93.0	5.60
A1475.7	–	5.70	0.2244	57.0	93.0	5.70
A1475.8	–	5.80	0.2283	57.0	93.0	5.80
A1475.9	–	5.90	0.2323	57.0	93.0	5.90
A1476.0	–	6.00	0.2362	57.0	93.0	6.00
A1476.1	–	6.10	0.2402	63.0	101.0	6.10
A1476.2	–	6.20	0.2441	63.0	101.0	6.20
A1476.3	–	6.30	0.2480	63.0	101.0	6.30
A1471/4	1/4	6.35	0.2500	63.0	101.0	6.35
A1476.4	–	6.40	0.2520	63.0	101.0	6.40
A1476.5	–	6.50	0.2559	63.0	101.0	6.50
A1476.6	–	6.60	0.2598	63.0	101.0	6.60
A1476.7	–	6.70	0.2638	63.0	101.0	6.70
A1476.8	–	6.80	0.2677	69.0	109.0	6.80
A1476.9	–	6.90	0.2717	69.0	109.0	6.90
A1477.0	–	7.00	0.2756	69.0	109.0	7.00
A1477.1	–	7.10	0.2795	69.0	109.0	7.10
A1477.2	–	7.20	0.2835	69.0	109.0	7.20
A1477.3	–	7.30	0.2874	69.0	109.0	7.30
A1477.4	–	7.40	0.2913	69.0	109.0	7.40
A1477.5	–	7.50	0.2953	69.0	109.0	7.50

Product	DC	DC	DC	LCF	OAL	DCON MS
	(inch)	(mm)	(inch)	(mm)	(mm)	(mm)
A1477.7	–	7.70	0.3031	75.0	117.0	7.70
A1477.8	–	7.80	0.3071	75.0	117.0	7.80
A1477.9	–	7.90	0.3110	75.0	117.0	7.90
A1478.0	–	8.00	0.3150	75.0	117.0	8.00
A1478.1	–	8.10	0.3189	75.0	117.0	8.10
A1478.2	–	8.20	0.3228	75.0	117.0	8.20
A1478.3	–	8.30	0.3268	75.0	117.0	8.30
A1478.4	–	8.40	0.3307	75.0	117.0	8.40
A1478.5	–	8.50	0.3346	75.0	117.0	8.50
A1478.6	–	8.60	0.3386	81.0	125.0	8.60
A1478.7	–	8.70	0.3425	81.0	125.0	8.70
A1478.8	–	8.80	0.3465	81.0	125.0	8.80
A1478.9	–	8.90	0.3504	81.0	125.0	8.90
A1479.0	–	9.00	0.3543	81.0	125.0	9.00
A1479.1	–	9.10	0.3583	81.0	125.0	9.10
A1479.2	–	9.20	0.3622	81.0	125.0	9.20
A1479.5	–	9.50	0.3740	81.0	125.0	9.50
A1479.7	–	9.70	0.3819	87.0	133.0	9.70
A1479.8	–	9.80	0.3858	87.0	133.0	9.80
A14710.0	–	10.00	0.3937	87.0	133.0	10.00
A14710.2	–	10.20	0.4016	87.0	133.0	10.20
A14710.5	–	10.50	0.4134	87.0	133.0	10.50
A14711.0	–	11.00	0.4331	94.0	142.0	11.00
A14711.5	–	11.50	0.4528	94.0	142.0	11.50
A14712.0	–	12.00	0.4724	101.0	151.0	12.00
A14712.5	–	12.50	0.4921	101.0	151.0	12.50
A14713.0	–	13.00	0.5118	101.0	151.0	13.00
A14713.5	–	13.50	0.5315	108.0	160.0	13.50
A14714.0	–	14.00	0.5512	108.0	160.0	14.00
A14715.0	–	15.00	0.5906	114.0	169.0	15.00

A510



Foret court ADX en HSS, revêtement TiN

Foret haute performance capable de produire des trous de haute qualité et précis à des vitesses et des avances élevées (tolérance de trou H9). Sa pointe amincie à 130° facilite l'auto-centrage. Ce foret doit être utilisé sur des machines CNC uniquement. Le revêtement TiN améliore les performances et prolonge la durée de vie de l'outil. Convient pour le perçage de nombreux matériaux.

ADX

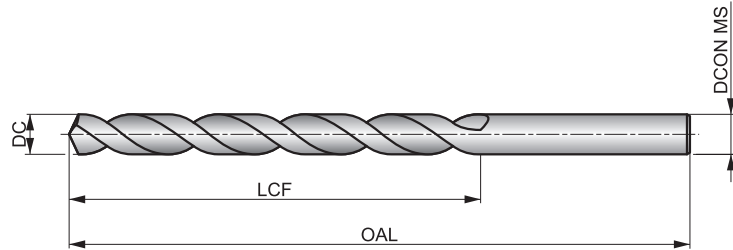

HSS	DIN 338	4×D
130°	TiN	
λ 32-40°	R	DC h8

Adéquation du groupe de matériaux de la pièce, valeurs de départ pour la vitesse de coupe (m/min) et code Alpha d'avance. Les tableaux d'avances par tour se trouvent à partir de la page 274.

P1.1 ■ 53 M	P1.2 ■ 59 M	P1.3 ■ 61 M	P2.1 ■ 45 M	P2.2 ■ 40 K	P2.3 ■ 35 F	P3.1 ■ 31 H	P3.2 ■ 25 H	P3.3 ■ 21 F	P4.1 ■ 19 H	P4.2 ■ 16 F	P4.3 ■ 13 D	M1.1 ■ 38 G	M1.2 ■ 32 G
M2.1 ■ 34 G	M2.2 ■ 28 G	M3.1 ■ 16 I	M3.2 ■ 14 I	M3.3 ■ 13 I	M4.1 ■ 19 G	K1.1 ■ 42 K	K1.2 ■ 31 J	K1.3 ■ 23 J	K2.1 ■ 34 J	K2.2 ■ 28 J	K2.3 ■ 22 F	K3.1 ■ 30 J	K3.2 ■ 23 J
K3.3 ■ 19 F	K4.1 ■ 28 J	K4.2 ■ 21 J	K4.3 ■ 16 F	K4.4 ■ 13 F	K4.5 ■ 11 F	K5.1 ■ 32 J	K5.2 ■ 24 J	K5.3 ■ 19 F	N1.1 ■ 50 G	N1.2 ■ 38 G	N1.3 ■ 25 M	N2.1 ■ 48 I	N2.2 ■ 43 I
N2.3 ■ 31 I	N3.1 ■ 85 I	N3.2 ■ 50 I	N3.3 ■ 25 D	N4.1 ■ 65 G	N4.2 ■ 50 G	N4.3 ■ 35 F	S1.1 ■ 32 G	S1.2 ■ 20 H	S1.3 ■ 4 B	S2.1 ■ 12 E	S2.2 ■ 8 E	S3.1 ■ 9 E	S3.2 ■ 6 E
S4.1 ■ 7 E	S4.2 ■ 5 E												

Product	DC (inch)	DC (mm)	DC (inch)	LCF (mm)	OAL (mm)	DCON MS (mm)
A5103.0	–	3.00	0.1181	33.0	61.0	3.00
A5103.1	–	3.10	0.1220	36.0	65.0	3.10
A5101/8	1/8	3.18	0.1250	36.0	65.0	3.18
A5103.2	–	3.20	0.1260	36.0	65.0	3.20
A5103.3	–	3.30	0.1299	36.0	65.0	3.30
A5103.4	–	3.40	0.1339	39.0	70.0	3.40
A5103.5	–	3.50	0.1378	39.0	70.0	3.50
A5109/64	9/64	3.57	0.1406	39.0	70.0	3.57
A5103.6	–	3.60	0.1417	39.0	70.0	3.60
A5103.7	–	3.70	0.1457	39.0	70.0	3.70
A5103.8	–	3.80	0.1496	43.0	75.0	3.80
A5103.9	–	3.90	0.1535	43.0	75.0	3.90
A5105/32	5/32	3.97	0.1563	43.0	75.0	3.97
A5104.0	–	4.00	0.1575	43.0	75.0	4.00
A5104.1	–	4.10	0.1614	43.0	75.0	4.10
A5104.2	–	4.20	0.1654	43.0	75.0	4.20
A5104.3	–	4.30	0.1693	47.0	80.0	4.30
A5104.4	–	4.40	0.1732	47.0	80.0	4.40
A5104.5	–	4.50	0.1772	47.0	80.0	4.50
A5104.6	–	4.60	0.1811	47.0	80.0	4.60
A5104.7	–	4.70	0.1850	47.0	80.0	4.70
A5103/16	3/16	4.76	0.1875	52.0	86.0	4.76
A5104.8	–	4.80	0.1890	52.0	86.0	4.80
A5104.9	–	4.90	0.1929	52.0	86.0	4.90

Product	DC (inch)	DC (mm)	DC (inch)	LCF (mm)	OAL (mm)	DCON MS (mm)
A5105.0	–	5.00	0.1969	52.0	86.0	5.00
A5105.1	–	5.10	0.2008	52.0	86.0	5.10
A51013/64	13/64	5.16	0.2031	52.0	86.0	5.16
A5105.2	–	5.20	0.2047	52.0	86.0	5.20
A5105.3	–	5.30	0.2087	52.0	86.0	5.30
A5105.4	–	5.40	0.2126	57.0	93.0	5.40
A5105.5	–	5.50	0.2165	57.0	93.0	5.50
A5107/32	7/32	5.56	0.2188	57.0	93.0	5.56
A5105.6	–	5.60	0.2205	57.0	93.0	5.60
A5105.7	–	5.70	0.2244	57.0	93.0	5.70
A5105.8	–	5.80	0.2283	57.0	93.0	5.80
A5105.9	–	5.90	0.2323	57.0	93.0	5.90
A51015/64	15/64	5.95	0.2344	57.0	93.0	5.95
A5106.0	–	6.00	0.2362	57.0	93.0	6.00
A5106.1	–	6.10	0.2402	63.0	101.0	6.10
A5106.2	–	6.20	0.2441	63.0	101.0	6.20
A5106.3	–	6.30	0.2480	63.0	101.0	6.30
A5101/4	1/4	6.35	0.2500	63.0	101.0	6.35
A5106.4	–	6.40	0.2520	63.0	101.0	6.40
A5106.5	–	6.50	0.2559	63.0	101.0	6.50
A5106.6	–	6.60	0.2598	63.0	101.0	6.60
A5106.7	–	6.70	0.2638	63.0	101.0	6.70
A51017/64	17/64	6.75	0.2656	69.0	109.0	6.75
A5106.8	–	6.80	0.2677	69.0	109.0	6.80



Product	DC	DC	DC	LCF	OAL	DCON MS
	(inch)	(mm)	(inch)	(mm)	(mm)	(mm)
A5106.9	–	6.90	0.2717	69.0	109.0	6.90
A5107.0	–	7.00	0.2756	69.0	109.0	7.00
A5107.1	–	7.10	0.2795	69.0	109.0	7.10
A5109/32	9/32	7.14	0.2813	69.0	109.0	7.14
A5107.2	–	7.20	0.2835	69.0	109.0	7.20
A5107.3	–	7.30	0.2874	69.0	109.0	7.30
A5107.4	–	7.40	0.2913	69.0	109.0	7.40
A5107.5	–	7.50	0.2953	69.0	109.0	7.50
A51019/64	19/64	7.54	0.2969	75.0	117.0	7.54
A5107.6	–	7.60	0.2992	75.0	117.0	7.60
A5107.8	–	7.80	0.3071	75.0	117.0	7.80
A5105/16	5/16	7.94	0.3125	75.0	117.0	7.94
A5108.0	–	8.00	0.3150	75.0	117.0	8.00
A5108.1	–	8.10	0.3189	75.0	117.0	8.10
A5108.2	–	8.20	0.3228	75.0	117.0	8.20
A5108.3	–	8.30	0.3268	75.0	117.0	8.30
A5108.5	–	8.50	0.3346	75.0	117.0	8.50
A5108.6	–	8.60	0.3386	81.0	125.0	8.60
A5108.7	–	8.70	0.3425	81.0	125.0	8.70
A51011/32	11/32	8.73	0.3438	81.0	125.0	8.73
A5108.8	–	8.80	0.3465	81.0	125.0	8.80
A5108.9	–	8.90	0.3504	81.0	125.0	8.90
A5109.0	–	9.00	0.3543	81.0	125.0	9.00
A5109.1	–	9.10	0.3583	81.0	125.0	9.10
A5109.2	–	9.20	0.3622	81.0	125.0	9.20
A5109.3	–	9.30	0.3661	81.0	125.0	9.30
A5109.4	–	9.40	0.3701	81.0	125.0	9.40
A5109.5	–	9.50	0.3740	81.0	125.0	9.50
A5103/8	3/8	9.52	0.3750	87.0	133.0	9.52

Product	DC	DC	DC	LCF	OAL	DCON MS
	(inch)	(mm)	(inch)	(mm)	(mm)	(mm)
A5109.6	–	9.60	0.3780	87.0	133.0	9.60
A5109.7	–	9.70	0.3819	87.0	133.0	9.70
A5109.8	–	9.80	0.3858	87.0	133.0	9.80
A5109.9	–	9.90	0.3898	87.0	133.0	9.90
A51025/64	25/64	9.92	0.3906	87.0	133.0	9.92
A51010.0	–	10.00	0.3937	87.0	133.0	10.00
A51010.1	–	10.10	0.3976	87.0	133.0	10.10
A51010.2	–	10.20	0.4016	87.0	133.0	10.20
A51010.3	–	10.30	0.4055	87.0	133.0	10.30
A51013/32	13/32	10.32	0.4063	87.0	133.0	10.32
A51010.4	–	10.40	0.4094	87.0	133.0	10.40
A51010.5	–	10.50	0.4134	87.0	133.0	10.50
A51027/64	27/64	10.72	0.4219	94.0	142.0	10.72
A51010.8	–	10.80	0.4252	94.0	142.0	10.80
A51011.0	–	11.00	0.4331	94.0	142.0	11.00
A51011.1	–	11.10	0.4370	94.0	142.0	11.10
A5107/16	7/16	11.11	0.4375	94.0	142.0	11.11
A51011.5	–	11.50	0.4528	94.0	142.0	11.50
A51011.7	–	11.70	0.4606	94.0	142.0	11.70
A51011.8	–	11.80	0.4646	94.0	142.0	11.80
A51015/32	15/32	11.91	0.4688	101.0	151.0	11.91
A51012.0	–	12.00	0.4724	101.0	151.0	12.00
A51012.3	–	12.30	0.4843	101.0	151.0	12.30
A51031/64	31/64	12.30	0.4844	101.0	151.0	12.30
A51012.5	–	12.50	0.4921	101.0	151.0	12.50
A5101/2	1/2	12.70	0.5000	101.0	151.0	12.70
A51013.0	–	13.00	0.5118	101.0	151.0	13.00
A51014.0	–	14.00	0.5512	108.0	160.0	14.00

A553



Foret court ADX en HSS-E (5% Cobalt), revêtement TiAlN avec arrosage centralisé

Foret haute performance capable de produire des trous de haute qualité et précis à des vitesses et des avances élevées (tolérance de trou H9). Sa pointe amincie à 130° et le revêtement TiAlN Top améliorent les performances et prolongent la durée de vie de l'outil. Ce foret ne doit être utilisé que sur des machines CNC. Convient pour le perçage de nombreux matériaux.

ADX

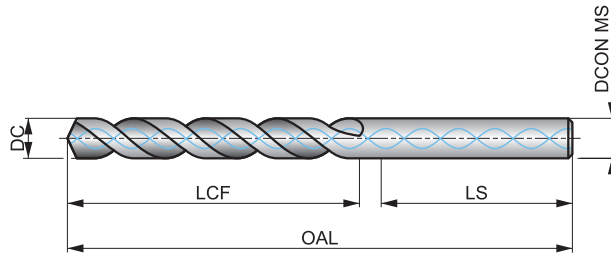

HSS-E	DORMER	5xD
130°	TiAlN Top	DIN 6535HA
λ>35°	R	
DC h8		

Adéquation du groupe de matériaux de la pièce, valeurs de départ pour la vitesse de coupe (m/min) et code Alpha d'avance. Les tableaux d'avances par tour se trouvent à partir de la page 274.

P1.1 ■ 80 L	P1.2 ■ 89 L	P1.3 ■ 92 L	P2.1 ■ 68 L	P2.2 ■ 60 L	P2.3 ■ 53 F	P3.1 ■ 41 H	P3.2 ■ 33 H	P3.3 ■ 28 F	P4.1 ■ 25 H	P4.2 ■ 21 F	P4.3 ■ 17 D	M1.1 ■ 55 G	M1.2 ■ 46 G
M2.1 ■ 49 G	M2.2 ■ 40 G	M3.1 ■ 22 I	M3.2 ■ 19 I	M3.3 ▣ 17 I	M4.1 ▣ 27 G	K1.1 ■ 70 K	K1.2 ■ 52 J	K1.3 ■ 39 J	K2.1 ■ 55 J	K2.2 ■ 45 J	K2.3 ■ 36 F	K3.1 ■ 49 J	K3.2 ■ 37 J
K3.3 ■ 30 F	K4.1 ■ 45 J	K4.2 ■ 34 J	K4.3 ■ 25 F	K4.4 ■ 22 F	K4.5 ■ 18 F	K5.1 ■ 51 J	K5.2 ■ 39 J	K5.3 ■ 30 F	N1.1 ▣ 70 H	N1.2 ▣ 53 H	N1.3 ■ 35 M	N2.1 ■ 85 I	N2.2 ■ 76 I
N2.3 ■ 55 I	N3.1 ■ 144 I	N3.2 ■ 85 I	N3.3 ▣ 43 G	N4.1 ■ 90 G	S1.1 ■ 45 G	S1.2 ▣ 30 E	S1.3 ▣ 8 C	S2.1 ▣ 20 E	S2.2 ▣ 14 G	S3.1 ▣ 15 E	S3.2 ▣ 10 G	S4.1 ▣ 12 E	S4.2 ▣ 8 G

DCON MS tolérance h6.

Product	DC (mm)	DC (inch)	LCF (mm)	OAL (mm)	LS (mm)	DCON MS (mm)
A5535.0	5.00	0.1969	36.0	79.0	36.0	6.00
A5535.5	5.50	0.2165	40.0	79.0	36.0	6.00
A5536.0	6.00	0.2362	43.0	79.0	36.0	6.00
A5538.0	8.00	0.3150	58.0	94.0	36.0	8.00
A5538.5	8.50	0.3346	75.0	130.0	40.0	10.00
A5539.0	9.00	0.3543	75.0	130.0	40.0	10.00
A5539.5	9.50	0.3740	75.0	130.0	40.0	10.00
A55310.3	10.30	0.4055	87.0	150.0	45.0	12.00
A55311.0	11.00	0.4331	94.0	150.0	45.0	12.00

Product	DC (mm)	DC (inch)	LCF (mm)	OAL (mm)	LS (mm)	DCON MS (mm)
A55311.3	11.30	0.4449	94.0	150.0	45.0	12.00
A55311.5	11.50	0.4528	94.0	150.0	45.0	12.00
A55312.0	12.00	0.4724	94.0	150.0	45.0	12.00
A55312.5	12.50	0.4921	101.0	160.0	45.0	14.00
A55313.0	13.00	0.5118	101.0	160.0	45.0	14.00
A55313.5	13.50	0.5315	101.0	160.0	45.0	14.00
A55314.0	14.00	0.5512	101.0	160.0	45.0	14.00
A55315.0	15.00	0.5906	108.0	170.0	48.0	16.00
A55318.0	18.00	0.7087	130.0	190.0	48.0	18.00

R003



Foret court en carbure monobloc, avec pointe revêtue TiN

Foret polyvalent d'entrée de gamme avec un angle de pointe de 120°. La géométrie de pointe à quatre facettes réduit la force de poussée et la construction de goujures CTW améliore les taux de pénétration. Le revêtement TiN de la pointe améliore les performances et prolonge la durée de vie de l'outil. Convient aux machines à commande numérique et conventionnelles pour une large gamme de matériaux de pièces à usiner.

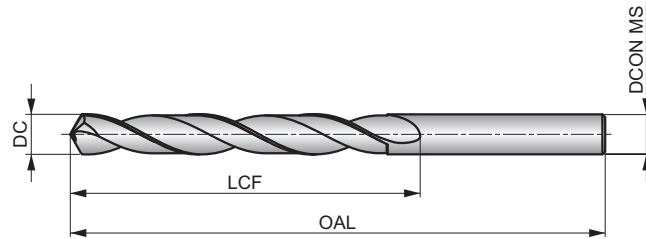

HM	DIN 338	4xD
120°	TiN-Tip	
λ 20-35°	R	DC h7

Adéquation du groupe de matériaux de la pièce, valeurs de départ pour la vitesse de coupe (m/min) et code Alpha d'avance. Les tableaux d'avances par tour se trouvent à partir de la page 274.

P1.1 ■ 99 S	P1.2 ■ 111 S	P1.3 ■ 115 S	P2.1 ■ 85 S	P2.2 ■ 75 S	P2.3 ■ 66 S	P3.1 ■ 66 S	P3.2 ■ 53 S	P3.3 ■ 45 S	P4.1 ■ 40 S	P4.2 ■ 34 S	P4.3 ■ 27 S	K1.1 ■ 75 T	K1.2 ■ 56 T
K1.3 ■ 42 T	K2.1 ■ 68 T	K2.2 ■ 55 T	K2.3 ■ 44 T	K3.1 ■ 60 T	K3.2 ■ 46 T	K3.3 ■ 37 T	K4.1 ■ 55 T	K4.2 ■ 42 T	K4.3 ■ 31 T	K4.4 ■ 26 T	K4.5 ■ 22 T	K5.1 ■ 63 T	K5.2 ■ 47 T
K5.3 ■ 37 T	N1.1 ■ 150 V	N1.2 ■ 113 V	N1.3 ■ 75 V	N2.1 ■ 129 V	N2.2 ■ 116 V	N2.3 ■ 84 V	N3.1 ■ 317 V	N3.2 ■ 190 V	N4.1 ■ 60 U	N4.2 ■ 100 U	H1.1 ■ 34 S	H2.1 ■ 20 S	H3.1 ■ 22 S

Product	DC (inch)	DC (mm)	DC (inch)	LCF (mm)	OAL (mm)	DCON MS (mm)
R0031.0	–	1.00	0.0394	12.0	34.0	1.00
R003N60	N60	1.02	0.0400	12.0	34.0	1.02
R0031.1	–	1.10	0.0433	14.0	36.0	1.10
R003N56	N56	1.18	0.0465	16.0	38.0	1.18
R0033/64	3/64	1.19	0.0469	16.0	38.0	1.19
R0031.2	–	1.20	0.0472	16.0	38.0	1.20
R0031.3	–	1.30	0.0512	16.0	38.0	1.30
R003N54	N54	1.40	0.0550	18.0	40.0	1.40
R0031.4	–	1.40	0.0551	18.0	40.0	1.40
R0031.5	–	1.50	0.0591	18.0	40.0	1.50
R003N53	N53	1.51	0.0595	20.0	43.0	1.51
R0031/16	1/16	1.59	0.0625	20.0	43.0	1.59
R0031.6	–	1.60	0.0630	20.0	43.0	1.60
R003N52	N52	1.61	0.0635	20.0	43.0	1.61
R0031.7	–	1.70	0.0669	20.0	43.0	1.70
R003N51	N51	1.70	0.0670	22.0	46.0	1.70
R003N50	N50	1.78	0.0700	22.0	46.0	1.78
R0031.8	–	1.80	0.0709	22.0	46.0	1.80
R0031.9	–	1.90	0.0748	22.0	46.0	1.90
R003N48	N48	1.93	0.0760	24.0	49.0	1.93
R0035/64	5/64	1.98	0.0781	24.0	49.0	1.98
R003N47	N47	1.99	0.0785	24.0	49.0	1.99
R0032.0	–	2.00	0.0787	24.0	49.0	2.00
R003N46	N46	2.06	0.0810	24.0	49.0	2.06
R0032.1	–	2.10	0.0827	24.0	49.0	2.10
R003N44	N44	2.18	0.0860	27.0	53.0	2.18
R0032.2	–	2.20	0.0866	27.0	53.0	2.20
R003N43	N43	2.26	0.0890	27.0	53.0	2.26

Product	DC (inch)	DC (mm)	DC (inch)	LCF (mm)	OAL (mm)	DCON MS (mm)
R0032.3	–	2.30	0.0906	27.0	53.0	2.30
R0033/32	3/32	2.38	0.0937	30.0	57.0	2.38
R0032.4	–	2.40	0.0945	30.0	57.0	2.40
R003N41	N41	2.44	0.0960	30.0	57.0	2.44
R0032.5	–	2.50	0.0984	30.0	57.0	2.50
R003N39	N39	2.53	0.0995	30.0	57.0	2.53
R003N38	N38	2.58	0.1015	30.0	57.0	2.58
R0032.6	–	2.60	0.1024	30.0	57.0	2.60
R003N37	N37	2.64	0.1040	30.0	57.0	2.64
R0032.7	–	2.70	0.1063	33.0	61.0	2.70
R003N36	N36	2.71	0.1065	33.0	61.0	2.71
R0037/64	7/64	2.78	0.1094	33.0	61.0	2.78
R0032.8	–	2.80	0.1102	33.0	61.0	2.80
R003N33	N33	2.87	0.1130	33.0	61.0	2.87
R0032.9	–	2.90	0.1142	33.0	61.0	2.90
R003N32	N32	2.95	0.1160	33.0	61.0	2.95
R0033.0	–	3.00	0.1181	33.0	61.0	3.00
R003N31	N31	3.05	0.1200	36.0	65.0	3.05
R0033.1	–	3.10	0.1220	36.0	65.0	3.10
R0031/8	1/8	3.17	0.1250	36.0	65.0	3.17
R0033.2	–	3.20	0.1260	36.0	65.0	3.20
R0033.3	–	3.30	0.1299	36.0	65.0	3.30
R0033.4	–	3.40	0.1339	39.0	70.0	3.40
R003N29	N29	3.45	0.1360	39.0	70.0	3.45
R0033.5	–	3.50	0.1378	39.0	70.0	3.50
R003N28	N28	3.57	0.1405	39.0	70.0	3.57
R0039/64	9/64	3.57	0.1406	39.0	70.0	3.57
R0033.6	–	3.60	0.1417	39.0	70.0	3.60

Product	DC	DC	DC	LCF	OAL	D CON MS
	(inch)	(mm)	(inch)	(mm)	(mm)	(mm)
R0033.7	–	3.70	0.1457	39.0	70.0	3.70
R003N26	N26	3.73	0.1470	39.0	70.0	3.73
R003N25	N25	3.80	0.1495	43.0	75.0	3.80
R0033.8	–	3.80	0.1496	43.0	75.0	3.80
R0033.9	–	3.90	0.1535	43.0	75.0	3.90
R0035/32	5/32	3.97	0.1563	43.0	75.0	3.97
R0034.0	–	4.00	0.1575	43.0	75.0	4.00
R003N21	N21	4.04	0.1590	43.0	75.0	4.04
R003N20	N20	4.09	0.1610	43.0	75.0	4.09
R0034.1	–	4.10	0.1614	43.0	75.0	4.10
R0034.2	–	4.20	0.1654	43.0	75.0	4.20
R003N19	N19	4.22	0.1660	43.0	75.0	4.22
R0034.3	–	4.30	0.1693	47.0	80.0	4.30
R00311/64	11/64	4.37	0.1719	47.0	80.0	4.37
R003N17	N17	4.39	0.1730	47.0	80.0	4.39
R0034.4	–	4.40	0.1732	47.0	80.0	4.40
R0034.5	–	4.50	0.1772	47.0	80.0	4.50
R003N15	N15	4.57	0.1800	47.0	80.0	4.57
R0034.6	–	4.60	0.1811	47.0	80.0	4.60
R0034.7	–	4.70	0.1850	47.0	80.0	4.70
R0033/16	3/16	4.76	0.1875	52.0	86.0	4.76
R003N12	N12	4.80	0.1890	52.0	86.0	4.80
R0034.8	–	4.80	0.1890	52.0	86.0	4.80
R003N11	N11	4.85	0.1910	52.0	86.0	4.85
R0034.9	–	4.90	0.1929	52.0	86.0	4.90
R003N10	N10	4.92	0.1935	52.0	86.0	4.92
R0035.0	–	5.00	0.1969	52.0	86.0	5.00
R0035.1	–	5.10	0.2008	52.0	86.0	5.10
R003N7	N7	5.11	0.2010	52.0	86.0	5.11
R00313/64	13/64	5.16	0.2031	52.0	86.0	5.16
R0035.2	–	5.20	0.2047	52.0	86.0	5.20
R0035.3	–	5.30	0.2087	52.0	86.0	5.30
R0035.4	–	5.40	0.2126	57.0	93.0	5.40
R003N3	N3	5.41	0.2130	57.0	93.0	5.41
R0035.5	–	5.50	0.2165	57.0	93.0	5.50
R0037/32	7/32	5.56	0.2187	57.0	93.0	5.56
R0035.6	–	5.60	0.2205	57.0	93.0	5.60
R003N2	N2	5.61	0.2210	57.0	93.0	5.61
R0035.7	–	5.70	0.2244	57.0	93.0	5.70
R0035.8	–	5.80	0.2283	57.0	93.0	5.80
R0035.9	–	5.90	0.2323	57.0	93.0	5.90
R00315/64	15/64	5.95	0.2344	57.0	93.0	5.95
R0036.0	–	6.00	0.2362	57.0	93.0	6.00
R0036.1	–	6.10	0.2402	63.0	101.0	6.10
R003C	C	6.15	0.2420	63.0	101.0	6.15
R0036.2	–	6.20	0.2441	63.0	101.0	6.20
R0036.3	–	6.30	0.2480	63.0	101.0	6.30
R0031/4	1/4	6.35	0.2500	63.0	101.0	6.35
R0036.4	–	6.40	0.2520	63.0	101.0	6.40
R0036.5	–	6.50	0.2559	63.0	101.0	6.50
R003F	F	6.53	0.2570	63.0	101.0	6.53
R0036.6	–	6.60	0.2598	63.0	101.0	6.60
R0036.7	–	6.70	0.2638	63.0	101.0	6.70
R00317/64	17/64	6.75	0.2656	69.0	109.0	6.75
R0036.8	–	6.80	0.2677	69.0	109.0	6.80
R0036.9	–	6.90	0.2717	69.0	109.0	6.90

Product	DC	DC	DC	LCF	OAL	D CON MS
	(inch)	(mm)	(inch)	(mm)	(mm)	(mm)
R003I	I	6.91	0.2720	69.0	109.0	6.91
R0037.0	–	7.00	0.2756	69.0	109.0	7.00
R0037.1	–	7.10	0.2795	69.0	109.0	7.10
R0039/32	9/32	7.14	0.2813	69.0	109.0	7.14
R0037.2	–	7.20	0.2835	69.0	109.0	7.20
R0037.3	–	7.30	0.2874	69.0	109.0	7.30
R0037.4	–	7.40	0.2913	69.0	109.0	7.40
R0037.5	–	7.50	0.2953	69.0	109.0	7.50
R00319/64	19/64	7.54	0.2969	75.0	117.0	7.54
R0037.6	–	7.60	0.2992	75.0	117.0	7.60
R0037.7	–	7.70	0.3031	75.0	117.0	7.70
R0037.8	–	7.80	0.3071	75.0	117.0	7.80
R0037.9	–	7.90	0.3110	75.0	117.0	7.90
R0035/16	5/16	7.94	0.3125	75.0	117.0	7.94
R0038.0	–	8.00	0.3150	75.0	117.0	8.00
R0038.1	–	8.10	0.3189	75.0	117.0	8.10
R0038.2	–	8.20	0.3228	75.0	117.0	8.20
R0038.3	–	8.30	0.3268	75.0	117.0	8.30
R00321/64	21/64	8.33	0.3281	75.0	117.0	8.33
R0038.4	–	8.40	0.3307	75.0	117.0	8.40
R003Q	Q	8.43	0.3320	75.0	117.0	8.43
R0038.5	–	8.50	0.3346	75.0	117.0	8.50
R0038.6	–	8.60	0.3386	81.0	125.0	8.60
R003R	R	8.61	0.3390	81.0	125.0	8.61
R0038.7	–	8.70	0.3425	81.0	125.0	8.70
R00311/32	11/32	8.73	0.3437	81.0	125.0	8.73
R0038.8	–	8.80	0.3465	81.0	125.0	8.80
R0038.9	–	8.90	0.3504	81.0	125.0	8.90
R0039.0	–	9.00	0.3543	81.0	125.0	9.00
R0039.1	–	9.10	0.3583	81.0	125.0	9.10
R00323/64	23/64	9.13	0.3594	81.0	125.0	9.13
R0039.2	–	9.20	0.3622	81.0	125.0	9.20
R0039.3	–	9.30	0.3661	81.0	125.0	9.30
R003U	U	9.35	0.3680	81.0	125.0	9.35
R0039.4	–	9.40	0.3701	81.0	125.0	9.40
R0039.5	–	9.50	0.3740	81.0	125.0	9.50
R0033/8	3/8	9.53	0.3750	87.0	133.0	9.53
R0039.6	–	9.60	0.3780	87.0	133.0	9.60
R0039.7	–	9.70	0.3819	87.0	133.0	9.70
R0039.8	–	9.80	0.3858	87.0	133.0	9.80
R003W	W	9.80	0.3860	87.0	133.0	9.80
R0039.9	–	9.90	0.3898	87.0	133.0	9.90
R00310.0	–	10.00	0.3937	87.0	133.0	10.00
R00310.2	–	10.20	0.4016	87.0	133.0	10.20
R00313/32	13/32	10.32	0.4063	87.0	133.0	10.32
R00310.5	–	10.50	0.4134	87.0	133.0	10.50
R00327/64	27/64	10.72	0.4219	94.0	142.0	10.72
R00311.0	–	11.00	0.4331	94.0	142.0	11.00
R0037/16	7/16	11.11	0.4375	94.0	142.0	11.11
R00311.5	–	11.50	0.4528	94.0	142.0	11.50
R00329/64	29/64	11.51	0.4531	94.0	142.0	11.51
R00315/32	15/32	11.91	0.4687	101.0	151.0	11.91
R00312.0	–	12.00	0.4724	101.0	151.0	12.00
R0031/2	1/2	12.70	0.5000	101.0	151.0	12.70
R00313.0	–	13.00	0.5118	101.0	151.0	13.00
R00314.0	–	14.00	0.5512	108.0	160.0	14.00

Code de matériau du corps (BMC)		HSS-E	HSS-E	HSS-E	HSS-E	HSS-E	HSS												
Groupe standard de base (BSG)		DIN ANSI	DIN ANSI	DIN 1869-1	DIN 1869-2	DIN 1869-3	DIN 1870(2)												
Rapport longueur utile diamètre (ULDR)		6×D	10×D	15×D	20×D	25×D	20×D												
Angle d'application																			
Revêtement		Bright	Bright	Bright	Bright	Bright	Bright ST												
Queue																			
Forme de spirale																			
Sens (direction de coupe)																			
		PFX	PFX	PFX	PFX	PFX	PFX												
Code de famille de produits		A900	A940	A976	A977	A978	A952												
Plage de diamètres de coupe PSF		1.00 - 20.00	1.00 - 19.00	1.50 - 14.00	1.50 - 14.00	3.00 - 10.00	8.00 - 30.00												
P	P1	■	■	■	■	■	■												
	P2	■	■	■	■	■	■												
	P3	■	■	■	■	■	■												
	P4	■	■	■	■	■	■												
M	M1	■	■	■	■	■	■												
	M2	■	■	■	■	■	■												
	M3	■	■	■	■	■	■												
	M4	■	■	■	■	■	■												
K	K1	■					■												
	K2	■	■	■	■	■	■												
	K3	■	■	■	■	■	■												
	K4	■	■	■	■	■	■												
	K5	■	■	■	■	■	■												
N	N1	■	■				■												
	N2	■	■				■												
	N3	■	■	■	■	■	■												
	N4	■	■				■												
	N5																		
S	S1	■	■	■	■	■	■												
	S2	■					■												
	S3	■					■												
	S4	■					■												
H	H1																		
	H2																		
	H3																		
	H4																		

A900



Foret court PFX en HSS-E (5% cobalt), finition brillante

Foret haute performance capable de produire des trous de haute qualité et précis à des vitesses et des avances élevées (tolérance de trou H10). Sa pointe auto-centrante à 130° et la conception spéciale de sa goujure parabolique permettent de percer des trous profonds en une seule passe. Convient à de nombreux matériaux.

PFX

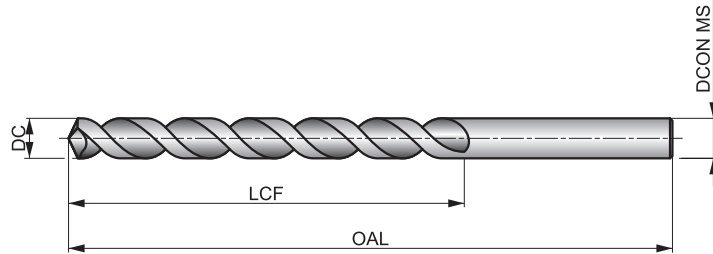

HSS-E	DIN ANSI	6×D
130°	Bright	
λ>35°		DC h8

Adéquation du groupe de matériaux de la pièce, valeurs de départ pour la vitesse de coupe (m/min) et code Alpha d'avance. Les tableaux d'avances par tour se trouvent à partir de la page 274.

P1.1 ■ 34 H	P1.2 ■ 39 H	P1.3 ■ 40 H	P2.1 ■ 30 H	P2.2 ■ 26 H	P2.3 ■ 23 E	P3.1 ■ 31 H	P3.2 ■ 25 H	P3.3 ■ 21 E	P4.1 ■ 19 H	P4.2 ■ 16 E	P4.3 ■ 13 E	M1.1 ■ 21 E	M1.2 ■ 17 E
M2.1 ■ 18 E	M2.2 ■ 15 E	M3.1 ■ 8 E	M3.2 ■ 7 E	M3.3 ■ 6 E	M4.1 ■ 9 C	K1.1 □ 24 J	K1.2 □ 18 J	K1.3 □ 13 J	K2.1 □ 23 J	K2.2 □ 19 J	K2.3 □ 15 I	K3.1 □ 21 J	K3.2 □ 16 J
K3.3 □ 13 I	K4.1 □ 19 J	K4.2 □ 14 J	K4.3 □ 11 I	K4.4 □ 9 I	K4.5 □ 8 I	K5.1 □ 22 J	K5.2 □ 16 J	K5.3 □ 13 I	N1.1 □ 60 J	N1.2 □ 45 J	N1.3 □ 30 N	N2.1 □ 62 N	N2.2 □ 55 N
N2.3 □ 40 N	N3.1 □ 90 H	N3.2 □ 53 I	N3.3 □ 27 G	N4.1 □ 55 I	N4.2 □ 40 G	S1.1 ■ 22 E	S1.2 ■ 15 E	S1.3 ■ 6 C	S2.1 ■ 9 G	S2.2 ■ 8 C	S3.1 ■ 7 G	S3.2 ■ 6 C	S4.1 ■ 5 G
S4.2 ■ 5 C													

Product	DC (inch)	DC (mm)	DC (inch)	LCF (mm)	OAL (mm)	DCON MS (mm)
A9001.0	–	1.00	0.0394	12.0	34.0	1.00
A9001.1	–	1.10	0.0433	14.0	36.0	1.10
A9001.2	–	1.20	0.0472	16.0	38.0	1.20
A9001.25	–	1.25	0.0492	16.0	36.0	1.25
A9001.3	–	1.30	0.0512	16.0	38.0	1.30
A9001.4	–	1.40	0.0551	18.0	40.0	1.40
A9001.5	–	1.50	0.0591	18.0	40.0	1.50
A9001.55	–	1.55	0.0610	20.0	43.0	1.55
A9001/16	1/16	1.59	0.0625	22.0	48.0	1.59
A9001.6	–	1.60	0.0630	20.0	43.0	1.60
A9001.7	–	1.70	0.0669	20.0	43.0	1.70
A9001.75	–	1.75	0.0689	22.0	46.0	1.75
A9001.8	–	1.80	0.0709	22.0	46.0	1.80
A9001.9	–	1.90	0.0748	22.0	46.0	1.90
A9005/64	5/64	1.98	0.0781	25.0	51.0	1.98
A9002.0	–	2.00	0.0787	24.0	49.0	2.00
A9002.1	–	2.10	0.0827	24.0	49.0	2.10
A9002.2	–	2.20	0.0866	27.0	53.0	2.20
A9002.3	–	2.30	0.0906	27.0	53.0	2.30
A9003/32	3/32	2.38	0.0937	32.0	57.0	2.38
A9002.4	–	2.40	0.0945	30.0	57.0	2.40
A9002.5	–	2.50	0.0984	30.0	57.0	2.50
A9002.6	–	2.60	0.1024	30.0	57.0	2.60
A9002.7	–	2.70	0.1063	33.0	61.0	2.70

Product	DC (inch)	DC (mm)	DC (inch)	LCF (mm)	OAL (mm)	DCON MS (mm)
A9007/64	7/64	2.78	0.1094	38.0	67.0	2.78
A9002.8	–	2.80	0.1102	33.0	61.0	2.80
A9002.9	–	2.90	0.1142	33.0	61.0	2.90
A9003.0	–	3.00	0.1181	33.0	61.0	3.00
A9003.1	–	3.10	0.1220	36.0	65.0	3.10
A9001/8	1/8	3.18	0.1250	41.0	70.0	3.18
A9003.2	–	3.20	0.1260	36.0	65.0	3.20
A9003.3	–	3.30	0.1299	36.0	65.0	3.30
A9003.4	–	3.40	0.1339	39.0	70.0	3.40
A9003.5	–	3.50	0.1378	39.0	70.0	3.50
A9009/64	9/64	3.57	0.1406	44.0	73.0	3.57
A9003.6	–	3.60	0.1417	39.0	70.0	3.60
A9003.7	–	3.70	0.1457	39.0	70.0	3.70
A9003.8	–	3.80	0.1496	43.0	75.0	3.80
A9003.9	–	3.90	0.1535	43.0	75.0	3.90
A9005/32	5/32	3.97	0.1563	51.0	79.0	3.97
A9004.0	–	4.00	0.1575	43.0	75.0	4.00
A9004.1	–	4.10	0.1614	43.0	75.0	4.10
A9004.2	–	4.20	0.1654	43.0	75.0	4.20
A9004.3	–	4.30	0.1693	47.0	80.0	4.30
A90011/64	11/64	4.37	0.1719	54.0	83.0	4.37
A9004.5	–	4.50	0.1772	47.0	80.0	4.50
A9004.6	–	4.60	0.1811	47.0	80.0	4.60
A9004.7	–	4.70	0.1850	47.0	80.0	4.70



Product	DC	DC	DC	LCF	OAL	DCON MS
	(inch)	(mm)	(inch)	(mm)	(mm)	(mm)
A9003/16	3/16	4.76	0.1875	59.0	89.0	4.76
A9004.9	–	4.90	0.1929	52.0	86.0	4.90
A9005.0	–	5.00	0.1969	52.0	86.0	5.00
A9005.1	–	5.10	0.2008	52.0	86.0	5.10
A90013/64	13/64	5.16	0.2031	62.0	92.0	5.16
A9005.2	–	5.20	0.2047	52.0	86.0	5.20
A9005.3	–	5.30	0.2087	52.0	86.0	5.30
A9005.4	–	5.40	0.2126	57.0	93.0	5.40
A9005.5	–	5.50	0.2165	57.0	93.0	5.50
A9007/32	7/32	5.56	0.2188	64.0	95.0	5.56
A9005.6	–	5.60	0.2205	57.0	93.0	5.60
A9005.7	–	5.70	0.2244	57.0	93.0	5.70
A9005.8	–	5.80	0.2283	57.0	93.0	5.80
A9005.9	–	5.90	0.2323	57.0	93.0	5.90
A9006.0	–	6.00	0.2362	57.0	93.0	6.00
A9006.1	–	6.10	0.2402	63.0	101.0	6.10
A9006.2	–	6.20	0.2441	63.0	101.0	6.20
A9006.3	–	6.30	0.2480	63.0	101.0	6.30
A9001/4	1/4	6.35	0.2500	70.0	102.0	6.35
A9006.4	–	6.40	0.2520	63.0	101.0	6.40
A9006.5	–	6.50	0.2559	63.0	101.0	6.50
A9006.6	–	6.60	0.2598	63.0	101.0	6.60
A9006.7	–	6.70	0.2638	63.0	101.0	6.70
A90017/64	17/64	6.75	0.2656	73.0	105.0	6.75
A9006.8	–	6.80	0.2677	69.0	109.0	6.80
A9006.9	–	6.90	0.2717	69.0	109.0	6.90
A9007.0	–	7.00	0.2756	69.0	109.0	7.00
A9007.1	–	7.10	0.2795	69.0	109.0	7.10
A9007.2	–	7.20	0.2835	69.0	109.0	7.20
A9007.4	–	7.40	0.2913	69.0	109.0	7.40
A9007.5	–	7.50	0.2953	69.0	109.0	7.50
A9005/16	5/16	7.94	0.3125	81.0	114.0	7.94
A9008.0	–	8.00	0.3150	75.0	117.0	8.00
A9008.1	–	8.10	0.3189	75.0	117.0	8.10
A9008.5	–	8.50	0.3346	75.0	117.0	8.50

Product	DC	DC	DC	LCF	OAL	DCON MS
	(inch)	(mm)	(inch)	(mm)	(mm)	(mm)
A9008.7	–	8.70	0.3425	81.0	125.0	8.70
A90011/32	11/32	8.73	0.3438	87.0	121.0	8.73
A9008.8	–	8.80	0.3465	81.0	125.0	8.80
A9009.0	–	9.00	0.3543	81.0	125.0	9.00
A9009.5	–	9.50	0.3740	81.0	125.0	9.50
A9003/8	3/8	9.52	0.3750	92.0	127.0	9.52
A90010.0	–	10.00	0.3937	87.0	133.0	10.00
A90010.2	–	10.20	0.4016	87.0	133.0	10.20
A90010.3	–	10.30	0.4055	87.0	133.0	10.30
A90010.5	–	10.50	0.4134	87.0	133.0	10.50
A90011.0	–	11.00	0.4331	94.0	142.0	11.00
A90011.5	–	11.50	0.4528	94.0	142.0	11.50
A90011.8	–	11.80	0.4646	94.0	142.0	11.80
A90015/32	15/32	11.91	0.4688	110.0	146.0	11.91
A90012.0	–	12.00	0.4724	101.0	151.0	12.00
A90031/64	31/64	12.30	0.4844	111.0	149.0	12.30
A90012.5	–	12.50	0.4921	101.0	151.0	12.50
A9001/2	1/2	12.70	0.5000	101.0	151.0	12.70
A90013.0	–	13.00	0.5118	101.0	151.0	13.00
A90013.5	–	13.50	0.5315	108.0	160.0	13.50
A90014.0	–	14.00	0.5512	108.0	160.0	14.00
A9009/16	9/16	14.29	0.5625	122.0	168.0	14.29
A90015.0	–	15.00	0.5906	114.0	169.0	15.00
A90016.0	–	16.00	0.6299	120.0	178.0	16.00
A90017.0	–	17.00	0.6693	125.0	184.0	17.00
A90011/16	11/16	17.46	0.6875	143.0	194.0	17.46
A90018.0	–	18.00	0.7087	130.0	191.0	18.00
A90023/32	23/32	18.26	0.7188	130.0	191.0	18.26
A90018.5	–	18.50	0.7283	135.0	198.0	18.50
A90047/64	47/64	18.65	0.7344	135.0	198.0	18.65
A9003/4	3/4	19.05	0.7500	135.0	198.0	19.05
A90049/64	49/64	19.45	0.7656	135.0	198.0	19.45
A90019.5	–	19.50	0.7677	140.0	205.0	19.50
A90025/32	25/32	19.84	0.7813	140.0	205.0	19.84
A90020.0	–	20.00	0.7874	140.0	205.0	20.00

A940



Foret série longue PFX en HSS-E (5% cobalt), finition brillante

Foret haute performance capable de produire des trous de haute qualité et précis à des vitesses et des avances élevées (tolérance de trou H10). Sa pointe auto-centrante à 130° et la conception spéciale de sa goujure parabolique permettent de percer des trous très profonds en une seule passe. Convient à de nombreux matériaux.

PFX

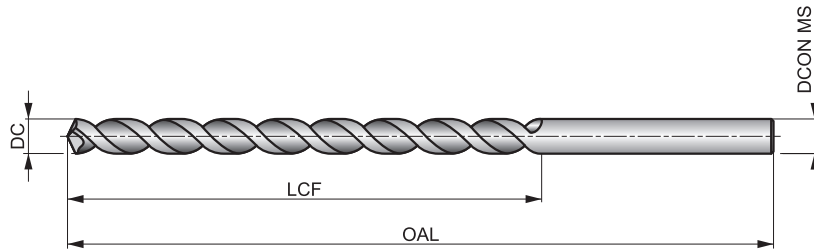

HSS-E	DIN ANSI	10xD
130°	Bright	
λ > 35°		DC h8

Adéquation du groupe de matériaux de la pièce, valeurs de départ pour la vitesse de coupe (m/min) et code Alpha d'avance. Les tableaux d'avances par tour se trouvent à partir de la page 274.

P1.1 ■ 29 F	P1.2 ■ 33 F	P1.3 ■ 34 F	P2.1 ■ 25 F	P2.2 ■ 22 G	P2.3 ■ 19 C	P3.1 ■ 25 G	P3.2 ■ 20 G	P3.3 ■ 17 C	P4.1 ■ 15 G	P4.2 ■ 13 C	P4.3 ■ 10 C	M1.1 ■ 21 C	M1.2 ■ 17 C
M2.1 ■ 18 C	M2.2 ■ 15 C	M3.1 ■ 8 E	M3.2 ■ 7 E	M3.3 ■ 6 E	M4.1 ■ 9 B	K2.1 ▣ 20 I	K2.2 ▣ 16 I	K2.3 ▣ 13 H	K3.1 ▣ 17 I	K3.2 ▣ 13 I	K3.3 ▣ 11 H	K4.1 ▣ 16 I	K4.2 ▣ 12 I
K4.3 ▣ 9 H	K4.4 ▣ 18 H	K4.5 ▣ 6 H	K5.1 ▣ 18 I	K5.2 ▣ 14 I	K5.3 ▣ 11 H	N1.1 ▣ 53 H	N1.2 ▣ 40 H	N1.3 ■ 27 N	N2.1 ▣ 62 N	N2.2 ▣ 55 N	N2.3 ▣ 40 N	N3.1 ▣ 119 G	N3.2 ▣ 70 F
N3.3 ▣ 35 F	N4.1 ▣ 55 H	N4.2 ▣ 40 F	S1.1 ■ 18 E	S1.2 ■ 13 C	S1.3 ■ 6 C								

DC >= 9.6mm moins de 10xD.

Product	DC (inch)	DC (mm)	DC (inch)	LCF (mm)	OAL (mm)	DCON MS (mm)
A9401.0	–	1.00	0.0394	33.0	56.0	1.00
A9401.1	–	1.10	0.0433	37.0	60.0	1.10
A9403/64	3/64	1.19	0.0469	29.0	57.0	1.19
A9401.2	–	1.20	0.0472	41.0	65.0	1.20
A9401.3	–	1.30	0.0512	41.0	65.0	1.30
A9401.4	–	1.40	0.0551	45.0	70.0	1.40
A9401.5	–	1.50	0.0591	45.0	70.0	1.50
A9401/16	1/16	1.59	0.0625	44.0	76.0	1.59
A9401.6	–	1.60	0.0630	50.0	76.0	1.60
A9401.7	–	1.70	0.0669	50.0	76.0	1.70
A9401.8	–	1.80	0.0709	53.0	80.0	1.80
A9401.9	–	1.90	0.0748	53.0	80.0	1.90
A9405/64	5/64	1.98	0.0781	51.0	95.0	1.98
A9402.0	–	2.00	0.0787	56.0	85.0	2.00
A9402.1	–	2.10	0.0827	56.0	85.0	2.10
A9402.2	–	2.20	0.0866	59.0	90.0	2.20
A9402.3	–	2.30	0.0906	59.0	90.0	2.30
A9403/32	3/32	2.38	0.0938	57.0	108.0	2.38
A9402.4	–	2.40	0.0945	62.0	95.0	2.40
A9402.5	–	2.50	0.0984	62.0	95.0	2.50
A9402.6	–	2.60	0.1024	62.0	95.0	2.60
A9402.7	–	2.70	0.1063	66.0	100.0	2.70
A9407/64	7/64	2.78	0.1094	64.0	117.0	2.78
A9402.8	–	2.80	0.1102	66.0	100.0	2.80
A9402.9	–	2.90	0.1142	66.0	100.0	2.90

Product	DC (inch)	DC (mm)	DC (inch)	LCF (mm)	OAL (mm)	DCON MS (mm)
A9403.0	–	3.00	0.1181	66.0	100.0	3.00
A9403.1	–	3.10	0.1220	69.0	106.0	3.10
A9401/8	1/8	3.18	0.1250	70.0	130.0	3.18
A9403.2	–	3.20	0.1260	69.0	106.0	3.20
A9403.3	–	3.30	0.1299	69.0	106.0	3.30
A9403.4	–	3.40	0.1339	73.0	112.0	3.40
A9403.5	–	3.50	0.1378	73.0	112.0	3.50
A9409/64	9/64	3.57	0.1406	76.0	137.0	3.57
A9403.6	–	3.60	0.1417	73.0	112.0	3.60
A9403.7	–	3.70	0.1457	73.0	112.0	3.70
A9403.8	–	3.80	0.1496	78.0	119.0	3.80
A9403.9	–	3.90	0.1535	78.0	119.0	3.90
A9405/32	5/32	3.97	0.1563	76.0	137.0	3.97
A9404.0	–	4.00	0.1575	78.0	119.0	4.00
A9404.1	–	4.10	0.1614	78.0	119.0	4.10
A9404.2	–	4.20	0.1654	78.0	119.0	4.20
A9404.3	–	4.30	0.1693	82.0	126.0	4.30
A9404.4	–	4.40	0.1732	82.0	126.0	4.40
A9404.5	–	4.50	0.1772	82.0	126.0	4.50
A9404.6	–	4.60	0.1811	82.0	126.0	4.60
A9403/16	3/16	4.76	0.1875	86.0	146.0	4.76
A9404.8	–	4.80	0.1890	87.0	132.0	4.80
A9404.9	–	4.90	0.1929	87.0	132.0	4.90
A9405.0	–	5.00	0.1969	87.0	132.0	5.00
A9405.1	–	5.10	0.2008	87.0	132.0	5.10



Product	DC	DC	DC	LCF	OAL	DCON MS
	(inch)	(mm)	(inch)	(mm)	(mm)	(mm)
A9405.2	–	5.20	0.2047	87.0	132.0	5.20
A9405.3	–	5.30	0.2087	87.0	132.0	5.30
A9405.4	–	5.40	0.2126	91.0	139.0	5.40
A9405.5	–	5.50	0.2165	91.0	139.0	5.50
A9405.8	–	5.80	0.2283	91.0	139.0	5.80
A9405.9	–	5.90	0.2323	91.0	139.0	5.90
A9406.0	–	6.00	0.2362	91.0	139.0	6.00
A9406.1	–	6.10	0.2402	97.0	148.0	6.10
A9406.2	–	6.20	0.2441	97.0	148.0	6.20
A9401/4	1/4	6.35	0.2500	95.0	156.0	6.35
A9406.4	–	6.40	0.2520	97.0	148.0	6.40
A9406.5	–	6.50	0.2559	97.0	148.0	6.50
A9406.6	–	6.60	0.2598	97.0	148.0	6.60
A9406.7	–	6.70	0.2638	97.0	148.0	6.70
A94017/64	17/64	6.75	0.2656	98.0	159.0	6.75
A9406.8	–	6.80	0.2677	102.0	156.0	6.80
A9406.9	–	6.90	0.2717	102.0	156.0	6.90
A9407.0	–	7.00	0.2756	102.0	156.0	7.00
A9407.2	–	7.20	0.2835	102.0	156.0	7.20
A9407.3	–	7.30	0.2874	102.0	156.0	7.30
A9407.5	–	7.50	0.2953	102.0	156.0	7.50
A9407.8	–	7.80	0.3071	109.0	165.0	7.80
A9405/16	5/16	7.94	0.3125	102.0	162.0	7.94
A9408.0	–	8.00	0.3150	109.0	165.0	8.00
A9408.2	–	8.20	0.3228	109.0	165.0	8.20
A9408.3	–	8.30	0.3268	109.0	165.0	8.30
A9408.5	–	8.50	0.3346	109.0	165.0	8.50
A9408.6	–	8.60	0.3386	115.0	175.0	8.60
A9408.7	–	8.70	0.3425	115.0	175.0	8.70
A94011/32	11/32	8.73	0.3438	105.0	165.0	8.73

Product	DC	DC	DC	LCF	OAL	DCON MS
	(inch)	(mm)	(inch)	(mm)	(mm)	(mm)
A9409.0	–	9.00	0.3543	115.0	175.0	9.00
A9409.5	–	9.50	0.3740	115.0	175.0	9.50
A9409.8	–	9.80	0.3858	121.0	184.0	9.80
A94010.0	–	10.00	0.3937	121.0	184.0	10.00
A94010.2	–	10.20	0.4016	121.0	184.0	10.20
A94010.3	–	10.30	0.4055	121.0	184.0	10.30
A94013/32	13/32	10.32	0.4063	111.0	178.0	10.32
A94010.5	–	10.50	0.4134	121.0	184.0	10.50
A94027/64	27/64	10.72	0.4219	117.0	184.0	10.72
A94011.0	–	11.00	0.4331	128.0	195.0	11.00
A9407/16	7/16	11.11	0.4375	117.0	184.0	11.11
A94011.5	–	11.50	0.4528	128.0	195.0	11.50
A94029/64	29/64	11.51	0.4531	121.0	190.0	11.51
A94011.8	–	11.80	0.4646	128.0	195.0	11.80
A94012.0	–	12.00	0.4724	134.0	205.0	12.00
A94012.2	–	12.20	0.4803	134.0	205.0	12.20
A94031/64	31/64	12.30	0.4844	121.0	197.0	12.30
A94012.5	–	12.50	0.4921	134.0	205.0	12.50
A94013.0	–	13.00	0.5118	134.0	205.0	13.00
A94017/32	17/32	13.49	0.5313	121.0	203.0	13.49
A94014.0	–	14.00	0.5512	140.0	214.0	14.00
A9409/16	9/16	14.29	0.5625	124.0	210.0	14.29
A94014.5	–	14.50	0.5709	144.0	220.0	14.50
A94015.0	–	15.00	0.5906	144.0	220.0	15.00
A94015.5	–	15.50	0.6102	149.0	227.0	15.50
A94016.0	–	16.00	0.6299	149.0	227.0	16.00
A94021/32	21/32	16.67	0.6563	130.0	229.0	16.67
A94017.0	–	17.00	0.6693	154.0	235.0	17.00
A94011/16	11/16	17.46	0.6875	137.0	235.0	17.46
A94019.0	–	19.00	0.7480	162.0	247.0	19.00

A976



Foret extra-long PFX en HSS-E (5% cobalt) (DIN 1869 série 1), finition brillante

Foret recommandé pour le perçage de trous très profonds ou pour les applications où une très longue portée est nécessaire. Les goujures paraboliques spécialement conçues éliminent le besoin de percer des trous profonds par petites étapes (débourrage). Pointe à 130°. Le centrage avec un foret PFX court 3xD est recommandé (pour garder la même tolérance sur DC). Convient pour le perçage de nombreux matériaux.

PFX

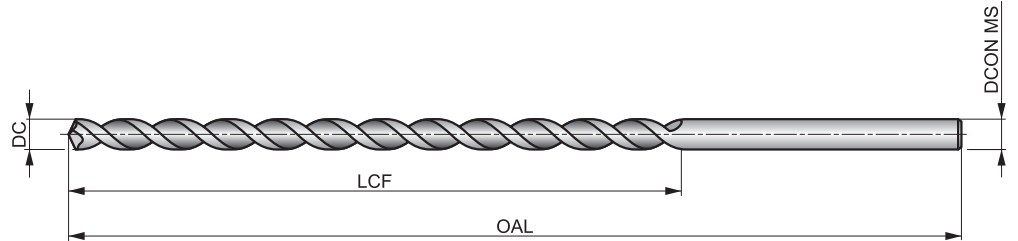

HSS-E	DIN 1869-1	15×D
130°	Bright	
λ>35°	R	DC h8

Adéquation du groupe de matériaux de la pièce, valeurs de départ pour la vitesse de coupe (m/min) et code Alpha d'avance. Les tableaux d'avances par tour se trouvent à partir de la page 274.

P1.1 29 C	P1.2 33 C	P1.3 34 C	P2.1 25 C	P2.2 22 C	P2.3 19 A	P3.1 18 C	P3.2 14 C	P3.3 12 A	P4.1 11 C	P4.2 9 A	P4.3 7 A	M1.1 16 B	M1.2 14 B
M2.1 15 B	M2.2 12 B	M3.1 8 C	M3.2 7 C	M3.3 6 C	M4.1 8 A	K2.1 20 C	K2.2 16 C	K2.3 13 A	K3.1 17 C	K3.2 13 C	K3.3 11 A	K4.1 16 C	K4.2 12 C
K4.3 19 A	K4.4 8 A	K4.5 6 A	K5.1 18 C	K5.2 14 C	K5.3 11 A	N3.1 30 D	S1.1 15 C	S1.2 11 A	S1.3 5 A				

Product	DC (inch)	DC (mm)	DC (inch)	LCF (mm)	OAL (mm)	DCON MS (mm)
A9761.5	–	1.50	0.0591	75.0	115.0	1.50
A9762.0X125	–	2.00	0.0787	85.0	125.0	2.00
A9762.1X125	–	2.10	0.0827	85.0	125.0	2.10
A9762.2X135	–	2.20	0.0866	90.0	135.0	2.20
A9762.3X135	–	2.30	0.0906	90.0	135.0	2.30
A9762.4X140	–	2.40	0.0945	95.0	140.0	2.40
A9762.5X140	–	2.50	0.0984	95.0	140.0	2.50
A9762.6X140	–	2.60	0.1024	95.0	140.0	2.60
A9762.7X150	–	2.70	0.1063	100.0	150.0	2.70
A9762.8X150	–	2.80	0.1102	100.0	150.0	2.80
A9762.9X150	–	2.90	0.1142	100.0	150.0	2.90
A9763.0X150	–	3.00	0.1181	100.0	150.0	3.00
A9763.1X155	–	3.10	0.1220	105.0	155.0	3.10
A9761/8	1/8	3.18	0.1250	105.0	155.0	3.18
A9763.2X155	–	3.20	0.1260	105.0	155.0	3.20
A9763.3X155	–	3.30	0.1299	105.0	155.0	3.30
A9763.4X165	–	3.40	0.1339	115.0	165.0	3.40
A9763.5X165	–	3.50	0.1378	115.0	165.0	3.50
A9763.6X165	–	3.60	0.1417	115.0	165.0	3.60
A9763.7X165	–	3.70	0.1457	115.0	165.0	3.70
A9763.8X175	–	3.80	0.1496	120.0	175.0	3.80
A9763.9X175	–	3.90	0.1535	120.0	175.0	3.90
A9765/32	5/32	3.97	0.1563	120.0	175.0	3.97
A9764.0X175	–	4.00	0.1575	120.0	175.0	4.00
A9764.1X175	–	4.10	0.1614	120.0	175.0	4.10
A9764.2X175	–	4.20	0.1654	120.0	175.0	4.20
A9764.3X185	–	4.30	0.1693	125.0	185.0	4.30
A9764.5X185	–	4.50	0.1772	125.0	185.0	4.50
A9764.6X185	–	4.60	0.1811	125.0	185.0	4.60
A9764.7X185	–	4.70	0.1850	125.0	185.0	4.70
A9763/16	3/16	4.76	0.1875	135.0	195.0	4.76
A9764.8X195	–	4.80	0.1890	135.0	195.0	4.80
A9765.0X195	–	5.00	0.1969	135.0	195.0	5.00

Product	DC (inch)	DC (mm)	DC (inch)	LCF (mm)	OAL (mm)	DCON MS (mm)
A9765.1X195	–	5.10	0.2008	135.0	195.0	5.10
A9765.2X195	–	5.20	0.2047	135.0	195.0	5.20
A9765.3X195	–	5.30	0.2087	135.0	195.0	5.30
A9765.5X205	–	5.50	0.2165	140.0	205.0	5.50
A9765.7X205	–	5.70	0.2244	140.0	205.0	5.70
A9765.8X205	–	5.80	0.2283	140.0	205.0	5.80
A9765.9X205	–	5.90	0.2323	140.0	205.0	5.90
A9766.0X205	–	6.00	0.2362	140.0	205.0	6.00
A9766.1X215	–	6.10	0.2402	150.0	215.0	6.10
A9766.2X215	–	6.20	0.2441	150.0	215.0	6.20
A9761/4	1/4	6.35	0.2500	150.0	215.0	6.35
A9766.4X215	–	6.40	0.2520	150.0	215.0	6.40
A9766.5X215	–	6.50	0.2559	150.0	215.0	6.50
A9766.7X215	–	6.70	0.2638	150.0	215.0	6.70
A9766.8X225	–	6.80	0.2677	155.0	225.0	6.80
A9767.0X225	–	7.00	0.2756	155.0	225.0	7.00
A9767.5X225	–	7.50	0.2953	155.0	225.0	7.50
A9765/16	5/16	7.94	0.3125	165.0	240.0	7.94
A9768.0X240	–	8.00	0.3150	165.0	240.0	8.00
A9768.5X240	–	8.50	0.3346	165.0	240.0	8.50
A97611/32	11/32	8.73	0.3438	175.0	250.0	8.73
A9769.0X250	–	9.00	0.3543	175.0	250.0	9.00
A9769.5X250	–	9.50	0.3740	175.0	250.0	9.50
A9763/8	3/8	9.52	0.3750	185.0	265.0	9.52
A97610.0X265	–	10.00	0.3937	185.0	265.0	10.00
A97610.5	–	10.50	0.4134	185.0	265.0	10.50
A97611.0	–	11.00	0.4331	195.0	280.0	11.00
A9767/16	7/16	11.11	0.4375	195.0	280.0	11.11
A97611.5	–	11.50	0.4528	195.0	280.0	11.50
A97612.0	–	12.00	0.4724	205.0	295.0	12.00
A97612.5	–	12.50	0.4921	205.0	295.0	12.50
A97613.0	–	13.00	0.5118	205.0	295.0	13.00
A97614.0 ¹⁾	–	14.00	0.5512	215.0	310.0	14.00

A977



Foret extra-long PFX en HSS-E (5% cobalt) (DIN 1869 série 2), finition brillante

Foret recommandé pour le perçage de trous très profonds et dans les applications où une très longue portée est nécessaire. Les goujures paraboliques spécialement conçues éliminent le besoin de percer des trous profonds par petites étapes (débouillage). Pointe à 130°. Le centrage avec un foret PFX court 3xD est recommandé (pour garder la même tolérance sur DC). Convient pour le perçage de nombreux matériaux.

PFX

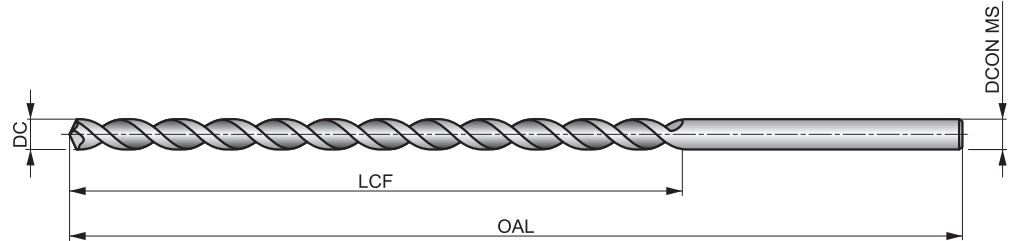

HSS-E	DIN 1869-2	20xD
130°	Bright	
λ>35°	R	DC h8

Adéquation du groupe de matériaux de la pièce, valeurs de départ pour la vitesse de coupe (m/min) et code Alpha d'avance. Les tableaux d'avances par tour se trouvent à partir de la page 274.

P1.1 ▣29 B	P1.2 ▣33 B	P1.3 ▣34 B	P2.1 ▣25 B	P2.2 ▣22 B	P2.3 ▣19 A	P3.1 ▣18 B	P3.2 ▣14 B	P3.3 ▣12 A	P4.1 ▣11 B	P4.2 ▣9 A	P4.3 ▣7 A	M1.1 ▣16 B	M1.2 ▣14 B
M2.1 ▣15 B	M2.2 ▣12 B	M3.1 ▣8 B	M3.2 ▣7 B	M3.3 ▣6 B	M4.1 ▣8 A	K2.1 ▣20 B	K2.2 ▣16 B	K2.3 ▣13 A	K3.1 ▣17 B	K3.2 ▣13 B	K3.3 ▣11 A	K4.1 ▣16 B	K4.2 ▣12 B
K4.3 ▣9 A	K4.4 ▣8 A	K4.5 ▣6 A	K5.1 ▣18 B	K5.2 ▣14 B	K5.3 ▣11 A	N3.1 ▣30 C	S1.1 ▣15 B	S1.2 ▣11 A	S1.3 ▣5 A				

Product	DC (inch)	DC (mm)	DC (inch)	LCF (mm)	OAL (mm)	DCON MS (mm)
A9771.5 ¹⁾	—	1.50	0.0591	100.0	150.0	1.50
A9771/16 ¹⁾	1/16	1.59	0.0625	100.0	150.0	1.59
A9772.0 ¹⁾	—	2.00	0.0787	110.0	160.0	2.00
A9773/32 ¹⁾	3/32	2.38	0.0938	115.0	170.0	2.38
A9773.0X190	—	3.00	0.1181	130.0	190.0	3.00
A9771/8	1/8	3.18	0.1250	135.0	200.0	3.18
A9773.5X210	—	3.50	0.1378	145.0	210.0	3.50
A9774.0X220	—	4.00	0.1575	150.0	220.0	4.00
A9774.5X235	—	4.50	0.1772	160.0	235.0	4.50
A9773/16	3/16	4.76	0.1875	170.0	245.0	4.76
A9775.0X245	—	5.00	0.1969	170.0	245.0	5.00
A9775.5X260	—	5.50	0.2165	180.0	260.0	5.50
A9776.0X260	—	6.00	0.2362	180.0	260.0	6.00
A9771/4	1/4	6.35	0.2500	190.0	275.0	6.35

Product	DC (inch)	DC (mm)	DC (inch)	LCF (mm)	OAL (mm)	DCON MS (mm)
A9776.5X275	—	6.50	0.2559	190.0	275.0	6.50
A9777.0X290	—	7.00	0.2756	200.0	290.0	7.00
A9778.0X305	—	8.00	0.3150	210.0	305.0	8.00
A9778.5X305	—	8.50	0.3346	210.0	305.0	8.50
A9779.0X320	—	9.00	0.3543	220.0	320.0	9.00
A9779.5X320	—	9.50	0.3740	220.0	320.0	9.50
A97710.0X340	—	10.00	0.3937	235.0	340.0	10.00
A97710.5	—	10.50	0.4134	235.0	340.0	10.50
A97711.0	—	11.00	0.4331	250.0	365.0	11.00
A97711.5	—	11.50	0.4528	250.0	365.0	11.50
A97712.0	—	12.00	0.4724	260.0	375.0	12.00
A97712.5	—	12.50	0.4921	260.0	375.0	12.50
A97713.0	—	13.00	0.5118	260.0	375.0	13.00
A97714.0 ¹⁾	—	14.00	0.5512	270.0	390.0	14.00

¹⁾ Standard Dormer.

A978



Foret extra-long PFX en HSS-E (5% cobalt) (DIN 1869 série 3), finition brillante

Foret recommandé pour les trous extra profonds et pour les applications nécessitant une plus grande portée. Les goujures paraboliques spécialement conçues éliminent le besoin de percer des trous profonds par petites étapes (déburrage). Pointe à 130°. Le centrage avec un foret PFX court 3xD est recommandé (pour garder la même tolérance sur DC). Convient pour le perçage de nombreux matériaux.

PFX

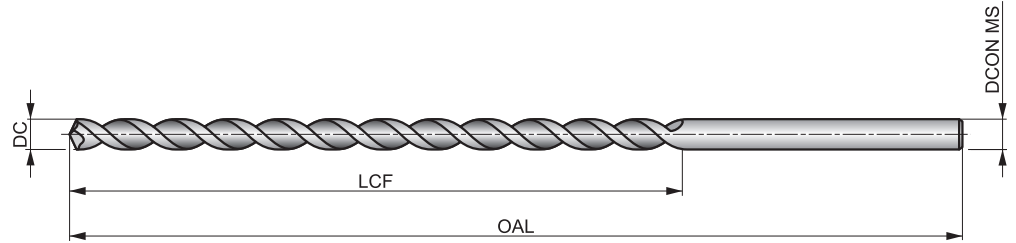

HSS-E	DIN 1869-3	25xD
130°	Bright	
λ>35°	R	DC h8

Adéquation du groupe de matériaux de la pièce, valeurs de départ pour la vitesse de coupe (m/min) et code Alpha d'avance. Les tableaux d'avances par tour se trouvent à partir de la page 274.

P1.1 ▣29 A	P1.2 ▣33 A	P1.3 ▣34 A	P2.1 ▣25 A	P2.2 ▣22 A	P2.3 ▣19 A	P3.1 ▣18 A	P3.2 ▣14 A	P3.3 ▣12 A	P4.1 ▣11 A	P4.2 ▣9 A	P4.3 ▣7 A	M1.1 ▣16 A	M1.2 ▣14 A
M2.1 ▣15 A	M2.2 ▣12 A	M3.1 ▣8 A	M3.2 ▣7 A	M3.3 ▣6 A	M4.1 ▣8 A	K2.1 ▣20 A	K2.2 ▣16 A	K2.3 ▣13 A	K3.1 ▣17 A	K3.2 ▣13 A	K3.3 ▣11 A	K4.1 ▣16 A	K4.2 ▣12 A
K4.3 ▣9 A	K4.4 ▣8 A	K4.5 ▣6 A	K5.1 ▣18 A	K5.2 ▣14 A	K5.3 ▣11 A	N3.1 ▣30 B	S1.1 ▣15 A	S1.2 ▣11 A	S1.3 ▣5 A				

Product	DC	DC	DC	LCF	OAL	DCON MS
	(inch)	(mm)	(inch)			
A9783.0 ¹⁾	–	3.00	0.1181	160.0	240.0	3.00
A9783.5X265	–	3.50	0.1378	180.0	265.0	3.50
A9784.0X280	–	4.00	0.1575	190.0	280.0	4.00
A9784.5X295	–	4.50	0.1772	200.0	295.0	4.50
A9785.0X315	–	5.00	0.1969	210.0	315.0	5.00
A9786.0X330	–	6.00	0.2362	225.0	330.0	6.00
A9781/4	1/4	6.35	0.2500	235.0	350.0	6.35
A9786.5X350	–	6.50	0.2559	235.0	350.0	6.50
A9787.0X370	–	7.00	0.2756	250.0	370.0	7.00
A9788.0X390	–	8.00	0.3150	265.0	390.0	8.00
A9788.5X390	–	8.50	0.3346	265.0	390.0	8.50
A9789.0X410	–	9.00	0.3543	280.0	410.0	9.00
A9789.5X410	–	9.50	0.3740	280.0	410.0	9.50
A97810.0X430	–	10.00	0.3937	295.0	430.0	10.00

¹⁾ Standard Dormer.

A952



Foret à queue cône morse (DIN 1870 série 2) série extra longue PFX en HSS, finition brillante

Foret polyvalent avec une conception spéciale de goujure parabolique pour percer des trous profonds en un seul passage. Le foret a une pointe auto-centrante à 130° (le centrage avec un foret PFX court est recommandé) de sorte que la force nécessaire pour percer le trou est réduite. Convient pour percer de nombreux matériaux.

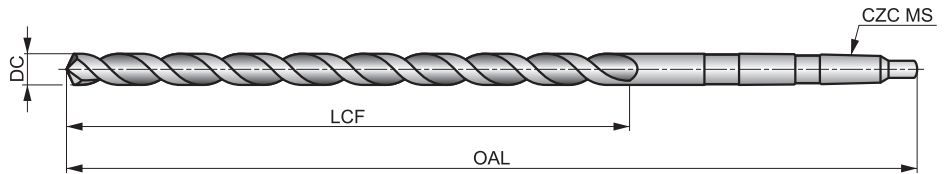

HSS	DIN 1870(2)	20xD
130°	Bright ST	
$\lambda > 35^\circ$	R	DC h8

Adéquation du groupe de matériaux de la pièce, valeurs de départ pour la vitesse de coupe (m/min) et code Alpha d'avance. Les tableaux d'avances par tour se trouvent à partir de la page 274.

P1.1 ■ 25 G	P1.2 ■ 28 G	P1.3 ■ 29 G	P2.1 ■ 22 G	P2.2 ■ 19 E	P2.3 ■ 17 C	P3.1 ■ 12 D	P3.2 ■ 9 D	P3.3 ■ 8 C	P4.1 ■ 7 D	P4.2 ■ 6 C	P4.3 ■ 5 B	M1.1 ■ 16 C	M1.2 ■ 14 C
M2.1 ■ 15 C	M2.2 ■ 12 C	M3.1 ■ 17 E	M3.2 ■ 16 E	M3.3 ■ 15 E	M4.1 ■ 12 A	K1.1 ■ 22 G	K1.2 ■ 16 D	K1.3 ■ 12 D	K2.1 ■ 16 C	K2.2 ■ 13 C	K2.3 ■ 10 C	K3.1 ■ 14 C	K3.2 ■ 11 C
K3.3 ■ 9 C	K4.1 ■ 13 C	K4.2 ■ 10 C	K4.3 ■ 7 C	K4.4 ■ 6 C	K4.5 ■ 5 C	K5.1 ■ 15 C	K5.2 ■ 11 C	K5.3 ■ 9 C	N1.1 ■ 30 H	N1.2 ■ 23 H	N1.3 ■ 15 G	N2.1 ■ 37 F	N2.2 ■ 33 F
N2.3 ■ 24 F	N3.1 ■ 56 F	N3.2 ■ 33 G	N3.3 ■ 17 D	N4.1 ■ 30 J	N4.2 ■ 30 H	N4.3 ■ 10 F	S1.1 ■ 18 D	S1.2 ■ 10 B	S1.3 ■ 6 A	S2.1 ■ 7 C	S2.2 ■ 4 A	S3.1 ■ 5 C	S3.2 ■ 3 A
S4.1 ■ 4 C	S4.2 ■ 2 A												

DC >= 14.5mm moins de 20xD; DC > 23mm Brillant.

Product	DC (mm)	DC (inch)	LCF (mm)	OAL (mm)	CZC MS
A9528.0	8.00	0.3150	210.0	330.0	MK 1
A9529.0	9.00	0.3543	220.0	345.0	MK 1
A95210.0	10.00	0.3937	235.0	360.0	MK 1
A95211.0	11.00	0.4331	250.0	375.0	MK 1
A95213.0	13.00	0.5118	260.0	395.0	MK 1
A95214.0	14.00	0.5512	275.0	410.0	MK 1
A95215.0	15.00	0.5906	275.0	425.0	MK 2
A95216.0	16.00	0.6299	295.0	445.0	MK 2
A95217.0	17.00	0.6693	295.0	445.0	MK 2
A95219.0	19.00	0.7480	310.0	465.0	MK 2

Product	DC (mm)	DC (inch)	LCF (mm)	OAL (mm)	CZC MS
A95220.0	20.00	0.7874	325.0	490.0	MK 2
A95221.0	21.00	0.8268	325.0	490.0	MK 2
A95223.0	23.00	0.9055	345.0	515.0	MK 2
A95224.0	24.00	0.9449	365.0	555.0	MK 3
A95225.0	25.00	0.9843	365.0	555.0	MK 3
A95226.0	26.00	1.0236	365.0	555.0	MK 3
A95227.0	27.00	1.0630	385.0	580.0	MK 3
A95228.0	28.00	1.1024	385.0	580.0	MK 3
A95229.0	29.00	1.1417	385.0	580.0	MK 3
A95230.0	30.00	1.1811	385.0	580.0	MK 3

Code de matériau du corps (BMC)	HSS	HSS	HSS	HSS	HSS	HSS	HSS	HSS	HSS	HSS	HSS
Groupe standard de base (BSG)	DORMER	DIN 373	ANSI	ANSI	ANSI	ANSI	ANSI	DIN 8374	DIN 8376	DORMER	DORMER
Rapport longueur utile diamètre (ULDR)								4×D	4×D	2.5×D	2.5×D
Angle d'application	20°	180°						90°	180°	180°	90°
Revêtement	Bright	Bright	Bright	Bright	Bright	Bright	Bright	ST	ST	ST	ST
Queue											
Forme de spirale								λ 20-35°	λ 20-35°		
Sens (direction de coupe)	R	R	R	R		R	R	R	R	R	R

Code de famille de produits	G314	G125	G702	G703	G704	G705	G706	A400	A402	A413	A412
Plage de diamètres de coupe PSF	4.00 - 9.00	6.50 - 20.00	1/4 - 2"	1/2 - 2.1/8	1/8 - 1.1/2	1/4 - 15/16	1/4 - 1"	M3 - M8	M3 - M10	M3 - M10	M3 - M10

P	P1	■	■	■	■	■	■	■	■	■	■
	P2	☑	■	■	■	■	■	■	■	■	■
	P3	☑	☑	■	■	■	■	■	■	■	■
	P4	■	☑	☑	☑	■	☑	☑	☑	☑	☑
M	M1	☑	☑	☑	☑	☑	☑	☑	☑	■	■
	M2	☑	☑	☑	☑	☑	☑	☑	☑	■	■
	M3	■	■	■	■	■	■	☑	☑	☑	☑
	M4	■	■	■	■	■	■	☑	☑	☑	☑
K	K1	☑	☑	■	■	■	■	■	■	■	■
	K2	■	☑	■	■	■	■	☑	☑	☑	☑
	K3	■	☑	☑	☑	☑	☑	☑	☑	☑	☑
	K4	■	☑	☑	☑	☑	☑	☑	☑	☑	☑
	K5	■	☑	■	■	■	■	☑	☑	☑	☑
N	N1	■	■	■	■	■	■	☑	☑	☑	☑
	N2	☑	☑	☑	☑	☑	☑	☑	☑	☑	☑
	N3	■	■	■	■	■	■	☑	☑	☑	☑
	N4	■	☑	■	■	■	■	☑	☑	☑	☑
	N5	■	■	■	■	■	■	■	■	■	■
S	S1	■	■	■	■	■	■	☑	☑	☑	☑
	S2	■	■	■	■	■	■	☑	☑	☑	☑
	S3	■	■	■	■	■	■	☑	☑	☑	☑
	S4	■	■	■	■	■	■	☑	☑	☑	☑
H	H1	■	■	■	■	■	■	■	■	■	■
	H2	■	■	■	■	■	■	■	■	■	■
	H3	■	■	■	■	■	■	■	■	■	■
	H4	■	■	■	■	■	■	■	■	■	■

G314



Foret étagé conique en HSS à coupe pour matériaux en feuilles minces, finition brillante

Forets étagé à coupe conique ayant plusieurs diamètres qui permettent d'agrandir progressivement les trous jusqu'au diamètre requis. La queue cylindrique réduite permet de maintenir tous les diamètres dans un mandrin et un support standard. Convient pour agrandir les trous dans de nombreux matériaux.

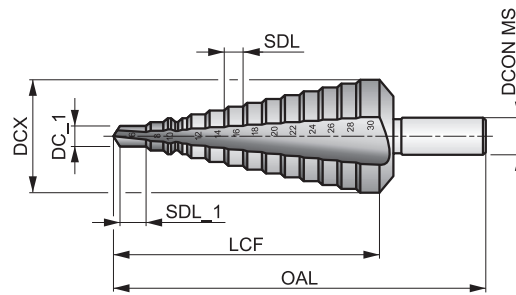

HSS	Bright	DORMER
R	20°	

Adéquation du groupe de matériaux de la pièce, valeurs de départ pour la vitesse de coupe (m/min) et code Alpha d'avance. Les tableaux d'avances par tour se trouvent à partir de la page 274.

P1.1 ■ 20	P1.2 ■ 22	P1.3 ■ 23	P2.1 ■ 17	P2.2 ■ 15	P2.3 ■ 13	P3.1 ■ 12	P3.2 ■ 9	M1.1 ■ 8	M1.2 ■ 6	M2.1 ■ 7	K1.1 ■ 17	N1.1 ■ 30	N1.2 ■ 23
N1.3 ■ 15	N2.1 ■ 31	N2.2 ■ 28	N3.1 ■ 34	N3.2 ■ 20	N3.3 ■ 10	N4.1 ■ 30	N4.2 ■ 20						

SDI = dimensions de chaque diamètre incrémenté.

Product	Nr.	DC_1 (mm)	DCX (mm)	SDL (mm)	SDI (mm)	SDL_1 (mm)	LCF (mm)	OAL (mm)	DCON MS (mm)
G314412	412	4.00	12.00	5.00	4 - 5 - 6 - 7 - 8 - 9 - 10 - 11 - 12	5.00	61.0	80.0	6.00
G3141220	1220	12.00	20.00	4.00	12 - 13 - 14 - 15 - 16 - 17 - 18 - 19 - 20	4.00	55.0	76.0	9.00
G3142030	2030	20.00	30.00	4.00	20 - 21 - 22 - 23 - 24 - 25 - 26 - 27 - 28 - 29 - 30	4.00	67.0	88.0	12.00
G3143040	3040	30.00	40.00	4.00	30 - 31 - 32 - 33 - 34 - 35 - 36 - 37 - 38 - 39 - 40	4.00	74.0	98.0	13.00
G314420	420	4.00	20.00	4.00	4 - 6 - 8 - 10 - 12 - 14 - 16 - 18 - 20	4.00	48.0	76.0	8.00
G314630	630	6.00	30.00	4.00	6 - 8 - 10 - 12 - 14 - 16 - 18 - 20 - 22 - 24 - 26 - 28 - 30	4.00	73.0	98.0	10.00
G314M	M	9.00	36.00	3.00	9 - 12 - 15 - 18 - 21 - 24 - 27 - 30 - 33 - 36	3.00	57.0	86.0	12.00

G125

DORMER



Fraise à lamer en HSS à 180° à queue cylindrique, finition brillante

Fraise à lamer avec un angle de 180° conçue pour créer les logements de vis à tête creuse et à tête cylindrique CHC standard. Elle est dotée d'un pilote solide (disponible pour différentes tolérances de taille de trou pré-usiné), qui aide à guider la fraise avec précision dans les trous de tailles métriques standards. Convient pour les lamages de trous dans de nombreux matériaux.

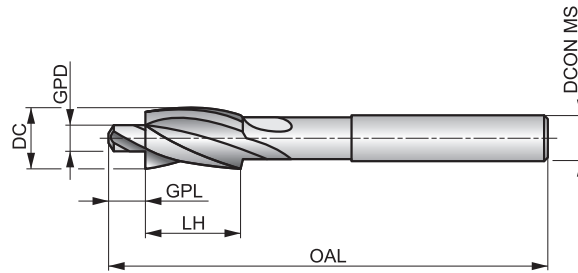

HSS	Bright	DIN 373
R	180°	

Adéquation du groupe de matériaux de la pièce, valeurs de départ pour la vitesse de coupe (m/min) et code Alpha d'avance. Les tableaux d'avances par tour se trouvent à partir de la page 274.

P1.1 ■ 20 E	P1.2 ■ 22 E	P1.3 ■ 23 E	P2.1 ■ 17 E	P2.2 ■ 15 D	P2.3 ■ 13 C	P3.1 ■ 12 D	P3.2 ■ 9 D	P3.3 ■ 8 C	P4.1 ■ 7 D	P4.2 ■ 6 C	M1.1 ■ 8 D	M1.2 ■ 6 D	M2.1 ■ 7 D
M2.2 ■ 6 D	M2.3 ■ 5 C	K1.1 ■ 17 E	K1.2 ■ 12 E	K1.3 ■ 11 E	K2.1 ■ 15 D	K2.2 ■ 12 D	K2.3 ■ 10 C	K3.1 ■ 13 D	K3.2 ■ 10 D	K4.1 ■ 12 D	K4.2 ■ 9 D	K5.1 ■ 14 D	K5.2 ■ 10 D
N1.1 ■ 30 G	N1.2 ■ 23 G	N1.3 ■ 15 G	N2.1 ■ 31 G	N2.2 ■ 28 G	N2.3 ■ 20 G	N3.1 ■ 34 C	N3.2 ■ 20 C	N3.3 ■ 10 C	N4.1 ■ 30 C	N4.2 ■ 20 C			

DCON MS tolérance h9.

Product	DC (mm)	GPD (mm)	CZC MS	GPL (mm)	OAL (mm)	LH (mm)	DCON MS (mm)	NOF
G1256.5X3.2 ¹⁾	6.50	3.20	M 3 f	4.50	71.0	14.0	5.00	3
G1256.5X3.4 ²⁾	6.50	3.40	M 3 m	4.50	71.0	14.0	5.00	3
G1258.0X3.3 ³⁾	8.00	3.30	M 4 t	5.00	71.0	14.0	5.00	3
G1258.0X4.3 ¹⁾	8.00	4.30	M 4 f	5.00	71.0	14.0	5.00	3
G1258.0X4.5 ²⁾	8.00	4.50	M 4 m	5.00	71.0	14.0	5.00	3
G12510.0X4.2 ³⁾	10.00	4.20	M 5 t	5.50	80.0	18.0	8.00	3
G12510.0X5.3 ¹⁾	10.00	5.30	M 5 f	5.50	80.0	18.0	8.00	3
G12510.0X5.5 ²⁾	10.00	5.50	M 5 m	5.50	80.0	18.0	8.00	3
G12511.0X5.0 ³⁾	11.00	5.00	M 6 t	6.00	80.0	18.0	8.00	3
G12511.0X6.4 ¹⁾	11.00	6.40	M 6 f	6.00	80.0	18.0	8.00	3
G12511.0X6.6 ²⁾	11.00	6.60	M 6 m	6.00	80.0	18.0	8.00	3
G12515.0X6.8 ³⁾	15.00	6.80	M 8 t	8.00	100.0	22.0	12.50	3
G12515.0X8.4 ¹⁾	15.00	8.40	M 8 f	8.00	100.0	22.0	12.50	3
G12515.0X9.0 ²⁾	15.00	9.00	M 8 m	8.00	100.0	22.0	12.50	3
G12518.0X8.5 ³⁾	18.00	8.50	M 10 t	10.00	100.0	22.0	12.50	3
G12518.0X10.5 ¹⁾	18.00	10.50	M 10 f	10.00	100.0	22.0	12.50	3
G12518.0X11.0 ²⁾	18.00	11.00	M 10 m	10.00	100.0	22.0	12.50	3
G12520.0X10.2 ³⁾	20.00	10.20	M 12 t	10.00	100.0	22.0	12.50	3
G12520.0X13.0 ¹⁾	20.00	13.00	M 12 f	10.00	100.0	22.0	12.50	3
G12520.0X13.5 ²⁾	20.00	13.50	M 12 m	10.00	100.0	22.0	12.50	3

¹⁾ f= pour trou de vis débouchant précis.

²⁾ m= pour trou de vis débouchant moyen.

³⁾ t= pour trou taraudé.

G702

DORMER



Corps de fraise à lamer HSS, avec queue réduite, type pilote amovible

Corps de fraise à lamer à queue cylindrique utilisé avec des pilotes amovibles pour réaliser un lamage à fond plat. Un pilote amovible non coupant G704 est monté dans le corps et suit le trou existant pour guider et centrer l'opération de lamage.

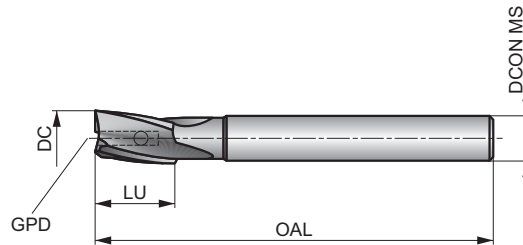

HSS	Bright	ANSI
R		

Adéquation du groupe de matériaux de la pièce, valeurs de départ pour la vitesse de coupe (m/min) et code Alpha d'avance. Les tableaux d'avances par tour se trouvent à partir de la page 274.

P1.1 ■ 20 E	P1.2 ■ 22 E	P1.3 ■ 23 E	P2.1 ■ 17 E	P2.2 ■ 15 D	P2.3 ■ 13 C	P3.1 ■ 12 D	P3.2 ■ 9 D	P3.3 ■ 8 C	P4.1 ■ 7 D	P4.2 ■ 6 C	P4.3 ■	M1.1 ■ 8 D	M1.2 ■ 6 D
M2.1 ■ 7 D	M2.2 ■ 6 D	M2.3 ■ 5 C	K1.1 ■ 17 E	K1.2 ■ 12 E	K1.3 ■ 11 E	K2.1 ■ 15 D	K2.2 ■ 12 D	K2.3 ■ 10 C	K3.1 ■ 13 D	K3.2 ■ 10 D	K4.1 ■ 12 D	K4.2 ■ 9 D	K5.1 ■ 14 D
K5.2 ■ 10 D	N1.1 ■ 30 G	N1.2 ■ 23 G	N1.3 ■ 15 G	N2.1 ■ 31 G	N2.2 ■ 28 G	N2.3 ■ 20 G	N3.1 ■ 34 C	N3.2 ■ 20 C	N3.3 ■ 10 C	N4.1 ■ 30 C	N4.2 ■ 20 C		

Product	DC (inch)	DC (inch)	LU (inch)	OAL (inch)	DCON MS (inch)	NOF	GPD (inch)	GPDN (inch)	GPDX (inch)
G7021/4	1/4	0.2500	3/4	3.13/16	15/64	3	3/32	1/8	3/16
G7029/32	9/32	0.2813	3/4	3.13/16	17/64	3	3/32	1/8	7/32
G7025/16	5/16	0.3125	3/4	3.13/16	19/64	3	3/32	1/8	1/4
G70211/32	11/32	0.3438	3/4	3.13/16	5/16	3	3/32	1/8	9/32
G7023/8	3/8	0.3750	1"	4.1/16	5/16	3	5/32	3/16	5/16
G70213/32	13/32	0.4063	1"	4.1/16	3/8	3	5/32	3/16	11/32
G7027/16	7/16	0.4375	1"	4.1/16	3/8	3	5/32	3/16	3/8
G70215/32	15/32	0.4688	1.1/4	4.5/16	7/16	3	3/16	3/16	13/32
G7021/2	1/2	0.5000	1.1/4	4.5/16	7/16	3	3/16	3/16	7/16
G7029/16	9/16	0.5625	1.1/4	4.5/16	1/2	3	3/16	3/16	1/2
G70219/32	19/32	0.5938	1.1/4	5.1/8	1/2	3	3/16	3/16	17/32
G7025/8	5/8	0.6250	1.1/4	5.1/8	1/2	3	3/16	3/16	9/16
G70211/16	11/16	0.6875	1.1/4	5.1/8	1/2	3	3/16	3/16	5/8
G7023/4	3/4	0.7500	1.1/2	5.3/8	1/2	3	1/4	5/16	11/16
G70225/32	25/32	0.7813	1.1/2	5.3/8	5/8	3	1/4	5/16	23/32
G70213/16	13/16	0.8125	1.1/2	5.3/8	5/8	3	1/4	5/16	3/4
G70227/32	27/32	0.8438	1.1/2	5.3/8	3/4	3	1/4	5/16	25/32
G7027/8	7/8	0.8750	1.1/2	5.3/8	3/4	3	1/4	5/16	13/16
G7021	1"	1.0000	1.3/4	6.3/8	3/4	3	5/16	3/8	15/16
G7022	2"	2.0000	2.1/2	8.3/8	1.1/2	5	1/2	9/16	1.15/16

G703



Corps de fraise à lamer HSS, avec queue conique, type pilote amovible

Corps de fraise à lamer à queue cone Morse utilisé avec des pilotes amovibles pour réaliser un lamage à fond plat. Un pilote amovible non coupant G704 est monté dans le corps qui suit le trou existant pour guider et centrer l'opération de lamage.

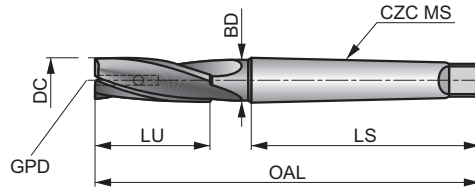

HSS	Bright	ANSI
R		

Adéquation du groupe de matériaux de la pièce, valeurs de départ pour la vitesse de coupe (m/min) et code Alpha d'avance. Les tableaux d'avances par tour se trouvent à partir de la page 274.

P1.1 ■ 20 E	P1.2 ■ 22 E	P1.3 ■ 23 E	P2.1 ■ 17 E	P2.2 ■ 15 D	P2.3 ■ 13 C	P3.1 ■ 12 D	P3.2 ■ 9 D	P3.3 ■ 8 C	P4.1 ■ 7 D	P4.2 ■ 6 C	P4.3 ■	M1.1 ■ 8 D	M1.2 ■ 6 D
M2.1 ■ 7 D	M2.2 ■ 6 D	M2.3 ■ 5 C	K1.1 ■ 17 E	K1.2 ■ 12 E	K1.3 ■ 11 E	K2.1 ■ 15 D	K2.2 ■ 12 D	K2.3 ■ 10 C	K3.1 ■ 13 D	K3.2 ■ 10 D	K4.1 ■ 12 D	K4.2 ■ 9 D	K5.1 ■ 14 D
K5.2 ■ 10 D	N1.1 ■ 30 G	N1.2 ■ 23 G	N1.3 ■ 15 G	N2.1 ■ 31 G	N2.2 ■ 28 G	N2.3 ■ 20 G	N3.1 ■ 34 C	N3.2 ■ 20 C	N3.3 ■ 10 C	N4.1 ■ 30 C	N4.2 ■ 20 C		

Product	DC (inch)	DC (inch)	LU (inch)	OAL (inch)	CZC MS	BD (inch)	LS (inch)	NOF	GPD (inch)	GPDN (inch)	GPDX (inch)
G7031/2	1/2	0.5000	1.1/4	4.5/16	1	29/64	2.9/16	3	3/16	1/4	7/16
G70311/16	11/16	0.6875	1.1/4	5.1/8	2	5/8	3.1/8	3	3/16	1/4	5/8
G7033/4	3/4	0.7500	1.1/2	5.3/8	2	21/32	3.1/8	3	1/4	5/16	11/16
G70313/16	13/16	0.8125	1.1/2	5.3/8	2	21/32	3.1/8	3	1/4	5/16	3/4
G7037/8	7/8	0.8750	1.1/2	5.3/8	2	21/32	3.1/8	3	1/4	5/16	13/16
G70315/16	15/16	0.9375	1.1/2	6.1/8	3	7/8	3.7/8	3	1/4	5/16	7/8
G7031	1"	1.0000	1.3/4	6.3/8	3	7/8	3.7/8	3	5/16	3/8	15/16
G7031.1/16	1.1/16	1.0625	1.3/4	6.3/8	3	7/8	3.7/8	3	5/16	3/8	1"
G7031.1/8	1.1/8	1.1250	1.3/4	6.3/8	3	7/8	3.7/8	3	5/16	3/8	1.1/16
G7031.3/16	1.3/16	1.1875	1.3/4	6.3/8	3	7/8	3.7/8	3	5/16	3/8	1.1/8
G7031.1/4	1.1/4	1.2500	2"	6.5/8	3	7/8	3.7/8	5	3/8	7/16	1.3/16
G7031.3/8	1.3/8	1.3750	2"	6.5/8	3	7/8	3.7/8	5	3/8	7/16	1.5/16
G7031.1/2	1.1/2	1.5000	2"	7.7/8	4	1.3/16	4.7/8	5	3/8	7/16	1.7/16
G7031.5/8	1.5/8	1.6250	2.1/4	8.1/8	4	1.3/8	4.7/8	5	7/16	1/2	1.9/16
G7032	2"	2.0000	2.1/2	8.3/8	4	1.1/2	4.7/8	5	1/2	9/16	1.5/16
G7032.1/8	2.1/8	2.1250	2.1/2	9.7/8	5	1.3/4	6.1/8	5	1/2	9/16	2.1/16

G704



Pilote amovible à utiliser avec un corps d'alesoir à lamer en HSS

Pilote amovible non coupant à utiliser avec les corps d'alesoir à lamer pour suivre le trou existant dans la pièce à usiner. Plusieurs pilotes ayant le même diamètre de montage (queue) s'adapteront au diamètre de montage du corps de l'alesoir. Veillez à ce que le diamètre de montage du pilote corresponde correctement au diamètre de montage du corps

HSS	Bright	ANSI
		

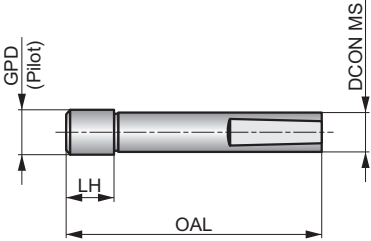

Product	GPD (inch)	DCON MS (inch)	LH (inch)	OAL (inch)
G7041/8X3/32	1/8	3/32	0.125	1.1/4
G7045/32X3/32	5/32	3/32	0.188	1.5/16
G7043/16X3/32	3/16	3/32	0.188	1.5/16
G7047/32X3/32	7/32	3/32	0.250	1.3/8
G7041/4X3/32	1/4	3/32	0.250	1.3/8
G7041/8X1/8	1/8	1/8	0.125	1.7/16
G7045/32X1/8	5/32	1/8	0.188	1.1/2
G7043/16X1/8	3/16	1/8	0.188	1.1/2
G7047/32X1/8	7/32	1/8	0.250	1.9/16
G7041/4X1/8	1/4	1/8	0.250	1.9/16
G7049/32X1/8	9/32	1/8	0.313	1.5/8
G7045/16X1/8	5/16	1/8	0.313	1.5/8
G7043/8X1/8	3/8	1/8	0.375	1.11/16
G7047/16X1/8	7/16	1/8	0.438	1.3/4
G7041/2X1/8	1/2	1/8	0.500	1.13/16
G7043/16X5/32	3/16	5/32	0.188	1.9/16
G7047/32X5/32	7/32	5/32	0.250	1.5/8
G7041/4X5/32	1/4	5/32	0.250	1.5/8
G7049/32X5/32	9/32	5/32	0.313	1.11/16
G7045/16X5/32	5/16	5/32	0.313	1.11/16
G7043/8X5/32	3/8	5/32	0.375	1.3/4
G7043/16X3/16	3/16	3/16	0.250	1.7/8
G7047/32X3/16	7/32	3/16	0.250	1.7/8
G7041/4X3/16	1/4	3/16	0.250	1.7/8
G7049/32X3/16	9/32	3/16	0.313	1.15/16
G7045/16X3/16	5/16	3/16	0.313	1.15/16
G70411/32X3/16	11/32	3/16	0.375	2"
G7043/8X3/16	3/8	3/16	0.375	2"
G70413/32X3/16	13/32	3/16	0.438	2.1/16
G7047/16X3/16	7/16	3/16	0.438	2.1/16
G70415/32X3/16	15/32	3/16	0.500	2.1/8
G7041/2X3/16	1/2	3/16	0.500	2.1/8
G7049/16X3/16	9/16	3/16	0.563	2.3/16
G7045/8X3/16	5/8	3/16	0.563	2.3/16
G70413/16X3/16	13/16	3/16	0.813	2.7/16
G7047/8X3/16	7/8	3/16	0.875	2.1/2
G7041/4X1/4	1/4	1/4	0.250	1.11/16
G7049/32X1/4	9/32	1/4	0.313	1.3/4
G7045/16X1/4	5/16	1/4	0.313	1.3/4

Product	GPD (inch)	DCON MS (inch)	LH (inch)	OAL (inch)
G7043/8X1/4	3/8	1/4	0.375	1.13/16
G7047/16X1/4	7/16	1/4	0.438	1.7/8
G7041/2X1/4	1/2	1/4	0.500	1.15/16
G70417/32X1/4	17/32	1/4	0.563	2"
G7049/16X1/4	9/16	1/4	0.563	2"
G7045/8X1/4	5/8	1/4	0.625	2.1/16
G70411/16X1/4	11/16	1/4	0.688	2.1/8
G7043/4X1/4	3/4	1/4	0.750	2.3/16
G70413/16X1/4	13/16	1/4	0.875	2.5/16
G7041X1/4	1"	1/4	1.000	2.7/16
G7043/8X5/16	3/8	5/16	0.375	2"
G7047/16X5/16	7/16	5/16	0.438	2.1/16
G7041/2X5/16	1/2	5/16	0.500	2.1/8
G7049/16X5/16	9/16	5/16	0.563	2.3/16
G7045/8X5/16	5/8	5/16	0.625	2.1/4
G70411/16X5/16	11/16	5/16	0.688	2.5/16
G7043/4X5/16	3/4	5/16	0.750	2.3/8
G70413/16X5/16	13/16	5/16	0.875	2.1/2
G70415/16X5/16	15/16	5/16	1.000	2.5/8
G7041X5/16	1"	5/16	1.000	2.5/8
G7047/16X3/8	7/16	3/8	0.438	2.5/16
G7041/2X3/8	1/2	3/8	0.500	2.3/8
G7049/16X3/8	9/16	3/8	0.563	2.7/16
G7045/8X3/8	5/8	3/8	0.625	2.1/2
G70411/16X3/8	11/16	3/8	0.688	2.9/16
G7043/4X3/8	3/4	3/8	0.750	2.5/8
G70413/16X3/8	13/16	3/8	0.875	2.3/4
G7047/8X3/8	7/8	3/8	0.875	2.3/4
G70415/16X3/8	15/16	3/8	1.000	2.5/8
G7049/16X7/16	9/16	7/16	0.625	2.7/8
G70411/16X7/16	11/16	7/16	0.750	3"
G7043/4X7/16	3/4	7/16	0.750	3"
G70413/16X7/16	13/16	7/16	0.875	3.1/8
G7047/8X7/16	7/8	7/16	0.875	3.1/8
G70415/16X7/16	15/16	7/16	1.000	3.1/4
G7041X7/16	1"	7/16	1.000	3.1/4
G7049/16X1/2	9/16	1/2	0.625	3.1/8
G7041X1/2	1"	1/2	1.000	3.1/2
G7041.1/2X1/2	1.1/2	1/2	1.500	4"

G705



Corps de fraise à lamer HSS, série longue pour l'aviation, type pilote amovible

Corps de fraise à lamer à queue cylindrique série longue pour l'aéronautique, utilisé avec des pilotes amovibles pour réaliser un lamage à fond plat. Un pilote amovible non coupant G704 est monté dans le corps qui suit le trou existant pour guider et centrer l'opération de lamage.

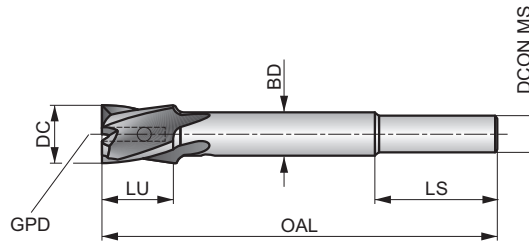

HSS	Bright	ANSI
R		

Adéquation du groupe de matériaux de la pièce, valeurs de départ pour la vitesse de coupe (m/min) et code Alpha d'avance. Les tableaux d'avances par tour se trouvent à partir de la page 274.

P1.1 ■ 20 E	P1.2 ■ 22 E	P1.3 ■ 23 E	P2.1 ■ 17 E	P2.2 ■ 15 D	P2.3 ▧ 13 C	P3.1 ■ 12 D	P3.2 ▧ 9 D	P3.3 ▧ 8 C	P4.1 ▧ 7 D	P4.2 ▧ 6 C	M1.1 ▧ 8 D	M1.2 ▧ 6 D	M2.1 ▧ 7 D
M2.2 ▧ 6 D	M2.3 ▧ 5 C	K1.1 ■ 17 E	K1.2 ▧ 12 E	K1.3 ▧ 11 E	K2.1 ■ 15 D	K2.2 ▧ 12 D	K2.3 ▧ 10 C	K3.1 ▧ 13 D	K3.2 ▧ 10 D	K4.1 ▧ 12 D	K4.2 ▧ 9 D	K5.1 ■ 14 D	K5.2 ▧ 10 D
N1.1 ▧ 30 G	N1.2 ■ 23 G	N1.3 ■ 15 G	N2.1 ▧ 31 G	N2.2 ▧ 28 G	N2.3 ▧ 20 G	N3.1 ■ 34 C	N3.2 ■ 20 C	N3.3 ▧ 10 C	N4.1 ■ 30 C	N4.2 ▧ 20 C			

Product	DC (inch)	DC (inch)	LU (inch)	OAL (inch)	DCON MS (inch)	LS (inch)	BD (inch)	NOF	GPD (inch)	GPDN (inch)	GPDX (inch)
G7051/4	1/4	0.2500	1/2	4	15/64	15/64	15/64	4	3/32	1/8	3/16
G7055/16	5/16	0.3125	1/2	4	19/64	19/64	19/64	4	3/32	1/8	1/4
G7053/8	3/8	0.3750	5/8	4	5/16	5/16	5/16	4	3/32	1/8	5/16
G7057/16	7/16	0.4375	5/8	4	3/8	3/8	3/8	4	1/8	3/16	3/8
G7051/2	1/2	0.5000	5/8	4.1/4	7/16	7/16	7/16	4	1/8	1/8	7/16
G70517/32	17/32	0.5313	5/8	4.1/4	1/2	1/2	1/2	4	1/8	1/8	1/2
G7059/16	9/16	0.5625	5/8	4.1/4	1/2	1/2	1/2	4	1/8	1/8	1/2
G70519/32	19/32	0.5938	5/8	4.1/4	1/2	9/16	9/16	4	1/8	1/8	1/2
G7055/8	5/8	0.6250	5/8	4.1/4	1/2	9/16	9/16	4	1/8	1/8	1/2
G70521/32	21/32	0.6563	5/8	5.3/8	1/2	9/16	9/16	4	3/16	3/16	5/8
G70511/16	11/16	0.6875	5/8	5.3/8	1/2	5/8	5/8	4	3/16	3/16	5/8
G7053/4	3/4	0.7500	3/4	5.3/8	1/2	11/16	11/16	4	3/16	3/16	5/8
G70525/32	25/32	0.7813	3/4	5.3/8	1/2	11/16	11/16	4	3/16	3/16	5/8
G70513/16	13/16	0.8125	3/4	5.3/8	1/2	3/4	3/4	4	3/16	3/16	5/8
G7057/8	7/8	0.8750	15/16	5.3/8	1/2	3/4	3/4	4	3/16	3/16	13/16
G70515/16	15/16	0.9375	15/16	5.3/8	1/2	3/4	3/4	4	3/16	3/16	7/8

G706



Corps de fraise à lamer HSS, série courte pour l'aviation, type pilote amovible

Corps de fraise à lamer à queue cylindrique série courte pour l'aéronautique, utilisé avec des pilotes amovibles pour réaliser un lamage à fond plat. Un pilote amovible non coupant G704 est monté dans le corps qui suit le trou existant pour guider et centrer l'opération de lamage.

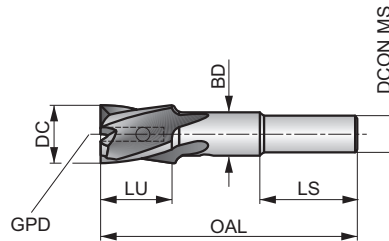

HSS	Bright	ANSI
R		

Adéquation du groupe de matériaux de la pièce, valeurs de départ pour la vitesse de coupe (m/min) et code Alpha d'avance. Les tableaux d'avances par tour se trouvent à partir de la page 274.

P1.1 ■ 20 E	P1.2 ■ 22 E	P1.3 ■ 23 E	P2.1 ■ 17 E	P2.2 ■ 15 D	P2.3 ▧ 13 C	P3.1 ■ 12 D	P3.2 ▧ 9 D	P3.3 ▧ 8 C	P4.1 ▧ 7 D	P4.2 ▧ 6 C	M1.1 ▧ 8 D	M1.2 ▧ 6 D	M2.1 ▧ 7 D
M2.2 ▧ 6 D	M2.3 ▧ 5 C	K1.1 ■ 17 E	K1.2 ▧ 12 E	K1.3 ▧ 11 E	K2.1 ■ 15 D	K2.2 ▧ 12 D	K2.3 ▧ 10 C	K3.1 ▧ 13 D	K3.2 ▧ 10 D	K4.1 ▧ 12 D	K4.2 ▧ 9 D	K5.1 ■ 14 D	K5.2 ▧ 10 D
N1.1 ▧ 30 G	N1.2 ■ 23 G	N1.3 ■ 15 G	N2.1 ▧ 31 G	N2.2 ▧ 28 G	N2.3 ▧ 20 G	N3.1 ■ 34 C	N3.2 ■ 20 C	N3.3 ▧ 10 C	N4.1 ■ 30 C	N4.2 ▧ 20 C			

Product	DC (inch)	DC (inch)	LU (inch)	OAL (inch)	DCON MS (inch)	LS (inch)	BD (inch)	NOF	GPD (inch)	GPDN (inch)	GPDx (inch)
G7061/4	1/4	0.2500	1/2	2.3/8	1/4	1.1/8	15/64	4	3/32	1/8	3/16
G7065/16	5/16	0.3125	1/2	2.3/8	1/4	7/8	17/64	4	3/32	1/8	1/4
G70611/32	11/32	0.3438	1/2	2.3/8	1/4	7/8	19/64	4	3/32	1/8	9/32
G7063/8	3/8	0.3750	1/2	2.3/8	1/4	7/8	5/16	4	3/32	3/16	5/16
G70613/32	13/32	0.4063	1/2	2.13/16	1/4	7/8	5/16	4	1/8	3/16	11/32
G7067/16	7/16	0.4375	1/2	2.13/16	1/4	7/8	5/16	4	1/8	3/16	3/8
G70615/32	15/32	0.4688	1/2	2.13/16	1/4	7/8	5/16	4	1/8	1/4	13/32
G7061/2	1/2	0.5000	1/2	2.13/16	1/4	7/8	3/8	4	1/8	1/4	7/16
G70617/32	17/32	0.5313	1/2	2.13/16	1/4	7/8	3/8	4	1/8	1/4	15/32
G7069/16	9/16	0.5625	1/2	2.13/16	1/4	7/8	3/8	4	1/8	1/4	1/2
G70611/16	11/16	0.6875	1/2	2.13/16	1/4	7/8	1/2	4	1/8	1/4	5/8
G7063/4	3/4	0.7500	1/2	2.13/16	1/4	7/8	1/2	4	3/16	5/16	11/16
G70613/16	13/16	0.8125	1/2	2.13/16	1/4	7/8	1/2	4	3/16	5/16	3/4
G7067/8	7/8	0.8750	1/2	2.13/16	1/4	7/8	1/2	4	3/16	5/16	13/16
G7061	1"	1.0000	1/2	2.13/16	1/4	7/8	1/2	4	3/16	3/8	15/16

A400



Foret étagé en HSS, finition avec traitement vapeur

Foret polyvalent conçu pour percer des trous de passage chanfreinés pour des vis à têtes fraisées métriques standard. Pointe à 118° avec chanfrein à 90°. Convient à la fois aux machines CNC et conventionnelles. La finition avec traitement vapeur retient le fluide de coupe et empêche le collage des copeaux sur l'outil. Convient pour percer de nombreux matériaux.

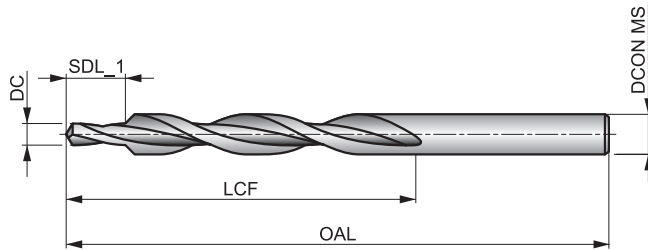

HSS	DIN 8374	4xD
90°	ST	
λ 20-35°	R	118°

Adéquation du groupe de matériaux de la pièce, valeurs de départ pour la vitesse de coupe (m/min) et code Alpha d'avance. Les tableaux d'avances par tour se trouvent à partir de la page 274.

P1.1 ■ 29 G	P1.2 ■ 33 G	P1.3 ■ 34 G	P2.1 ■ 25 G	P2.2 ■ 22 E	P2.3 ▣ 19 C	P3.1 ■ 15 E	P3.2 ■ 12 E	P3.3 ▣ 10 C	P4.1 ■ 9 E	P4.2 ▣ 7 C	P4.3 ▣ 6 C	M1.1 ▣ 22 E	M1.2 ▣ 19 E
M2.1 ▣ 20 E	M2.2 ▣ 16 E	M3.1 ▣ 10 G	M3.2 ▣ 9 G	M3.3 ▣ 8 G	M4.1 ▣ 12 C	K1.1 ■ 30 G	K1.2 ■ 22 E	K1.3 ■ 17 E	K2.1 ▣ 23 E	K2.2 ▣ 19 E	K2.3 ▣ 15 C	K3.1 ▣ 21 E	K3.2 ▣ 16 E
K3.3 ▣ 13 C	K4.1 ▣ 19 E	K4.2 ▣ 14 E	K4.3 ▣ 11 C	K4.4 ▣ 9 C	K4.5 ▣ 8 C	K5.1 ▣ 22 E	K5.2 ▣ 16 E	K5.3 ▣ 13 C	N1.1 ▣ 45 E	N1.2 ▣ 34 E	N1.3 ▣ 23 E	N2.1 ▣ 49 E	N2.2 ▣ 44 E
N2.3 ▣ 32 E	N3.1 ▣ 68 E	N3.2 ▣ 40 E	N3.3 ▣ 20 E	N4.1 ▣ 30 I	S1.1 ▣ 23 E	S1.2 ▣ 14 C	S1.3 ▣ 8 A	S2.1 ▣ 8 C	S2.2 ▣ 6 A	S3.1 ▣ 6 C	S3.2 ▣ 4 A	S4.1 ▣ 5 C	S4.2 ▣ 3 A

Product	TDZ	DC	DC	LCF	OAL	SDL_1	DCON MS
		(mm)	(inch)				
A400M3	M3	3.20	0.1260	57.0	93.0	9.00	6.00
A400M4	M4	4.30	0.1693	75.0	117.0	11.00	8.00
A400M5	M5	5.30	0.2087	87.0	133.0	13.00	10.00
A400M6	M6	6.40	0.2520	94.0	142.0	15.00	11.50
A400M8	M8	8.40	0.3307	114.0	169.0	19.00	15.00

A402

DORMER



Foret étagé en HSS, finition avec traitement vapeur

Foret polyvalent recommandé pour percer des trous de passage lamés pour les vis CHC métriques standard. Pointe à 118° avec épaulement à 180°. La finition avec traitement vapeur retient le fluide de coupe et empêche le collage des copeaux sur l'outil. Convient pour percer de nombreux matériaux.

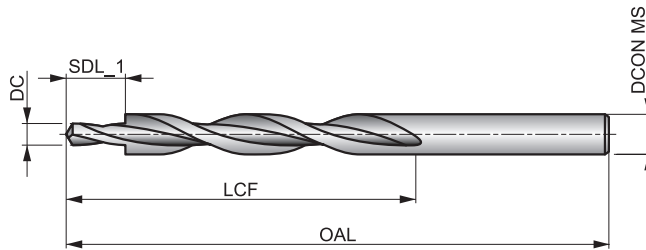

HSS	DIN 8376	4xD
180°	ST	
λ 20-35°	R	118°

Adéquation du groupe de matériaux de la pièce, valeurs de départ pour la vitesse de coupe (m/min) et code Alpha d'avance. Les tableaux d'avances par tour se trouvent à partir de la page 274.

P1.1 ■ 29 G	P1.2 ■ 33 G	P1.3 ■ 34 G	P2.1 ■ 25 G	P2.2 ■ 22 E	P2.3 ▣ 19 C	P3.1 ■ 15 E	P3.2 ■ 12 E	P3.3 ▣ 10 C	P4.1 ■ 9 E	P4.2 ▣ 7 C	P4.3 ▣ 6 C	M1.1 ▣ 22 E	M1.2 ▣ 19 E
M2.1 ▣ 20 E	M2.2 ▣ 16 E	M3.1 ▣ 10 G	M3.2 ▣ 9 G	M3.3 ▣ 8 G	M4.1 ▣ 12 C	K1.1 ■ 30 G	K1.2 ■ 22 E	K1.3 ■ 17 E	K2.1 ▣ 23 E	K2.2 ▣ 19 E	K2.3 ▣ 15 C	K3.1 ▣ 21 E	K3.2 ▣ 16 E
K3.3 ▣ 13 C	K4.1 ▣ 19 E	K4.2 ▣ 14 E	K4.3 ▣ 11 C	K4.4 ▣ 9 C	K4.5 ▣ 8 C	K5.1 ▣ 22 E	K5.2 ▣ 16 E	K5.3 ▣ 13 C	N1.1 ▣ 45 E	N1.2 ▣ 34 E	N1.3 ▣ 23 E	N2.1 ▣ 49 E	N2.2 ▣ 44 E
N2.3 ▣ 32 E	N3.1 ▣ 68 E	N3.2 ▣ 40 E	N3.3 ▣ 20 E	N4.1 ▣ 30 I	S1.1 ▣ 23 E	S1.2 ▣ 14 C	S1.3 ▣ 8 A	S2.1 ▣ 8 C	S2.2 ▣ 6 A	S3.1 ▣ 6 C	S3.2 ▣ 4 A	S4.1 ▣ 5 C	S4.2 ▣ 3 A

Product	TDZ	DC	DC	LCF	OAL	SDL_1	DCON MS
		(mm)	(inch)				
A402M3	M3	3.40	0.1339	57.0	93.0	9.00	6.00
A402M4	M4	4.50	0.1772	75.0	117.0	11.00	8.00
A402M5	M5	5.50	0.2165	87.0	133.0	13.00	10.00
A402M6	M6	6.60	0.2598	94.0	142.0	15.00	11.00
A402M8	M8	9.00	0.3543	114.0	169.0	19.00	15.00
A402M10	M10	11.00	0.4331	130.0	191.0	23.00	18.00

A413

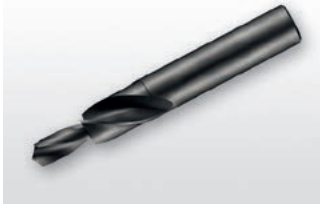

Foret étagé en HSS, finition avec traitement vapeur

Foret polyvalent recommandé pour percer des trous de passage lamés pour les vis CHC métriques standard. Pointe à 118° avec épaulement à 180°. La finition avec traitement vapeur retient le fluide de coupe et empêche le collage des copeaux sur l'outil. Convient à la fois aux machines CNC et conventionnelles. Convient pour percer de nombreux matériaux.

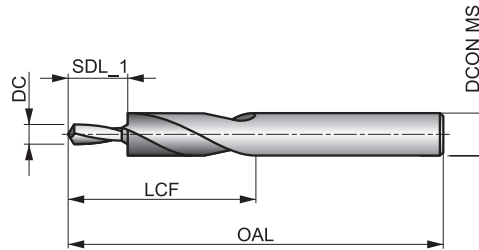

HSS	DORMER	2.5xD
180°	ST	
R	118°	

Adéquation du groupe de matériaux de la pièce, valeurs de départ pour la vitesse de coupe (m/min) et code Alpha d'avance. Les tableaux d'avances par tour se trouvent à partir de la page 274.

P1.1 ■ 29I	P1.2 ■ 33I	P1.3 ■ 34I	P2.1 ■ 25I	P2.2 ■ 22G	P2.3 ▣ 19E	P3.1 ■ 15G	P3.2 ■ 12G	P3.3 ▣ 10E	P4.1 ■ 9G	P4.2 ▣ 7E	P4.3 ▣ 6C	M1.1 ■ 22G	M1.2 ■ 19G
M2.1 ■ 20G	M2.2 ■ 16G	M3.1 ▣ 10I	M3.2 ▣ 9I	M3.3 ▣ 8I	M4.1 ▣ 12E	K1.1 ■ 30G	K1.2 ■ 22E	K1.3 ■ 17E	K2.1 ▣ 23E	K2.2 ▣ 19E	K2.3 ▣ 15E	K3.1 ▣ 21E	K3.2 ▣ 16E
K3.3 ▣ 13E	K4.1 ▣ 19E	K4.2 ▣ 14E	K4.3 ▣ 11E	K4.4 ▣ 9E	K4.5 ▣ 8E	K5.1 ▣ 22E	K5.2 ▣ 16E	K5.3 ▣ 13E	N1.1 ▣ 45G	N1.2 ▣ 34G	N1.3 ▣ 23G	N2.1 ▣ 42G	N2.2 ▣ 37G
N2.3 ▣ 27G	N3.1 ▣ 68G	N3.2 ▣ 40G	N3.3 ▣ 20G	N4.1 ▣ 30I	S1.1 ▣ 27G	S1.2 ▣ 16E	S1.3 ▣ 8C	S2.1 ▣ 11G	S2.2 ▣ 6C	S3.1 ▣ 8G	S3.2 ▣ 4C	S4.1 ▣ 6G	S4.2 ▣ 3C

Product	TDZ	DC	DC	LCF	OAL	SDL_1	DCON MS
		(mm)	(inch)				
A413M3	M3	3.40	0.1339	28.0	66.0	9.00	6.00
A413M4	M4	4.50	0.1772	37.0	79.0	11.00	8.00
A413M5	M5	5.50	0.2165	43.0	89.0	13.00	10.00
A413M6	M6	6.60	0.2598	47.0	95.0	15.00	11.00
A413M8	M8	9.00	0.3543	56.0	111.0	19.00	15.00
A413M10	M10	11.00	0.4331	62.0	123.0	23.00	18.00

A412



Foret étagé en HSS, finition avec traitement vapeur

Foret conçu pour percer des trous de passage chanfreinés pour des vis à têtes fraisées métriques standard. Un angle de pointe de 118° sur le pilote de forage avec un chanfrein de 90°. La finition avec traitement vapeur retient le fluide de coupe et empêche le collage des copeaux sur l'outil. Convient pour percer de nombreux matériaux. Il convient aux machines CNC et conventionnelles.

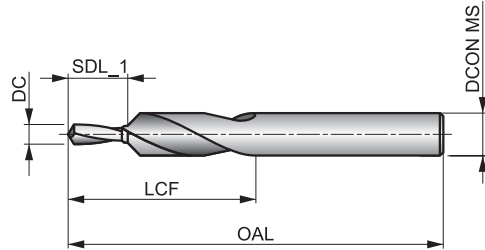

HSS		2.5xD
90°		
R		

Adéquation du groupe de matériaux de la pièce, valeurs de départ pour la vitesse de coupe (m/min) et code Alpha d'avance. Les tableaux d'avances par tour se trouvent à partir de la page 274.

P1.1 ■ 29 I	P1.2 ■ 33 I	P1.3 ■ 34 I	P2.1 ■ 25 I	P2.2 ■ 22 G	P2.3 ■ 19 E	P3.1 ■ 15 G	P3.2 ■ 12 G	P3.3 ■ 10 E	P4.1 ■ 9 G	P4.2 ■ 7 E	P4.3 ■ 6 C	M1.1 ■ 22 G	M1.2 ■ 19 G
M2.1 ■ 20 G	M2.2 ■ 16 G	M3.1 ■ 10 I	M3.2 ■ 9 I	M3.3 ■ 8 I	M4.1 ■ 12 E	K1.1 ■ 30 G	K1.2 ■ 22 E	K1.3 ■ 17 E	K2.1 ■ 23 E	K2.2 ■ 19 E	K2.3 ■ 15 E	K3.1 ■ 21 E	K3.2 ■ 16 E
K3.3 ■ 13 E	K4.1 ■ 19 E	K4.2 ■ 14 E	K4.3 ■ 11 E	K4.4 ■ 9 E	K4.5 ■ 8 E	K5.1 ■ 22 E	K5.2 ■ 16 E	K5.3 ■ 13 E	N1.1 ■ 45 G	N1.2 ■ 34 G	N1.3 ■ 23 G	N2.1 ■ 42 G	N2.2 ■ 37 G
N2.3 ■ 27 G	N3.1 ■ 68 G	N3.2 ■ 40 G	N3.3 ■ 20 G	N4.1 ■ 30 I	S1.1 ■ 27 G	S1.2 ■ 16 E	S1.3 ■ 8 C	S2.1 ■ 11 G	S2.2 ■ 6 C	S3.1 ■ 8 G	S3.2 ■ 4 C	S4.1 ■ 6 G	S4.2 ■ 3 C

Product	TDZ	DC	DC	LCF	OAL	SDL_1	DCON MS
		(mm)	(inch)				
A412M3	M3	3.40	0.1339	31.0	70.0	9.00	6.60
A412M4	M4	4.50	0.1772	40.0	84.0	11.00	9.00
A412M5	M5	5.50	0.2165	47.0	95.0	13.00	11.00
A412M6	M6	6.60	0.2598	51.0	102.0	15.00	13.00
A412M8	M8	9.00	0.3543	62.0	123.0	19.00	17.20
A412M10	M10	11.00	0.4331	70.0	141.0	23.00	21.50

Code de matériau du corps (BMC)	HSS	HSS	HSS-E	HSS-E	HSS	HSS	HSS	HSS-E	HM	HSS
Groupe standard de base (BSG)	DIN 333A	DIN 333A	DIN 333A	DIN 333A	DIN 333R	DORMER	BS 328	DORMER	DIN 333A	
Rapport longueur utile diamètre (ULDR)	1xD	1xD	1xD	1xD	1xD	1xD	1xD	1xD	1xD	1xD
Angle d'application	60°	60°	60°	60°	R	60°	60°	60°	60°	60°
Revêtement	Bright	TiN	Bright	TiAlN	Bright	Bright	Bright	Bright	Bright	Bright
Queue										
Sens (direction de coupe)	R	R	R	R	R	R	R	R	R	R

Code de famille de produits	A200	A205	A206	A266	A210	A201	A225	A242	R200	A296
Plage de diamètres de coupe PSF	0.50 - 12.50	1.00 - 5.00	1.00 - 5.00	1.00 - 5.00	0.50 - 8.00	0.63 - 6.00	3/64 - 5/16	1.00 - 5.00	1.00 - 5.00	Set

P	P1	■	■	■	■	■	■	■	■	
	P2	■	■	■	■	■	■	■	■	
	P3	■	■	■	■	■	■	■	■	
	P4	■	■	■	■	■	■	■	■	■
M	M1	■	■	■	■	■	■	■	■	
	M2	■	■	■	■	■	■	■	■	
	M3	■	■	■	■	■	■	■	■	
	M4	■	■	■	■	■	■	■	■	
K	K1	■	■	■	■	■	■	■	■	■
	K2	■	■	■	■	■	■	■	■	■
	K3	■	■	■	■	■	■	■	■	■
	K4	■	■	■	■	■	■	■	■	■
	K5	■	■	■	■	■	■	■	■	■
N	N1	■	■	■	■	■	■	■	■	■
	N2	■	■	■	■	■	■	■	■	■
	N3	■	■	■	■	■	■	■	■	■
	N4	■	■	■	■	■	■	■	■	■
	N5	■	■	■	■	■	■	■	■	■
S	S1	■	■	■	■	■	■	■	■	
	S2	■	■	■	■	■	■	■	■	
	S3	■	■	■	■	■	■	■	■	
	S4	■	■	■	■	■	■	■	■	
H	H1									
	H2									
	H3									
	H4									

A200

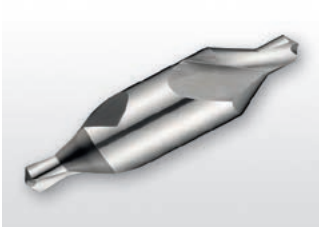

Foret à centrer en HSS avec pointe à 118° et chanfrein à 60°, finition brillante

Foret à centrer avec deux extrémités de perçage qui permettent d'augmenter la productivité par outil. Convient à de nombreux matériaux.

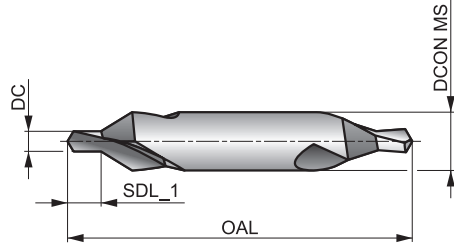

HSS	DIN 333A	1xD
60°	Bright	
R	118°	

Adéquation du groupe de matériaux de la pièce, valeurs de départ pour la vitesse de coupe (m/min) et code Alpha d'avance. Les tableaux d'avances par tour se trouvent à partir de la page 274.

P1.1 ■ 33 I	P1.2 ■ 37 I	P1.3 ■ 38 I	P2.1 ■ 28 I	P2.2 ■ 25 G	P2.3 ■ 22 E	P3.1 ■ 19 F	P3.2 ■ 15 F	P3.3 ■ 13 E	P4.1 ■ 11 F	P4.2 ■ 10 E	P4.3 ■ 8 D	M1.1 ■ 21 E	M1.2 ■ 17 E
M2.1 ■ 18 E	M2.2 ■ 15 E	M3.1 ■ 9 G	M3.2 ■ 8 G	M3.3 ■ 7 G	M4.1 ■ 10 C	K1.1 ■ 30 I	K1.2 ■ 22 F	K1.3 ■ 17 F	K2.1 ■ 25 E	K2.2 ■ 20 E	K2.3 ■ 16 E	K3.1 ■ 22 E	K3.2 ■ 17 E
K3.3 ■ 13 E	K4.1 ■ 20 E	K4.2 ■ 15 E	K4.3 ■ 11 E	K4.4 ■ 10 E	K4.5 ■ 8 E	K5.1 ■ 23 E	K5.2 ■ 17 E	K5.3 ■ 13 E	N1.1 ■ 33 J	N1.2 ■ 25 J	N1.3 ■ 17 I	N2.1 ■ 42 H	N2.2 ■ 37 H
N2.3 ■ 27 H	N3.1 ■ 56 H	N3.2 ■ 33 I	N3.3 ■ 17 G	N4.1 ■ 30 J	N4.2 ■ 28 H	N4.3 ■ 14 F	S1.1 ■ 24 F	S1.2 ■ 13 D	S1.3 ■ 7 B	S2.1 ■ 7 E	S2.2 ■ 6 A	S3.1 ■ 5 E	S3.2 ■ 4 A
S4.1 ■ 4 E	S4.2 ■ 3 A												

Les produits de cette série sont également disponibles en coffret. Voir A296.

Product	DC	DC	SDL_1	OAL	DCON MS
	(mm)	(inch)			
A200.5X3.15 ¹⁾	0.50	0.0197	0.9 - 0.6	25.0	3.15
A200.8X3.15 ¹⁾	0.80	0.0315	1.3 - 1.0	25.0	3.15
A2001.0X3.15	1.00	0.0394	1.7 - 1.3	31.0	3.15
A2001.25X3.15	1.25	0.0492	2.0 - 1.6	31.0	3.15
A2001.6X4.0	1.60	0.0630	2.6 - 2.0	35.0	4.00
A2002.0X5.0	2.00	0.0787	3.1 - 2.5	40.0	5.00
A2002.5X6.3	2.50	0.0984	3.8 - 3.1	45.0	6.30
A2003.15X8.0	3.15	0.1240	4.6 - 3.9	50.0	8.00
A2004.0X10.0	4.00	0.1575	5.9 - 5.0	55.0	10.00
A2005.0X12.5	5.00	0.1969	7.2 - 6.3	63.0	12.50
A2006.3X16.0	6.30	0.2480	8.9 - 8.0	71.0	16.00
A2008.0X20.0	8.00	0.3150	11.1 - 10.1	80.0	20.00
A20010.0X25.0	10.00	0.3937	13.8 - 12.8	100.0	25.00
A20012.5X31.5	12.50	0.4921	17.5 - 16.5	125.0	31.50

¹⁾ Une seule pointe.

A205

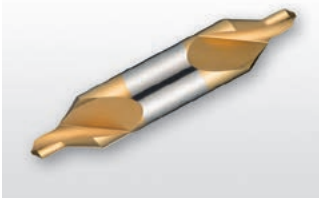

Foret à centrer en HSS avec pointe à 118° et chanfrein à 60°, revêtement TiN

Foret à centrer avec deux extrémités de perçage qui permettent d'augmenter la productivité par outil. Le revêtement TiN améliore les performances et prolonge la durée de vie de l'outil. Convient pour le perçage de nombreux matériaux.

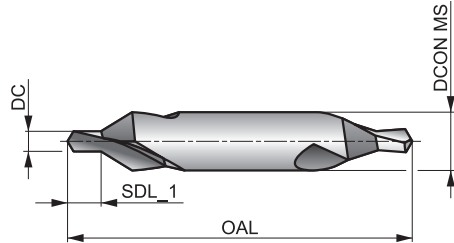

HSS	DIN 333A	1xD
60°	TiN	
R	118°	

Adéquation du groupe de matériaux de la pièce, valeurs de départ pour la vitesse de coupe (m/min) et code Alpha d'avance. Les tableaux d'avances par tour se trouvent à partir de la page 274.

P1.1 ■ 40 I	P1.2 ■ 45 I	P1.3 ■ 46 I	P2.1 ■ 34 I	P2.2 ■ 30 G	P2.3 ■ 27 E	P3.1 ■ 24 F	P3.2 ■ 19 F	P3.3 ■ 16 E	P4.1 ■ 14 F	P4.2 ■ 12 E	P4.3 ■ 10 D	M1.1 ■ 25 E	M1.2 ■ 21 E
M2.1 ■ 22 E	M2.2 ■ 18 E	M3.1 ■ 12 G	M3.2 ■ 10 G	M3.3 ■ 9 G	M4.1 ■ 12 C	K1.1 ■ 36 I	K1.2 ■ 27 F	K1.3 ■ 20 F	K2.1 ■ 30 E	K2.2 ■ 24 E	K2.3 ■ 19 E	K3.1 ■ 26 E	K3.2 ■ 20 E
K3.3 ■ 16 E	K4.1 ■ 24 E	K4.2 ■ 18 E	K4.3 ■ 13 E	K4.4 ■ 11 E	K4.5 ■ 10 E	K5.1 ■ 27 E	K5.2 ■ 21 E	K5.3 ■ 16 E	N1.1 ■ 40 J	N1.2 ■ 30 J	N1.3 ■ 20 I	N2.1 ■ 49 H	N2.2 ■ 44 H
N2.3 ■ 32 H	N3.1 ■ 68 H	N3.2 ■ 40 I	N3.3 ■ 20 G	N4.1 ■ 36 J	N4.2 ■ 34 H	N4.3 ■ 17 F	S1.1 ■ 29 F	S1.2 ■ 16 D	S1.3 ■ 8 B	S2.1 ■ 8 E	S2.2 ■ 7 A	S3.1 ■ 6 E	S3.2 ■ 5 A
S4.1 ■ 5 E	S4.2 ■ 4 A												

Product	DC	DC	SDL_1	OAL	DCON MS
	(mm)	(inch)			
A2051.0X3.15	1.00	0.0394	1.7 - 1.3	31.0	3.15
A2051.25X3.15	1.25	0.0492	2.0 - 1.6	31.0	3.15
A2051.6X4.0	1.60	0.0630	2.6 - 2.0	35.0	4.00
A2052.0X5.0	2.00	0.0787	3.1 - 2.5	40.0	5.00
A2052.5X6.3	2.50	0.0984	3.8 - 3.1	45.0	6.30
A2053.15X8.0	3.15	0.1240	4.6 - 3.9	50.0	8.00
A2054.0X10.0	4.00	0.1575	5.9 - 5.0	55.0	10.00
A2055.0X12.5	5.00	0.1969	7.2 - 6.3	63.0	12.50

A206

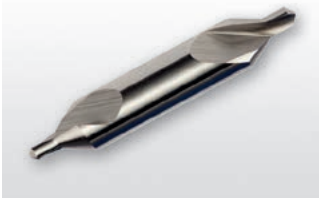

Foret à centrer en HSS-E avec pointe à 118° et chanfrein à 60°, finition brillante

Foret à centrer avec deux extrémités de perçage qui permettent d'augmenter la productivité par outil. Convient pour le perçage de nombreux matériaux.

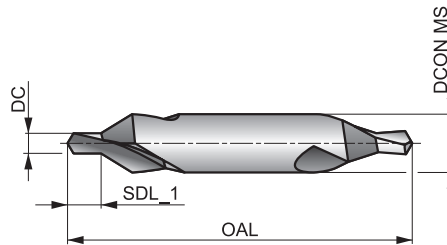

HSS-E	DIN 333A	1xD
60°	Bright	
R	118°	

Adéquation du groupe de matériaux de la pièce, valeurs de départ pour la vitesse de coupe (m/min) et code Alpha d'avance. Les tableaux d'avances par tour se trouvent à partir de la page 274.

P1.1 ■ 40 I	P1.2 ■ 45 I	P1.3 ■ 46 I	P2.1 ■ 34 I	P2.2 ■ 30 G	P2.3 ▣ 27 E	P3.1 ■ 24 F	P3.2 ■ 19 F	P3.3 ▣ 16 E	P4.1 ■ 14 F	P4.2 ▣ 12 E	P4.3 ▣ 10 D	M1.1 ▣ 25 E	M1.2 ▣ 21 E
M2.1 ▣ 22 E	M2.2 ▣ 18 E	M3.1 ▣ 12 G	M3.2 ▣ 10 G	M3.3 ▣ 9 G	M4.1 ▣ 12 C	K1.1 ■ 36 I	K1.2 ■ 27 F	K1.3 ■ 20 F	K2.1 ▣ 30 E	K2.2 ▣ 24 E	K2.3 ▣ 19 E	K3.1 ▣ 26 E	K3.2 ▣ 20 E
K3.3 ▣ 16 E	K4.1 ▣ 24 E	K4.2 ▣ 18 E	K4.3 ▣ 13 E	K4.4 ▣ 11 E	K4.5 ▣ 10 E	K5.1 ▣ 27 E	K5.2 ▣ 21 E	K5.3 ▣ 16 E	N1.1 ▣ 40 J	N1.2 ▣ 30 J	N1.3 ▣ 20 I	N2.1 ▣ 49 H	N2.2 ▣ 44 H
N2.3 ▣ 32 H	N3.1 ▣ 68 H	N3.2 ▣ 40 I	N3.3 ▣ 20 G	N4.1 ▣ 36 J	N4.2 ▣ 34 H	N4.3 ▣ 17 F	S1.1 ▣ 29 F	S1.2 ▣ 16 D	S1.3 ▣ 8 B	S2.1 ▣ 8 E	S2.2 ▣ 7 A	S3.1 ▣ 6 E	S3.2 ▣ 5 A
S4.1 ▣ 5 E	S4.2 ▣ 4 A												

Product	DC	DC	SDL_1	OAL	DCON MS
	(mm)	(inch)			
A2061.0X3.15	1.00	0.0394	1.7 - 1.3	31.0	3.15
A2061.25X3.15	1.25	0.0492	2.0 - 1.6	31.0	3.15
A2061.6X4.0	1.60	0.0630	2.6 - 2.0	35.0	4.00
A2062.0X5.0	2.00	0.0787	3.1 - 2.5	40.0	5.00
A2062.5X6.3	2.50	0.0984	3.8 - 3.1	45.0	6.30
A2063.15X8.0	3.15	0.1240	4.6 - 3.9	50.0	8.00
A2064.0X10.0	4.00	0.1575	5.9 - 5.0	55.0	10.00
A2065.0X12.5	5.00	0.1969	7.2 - 6.3	63.0	12.50

A266



Foret à centrer en HSS-E avec pointe à 118° et chanfrein à 60°, revêtement TiAlN

Foret à centrer avec deux extrémités de perçage qui permettent d'augmenter la productivité par outil. Le revêtement TiAlN améliore les performances et prolonge la durée de vie de l'outil. Convient pour le perçage de nombreux matériaux.

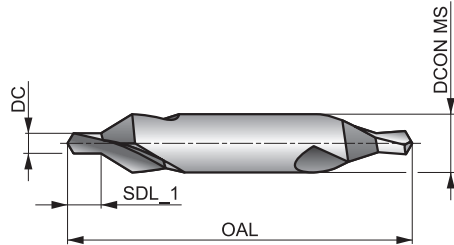

HSS-E	DIN 333A	1xD
60°	TiAlN	
R	118°	

Adéquation du groupe de matériaux de la pièce, valeurs de départ pour la vitesse de coupe (m/min) et code Alpha d'avance. Les tableaux d'avances par tour se trouvent à partir de la page 274.

P1.1 ■ 40 I	P1.2 ■ 45 I	P1.3 ■ 46 I	P2.1 ■ 34 I	P2.2 ■ 30 G	P2.3 ▣ 27 E	P3.1 ■ 24 F	P3.2 ■ 19 F	P3.3 ▣ 16 E	P4.1 ■ 14 F	P4.2 ▣ 12 E	P4.3 ▣ 10 D	M1.1 ▣ 25 E	M1.2 ▣ 21 E
M2.1 ▣ 22 E	M2.2 ▣ 18 E	M3.1 ▣ 12 G	M3.2 ▣ 10 G	M3.3 ▣ 9 G	M4.1 ▣ 12 C	K1.1 ■ 36 I	K1.2 ■ 27 F	K1.3 ■ 20 F	K2.1 ▣ 30 E	K2.2 ▣ 24 E	K2.3 ▣ 19 E	K3.1 ▣ 26 E	K3.2 ▣ 20 E
K3.3 ▣ 16 E	K4.1 ▣ 24 E	K4.2 ▣ 18 E	K4.3 ▣ 13 E	K4.4 ▣ 11 E	K4.5 ▣ 10 E	K5.1 ▣ 27 E	K5.2 ▣ 21 E	K5.3 ▣ 16 E	N1.1 ▣ 40 J	N1.2 ▣ 30 J	N1.3 ▣ 20 I	N2.1 ▣ 49 H	N2.2 ▣ 44 H
N2.3 ▣ 32 H	N3.1 ▣ 68 H	N3.2 ▣ 40 I	N3.3 ▣ 20 G	N4.1 ▣ 36 J	N4.2 ▣ 34 H	N4.3 ▣ 17 F	S1.1 ▣ 29 F	S1.2 ▣ 16 D	S1.3 ▣ 8 B	S2.1 ▣ 8 E	S2.2 ▣ 7 A	S3.1 ▣ 6 E	S3.2 ▣ 5 A
S4.1 ▣ 5 E	S4.2 ▣ 4 A												

Product	DC	DC	SDL_1	OAL	DCON MS
	(mm)	(inch)			
A2661.0X3.15	1.00	0.0394	1.7 - 1.3	31.0	3.15
A2661.25X3.15	1.25	0.0492	2.0 - 1.6	31.0	3.15
A2661.6X4.0	1.60	0.0630	2.6 - 2.0	35.0	4.00
A2662.0X5.0	2.00	0.0787	3.1 - 2.5	40.0	5.00
A2662.5X6.3	2.50	0.0984	3.8 - 3.1	45.0	6.30
A2663.15X8.0	3.15	0.1240	4.6 - 3.9	50.0	8.00
A2664.0X10.0	4.00	0.1575	5.9 - 5.0	55.0	10.00
A2665.0X12.5	5.00	0.1969	7.2 - 6.3	63.0	12.50

A210

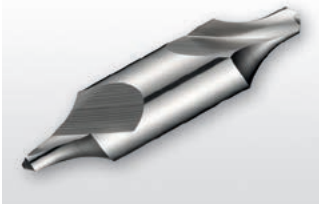

Foret à centrer en HSS avec pointe à 118° et chanfrein concave, finition brillante

Foret à centrer avec deux extrémités de perçage qui permettent d'augmenter la productivité par outil. Peut être utilisé pour usiner un certain nombre de matériaux.

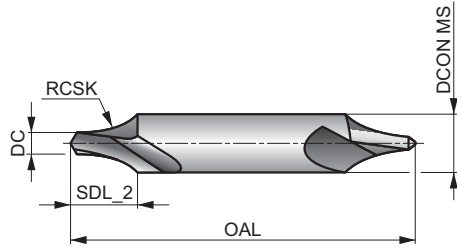

HSS	DIN 333R	1xD
R	Bright	
R	118°	

Adéquation du groupe de matériaux de la pièce, valeurs de départ pour la vitesse de coupe (m/min) et code Alpha d'avance. Les tableaux d'avances par tour se trouvent à partir de la page 274.

P1.1 ■ 33 I	P1.2 ■ 37 I	P1.3 ■ 38 I	P2.1 ■ 28 I	P2.2 ■ 25 G	P2.3 ■ 22 E	P3.1 ■ 19 F	P3.2 ■ 15 F	P3.3 ■ 13 E	P4.1 ■ 11 F	P4.2 ■ 10 E	P4.3 ■ 8 D	M1.1 ■ 21 E	M1.2 ■ 17 E
M2.1 ■ 18 E	M2.2 ■ 15 E	M3.1 ■ 9 G	M3.2 ■ 8 G	M3.3 ■ 7 G	M4.1 ■ 10 C	K1.1 ■ 30 I	K1.2 ■ 22 F	K1.3 ■ 17 F	K2.1 ■ 25 E	K2.2 ■ 20 E	K2.3 ■ 16 E	K3.1 ■ 22 E	K3.2 ■ 17 E
K3.3 ■ 13 E	K4.1 ■ 20 E	K4.2 ■ 15 E	K4.3 ■ 11 E	K4.4 ■ 10 E	K4.5 ■ 8 E	K5.1 ■ 23 E	K5.2 ■ 17 E	K5.3 ■ 13 E	N1.1 ■ 33 J	N1.2 ■ 25 J	N1.3 ■ 17 I	N2.1 ■ 42 H	N2.2 ■ 37 H
N2.3 ■ 27 H	N3.1 ■ 56 H	N3.2 ■ 33 I	N3.3 ■ 17 G	N4.1 ■ 30 J	N4.2 ■ 28 H	N4.3 ■ 14 F	S1.1 ■ 24 F	S1.2 ■ 13 D	S1.3 ■ 7 B	S2.1 ■ 7 E	S2.2 ■ 6 A	S3.1 ■ 5 E	S3.2 ■ 4 A
S4.1 ■ 4 E	S4.2 ■ 3 A												

Product	DC	DC	SDL_2	OAL	RCSR	DCON MS
	(mm)	(inch)	(mm)	(mm)	(mm)	(mm)
A210.5X3.15 ¹⁾	0.50	0.0197	2.6 - 2.3	25.0	2.50 - 2.00	3.15
A210.8X3.15 ¹⁾	0.80	0.0315	2.9 - 2.6	25.0	3.15 - 2.50	3.15
A2101.0X3.15	1.00	0.0394	3.3 - 3.0	31.0	3.65 - 2.90	3.15
A2101.25X3.15	1.25	0.0492	3.6 - 3.3	31.0	3.95 - 3.15	3.15
A2101.6X4.0	1.60	0.0630	4.7 - 4.2	35.0	5.00 - 4.00	4.00
A2102.0X5.0	2.00	0.0787	5.4 - 5.0	40.0	6.25 - 5.00	5.00
A2102.5X6.3	2.50	0.0984	6.8 - 6.3	45.0	7.88 - 6.30	6.30
A2103.15X8.0	3.15	0.1240	8.5 - 8.0	50.0	10.00 - 8.00	8.00
A2104.0X10.0	4.00	0.1575	10.6 - 10.0	55.0	12.50 - 10.00	10.00
A2105.0X12.5	5.00	0.1969	13.1 - 12.5	63.0	15.63 - 12.50	12.50
A2106.3X16.0	6.30	0.2480	16.6 - 16.0	71.0	20.00 - 16.00	16.00
A2108.0X20.0	8.00	0.3150	20.7 - 20.0	80.0	25.00 - 20.00	20.00

¹⁾ Une seule pointe.

A201

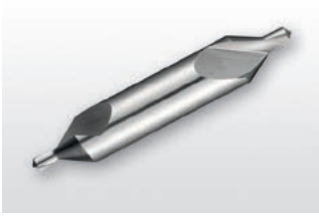

Foret à centrer en HSS avec pointe à 122° et chanfrein à 60°, finition brillante

Foret à centrer avec deux extrémités de perçage qui permettent d'augmenter la productivité par outil. Convient pour le perçage de nombreux matériaux.

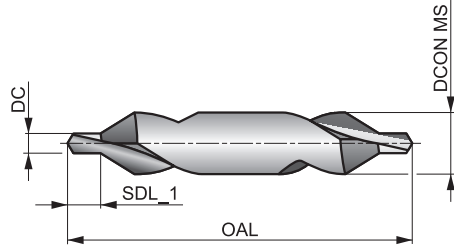

HSS		1xD
60°	Bright	
R	122°	

Adéquation du groupe de matériaux de la pièce, valeurs de départ pour la vitesse de coupe (m/min) et code Alpha d'avance. Les tableaux d'avances par tour se trouvent à partir de la page 274.

P1.1 ■ 33 I	P1.2 ■ 37 I	P1.3 ■ 38 I	P2.1 ■ 28 I	P2.2 ■ 25 G	P2.3 ■ 22 E	P3.1 ■ 19 F	P3.2 ■ 15 F	P3.3 ■ 13 E	P4.1 ■ 11 F	P4.2 ■ 10 E	P4.3 ■ 8 D	M1.1 ■ 21 E	M1.2 ■ 17 E
M2.1 ■ 18 E	M2.2 ■ 15 E	M3.1 ■ 9 G	M3.2 ■ 8 G	M3.3 ■ 7 G	M4.1 ■ 10 C	K1.1 ■ 30 I	K1.2 ■ 22 F	K1.3 ■ 17 F	K2.1 ■ 25 E	K2.2 ■ 20 E	K2.3 ■ 16 E	K3.1 ■ 22 E	K3.2 ■ 17 E
K3.3 ■ 13 E	K4.1 ■ 20 E	K4.2 ■ 15 E	K4.3 ■ 11 E	K4.4 ■ 10 E	K4.5 ■ 8 E	K5.1 ■ 23 E	K5.2 ■ 17 E	K5.3 ■ 13 E	N1.1 ■ 33 J	N1.2 ■ 25 J	N1.3 ■ 17 I	N2.1 ■ 42 H	N2.2 ■ 37 H
N2.3 ■ 27 H	N3.1 ■ 56 H	N3.2 ■ 33 I	N3.3 ■ 17 G	N4.1 ■ 30 J	N4.2 ■ 28 H	N4.3 ■ 14 F	S1.1 ■ 24 F	S1.2 ■ 13 D	S1.3 ■ 7 B	S2.1 ■ 7 E	S2.2 ■ 6 A	S3.1 ■ 5 E	S3.2 ■ 4 A
S4.1 ■ 4 E	S4.2 ■ 3 A												

Product	DC	DC	SDL_1	OAL	DCON MS
	(mm)	(inch)			
A201.63X3.15 ¹⁾	0.63	0.0248	1.2 - 0.9	20.0	3.15
A201.75X3.5	0.75	0.0295	1.3 - 1.0	35.0	3.50
A2011.0X4.0	1.00	0.0394	2.1 - 1.5	35.0	4.00
A2011.5X5.0	1.50	0.0591	2.8 - 2.0	40.0	5.00
A2011.6X5.0	1.60	0.0630	2.4 - 2.0	40.0	5.00
A2012.0X6.0	2.00	0.0787	4.0 - 3.0	45.0	6.00
A2012.0X6.3	2.00	0.0787	2.9 - 2.5	45.0	6.30
A2012.5X8.0	2.50	0.0984	4.5 - 3.5	50.0	8.00
A2013.0X8.0	3.00	0.1181	4.4 - 3.9	50.0	8.00
A2013.0X10.0	3.00	0.1181	5.0 - 4.0	56.0	10.00
A2013.15X10.0	3.15	0.1240	4.4 - 3.9	56.0	10.00
A2014.0X12.0	4.00	0.1575	6.2 - 5.0	66.0	12.00
A2015.0X14.0	5.00	0.1969	7.7 - 6.5	78.0	14.00
A2016.0X18.0	6.00	0.2362	9.2 - 8.0	90.0	18.00

¹⁾ Une seule pointe.

A225

DORMER

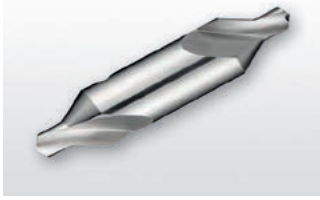

Foret à centrer en HSS avec pointe à 120° et chanfrein à 60°, finition brillante

Foret à centrer à la norme britannique 328 avec deux extrémités de perçage qui permettent d'augmenter la productivité par outil. Convient pour le perçage de nombreux matériaux.

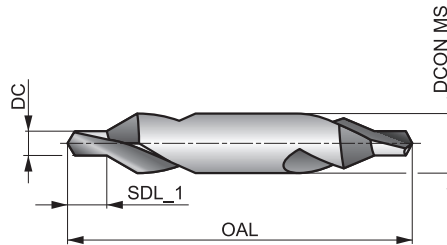

HSS	BS 328	1xD
60°	Bright	
R	120°	

Adéquation du groupe de matériaux de la pièce, valeurs de départ pour la vitesse de coupe (m/min) et code Alpha d'avance. Les tableaux d'avances par tour se trouvent à partir de la page 274.

P1.1 ■ 33 I	P1.2 ■ 37 I	P1.3 ■ 38 I	P2.1 ■ 28 I	P2.2 ■ 25 G	P2.3 ■ 22 E	P3.1 ■ 19 F	P3.2 ■ 15 F	P3.3 ■ 13 E	P4.1 ■ 11 F	P4.2 ■ 10 E	P4.3 ■ 8 D	M1.1 ■ 21 E	M1.2 ■ 17 E
M2.1 ■ 18 E	M2.2 ■ 15 E	M3.1 ■ 9 G	M3.2 ■ 8 G	M3.3 ■ 7 G	M4.1 ■ 10 C	K1.1 ■ 30 I	K1.2 ■ 22 F	K1.3 ■ 17 F	K2.1 ■ 25 E	K2.2 ■ 20 E	K2.3 ■ 16 E	K3.1 ■ 22 E	K3.2 ■ 17 E
K3.3 ■ 13 E	K4.1 ■ 20 E	K4.2 ■ 15 E	K4.3 ■ 11 E	K4.4 ■ 10 E	K4.5 ■ 8 E	K5.1 ■ 23 E	K5.2 ■ 17 E	K5.3 ■ 13 E	N1.1 ■ 33 J	N1.2 ■ 25 J	N1.3 ■ 17 I	N2.1 ■ 42 H	N2.2 ■ 37 H
N2.3 ■ 27 H	N3.1 ■ 56 H	N3.2 ■ 33 I	N3.3 ■ 17 G	N4.1 ■ 30 J	N4.2 ■ 28 H	N4.3 ■ 14 F	S1.1 ■ 24 F	S1.2 ■ 13 D	S1.3 ■ 7 B	S2.1 ■ 7 E	S2.2 ■ 6 A	S3.1 ■ 5 E	S3.2 ■ 4 A
S4.1 ■ 4 E	S4.2 ■ 3 A												

Les produits de cette série sont également disponibles en coffret. Voir A296.

Product	Nr.	DC (inch)	DC (inch)	SDL_1 (inch)	OAL (inch)	DCON MS (inch)
A225BS1	BS1	3/64	0.0469	5/64 - 1/16	1.1/2	1/8
A225BS2	BS2	1/16	0.0625	3/32 - 5/64	1.3/4	3/16
A225BS3	BS3	3/32	0.0938	5/32 - 1/8	2"	1/4
A225BS4	BS4	1/8	0.1250	3/16 - 5/32	2.1/4	5/16
A225BS5	BS5	3/16	0.1875	9/32 - 1/4	2.1/2	7/16
A225BS5A	BS5A	7/32	0.2188	5/16 - 9/32	2.3/4	1/2
A225BS6	BS6	1/4	0.2500	3/8 - 5/16	3"	5/8
A225BS7	BS7	5/16	0.3125	15/32 - 13/32	3.1/2	3/4

A242



Foret à centrer long en HSS-E (5% Co), pointe à 118°, chanfrein à 60°, finition brillante

Foret à centrer avec deux extrémités de perçage qui augmentent la productivité par outil. Convient pour percer de nombreux matériaux.

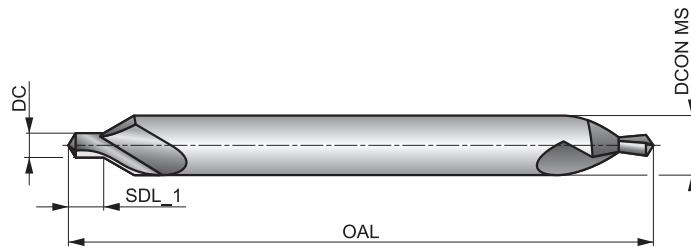

HSS-E		1xD
60°	Bright	
R	118°	

Adéquation du groupe de matériaux de la pièce, valeurs de départ pour la vitesse de coupe (m/min) et code Alpha d'avance. Les tableaux d'avances par tour se trouvent à partir de la page 274.

P1.1 ■ 33 I	P1.2 ■ 37 I	P1.3 ■ 38 I	P2.1 ■ 28 I	P2.2 ■ 25 G	P2.3 ▣ 22 E	P3.1 ■ 19 F	P3.2 ■ 15 F	P3.3 ▣ 13 E	P4.1 ■ 11 F	P4.2 ▣ 10 E	P4.3 ▣ 8 D	M1.1 ▣ 21 E	M1.2 ▣ 17 E
M2.1 ▣ 18 E	M2.2 ▣ 15 E	M3.1 ▣ 19 G	M3.2 ▣ 8 G	M3.3 ▣ 7 G	M4.1 ▣ 10 C	K1.1 ■ 30 I	K1.2 ■ 22 F	K1.3 ■ 17 F	K2.1 ▣ 25 E	K2.2 ▣ 20 E	K2.3 ▣ 16 E	K3.1 ▣ 22 E	K3.2 ▣ 17 E
K3.3 ▣ 13 E	K4.1 ▣ 20 E	K4.2 ▣ 15 E	K4.3 ▣ 11 E	K4.4 ▣ 10 E	K4.5 ▣ 8 E	K5.1 ▣ 23 E	K5.2 ▣ 17 E	K5.3 ▣ 13 E	N1.1 ▣ 33 J	N1.2 ▣ 25 J	N1.3 ▣ 17 I	N2.1 ▣ 42 H	N2.2 ▣ 37 H
N2.3 ▣ 27 H	N3.1 ▣ 56 H	N3.2 ▣ 33 I	N3.3 ▣ 17 G	N4.1 ▣ 30 J	N4.2 ▣ 28 H	N4.3 ▣ 14 F	S1.1 ▣ 24 F	S1.2 ▣ 13 D	S1.3 ▣ 7 B	S2.1 ▣ 7 E	S2.2 ▣ 6 A	S3.1 ▣ 5 E	S3.2 ▣ 4 A
S4.1 ▣ 4 E	S4.2 ▣ 3 A												

Product	DC	DC	SDL_1	OAL	DCON MS
	(mm)	(inch)			
A2421.0X4.0	1.00	0.0394	1.7 - 1.3	100.0	4.00
A2421.5X5.0	1.50	0.0591	2.6 - 2.0	100.0	5.00
A2422.0X6.0	2.00	0.0787	3.1 - 2.5	100.0	6.00
A2422.5X8.0	2.50	0.0984	3.8 - 3.1	100.0	8.00
A2423.0X8.0	3.00	0.1181	4.6 - 3.9	100.0	8.00
A2423.0X10.0	3.00	0.1181	4.6 - 3.9	100.0	10.00
A2424.0X10.0	4.00	0.1575	5.9 - 5.0	100.0	10.00
A2424.0X12.0	4.00	0.1575	5.9 - 5.0	100.0	12.00
A2425.0X12.0	5.00	0.1969	7.2 - 6.3	100.0	12.00

R200

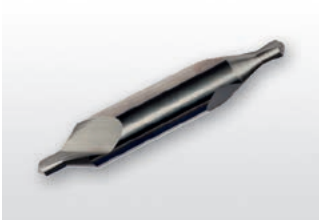

Foret à centrer en carbure monobloc, angle de pointe 118° et chanfrein à 60°, finition brillante

Foret possédant deux extrémités de perçage pour augmenter la productivité par outil, avec un angle de pointe à 118° et un lamage à 60°. Convient à un grand nombre de matériaux et sur toutes les machines CNC.

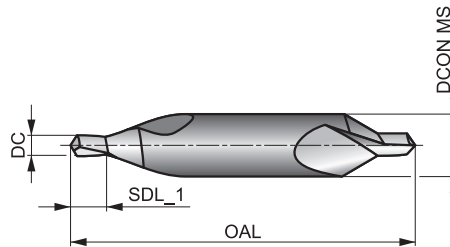

HM	DIN 333A	1xD
60°	Bright	
R		

Adéquation du groupe de matériaux de la pièce, valeurs de départ pour la vitesse de coupe (m/min) et code Alpha d'avance. Les tableaux d'avances par tour se trouvent à partir de la page 274.

P1.1 ■ 60 H	P1.2 ■ 67 H	P1.3 ■ 69 H	P2.1 ■ 51 H	P2.2 ■ 45 F	P2.3 ■ 40 D	P3.1 ■ 44 E	P3.2 ■ 36 E	P3.3 ■ 30 D	P4.1 ■ 26 E	P4.2 ■ 22 D	P4.3 ■ 18 C	K1.1 ■ 40 H	K1.2 ■ 30 E
K1.3 ■ 22 E	K2.1 ■ 37 D	K2.2 ■ 30 D	K2.3 ■ 24 D	K3.1 ■ 33 D	K3.2 ■ 25 D	K3.3 ■ 20 D	K4.1 ■ 30 D	K4.2 ■ 23 D	K4.3 ■ 17 D	K4.4 ■ 14 D	K4.5 ■ 12 D	K5.1 ■ 34 D	K5.2 ■ 26 D
K5.3 ■ 20 D	N1.1 ■ 120 I	N1.2 ■ 90 I	N1.3 ■ 60 H	N2.1 ■ 154 G	N2.2 ■ 138 G	N2.3 ■ 100 G	N3.1 ■ 169 G	N3.2 ■ 100 H	N3.3 ■ 50 F				

Product	DC	DC	SDL_1	OAL	DCON MS
	(mm)	(inch)			
R2001.0X3.15	1.00	0.0394	1.7 - 1.3	31.0	3.15
R2001.25X3.15	1.25	0.0492	2.0 - 1.6	31.0	3.15
R2001.6X4.0	1.60	0.0630	2.6 - 2.0	35.0	4.00
R2002.0X5.0	2.00	0.0787	3.1 - 2.5	40.0	5.00
R2002.5X6.3	2.50	0.0984	3.8 - 3.1	45.0	6.30
R2003.15X8.0	3.15	0.1240	4.6 - 3.9	50.0	8.00
R2004.0X10.0	4.00	0.1575	5.9 - 5.0	55.0	10.00
R2005.0X12.5	5.00	0.1969	7.2 - 6.3	63.0	12.50

A296



Coffret de forets à centrer en HSS

Coffret de cinq forets à centrer qui sont livrés dans un boîtier en plastique pratique pour garder tous vos forets ensemble. Les deux extrémités de perçage procurent plus de productivité par outil.

A296200 - 118° de pointe DIN333A, A296225 - 120° de pointe BS328. A=Types dans le coffret, B=Quantité dans le coffret, C=Diamètres dans le coffret.

Product	Nr.	A	B	C
A296200	200	A200	5	1.00 mm, 2.00 mm, 2.50 mm, 3.15 mm, 4.00 mm
A296225	225	A225	5	BS1, BS2, BS3, BS4, BS5

Code de matériau du corps (BMC)	HSS	HSS-E	HSS	HSS-E	HM	HSS	HSS	HSS	HSS
Revêtement	TIN	Bright	TIAIN	ALTiCN	Bright	TIAIN	Bright	Bright	TIN
Groupe standard de base (BSG)	DIN 334C	DORMER	DIN 335C	DIN 335C	DIN 335C	DIN 335C	DIN 334D	DIN 335D	DIN 335D
Sens (direction de coupe)	R	R	R	R	R	R	R	R	R
Queue									
Angle d'application	60°	90°	90°	90°	90°	100°	60°	90°	90°



		G335	G149	G560	G570	G400	G171	G137	G138	G338
		6.30 - 25.00	5.00 - 25.00	6.30 - 31.00	6.30 - 31.00	6.30 - 31.00	6.30 - 25.00	31.50 - 50.00	25.00 - 63.00	25.00 - 50.00
		158	159	160	161	162	163	164	165	166
P	P1	■	■	■	☒	■	■	■	■	■
	P2	■	■	■	■	■	■	■	■	■
	P3	■	■	■	■	■	■	☒	☒	■
	P4	■	■	■	■	■	■	☒	☒	■
M	M1	☒	☒	☒	■	■	☒	☒	☒	☒
	M2	☒	☒	☒	■	☒	☒	☒	☒	☒
	M3	☒	■	■	■	☒	■	■	■	■
	M4	■	■	■	☒	☒	■	■	■	■
K	K1	■	☒	■	■	■	■	☒	☒	■
	K2	■	☒	■	■	■	■	☒	☒	■
	K3	■	☒	■	■	■	■	☒	☒	■
	K4	☒	■	☒	☒	■	☒	■	■	☒
	K5	■	☒	■	■	■	■	☒	☒	■
N	N1	■	■	☒	☒	■	☒	☒	☒	■
	N2	■	☒	■	☒	■	■	☒	☒	■
	N3	■	■	■	☒	■	■	■	■	■
	N4	☒	☒	☒	■	■	☒	☒	☒	☒
	N5	■	■	■	■	■	■	■	■	■
S	S1	■	■	■	■	■	■	■	■	■
	S2	■	■	■	■	☒	■	■	■	■
	S3	■	■	■	■	☒	■	■	■	■
	S4	■	■	■	■	☒	■	■	■	■
H	H1	■	■	■	■	■	■	■	■	■
	H2	■	■	■	■	■	■	■	■	■
	H3	■	■	■	■	☒	■	■	■	■
	H4	■	■	■	■	☒	■	■	■	■

G335



Fraise en HSS à ébavurer et à chanfreiner à 60° à queue cylindrique, revêtement TiN

Fraise à chanfreiner des trous à 60° pour les trous de fixation spéciaux et pour éliminer les bavures des trous percés. Le revêtement TiN améliore les performances et prolonge la durée de vie de l'outil. Fraise polyvalente qui peut être utilisée aussi bien à la main qu'en machine. Convient pour chanfreiner les trous dans de nombreux matériaux.

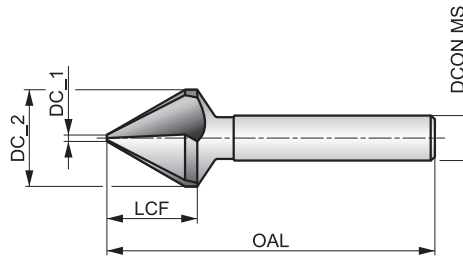

HSS	TiN	DIN 334C
R	60°	

Adéquation du groupe de matériaux de la pièce, valeurs de départ pour la vitesse de coupe (m/min) et code Alpha d'avance. Les tableaux d'avances par tour se trouvent à partir de la page 280.

P1.1 ■ 33 E	P1.2 ■ 37 E	P1.3 ■ 38 E	P2.1 ■ 28 E	P2.2 ■ 25 D	P2.3 ■ 22 B	P3.1 ■ 23 D	P3.2 ■ 18 D	P3.3 ■ 15 B	P4.1 ■ 13 D	P4.2 ■ 11 B	P4.3 ▧ 9 B	M1.1 ▧ 10 C	M1.2 ▧ 8 C
M2.1 ▧ 9 C	M3.1 ▧ 8 B	K1.1 ■ 34 F	K1.2 ■ 25 D	K1.3 ▧ 19 D	K2.1 ■ 35 C	K2.2 ■ 28 C	K2.3 ▧ 23 C	K3.1 ■ 31 C	K3.2 ■ 24 C	K3.3 ▧ 19 C	K4.1 ▧ 29 C	K4.2 ▧ 22 C	K4.3 ▧ 16 C
K5.1 ■ 32 C	K5.2 ■ 24 C	K5.3 ▧ 19 C	N1.1 ■ 53 G	N1.2 ■ 40 G	N1.3 ■ 27 F	N2.1 ■ 27 F	N2.2 ■ 24 F	N2.3 ■ 17 F	N3.1 ■ 28 F	N3.2 ■ 16 F	N3.3 ▧ 8 D	N4.1 ▧ 58 G	N4.2 ▧ 50 G

DCON MS tolérance h9.

Product	DC_2 (mm)	DC_1 (mm)	LCF (mm)	OAL (mm)	DCON MS (mm)	NOF
G3356.3	6.30	1.60	6.8	45.0	5.00	3
G3358.0	8.00	2.00	8.5	50.0	6.00	3
G33510.0	10.00	2.50	7.6	50.0	6.00	3
G33512.5	12.50	3.20	11.7	56.0	8.00	3
G33516.0	16.00	4.00	14.5	63.0	10.00	3
G33520.0	20.00	5.00	17.5	67.0	10.00	3
G33525.0	25.00	6.30	20.5	71.0	10.00	3

G149



Fraise en HSS-E à ébavurer et à chanfreiner à 90° à queue cylindrique, avec trou, finition brillante

Fraise à chanfreiner à 90° conçue pour les trous de fixation et les opérations d'ébavurage. Sa conception spécifique améliore l'évacuation des copeaux pour une opération de chanfreinage en douceur. Convient pour de très nombreux matériaux.

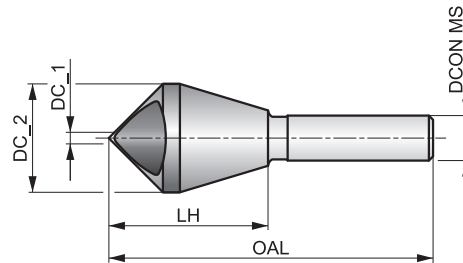

HSS-E	Bright	DORMER
R	90°	

Adéquation du groupe de matériaux de la pièce, valeurs de départ pour la vitesse de coupe (m/min) et code Alpha d'avance. Les tableaux d'avances par tour se trouvent à partir de la page 280.

P1.1 ▣21 D	P1.2 ▣24 D	P1.3 ▣25 D	P2.1 ▣18 D	P2.2 ▣16 C	P2.3 ▣14 A	P3.1 ▣16 B	P3.2 ▣13 B	M1.1 ▣8 B	M1.2 ▣6 B	M2.1 ▣7 B	K1.1 ▣18 D	K2.1 ▣19 A	K3.1 ▣16 A
K5.1 ▣14 A	N1.1 ▣34 D	N1.2 ▣25 D	N1.3 ▣16 C	N2.1 ▣16 C	N2.2 ▣14 C	N3.1 ▣17 C	N3.2 ▣9 C	N3.3 ▣5 B	N4.1 ▣17 D	N4.2 ▣5 D			

Product	DC_2 (mm)	DC_1 (mm)	LH (mm)	OAL (mm)	DCON MS (mm)	DC (mm)	NOF
G1495	5.00	2.00	19.0	45.0	6.00	10.00	1
G14910	10.00	5.00	23.0	48.0	8.00	14.00	1
G14915	15.00	10.00	34.0	65.0	10.00	21.00	1
G14920	20.00	15.00	43.0	84.0	12.00	28.00	1
G14925	25.00	20.00	48.0	102.0	15.00	35.00	1

G560

DORMER



Fraise en HSS à ébavurer et à chanfreiner à 90° à queue cylindrique, revêtement TiAlN

Fraise à chanfreiner à 90° conçue pour chanfreiner les trous de fixation standards et réaliser des opérations d'ébavurage. Sa queue réduite en diamètre permet de réaliser des chanfreins d'un plus grand diamètre. Fraise polyvalente adaptée aussi bien aux applications électro-portatives que sur machines. Son revêtement TiAlN améliore les performances et prolonge la durée de vie de l'outil.

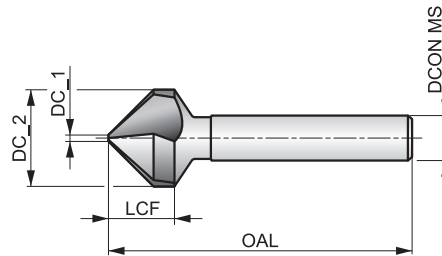

HSS	TiAlN	DIN 335C
R	90°	

Adéquation du groupe de matériaux de la pièce, valeurs de départ pour la vitesse de coupe (m/min) et code Alpha d'avance. Les tableaux d'avances par tour se trouvent à partir de la page 280.

P1.1 ■ 40 E	P1.2 ■ 45 E	P1.3 ■ 46 E	P2.1 ■ 34 E	P2.2 ■ 30 D	P2.3 ■ 27 B	P3.1 ■ 28 D	P3.2 ■ 22 D	P3.3 ■ 19 B	P4.1 ■ 16 D	P4.2 ■ 14 B	P4.3 ■ 11 B	M1.1 ■ 11 C	M1.2 ■ 9 C
M2.1 ■ 10 C	M2.2 ■ 19 C	M2.3 ■ 8 B	K1.1 ■ 41 F	K1.2 ■ 30 D	K1.3 ■ 23 D	K2.1 ■ 42 C	K2.2 ■ 34 C	K2.3 ■ 27 C	K3.1 ■ 37 C	K3.2 ■ 28 C	K3.3 ■ 23 C	K4.1 ■ 34 C	K4.2 ■ 26 C
K4.3 ■ 19 C	K5.1 ■ 39 C	K5.2 ■ 29 C	K5.3 ■ 23 C	N1.1 ■ 60 G	N1.2 ■ 45 G	N1.3 ■ 30 F	N2.1 ■ 30 F	N2.2 ■ 27 F	N2.3 ■ 19 F	N3.1 ■ 32 F	N3.2 ■ 18 F	N3.3 ■ 19 D	N4.1 ■ 62 G
N4.2 ■ 55 G													

DCON MS tolérance h9.

Les produits de cette série sont également disponibles en coffret. Voir G236.

Product	DC_2 (mm)	DC_1 (mm)	LCF (mm)	OAL (mm)	DCON MS (mm)	NOF
G5606.3	6.30	1.50	5.5	45.0	5.00	3
G5608.0	8.00	2.00	6.1	50.0	6.00	3
G5608.3	8.30	2.00	6.5	50.0	6.00	3
G56010.0	10.00	2.50	7.6	50.0	6.00	3
G56010.4	10.40	2.50	7.6	50.0	6.00	3
G56012.4	12.40	2.80	8.5	56.0	8.00	3
G56016.5	16.50	3.20	10.5	60.0	10.00	3
G56020.5	20.50	3.50	13.0	63.0	10.00	3
G56025.0	25.00	3.80	15.5	67.0	10.00	3
G56031.0	31.00	4.20	18.5	71.0	12.00	3

G570

DORMER



Fraise en HSS-E à ébavurer et à chanfreiner à 90° à queue cylindrique, revêtement AlTiCN

Fraise à 90° conçue pour les trous de fixation standards et les opérations d'ébavurage. Elle peut être utilisée aussi bien pour les applications électro-portatives que sur machines. Particulièrement adaptée au chanfreinage de trous dans des matériaux durs et abrasifs. Son revêtement AlTiCN améliore les performances et prolonge la durée de vie de l'outil.

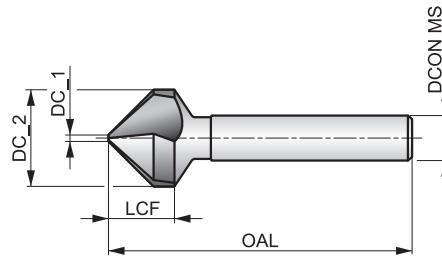

HSS-E	AlTiCN	DIN 335C
R	90°	

Adéquation du groupe de matériaux de la pièce, valeurs de départ pour la vitesse de coupe (m/min) et code Alpha d'avance. Les tableaux d'avances par tour se trouvent à partir de la page 280.

P1.1 ■ 40 E	P1.2 ■ 45 E	P1.3 ■ 46 E	P2.1 ■ 34 E	P2.2 ■ 30 D	P2.3 ■ 27 B	P3.1 ■ 28 D	P3.2 ■ 22 D	P3.3 ■ 19 B	P4.1 ■ 16 D	P4.2 ■ 14 B	P4.3 ■ 11 B	M1.1 ■ 23 C	M1.2 ■ 20 C
M2.1 ■ 21 C	M2.2 ■ 17 C	M2.3 ■ 14 A	M3.1 ■ 14 B	M3.2 ■ 12 B	M3.3 ■ 11 B	M4.1 ■ 15 A	M4.2 ■ 13 A	K1.1 ■ 41 C	K1.2 ■ 30 C	K1.3 ■ 23 C	K2.1 ■ 42 C	K2.2 ■ 34 C	K2.3 ■ 27 C
K3.1 ■ 37 C	K3.2 ■ 28 C	K3.3 ■ 23 C	K4.1 ■ 34 C	K4.2 ■ 26 C	K4.3 ■ 19 C	K5.1 ■ 39 C	K5.2 ■ 29 C	K5.3 ■ 23 C	N1.1 ■ 60 G	N1.2 ■ 45 G	N1.3 ■ 30 F	N2.1 ■ 30 F	N2.2 ■ 27 F
N2.3 ■ 19 F	N3.1 ■ 32 F	N3.2 ■ 18 F	N3.3 ■ 9 D										

DCON MS tolérance h9.

Product	DC_2 (mm)	DC_1 (mm)	LCF (mm)	OAL (mm)	DCON MS (mm)	NOF
G5706.3	6.30	1.50	6.5	45.0	5.00	3
G5708.3	8.30	2.00	8.2	50.0	6.00	3
G57010.4	10.40	2.50	9.7	50.0	6.00	3
G57012.4	12.40	2.80	10.6	56.0	8.00	3
G57016.5	16.50	3.20	13.9	60.0	10.00	3
G57020.5	20.50	3.50	17.1	63.0	10.00	3
G57025.0	25.00	3.80	21.4	67.0	10.00	3
G57031.0	31.00	4.20	24.4	71.0	12.00	3

G400

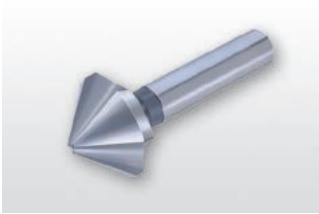

Fraise en carbure à ébavurer et à chanfreiner à 90° à queue cylindrique, finition brillante

Fraise à chanfreiner 90° haute performance avec finition brillante, conçue pour être utilisée sur des machines CNC où une productivité et une qualité élevée sont requises. Peut être utilisée pour chanfreiner des trous dans des matériaux durs et abrasifs. L'angle de 90° permet de chanfreiner les trous de fixation standards pour des vis à têtes fraisées à 90°.

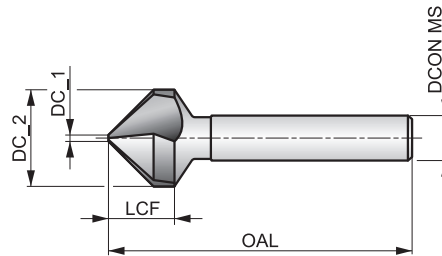

HM	Bright	DIN 335C
R	90°	

Adéquation du groupe de matériaux de la pièce, valeurs de départ pour la vitesse de coupe (m/min) et code Alpha d'avance. Les tableaux d'avances par tour se trouvent à partir de la page 280.

P1.1 ■ 64 E	P1.2 ■ 72 E	P1.3 ■ 74 E	P2.1 ■ 55 E	P2.2 ■ 48 D	P2.3 ■ 43 B	P3.1 ■ 45 D	P3.2 ■ 36 D	P3.3 ■ 30 B	P4.1 ■ 26 D	P4.2 ■ 23 B	P4.3 ■ 18 A	M1.1 ■ 24 C	M1.2 ■ 21 C
M2.1 ■ 22 C	M2.2 ▣ 18 C	M2.3 ▣ 15 B	M3.1 ■ 20 B	M3.2 ▣ 17 B	M3.3 ▣ 15 B	M4.1 ▣ 15 A	M4.2 ▣ 13 A	K1.1 ■ 45 F	K1.2 ■ 33 D	K1.3 ■ 25 D	K2.1 ■ 46 C	K2.2 ■ 37 C	K2.3 ▣ 30 C
K3.1 ■ 41 C	K3.2 ■ 31 C	K3.3 ▣ 25 C	K4.1 ■ 38 C	K4.2 ■ 28 C	K4.3 ■ 21 C	K4.4 ▣ 18 C	K4.5 ▣ 15 C	K5.1 ■ 43 C	K5.2 ■ 32 C	K5.3 ■ 25 C	N1.1 ▣ 75 G	N1.2 ■ 55 G	N1.3 ■ 40 F
N2.1 ■ 40 F	N2.2 ■ 36 F	N2.3 ■ 26 F	N3.1 ■ 42 F	N3.2 ■ 25 F	N3.3 ▣ 13 D	N4.3 ■ 17 E	S1.1 ■ 12 C	S1.2 ■ 10 A	S1.3 ▣ 9 A	S2.1 ■ 8 B	S2.2 ▣ 7 A	S3.1 ■ 6 B	S3.2 ▣ 5 A
S4.1 ■ 5 B	S4.2 ▣ 4 A	H1.1 ■ 12 A	H2.1 ■ 7 A	H2.2 ▣ 6 B	H3.1 ■ 8 A	H3.2 ▣ 7 B	H4.1 ■ 5 A	H4.2 ▣ 4 B					

DCON MS tolérance h6.

Product	DC_2 (mm)	DC_1 (mm)	LCF (mm)	OAL (mm)	DCON MS (mm)	NOF
G4006.3	6.30	1.50	5.0	45.0	5.00	3
G4008.3	8.30	2.00	6.0	50.0	6.00	3
G40010.4	10.40	2.50	7.1	50.0	6.00	3
G40012.4	12.40	2.80	8.0	56.0	8.00	3
G40016.5	16.50	3.20	10.0	60.0	10.00	3
G40020.5	20.50	3.50	12.5	63.0	10.00	3
G40025.0	25.00	3.80	15.0	67.0	10.00	3
G40031.0	31.00	4.20	18.0	71.0	12.00	3

G171

DORMER



Fraise en HSS à ébavurer et à chanfreiner à 100° à queue cylindrique

Fraise à chanfreiner à 100° conçue pour les trous de fixation standards et les opérations d'ébavurage. Outil polyvalent avec un revêtement TiAlN qui améliore les performances et prolonge la durée de vie de l'outil dans la plupart des matériaux. Elle peut être utilisée aussi bien pour les applications électro-portatives que sur machines.

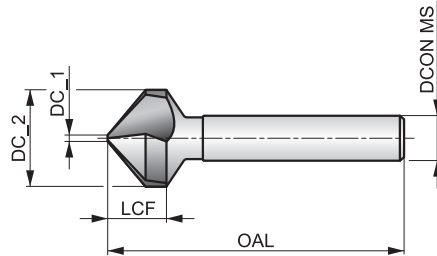

HSS	TiAlN	DIN 335C
R	100°	

Adéquation du groupe de matériaux de la pièce, valeurs de départ pour la vitesse de coupe (m/min) et code Alpha d'avance. Les tableaux d'avances par tour se trouvent à partir de la page 280.

P1.1 ■ 40 E	P1.2 ■ 45 E	P1.3 ■ 46 E	P2.1 ■ 34 E	P2.2 ■ 30 D	P2.3 ■ 27 B	P3.1 ■ 28 D	P3.2 ■ 22 D	P3.3 ■ 19 B	P4.1 ■ 16 D	P4.2 ■ 14 B	P4.3 ■ 11 B	M1.1 ■ 11 C	M1.2 ■ 9 C
M2.1 ■ 10 C	K1.1 ■ 41 F	K1.2 ■ 30 D	K1.3 ■ 23 D	K2.1 ■ 42 C	K2.2 ■ 34 C	K2.3 ■ 27 C	K3.1 ■ 37 C	K3.2 ■ 28 C	K3.3 ■ 23 C	K4.1 ■ 34 C	K4.2 ■ 26 C	K4.3 ■ 19 C	K5.1 ■ 39 C
K5.2 ■ 29 C	K5.3 ■ 23 C	N1.1 ■ 60 G	N1.2 ■ 45 G	N1.3 ■ 30 F	N2.1 ■ 30 F	N2.2 ■ 27 F	N2.3 ■ 19 F	N3.1 ■ 32 F	N3.2 ■ 18 F	N3.3 ■ 9 D	N4.1 ■ 62 G	N4.2 ■ 55 G	

DCON MS tolérance h9.

Product	DC_2 (mm)	DC_1 (mm)	LCF (mm)	OAL (mm)	DCON MS (mm)	NOF
G1716.3	6.30	1.50	4.5	44.0	5.00	3
G1718.3	8.30	2.00	5.5	49.0	6.00	3
G17110.4	10.40	2.50	6.6	49.0	6.00	3
G17112.4	12.40	2.80	7.0	53.0	8.00	3
G17116.5	16.50	3.20	9.0	56.0	10.00	3
G17120.5	20.50	3.50	11.0	61.0	10.00	3
G17125.0	25.00	3.80	13.5	65.0	10.00	3

G137



Fraise en HSS à ébavurer et à chanfreiner à 60° à queue cône morse, finition brillante

Fraises à chanfreiner à finition brillante avec un angle de 60° pour les trous de fixation spéciaux et pour éliminer les bavures des trous percés. La conception de la queue conique permet d'utiliser l'outil dans des applications sur machines où il est maintenu directement dans la broche. Convient pour chanfreiner les trous dans de nombreux matériaux.

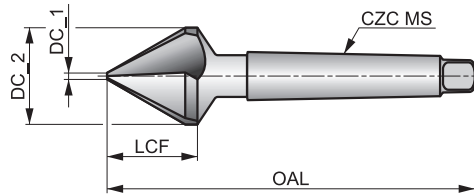

HSS	Bright	DIN 334D
R		60°

Adéquation du groupe de matériaux de la pièce, valeurs de départ pour la vitesse de coupe (m/min) et code Alpha d'avance. Les tableaux d'avances par tour se trouvent à partir de la page 280.

P1.1 ■ 23 E	P1.2 ■ 26 E	P1.3 ■ 27 E	P2.1 ■ 20 E	P2.2 ■ 18 D	P2.3 ▣ 16 B	P3.1 ■ 16 D	P3.2 ▣ 13 D	P3.3 ▣ 11 B	P4.1 ■ 10 D	P4.2 ▣ 8 B	M1.1 ▣ 8 C	M1.2 ▣ 16 C	M2.1 ▣ 17 C
M2.2 ▣ 16 C	K1.1 ▣ 20 F	K1.2 ▣ 15 D	K2.1 ▣ 21 C	K2.2 ▣ 17 C	K3.1 ▣ 18 C	K3.2 ▣ 14 C	K5.1 ▣ 19 C	K5.2 ▣ 15 C	N1.1 ▣ 40 G	N1.2 ■ 30 G	N1.3 ▣ 20 F	N2.1 ■ 20 F	N2.2 ▣ 18 F
N3.1 ■ 21 F	N3.2 ■ 12 F	N3.3 ▣ 16 D	N4.1 ▣ 40 G	N4.2 ▣ 35 G									

Product	DC_2 (mm)	DC_1 (mm)	LCF (mm)	OAL (mm)	CZC MS	NOF
G13731.5	31.50	10.00	23.0	118.0	MK 2	3
G13740.0	40.00	12.50	28.5	150.0	MK 3	3
G13750.0	50.00	16.00	36.0	160.0	MK 3	3

G138



Fraise en HSS à ébavurer et à chanfreiner à 90° à queue cône morse, finition brillante

Fraise à chanfreiner à 90° conçue pour les trous de fixation standards et réaliser des opérations d'ébavurage. Attachements en cône morse tailles de 2 à 4 pour une fixation directe dans la broche de la machine. Convient dans de très nombreux matériaux.

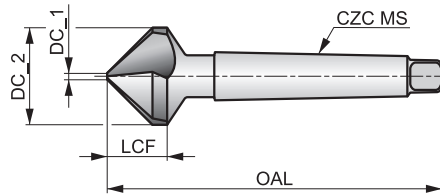

HSS	Bright	DIN 335D
R		90°

Adéquation du groupe de matériaux de la pièce, valeurs de départ pour la vitesse de coupe (m/min) et code Alpha d'avance. Les tableaux d'avances par tour se trouvent à partir de la page 280.

P1.1 ■ 23 E	P1.2 ■ 26 E	P1.3 ■ 27 E	P2.1 ■ 20 E	P2.2 ■ 18 D	P2.3 ▧ 16 B	P3.1 ■ 16 D	P3.2 ▧ 13 D	P3.3 ▧ 11 B	P4.1 ■ 10 D	P4.2 ▧ 8 B	M1.1 ▧ 8	M1.2 ▧ 6	M2.1 ▧ 7
M2.2 ▧ 6	K1.1 ▧ 20 F	K1.2 ▧ 15 D	K2.1 ▧ 21 C	K2.2 ▧ 17 C	K3.1 ▧ 18 C	K3.2 ▧ 14 C	K5.1 ▧ 19 C	K5.2 ▧ 15 C	N1.1 ▧ 40 G	N1.2 ■ 30 G	N1.3 ▧ 20 F	N2.1 ■ 20 F	N2.2 ▧ 18 F
N3.1 ■ 21 F	N3.2 ■ 12 F	N3.3 ▧ 16 D	N4.1 ▧ 40 G	N4.2 ▧ 35 G									

Product	DC_2 (mm)	DC_1 (mm)	LCF (mm)	OAL (mm)	CZC MS	NOF
G13825.0	25.00	3.80	15.5	106.0	MK 2	3
G13830.0	30.00	4.20	18.5	112.0	MK 2	3
G13831.0	31.00	4.20	20.0	112.0	MK 2	3
G13834.0	34.00	4.50	19.5	118.0	MK 2	3
G13837.0	37.00	4.80	21.7	118.0	MK 2	3
G13840.0	40.00	10.00	20.5	140.0	MK 3	3
G13850.0	50.00	14.00	24.1	150.0	MK 3	3
G13863.0	63.00	16.00	28.5	180.0	MK 4	3

G338

DORMER

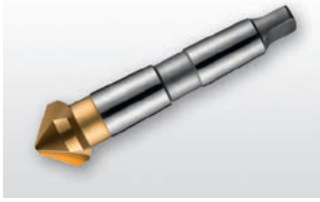

Fraise en HSS à ébavurer et à chanfreiner à 90° à queue cône morse, revêtement TiN

Fraise à chanfreiner à 90° conçue pour les trous de fixation standards et réaliser des opérations d'ébavurage. Attachements en cône morse tailles de 2 à 4 pour une fixation directe dans la broche de la machine. Son revêtement TiN améliore la performance et prolonge la durée de vie de l'outil dans des vitesses de coupe élevées. Convient pour chanfreiner dans de très nombreux matériaux.

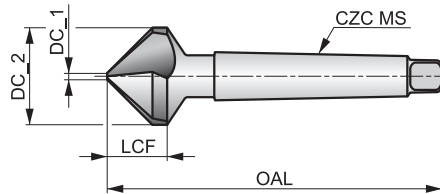

HSS	TiN	DIN 335D
R	90°	

Adéquation du groupe de matériaux de la pièce, valeurs de départ pour la vitesse de coupe (m/min) et code Alpha d'avance. Les tableaux d'avances par tour se trouvent à partir de la page 280.

P1.1 ■ 33 E	P1.2 ■ 37 E	P1.3 ■ 38 E	P2.1 ■ 28 E	P2.2 ■ 25 D	P2.3 ■ 22 B	P3.1 ■ 23 D	P3.2 ■ 18 D	P3.3 ■ 15 B	P4.1 ■ 13 D	P4.2 ■ 11 B	P4.3 ▣ 9 B	M1.1 ▣ 11 C	M1.2 ▣ 9 C
M2.1 ▣ 10 C	M2.2 ▣ 19 C	M2.3 ▣ 8 B	K1.1 ■ 34 F	K1.2 ■ 25 D	K1.3 ▣ 19 D	K2.1 ■ 35 C	K2.2 ■ 28 C	K2.3 ▣ 23 C	K3.1 ■ 31 C	K3.2 ■ 24 C	K3.3 ▣ 19 C	K4.1 ▣ 29 C	K4.2 ▣ 22 C
K4.3 ▣ 16 C	K5.1 ■ 32 C	K5.2 ■ 24 C	K5.3 ▣ 19 C	N1.1 ■ 53 G	N1.2 ■ 40 G	N1.3 ■ 27 F	N2.1 ■ 27 F	N2.2 ■ 24 F	N2.3 ■ 17 F	N3.1 ■ 28 F	N3.2 ■ 16 F	N3.3 ▣ 18 D	N4.1 ▣ 15 G
N4.2 ▣ 50 G													

Product	DC_2 (mm)	DC_1 (mm)	LCF (mm)	OAL (mm)	CZC MS	NOF
G33825.0	25.00	3.80	15.5	106.0	MK 2	3
G33831.0	31.00	4.20	20.0	112.0	MK 2	3
G33837.0	37.00	4.80	21.7	118.0	MK 2	3
G33840.0	40.00	10.00	20.5	140.0	MK 3	3
G33850.0	50.00	14.00	24.1	150.0	MK 3	3

Code de matériau du corps (BMC)

Revêtement

Groupe standard de base (BSG)

Sens (direction de coupe)

Queue

Forme d'alésoir

Tolérance de trou réalisable (TCHA)

Dégradé conique - millimètre

HSS-E	HSS-E	HSS-E	HSS-E	HSS-E	HSS-E	HSS	HSS
Bright ST	Bright	Bright	Bright	Bright ST	Bright	Bright ST	ST
BS 328	DIN 212	DIN 212	DIN 208	BS 328	DIN 2180	DIN 311	ANSI
B	B	B	B	B	B		
H7	H7	$\begin{matrix} \phi 95-5.5 \\ +0.004 \\ \phi 5.51-12 \\ +0.005 \end{matrix}$	H7	H7		k11	
					1:50		



Code de famille de produits

Plage de diamètres de coupe PSF

B901	B180	B170	B161	B101	B954	B121	B640
1.50 - 1/2	1.50 - 20.00	1.00 - 12.00	3.00 - 50.00	3.00 - 50.00	8.00 - 30.00	12.00 - 25.00	7/16 - 1.1/16
168	169	171	173	174	175	176	177

P	P1	■	■	■	■	■	■	
	P2	■	■	■	■	■	■	
	P3	■	■	■	■	■	■	
	P4	▣	▣	▣	▣	▣	▣	■
M	M1	▣	▣	▣	▣	▣		
	M2	▣	▣	▣	▣	▣		
	M3							
	M4							
K	K1	■	■	■	■	■	■	
	K2	■	■	■	■	■	■	
	K3	▣	▣	▣	▣	▣	▣	▣
	K4							
	K5							
N	N1	■	■	■	■	■	■	
	N2	■	■	■	■	■	■	
	N3	■	■	■	■	■	■	
	N4	▣	▣	▣	▣	▣	▣	▣
	N5							
S	S1							
	S2							
	S3							
	S4							
H	H1							
	H2							
	H3							
	H4							

B901



Alésoir machine en HSS-E à queue cylindrique, précision H7, finition brillante et ST

Alésoir avec géométrie rectifiée avec précision, hélice à gauche et coupe à droite. Améliore la taille des trous et la finition de surface. L'alésoir a une queue cylindrique pour un alésage de haute performance sur machines. Convient pour l'alésage dans de nombreux matériaux.

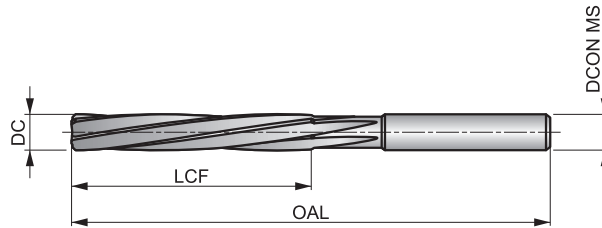

HSS-E	Bright ST	BS 328
R		B
H7		

Adéquation du groupe de matériaux de la pièce, valeurs de départ pour la vitesse de coupe (m/min) et code Alpha d'avance. Les tableaux d'avances par tour se trouvent à partir de la page 279.

P1.1 ■ 15 C	P1.2 ■ 16 C	P1.3 ■ 17 C	P2.1 ■ 13 C	P2.2 ■ 11 C	P2.3 ▣ 10 B	P3.1 ■ 7 B	P3.2 ■ 6 B	P3.3 ▣ 5 B	P4.1 ■ 4 B	P4.2 ▣ 4 B	P4.3 ▣ 3 A	M1.1 ▣ 10 C	M1.2 ▣ 8 C
M2.1 ▣ 9 C	K1.1 ■ 14 E	K1.2 ■ 10 D	K1.3 ▣ 8 D	K2.1 ■ 12 C	K2.2 ■ 10 C	K2.3 ▣ 8 C	K3.1 ▣ 11 C	K3.2 ▣ 8 C	N1.1 ▣ 23 F	N1.2 ■ 17 F	N1.3 ■ 12 F	N2.1 ■ 25 E	N2.2 ■ 22 E
N2.3 ▣ 14 E	N3.1 ■ 34 D	N3.2 ■ 20 E	N3.3 ■ 10 D	N4.1 ▣ 22 B	N4.2 ▣ 21 B								

Product	DC (inch)	DC (mm)	OAL (mm)	LCF (mm)	NOF (mm)	DCON MS (mm)
B9011.5	–	1.50	44.0	21.0	4	1.50
B9012.0	–	2.00	50.0	25.0	4	2.00
B9013/32	3/32	2.38	58.0	29.0	4	2.38
B9012.5	–	2.50	58.0	29.0	4	2.50
B9013.0	–	3.00	62.0	31.0	4	3.00
B9011/8	1/8	3.18	66.0	33.0	4	3.18
B9015/32	5/32	3.97	76.0	38.0	6	3.97
B9014.0	–	4.00	76.0	38.0	6	4.00
B9013/16	3/16	4.76	87.0	44.0	6	4.76
B9015.0	–	5.00	87.0	44.0	6	5.00
B90115/64	15/64	5.95	93.0	47.0	6	5.95
B9016.0	–	6.00	93.0	47.0	6	6.00

Product	DC (inch)	DC (mm)	OAL (mm)	LCF (mm)	NOF (mm)	DCON MS (mm)
B9011/4	1/4	6.35	100.0	50.0	6	6.35
B9017.0	–	7.00	107.0	54.0	6	7.00
B9019/32	9/32	7.14	107.0	54.0	6	7.14
B9015/16	5/16	7.94	115.0	58.0	6	7.94
B9018.0	–	8.00	115.0	58.0	6	8.00
B9019.0	–	9.00	124.0	62.0	6	9.00
B9013/8	3/8	9.52	133.0	66.0	6	9.52
B90110.0	–	10.00	133.0	66.0	6	10.00
B90111.0	–	11.00	142.0	71.0	6	11.00
B9017/16	7/16	11.11	142.0	71.0	6	11.11
B90112.0	–	12.00	152.0	76.0	6	12.00
B9011/2	1/2	12.70	152.0	76.0	6	12.70

B180



Alésoir machine en HSS-E à queue cylindrique pour précision H7, finition brillante

Alésoir haute performance pour les machines CNC à monter dans des porte-outils ou mandrins de haute précision. L'hélice à gauche rectifiée avec précision et l'action de coupe à droite assurent un alésage en douceur et améliorent la finition de surface et la taille des trous. Convient pour l'alésage dans de nombreux matériaux.

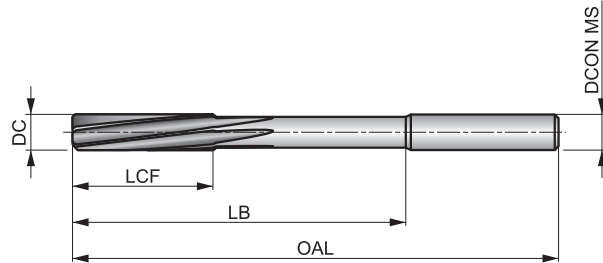

HSS-E	Bright	DIN 212
R	DIN 6535HA	B
H7		

Adéquation du groupe de matériaux de la pièce, valeurs de départ pour la vitesse de coupe (m/min) et code Alpha d'avance. Les tableaux d'avances par tour se trouvent à partir de la page 279.

P1.1 ■ 21 C	P1.2 ■ 24 C	P1.3 ■ 25 C	P2.1 ■ 18 C	P2.2 ■ 16 C	P2.3 ■ 14 B	P3.1 ■ 13 B	P3.2 ■ 11 B	P3.3 ■ 9 B	P4.1 ■ 8 B	P4.2 ■ 7 B	P4.3 ■ 5 A	M1.1 ■ 11 C	M1.2 ■ 10 B
M2.1 ■ 9 B	K1.1 ■ 16 E	K1.2 ■ 12 D	K1.3 ■ 9 D	K2.1 ■ 16 C	K2.2 ■ 13 C	K2.3 ■ 10 C	K3.1 ■ 14 C	K3.2 ■ 11 C	N1.1 ■ 24 F	N1.2 ■ 18 F	N1.3 ■ 11 F	N2.1 ■ 27 E	N2.2 ■ 24 E
N2.3 ■ 16 E	N3.1 ■ 47 D	N3.2 ■ 28 E	N3.3 ■ 14 D	N4.1 ■ 30 B									

DCON MS tolérance h6.

Product	DC	OAL	LCF	LB	NOF	DCON MS
	(mm)	(mm)	(mm)	(mm)		(mm)
B1801.5	1.50	40.0	8.0	18.00	3	2.00
B1801.6	1.60	43.0	9.0	20.00	3	2.00
B1801.7	1.70	43.0	9.0	20.00	3	2.00
B1801.8	1.80	46.0	10.0	22.00	4	2.00
B1801.9	1.90	46.0	10.0	22.00	4	2.00
B1802.0	2.00	49.0	11.0	24.00	4	2.00
B1802.1	2.10	49.0	11.0	24.00	4	2.00
B1802.2	2.20	53.0	12.0	26.00	4	3.00
B1802.3	2.30	53.0	12.0	26.00	4	3.00
B1802.4	2.40	57.0	14.0	28.00	4	3.00
B1802.5	2.50	57.0	14.0	28.00	4	3.00
B1802.6	2.60	57.0	14.0	28.00	4	3.00
B1802.7	2.70	61.0	15.0	32.00	6	3.00
B1802.8	2.80	61.0	15.0	32.00	6	3.00
B1802.9	2.90	61.0	15.0	32.00	6	3.00
B1803.0	3.00	61.0	15.0	32.00	6	3.00
B1803.1	3.10	65.0	16.0	35.00	6	4.00
B1803.2	3.20	65.0	16.0	35.00	6	4.00
B1803.3	3.30	65.0	16.0	35.00	6	4.00
B1803.4	3.40	70.0	18.0	40.00	6	4.00
B1803.5	3.50	70.0	18.0	40.00	6	4.00
B1803.6	3.60	70.0	18.0	40.00	6	4.00
B1803.9	3.90	75.0	19.0	43.00	6	4.00
B1804.0	4.00	75.0	19.0	43.00	6	4.00
B1804.1	4.10	75.0	19.0	43.00	6	4.00
B1804.2	4.20	75.0	19.0	43.00	6	4.00
B1804.3	4.30	80.0	21.0	47.00	6	5.00

Product	DC	OAL	LCF	LB	NOF	DCON MS
	(mm)	(mm)	(mm)	(mm)		(mm)
B1804.5	4.50	80.0	21.0	47.00	6	5.00
B1804.6	4.60	80.0	21.0	47.00	6	5.00
B1804.7	4.70	80.0	21.0	47.00	6	5.00
B1804.8	4.80	86.0	23.0	52.00	6	5.00
B1804.9	4.90	86.0	23.0	52.00	6	5.00
B1805.0	5.00	86.0	23.0	52.00	6	5.00
B1805.1	5.10	86.0	23.0	52.00	6	5.00
B1805.2	5.20	86.0	23.0	52.00	6	5.00
B1805.3	5.30	86.0	23.0	52.00	6	5.00
B1805.4	5.40	93.0	26.0	57.00	6	6.00
B1805.5	5.50	93.0	26.0	57.00	6	6.00
B1805.6	5.60	93.0	26.0	57.00	6	6.00
B1805.7	5.70	93.0	26.0	57.00	6	6.00
B1805.9	5.90	93.0	26.0	57.00	6	6.00
B1806.0	6.00	93.0	26.0	57.00	6	6.00
B1806.1	6.10	101.0	28.0	63.00	6	6.00
B1806.2	6.20	101.0	28.0	63.00	6	6.00
B1806.3	6.30	101.0	28.0	63.00	6	6.00
B1806.4	6.40	101.0	28.0	63.00	6	6.00
B1806.5	6.50	101.0	28.0	63.00	6	6.00
B1806.6	6.60	101.0	28.0	63.00	6	6.00
B1806.7	6.70	101.0	28.0	63.00	6	6.00
B1806.8	6.80	109.0	31.0	69.00	6	8.00
B1807.0	7.00	109.0	31.0	69.00	6	8.00
B1807.1	7.10	109.0	31.0	69.00	6	8.00
B1807.2	7.20	109.0	31.0	69.00	6	8.00
B1807.5	7.50	109.0	31.0	69.00	6	8.00



Product	DC	OAL	LCF	LB	NOF	D CON MS
	(mm)	(mm)	(mm)	(mm)		(mm)
B1807.8	7.80	117.0	33.0	75.00	6	8.00
B1807.9	7.90	117.0	33.0	75.00	6	8.00
B1808.0	8.00	117.0	33.0	75.00	6	8.00
B1808.1	8.10	117.0	33.0	75.00	6	8.00
B1808.2	8.20	117.0	33.0	75.00	6	8.00
B1808.3	8.30	117.0	33.0	75.00	6	8.00
B1808.4	8.40	117.0	33.0	75.00	6	8.00
B1808.5	8.50	117.0	33.0	75.00	6	8.00
B1808.7	8.70	125.0	36.0	81.00	6	10.00
B1808.8	8.80	125.0	36.0	81.00	6	10.00
B1809.0	9.00	125.0	36.0	81.00	6	10.00
B1809.5	9.50	125.0	36.0	81.00	6	10.00

Product	DC	OAL	LCF	LB	NOF	D CON MS
	(mm)	(mm)	(mm)	(mm)		(mm)
B1809.6	9.60	133.0	38.0	87.00	6	10.00
B18010.0	10.00	133.0	38.0	87.00	6	10.00
B18011.0	11.00	142.0	41.0	96.00	6	10.00
B18012.0	12.00	151.0	44.0	105.00	6	10.00
B18013.0	13.00	151.0	44.0	105.00	6	10.00
B18014.0	14.00	160.0	47.0	110.00	8	14.00
B18015.0	15.00	162.0	50.0	112.00	8	14.00
B18016.0	16.00	170.0	52.0	120.00	8	14.00
B18017.0	17.00	175.0	54.0	123.00	8	14.00
B18018.0	18.00	182.0	56.0	130.00	8	14.00
B18019.0	19.00	189.0	58.0	131.00	8	16.00
B18020.0	20.00	195.0	60.0	137.00	8	16.00

B170

DORMER



Alésoir machine en HSS-E à queue cylindrique - Incréments de 0,01 mm, finition brillante

Alésoir disponible dans différentes tailles d'incrément au centième vous permettent de produire des tailles de trous précises et des tolérances de trous supplémentaires. Avec une hélice à gauche et une action de coupe à droite, la géométrie rectifiée avec précision permet un alésage en douceur et améliore la taille des trous et la finition de surface. Convient pour l'alésage dans de nombreux matériaux.

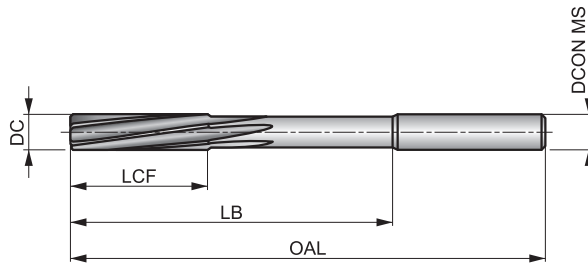

HSS-E	Bright	DIN 212
R		B
ø 95-5.5 +0.004 ø 5.51-12 +0.005		

Adéquation du groupe de matériaux de la pièce, valeurs de départ pour la vitesse de coupe (m/min) et code Alpha d'avance. Les tableaux d'avances par tour se trouvent à partir de la page 279.

P1.1 ■ 21 C	P1.2 ■ 24 C	P1.3 ■ 25 C	P2.1 ■ 18 C	P2.2 ■ 16 C	P2.3 ■ 14 B	P3.1 ■ 13 B	P3.2 ■ 11 B	P3.3 ■ 9 B	P4.1 ■ 8 B	P4.2 ■ 7 B	P4.3 ■ 5 A	M1.1 ■ 11 C	M1.2 ■ 10 B
M2.1 ■ 9 B	K1.1 ■ 16 E	K1.2 ■ 12 D	K1.3 ■ 9 D	K2.1 ■ 16 C	K2.2 ■ 13 C	K2.3 ■ 10 C	K3.1 ■ 14 C	K3.2 ■ 11 C	N1.1 ■ 24 D	N1.2 ■ 18 F	N1.3 ■ 11 F	N2.1 ■ 27 E	N2.2 ■ 24 E
N2.3 ■ 16 E	N3.1 ■ 47 D	N3.2 ■ 28 E	N3.3 ■ 14 D	N4.1 ■ 30 B									

DCON MS tolérance h9.

Product	DC (mm)	OAL (mm)	LCF (mm)	LB (mm)	NOF	DCON MS (mm)
B1701.0	1.00	34.0	5.5	15.00	3	1.00
B1701.05	1.05	34.0	5.5	15.00	3	1.00
B1701.49	1.49	40.0	8.0	18.00	3	1.50
B1701.5	1.50	40.0	8.0	18.00	3	1.50
B1701.52	1.52	43.0	9.0	20.00	3	1.60
B1701.98	1.98	49.0	11.0	24.00	4	2.00
B1701.99	1.99	49.0	11.0	24.00	4	2.00
B1702.0	2.00	49.0	11.0	24.00	4	2.00
B1702.01	2.01	49.0	11.0	24.00	4	2.00
B1702.02	2.02	49.0	11.0	24.00	4	2.00
B1702.03	2.03	49.0	11.0	24.00	4	2.00
B1702.05	2.05	49.0	11.0	24.00	4	2.00
B1702.5	2.50	57.0	14.0	28.00	4	2.50
B1702.51	2.51	57.0	14.0	28.00	4	2.50
B1702.98	2.98	61.0	15.0	32.00	6	3.00
B1702.99	2.99	61.0	15.0	32.00	6	3.00
B1703.0	3.00	61.0	15.0	32.00	6	3.00
B1703.01	3.01	65.0	16.0	35.00	6	3.20
B1703.02	3.02	65.0	16.0	35.00	6	3.20
B1703.03	3.03	65.0	16.0	35.00	6	3.20
B1703.05	3.05	65.0	16.0	35.00	6	3.20
B1703.98	3.98	75.0	19.0	43.00	6	4.00
B1703.99	3.99	75.0	19.0	43.00	6	4.00
B1704.0	4.00	75.0	19.0	43.00	6	4.00
B1704.01	4.01	75.0	19.0	43.00	6	4.00
B1704.02	4.02	75.0	19.0	43.00	6	4.00
B1704.03	4.03	75.0	19.0	43.00	6	4.00

Product	DC (mm)	OAL (mm)	LCF (mm)	LB (mm)	NOF	DCON MS (mm)
B1704.04	4.04	75.0	19.0	43.00	6	4.00
B1704.05	4.05	75.0	19.0	43.00	6	4.00
B1704.98	4.98	86.0	23.0	52.00	6	5.00
B1704.99	4.99	86.0	23.0	52.00	6	5.00
B1705.0	5.00	86.0	23.0	52.00	6	5.00
B1705.01	5.01	86.0	23.0	52.00	6	5.00
B1705.02	5.02	86.0	23.0	52.00	6	5.00
B1705.03	5.03	86.0	23.0	52.00	6	5.00
B1705.04	5.04	86.0	23.0	52.00	6	5.00
B1705.05	5.05	86.0	23.0	52.00	6	5.00
B1705.5	5.50	93.0	26.0	57.00	6	5.60
B1705.98	5.98	93.0	26.0	57.00	6	5.60
B1705.99	5.99	93.0	26.0	57.00	6	5.60
B1706.0	6.00	93.0	26.0	57.00	6	5.60
B1706.01	6.01	101.0	28.0	63.00	6	6.30
B1706.02	6.02	101.0	28.0	63.00	6	6.30
B1706.03	6.03	101.0	28.0	63.00	6	6.30
B1706.04	6.04	101.0	28.0	63.00	6	6.30
B1706.05	6.05	101.0	28.0	63.00	6	6.30
B1706.51	6.51	101.0	28.0	63.00	6	6.30
B1706.98	6.98	109.0	31.0	69.00	6	7.10
B1706.99	6.99	109.0	31.0	69.00	6	7.10
B1707.0	7.00	109.0	31.0	69.00	6	7.10
B1707.01	7.01	109.0	31.0	69.00	6	7.10
B1707.02	7.02	109.0	31.0	69.00	6	7.10
B1707.05	7.05	109.0	31.0	69.00	6	7.10
B1707.98	7.98	117.0	33.0	75.00	6	8.00

Product	DC	OAL	LCF	LB	NOF	DCON MS
	(mm)	(mm)	(mm)	(mm)		(mm)
B1707.99	7.99	117.0	33.0	75.00	6	8.00
B1708.0	8.00	117.0	33.0	75.00	6	8.00
B1708.01	8.01	117.0	33.0	75.00	6	8.00
B1708.02	8.02	117.0	33.0	75.00	6	8.00
B1708.03	8.03	117.0	33.0	75.00	6	8.00
B1708.04	8.04	117.0	33.0	75.00	6	8.00
B1708.05	8.05	117.0	33.0	75.00	6	8.00
B1708.98	8.98	125.0	36.0	81.00	6	9.00
B1709.0	9.00	125.0	36.0	81.00	6	9.00
B1709.01	9.01	125.0	36.0	81.00	6	9.00
B1709.02	9.02	125.0	36.0	81.00	6	9.00
B1709.05	9.05	125.0	36.0	81.00	6	9.00
B1709.5	9.50	125.0	36.0	81.00	6	9.00
B1709.51	9.51	133.0	38.0	87.00	6	10.00

Product	DC	OAL	LCF	LB	NOF	DCON MS
	(mm)	(mm)	(mm)	(mm)		(mm)
B1709.52	9.52	133.0	38.0	87.00	6	10.00
B1709.98	9.98	133.0	38.0	87.00	6	10.00
B1709.99	9.99	133.0	38.0	87.00	6	10.00
B17010.0	10.00	133.0	38.0	87.00	6	10.00
B17010.01	10.01	133.0	38.0	87.00	6	10.00
B17010.02	10.02	133.0	38.0	87.00	6	10.00
B17010.03	10.03	133.0	38.0	87.00	6	10.00
B17010.04	10.04	133.0	38.0	87.00	6	10.00
B17010.05	10.05	133.0	38.0	87.00	6	10.00
B17010.98	10.98	142.0	41.0	96.00	6	10.00
B17011.98	11.98	151.0	44.0	105.00	6	10.00
B17011.99	11.99	151.0	44.0	105.00	6	10.00
B17012.0	12.00	151.0	44.0	105.00	6	10.00

B161



Alésoir machine en HSS-E à queue cône morse pour précision H7, finition brillante

Alésoir avec hélice à gauche rectifiée avec précision et action de coupe à droite assurant un alésage en douceur et améliorent l'état de surface et la taille des trous. Convient pour l'alésage dans de nombreux matériaux.

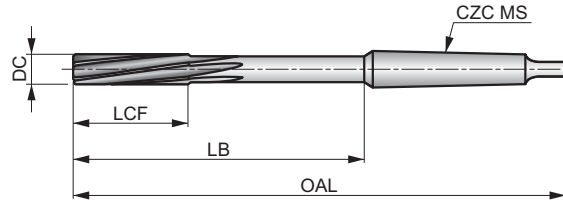

HSS-E	Bright	DIN 208
R		B
H7		

Adéquation du groupe de matériaux de la pièce, valeurs de départ pour la vitesse de coupe (m/min) et code Alpha d'avance. Les tableaux d'avances par tour se trouvent à partir de la page 279.

P1.1 ■ 21 C	P1.2 ■ 24 C	P1.3 ■ 25 C	P2.1 ■ 18 C	P2.2 ■ 16 C	P2.3 ▣ 14 B	P3.1 ■ 13 B	P3.2 ■ 11 B	P3.3 ▣ 9 B	P4.1 ■ 8 B	P4.2 ▣ 7 B	P4.3 ▣ 5 A	M1.1 ▣ 11 C	M1.2 ▣ 10 B
M2.1 ▣ 9 B	K1.1 ■ 16 E	K1.2 ■ 12 D	K1.3 ▣ 9 D	K2.1 ■ 16 C	K2.2 ■ 13 C	K2.3 ▣ 10 C	K3.1 ■ 14 C	K3.2 ▣ 11 C	N1.1 ▣ 24 F	N1.2 ■ 18 F	N1.3 ■ 11 F	N2.1 ▣ 27 E	N2.2 ■ 24 E
N2.3 ■ 16 E	N3.1 ■ 47 D	N3.2 ■ 28 E	N3.3 ▣ 14 D	N4.1 ▣ 30 B									

Product	DC (mm)	OAL (mm)	LCF (mm)	LB (mm)	NOF	CZC MS
B1613.0	3.00	113.0	15.0	47.50	6	MK 1
B1614.0	4.00	124.0	19.0	58.50	6	MK 1
B1615.0	5.00	133.0	23.0	67.50	6	MK 1
B1616.0	6.00	138.0	26.0	72.50	6	MK 1
B1617.0	7.00	150.0	31.0	84.50	6	MK 1
B1618.0	8.00	156.0	33.0	90.50	6	MK 1
B1619.0	9.00	162.0	36.0	96.50	6	MK 1
B16110.0	10.00	168.0	38.0	102.50	6	MK 1
B16111.0	11.00	175.0	41.0	109.50	6	MK 1
B16112.0	12.00	182.0	44.0	116.50	6	MK 1
B16113.0	13.00	182.0	44.0	116.50	6	MK 1
B16114.0	14.00	189.0	47.0	123.50	8	MK 1
B16115.0	15.00	204.0	50.0	124.00	8	MK 2
B16116.0	16.00	210.0	52.0	130.00	8	MK 2
B16117.0	17.00	214.0	54.0	134.00	8	MK 2
B16118.0	18.00	219.0	56.0	139.00	8	MK 2
B16119.0	19.00	223.0	58.0	143.00	8	MK 2
B16120.0	20.00	228.0	60.0	148.00	8	MK 2

Product	DC (mm)	OAL (mm)	LCF (mm)	LB (mm)	NOF	CZC MS
B16121.0	21.00	232.0	62.0	152.00	8	MK 2
B16122.0	22.00	237.0	64.0	157.00	8	MK 2
B16123.0	23.00	241.0	66.0	161.00	8	MK 2
B16124.0	24.00	268.0	68.0	169.00	8	MK 3
B16125.0	25.00	268.0	68.0	169.00	8	MK 3
B16126.0	26.00	273.0	70.0	174.00	8	MK 3
B16127.0	27.00	277.0	71.0	178.00	10	MK 3
B16128.0	28.00	277.0	71.0	178.00	10	MK 3
B16130.0	30.00	281.0	73.0	182.00	10	MK 3
B16132.0	32.00	317.0	77.0	193.00	10	MK 4
B16134.0	34.00	321.0	78.0	197.00	10	MK 4
B16135.0	35.00	321.0	78.0	197.00	10	MK 4
B16138.0	38.00	329.0	81.0	205.00	10	MK 4
B16140.0	40.00	329.0	81.0	205.00	10	MK 4
B16142.0	42.00	333.0	82.0	209.00	12	MK 4
B16145.0	45.00	336.0	83.0	212.00	12	MK 4
B16150.0	50.00	344.0	86.0	220.00	12	MK 4

B101



Alésoir machine en HSS-E à queue cône morse pour précision H7

Alésoir machine à queue cône morse conforme à la norme BS 328. L'hélice à gauche rectifiée avec précision et l'action de coupe à droite assurent un alésage en douceur et améliorent l'état de surface et la taille des trous. Convient pour l'alésage dans de nombreux matériaux.

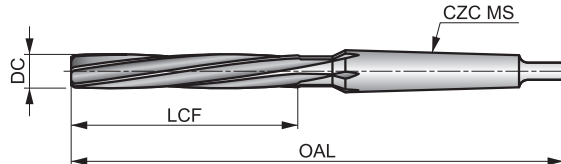

HSS-E	Bright ST	BS 328
R		B
H7		

Adéquation du groupe de matériaux de la pièce, valeurs de départ pour la vitesse de coupe (m/min) et code Alpha d'avance. Les tableaux d'avances par tour se trouvent à partir de la page 279.

P1.1 ■ 15 C	P1.2 ■ 16 C	P1.3 ■ 17 C	P2.1 ■ 13 C	P2.2 ■ 11 C	P2.3 ▣ 10 B	P3.1 ■ 7 B	P3.2 ■ 6 B	P3.3 ▣ 5 B	P4.1 ■ 4 B	P4.2 ▣ 4 B	P4.3 ▣ 3 A	M1.1 ▣ 7 B	M1.2 ▣ 6 A
K1.1 ■ 14 E	K1.2 ■ 10 D	K1.3 ▣ 8 D	K2.1 ■ 12 C	K2.2 ■ 10 C	K2.3 ▣ 8 C	K3.1 ■ 11 C	K3.2 ▣ 8 C	N1.1 ▣ 23 F	N1.2 ■ 17 F	N1.3 ■ 9 F	N2.1 ▣ 25 E	N2.2 ■ 18 E	N2.3 ■ 14 E
N3.1 ■ 34 D	N3.2 ■ 20 E	N3.3 ▣ 10 D	N4.1 ▣ 22 B										

Product	DC (inch)	DC (mm)	OAL (mm)	LCF (mm)	NOF	CZC MS
B1013.0	–	3.00	112.0	33.0	4	MK 1
B1014.0	–	4.00	117.0	38.0	6	MK 1
B1013/16	3/16	4.76	124.0	44.0	6	MK 1
B1015.0	–	5.00	124.0	44.0	6	MK 1
B1016.0	–	6.00	127.0	47.0	6	MK 1
B1011/4	1/4	6.35	130.0	50.0	6	MK 1
B1015/16	5/16	7.94	138.0	58.0	6	MK 1
B1018.0	–	8.00	138.0	58.0	6	MK 1
B1013/8	3/8	9.52	146.0	66.0	6	MK 1
B10110.0	–	10.00	146.0	66.0	6	MK 1
B10111.0	–	11.00	151.0	71.0	6	MK 1
B1017/16	7/16	11.11	151.0	71.0	6	MK 1
B10112.0	–	12.00	156.0	76.0	6	MK 1
B1011/2	1/2	12.70	156.0	76.0	6	MK 1
B10113.0	–	13.00	156.0	76.0	6	MK 1
B10114.0	–	14.00	161.0	81.0	8	MK 1
B1019/16	9/16	14.29	181.0	81.0	8	MK 2
B10115.0	–	15.00	181.0	81.0	8	MK 2
B1015/8	5/8	15.88	187.0	87.0	8	MK 2
B10116.0	–	16.00	187.0	87.0	8	MK 2
B10116.5	–	16.50	187.0	87.0	8	MK 2
B10117.0	–	17.00	187.0	87.0	8	MK 2

Product	DC (inch)	DC (mm)	OAL (mm)	LCF (mm)	NOF	CZC MS
B10118.0	–	18.00	193.0	93.0	8	MK 2
B10119.0	–	19.00	193.0	93.0	8	MK 2
B1013/4	3/4	19.05	200.0	100.0	8	MK 2
B10120.0	–	20.00	200.0	100.0	8	MK 2
B10121.0	–	21.00	200.0	100.0	8	MK 2
B10122.0	–	22.00	207.0	107.0	8	MK 2
B1017/8	7/8	22.22	207.0	107.0	8	MK 2
B10123.0	–	23.00	207.0	107.0	8	MK 2
B10124.0	–	24.00	242.0	115.0	8	MK 3
B10125.0	–	25.00	242.0	115.0	10	MK 3
B1011	1"	25.40	242.0	115.0	10	MK 3
B10126.0	–	26.00	242.0	115.0	10	MK 3
B10128.0	–	28.00	251.0	124.0	10	MK 3
B10129.0	–	29.00	251.0	124.0	10	MK 3
B10130.0	–	30.00	251.0	124.0	10	MK 3
B1011.1/4	1.1/4	31.75	260.0	133.0	10	MK 3
B10135.0	–	35.00	302.0	142.0	10	MK 4
B10140.0	–	40.00	312.0	152.0	10	MK 4
B10141.0	–	41.00	312.0	152.0	10	MK 4
B10144.0	–	44.00	323.0	163.0	10	MK 4
B10150.0	–	50.00	334.0	174.0	12	MK 4

B954

DORMER



Alésoir machine en HSS-E pour goupille conique, à queue cône morse, conicité 1:50

Alésoir avec une coupe douce, une précision et des performances améliorées obtenus grâce au fort angle d'hélice spécialement conçue à gauche et à la coupe à droite. Conçu pour la finition des trous de goupilles coniques métriques standard de rapport 1 à 50. Convient pour l'alésage dans de nombreux matériaux.

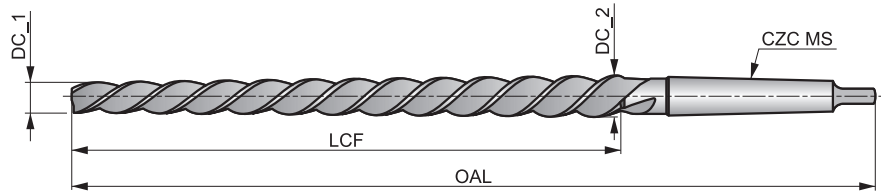

HSS-E	Bright	DIN 2180
R		1:50

Adéquation du groupe de matériaux de la pièce, valeurs de départ pour la vitesse de coupe (m/min) et code Alpha d'avance. Les tableaux d'avances par tour se trouvent à partir de la page 279.

P1.1 ■ 10 B	P1.2 ■ 12 B	P1.3 ■ 13 B	P2.1 ■ 9 B	P2.2 ■ 8 B	P2.3 ▧ 6 A	P3.1 ■ 7 A	P3.2 ■ 6 A	P3.3 ▧ 3 A	P4.1 ■ 4 A	P4.2 ▧ 3 A	P4.3 ▧ 2 A	M1.1 ▧ 11 C	M1.2 ▧ 10 B
M2.1 ▧ 9 B	M2.2 ▧ 8 B	K1.1 ■ 10 C	K1.2 ■ 6 B	K1.3 ▧ 4 B	K2.1 ■ 8 A	K2.2 ■ 6 A	K2.3 ▧ 4 A	K3.1 ■ 11 A	K3.2 ▧ 8 A	N1.1 ▧ 14 F	N1.2 ■ 12 F	N1.3 ■ 9 F	N2.1 ■ 16 E
N2.2 ■ 14 E	N2.3 ▧ 10 E	N3.1 ■ 22 D	N3.2 ■ 14 E	N3.3 ▧ 6 D	N4.1 ▧ 22 B								

Product	nom d	DC_1	DC_2	OAL	LCF	NOF	CZC MS
		(mm)	(mm)	(mm)	(mm)		
B9548.0	8.0	7.90	10.80	227.0	145.0	3	MK 1
B95410.0	10.0	9.90	13.40	257.0	175.0	3	MK 1
B95412.0	12.0	11.80	16.00	315.0	210.0	3	MK 2
B95413.0	13.0	12.86	16.74	295.0	194.0	3	MK 2
B95414.0	14.0	13.86	17.74	295.0	194.0	3	MK 2
B95416.0	16.0	15.80	20.40	335.0	230.0	3	MK 2
B95420.0	20.0	19.80	24.80	377.0	250.0	3	MK 3
B95425.0	25.0	24.70	30.70	427.0	300.0	3	MK 3
B95430.0	30.0	29.70	36.10	475.0	320.0	4	MK 4

B121



Alésoir de chaudronnerie en HSS à queue cône morse

Alésoir conçu pour réaligner les trous dans les grandes fabrications où deux ou plusieurs pièces sont assemblées, avant de les boulonner ou de les riveter. Le petit diamètre pilote de l'entrée conique de rapport 1 à 10 simplifie le repérage et l'alignement de l'outil dans les trous pré-perçés. Convient pour l'alésage dans de nombreux matériaux.

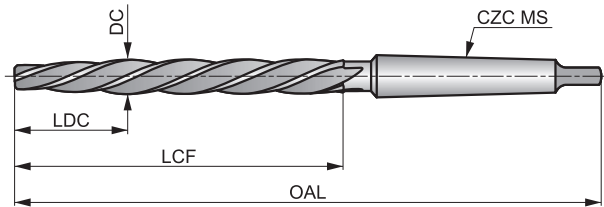

HSS	Bright ST	DIN 311
R		k11

Adéquation du groupe de matériaux de la pièce, valeurs de départ pour la vitesse de coupe (m/min) et code Alpha d'avance. Les tableaux d'avances par tour se trouvent à partir de la page 279.

P1.1 ■ 15 C	P1.2 ■ 16 C	P1.3 ■ 17 C	P2.1 ■ 13 C	P2.2 ■ 11 C	P2.3 ▣ 10 B	P3.1 ■ 7 B	P3.2 ■ 6 B	P3.3 ▣ 5 B	P4.1 ■ 4 B	P4.2 ▣ 4 B	P4.3 ▣ 3 A	K1.1 ■ 14 E	K1.2 ■ 10 D
K1.3 ▣ 8 D	K2.1 ■ 12 C	K2.2 ■ 10 C	K2.3 ▣ 8 C	K3.1 ▣ 11 C	K3.2 ▣ 8 C	N1.1 ▣ 23 F	N1.2 ■ 17 F	N1.3 ■ 9 F	N2.1 ▣ 21 E	N2.2 ■ 18 E	N2.3 ▣ 14 E	N3.1 ■ 34 D	N3.2 ■ 20 E
N3.3 ▣ 10 D	N4.1 ▣ 21 B												

Avec cône d'entrée 1:10 (LDC).

Product	DC (mm)	OAL (mm)	LCF (mm)	LDC (mm)	NOF	CZC MS
B12112.0	12.00	199.0	105.0	39.00	4	MK 2
B12114.0	14.00	209.0	115.0	42.00	4	MK 2
B12116.0	16.00	229.0	135.0	48.00	4	MK 2
B12117.0	17.00	251.0	135.0	51.00	4	MK 3
B12118.0	18.00	261.0	145.0	58.00	4	MK 3
B12120.0	20.00	271.0	155.0	62.00	4	MK 3
B12121.0	21.00	271.0	155.0	62.00	4	MK 3
B12122.0	22.00	281.0	165.0	66.00	4	MK 3
B12124.0	24.00	296.0	180.0	72.00	4	MK 3
B12125.0	25.00	296.0	180.0	72.00	4	MK 3



B640

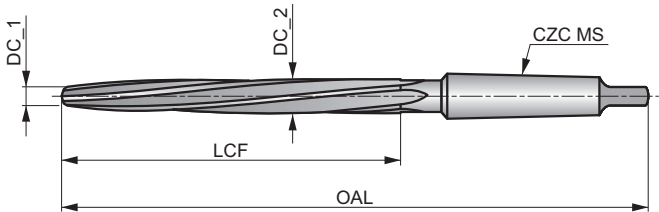

Alésoir en HSS à queue conique, avec traitement vapeur

Utilisé pour réaligner les trous dans les grandes fabrications telles que les poutres en I, lorsque deux pièces ou plus doivent être assemblées par boulonnage ou rivetage. L'extrémité de départ plus petite avec sa longue partie de guidage conique permet à l'opérateur de réaligner les trous mal pré-perçés. Fabriqué conformément à la norme ANSI B94.2-1983 (R1988).



HSS		ANSI
		

Adéquation du groupe de matériaux de la pièce, valeurs de départ pour la vitesse de coupe (m/min) et code Alpha d'avance. Les tableaux d'avances par tour se trouvent à partir de la page 279.

P1.1 ■ 15 C	P1.2 ■ 16 C	P1.3 ■ 17 C	P2.1 ■ 13 C	P2.2 ■ 11 C	P2.3 ■ 10 B	P3.1 ■ 7 B	P3.2 ■ 6 B	P3.3 ■ 5 B	P4.1 ■ 4 B	P4.2 ■ 4 B	P4.3 ■ 3 A	K1.1 ■ 14 E	K1.2 ■ 10 D
K1.3 ■ 8 D	K2.1 ■ 12 C	K2.2 ■ 10 C	K2.3 ■ 8 C	K3.1 ■ 11 C	K3.2 ■ 8 C	N1.1 ■ 23 F	N1.2 ■ 17 F	N1.3 ■ 9 F	N2.1 ■ 21 E	N2.2 ■ 18 E	N2.3 ■ 14 E	N3.1 ■ 34 D	N3.2 ■ 20 E
N3.3 ■ 10 D	N4.1 ■ 21 B												

Product	nom d	DC_1 (inch)	DC_2 (inch)	CZC MS	LCF (inch)	OAL (inch)	NOF
B6407/16	7/16	0.2500	0.4375	2	4.3/8	8.1/4	5
B6401/2	1/2	0.2813	0.5000	2	5.1/8	9"	5
B6409/16	9/16	0.3438	0.5625	2	5.1/8	9"	5
B6405/8	5/8	0.3750	0.6250	2	6.1/8	10"	5
B64011/16	11/16	0.3906	0.6875	3	7.1/8	11.3/4	5
B6403/4	3/4	0.4375	0.7500	3	7.3/8	12"	5
B64013/16	13/16	0.5000	0.8125	3	7.3/8	12"	5
B6407/8	7/8	0.5625	0.8750	3	7.3/8	12"	5
B64015/16	15/16	0.6250	0.9375	3	7.3/8	12"	5
B6401	1"	0.6875	1.0000	3	7.3/8	12"	5
B6401.1/16	1.1/16	0.7500	1.0625	3	7.3/8	12"	5



ISO
13399



PMK
NSH



**OUTILS EN CARBURE MONOBLOC POUR DES PROCESSUS PRODUCTIFS
ET SÉCURISÉS. GÉNÉRALEMENT UTILISÉS AVEC DES MACHINES
À COMMANDE NUMÉRIQUE ET POUR LA FABRICATION AUTOMATISÉE.**

Code de matériau du corps (BMC)	HM	HM	HM	HM															
Groupe standard de base (BSG)																			
Rapport longueur utile diamètre (ULDR)	1×D	1×D	1×D	1×D															
Angle d'application																			
Revêtement																			
Queue																			
Forme de spirale																			
Sens (direction de coupe)																			

Code de famille de produits		R123	R6011	R122	R125														
Plage de diamètres de coupe PSF		5.00 - 20.00	6.00 - 16.00	5.00 - 20.00	5.00 - 16.00														
P	P1	■	■	■	■														
	P2	■	■	■	■														
	P3	■	■	■	■														
	P4	■	■	■	■														
M	M1	■	■	■	■														
	M2	■	■	■	■														
	M3	■	■	■	■														
	M4																		
K	K1	■	■	■	■														
	K2	■	■	■	■														
	K3	■	■	■	■														
	K4	■	■	■	■														
	K5	■	■	■	■														
N	N1	■	■	■	■														
	N2	■	■	■	■														
	N3	■	■	■	■														
	N4	■	■	■	■														
	N5																		
S	S1	■	■	■	■														
	S2	■	■	■	■														
	S3	■	■	■	■														
	S4	■	■	■	■														
H	H1	■	■	■	■														
	H2	▣	▣	▣	▣														
	H3	▣	▣	▣	▣														
	H4																		

R123



Foret à pointer en carbure monobloc, angle de pointe 90°

Foret avec un angle de pointe conçu avec précision pour réaliser un guidage efficace facilitant le centrage du foret dans l'opération suivante. L'angle de pointe à 90° facilite l'auto-centrage et réduit les forces de coupe lors du perçage de nombreux matériaux.

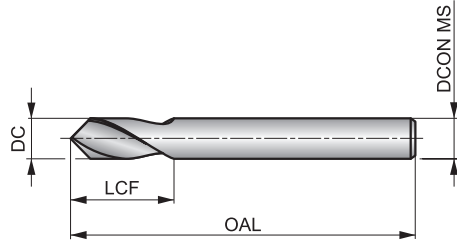

HM		1xD
90°	Bright	
λ 20-35°		DC h6

Adéquation du groupe de matériaux de la pièce, valeurs de départ pour la vitesse de coupe (m/min) et code Alpha d'avance. Les tableaux d'avances par tour se trouvent à partir de la page 274.

P1.1 ■ 99 S	P1.2 ■ 111 S	P1.3 ■ 115 S	P2.1 ■ 85 S	P2.2 ■ 75 S	P2.3 ■ 66 S	P3.1 ■ 66 S	P3.2 ■ 53 S	P3.3 ■ 45 S	P4.1 ■ 40 S	P4.2 ■ 34 S	P4.3 ■ 27 S	M1.1 ■ 73 S	M1.2 ■ 61 S
M2.1 ■ 65 S	M2.2 ■ 53 S	M3.1 ■ 52 S	M3.2 ■ 45 S	K1.1 ■ 75 T	K1.2 ■ 56 T	K1.3 ■ 42 T	K2.1 ■ 68 T	K2.2 ■ 55 T	K2.3 ■ 44 T	K3.1 ■ 60 T	K3.2 ■ 46 T	K3.3 ■ 37 T	K4.1 ■ 55 T
K4.2 ■ 42 T	K4.3 ■ 31 T	K4.4 ■ 26 T	K4.5 ■ 22 T	K5.1 ■ 63 T	K5.2 ■ 47 T	K5.3 ■ 37 T	N1.1 ■ 200 V	N1.2 ■ 150 V	N1.3 ■ 100 V	N2.1 ■ 172 V	N2.2 ■ 155 V	N2.3 ■ 112 V	N3.1 ■ 423 V
N3.2 ■ 250 V	N3.3 ■ 125 V	N4.1 ■ 60 X	N4.2 ■ 100 V	S1.1 ■ 45 T	S1.2 ■ 35 T	S1.3 ■ 25 S	S2.1 ■ 40 S	S2.2 ■ 28 S	S3.1 ■ 30 S	S3.2 ■ 20 S	S4.1 ■ 23 S	S4.2 ■ 16 S	H1.1 ■ 56 S
H2.1 ■ 33 S	H2.2 ■ 36 S	H3.1 ■ 37 S	H3.2 ■ 30 S										

Product	DC	DC	LCF	OAL	DCON MS
	(mm)	(inch)			
R1235.0	5.00	0.1969	16.0	62.0	5.00
R1236.0	6.00	0.2362	17.0	66.0	6.00
R1238.0	8.00	0.3150	22.0	79.0	8.00
R12310.0	10.00	0.3937	26.0	89.0	10.00
R12312.0	12.00	0.4724	30.0	102.0	12.00
R12316.0	16.00	0.6299	34.0	115.0	16.00
R12320.0	20.00	0.7874	40.0	131.0	20.00

R6011



Foret à pointer en carbure monobloc, angle de pointe 90°, revêtement TiAlN

Foret avec un angle de pointe conçu avec précision pour réaliser un guidage efficace facilitant le centrage du foret dans l'opération suivante. L'angle de pointe à 90° facilite l'auto-centrage et réduit les forces de coupe lors du perçage de nombreux matériaux. Son revêtement TiAlN améliore les performances et prolonge la durée de vie de l'outil.

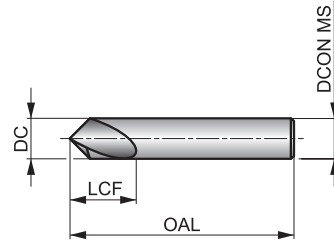

HM		1xD
90°	TiAlN	DIN 6535HA
λ_{20-35°	R	DC h6

Adéquation du groupe de matériaux de la pièce, valeurs de départ pour la vitesse de coupe (m/min) et code Alpha d'avance. Les tableaux d'avances par tour se trouvent à partir de la page 274.

P1.1 ■ 119 S	P1.2 ■ 134 S	P1.3 ■ 138 S	P2.1 ■ 102 S	P2.2 ■ 90 S	P2.3 ■ 80 S	P3.1 ■ 81 S	P3.2 ■ 65 S	P3.3 ■ 55 S	P4.1 ■ 48 S	P4.2 ■ 41 S	P4.3 ■ 34 S	M1.1 ■ 82 S	M1.2 ■ 70 S
M2.1 ■ 73 S	M2.2 ■ 60 S	M3.1 ■ 58 S	M3.2 ■ 50 S	K1.1 ■ 80 T	K1.2 ■ 59 T	K1.3 ■ 44 T	K2.1 ■ 86 T	K2.2 ■ 70 T	K2.3 ■ 56 T	K3.1 ■ 76 T	K3.2 ■ 58 T	K3.3 ■ 47 T	K4.1 ■ 71 T
K4.2 ■ 53 T	K4.3 ■ 39 T	K4.4 ■ 33 T	K4.5 ■ 28 T	K5.1 ■ 80 T	K5.2 ■ 60 T	K5.3 ■ 46 T	N1.1 ■ 200 V	N1.2 ■ 150 V	N1.3 ■ 100 V	N2.1 ■ 172 V	N2.2 ■ 155 V	N2.3 ■ 112 V	N3.1 ■ 423 V
N3.2 ■ 250 V	N3.3 ■ 125 V	N4.1 ■ 60 X	N4.2 ■ 100 V	S1.1 ■ 55 T	S1.2 ■ 45 T	S1.3 ■ 35 S	S2.1 ■ 53 S	S2.2 ■ 42 S	S3.1 ■ 40 S	S3.2 ■ 30 S	S4.1 ■ 31 S	S4.2 ■ 24 S	H1.1 ■ 56 S
H2.1 ■ 33 S	H2.2 ■ 36 S	H3.1 ■ 37 S	H3.2 ■ 30 S										

DCON MS tolérance h6.

Product	DC	DC	LCF	OAL	DCON MS
	(mm)	(inch)			
R60116.0	6.00	0.2362	16.0	50.0	6.00
R601110.0	10.00	0.3937	25.0	70.0	10.00
R601116.0	16.00	0.6299	26.0	90.0	16.00

R122



Foret à pointer en carbure monobloc, angle de pointe 120°

Foret avec un angle de pointe conçu avec précision pour réaliser un guidage efficace facilitant le centrage du foret dans l'opération suivante. L'angle de pointe à 120° facilite l'auto-centrage et réduit les forces de coupe lors du perçage de nombreux matériaux.

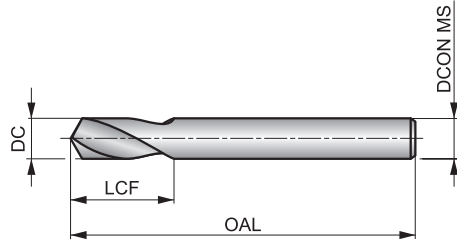

HM		1xD
120°	Bright	
λ 20-35°		DC h6

Adéquation du groupe de matériaux de la pièce, valeurs de départ pour la vitesse de coupe (m/min) et code Alpha d'avance. Les tableaux d'avances par tour se trouvent à partir de la page 274.

P1.1 ■ 99 S	P1.2 ■ 111 S	P1.3 ■ 115 S	P2.1 ■ 85 S	P2.2 ■ 75 S	P2.3 ■ 66 S	P3.1 ■ 66 S	P3.2 ■ 53 S	P3.3 ■ 45 S	P4.1 ■ 40 S	P4.2 ■ 34 S	P4.3 ■ 27 S	M1.1 ■ 73 S	M1.2 ■ 61 S
M2.1 ■ 65 S	M2.2 ■ 53 S	M3.1 ■ 52 S	M3.2 ■ 45 S	K1.1 ■ 75 T	K1.2 ■ 56 T	K1.3 ■ 42 T	K2.1 ■ 68 T	K2.2 ■ 55 T	K2.3 ■ 44 T	K3.1 ■ 60 T	K3.2 ■ 46 T	K3.3 ■ 37 T	K4.1 ■ 55 T
K4.2 ■ 42 T	K4.3 ■ 31 T	K4.4 ■ 26 T	K4.5 ■ 22 T	K5.1 ■ 63 T	K5.2 ■ 47 T	K5.3 ■ 37 T	N1.1 ■ 200 V	N1.2 ■ 150 V	N1.3 ■ 100 V	N2.1 ■ 172 V	N2.2 ■ 155 V	N2.3 ■ 112 V	N3.1 ■ 423 V
N3.2 ■ 250 V	N3.3 ■ 125 V	N4.1 ■ 60 X	N4.2 ■ 100 V	S1.1 ■ 45 T	S1.2 ■ 35 T	S1.3 ■ 25 S	S2.1 ■ 40 S	S2.2 ■ 28 S	S3.1 ■ 30 S	S3.2 ■ 20 S	S4.1 ■ 23 S	S4.2 ■ 16 S	H1.1 ■ 56 S
H2.1 ■ 33 S	H2.2 ■ 36 S	H3.1 ■ 37 S	H3.2 ■ 30 S										

Product	DC	DC	LCF	OAL	DCON MS
	(mm)	(inch)			
R1225.0	5.00	0.1969	16.0	62.0	5.00
R1226.0	6.00	0.2362	17.0	66.0	6.00
R1228.0	8.00	0.3150	22.0	79.0	8.00
R12210.0	10.00	0.3937	26.0	89.0	10.00
R12212.0	12.00	0.4724	30.0	102.0	12.00
R12216.0	16.00	0.6299	34.0	115.0	16.00
R12220.0	20.00	0.7874	40.0	131.0	20.00

R125

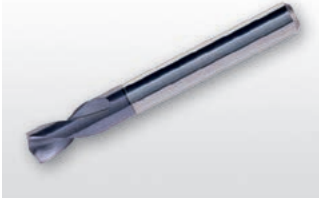

Foret à pointer en carbure monobloc, angle de pointe 150°, revêtement TiAlN

Foret avec un angle de pointe conçu avec précision pour réaliser un guidage efficace facilitant le centrage du foret dans l'opération suivante. L'angle de pointe à 150° facilite l'auto-centrage et réduit les forces de coupe lors du perçage de nombreux matériaux. Son revêtement TiAlN améliore les performances et prolonge la durée de vie de l'outil.

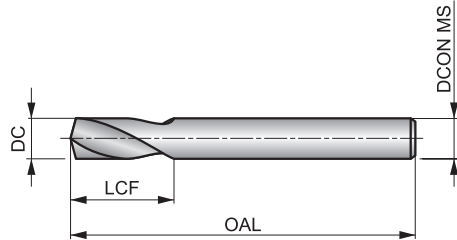

HM	DORMER	1xD
150°	TiAlN	
λ 20-35°	R	DC h6

Adéquation du groupe de matériaux de la pièce, valeurs de départ pour la vitesse de coupe (m/min) et code Alpha d'avance. Les tableaux d'avances par tour se trouvent à partir de la page 274.

P1.1 ■ 119 S	P1.2 ■ 134 S	P1.3 ■ 138 S	P2.1 ■ 102 S	P2.2 ■ 90 S	P2.3 ■ 80 S	P3.1 ■ 81 S	P3.2 ■ 65 S	P3.3 ■ 55 S	P4.1 ■ 48 S	P4.2 ■ 41 S	P4.3 ■ 34 S	M1.1 ■ 82 S	M1.2 ■ 70 S
M2.1 ■ 73 S	M2.2 ■ 60 S	M3.1 ■ 58 S	M3.2 ■ 50 S	K1.1 ■ 80 T	K1.2 ■ 59 T	K1.3 ■ 44 T	K2.1 ■ 86 T	K2.2 ■ 70 T	K2.3 ■ 56 T	K3.1 ■ 76 T	K3.2 ■ 58 T	K3.3 ■ 47 T	K4.1 ■ 71 T
K4.2 ■ 53 T	K4.3 ■ 39 T	K4.4 ■ 33 T	K4.5 ■ 28 T	K5.1 ■ 80 T	K5.2 ■ 60 T	K5.3 ■ 46 T	N1.1 ■ 200 V	N1.2 ■ 150 V	N1.3 ■ 100 V	N2.1 ■ 172 V	N2.2 ■ 155 V	N2.3 ■ 112 V	N3.1 ■ 423 V
N3.2 ■ 250 V	N3.3 ■ 125 V	N4.1 ■ 60 X	N4.2 ■ 100 V	S1.1 ■ 55 T	S1.2 ■ 45 T	S1.3 ■ 35 S	S2.1 ■ 53 S	S2.2 ■ 42 S	S3.1 ■ 40 S	S3.2 ■ 30 S	S4.1 ■ 31 S	S4.2 ■ 24 S	H1.1 ■ 56 S
H2.1 ■ 33 S	H2.2 ■ 36 S	H3.1 ■ 37 S	H3.2 ■ 30 S										

DCON MS tolérance h6.

Product	DC (mm)	LCF (mm)	OAL (mm)	DCON MS (mm)
R1255.0	5.00	16.0	62.0	5.00
R1256.0	6.00	17.0	66.0	6.00
R1258.0	8.00	22.0	79.0	8.00
R12510.0	10.00	26.0	89.0	10.00
R12512.0	12.00	30.0	102.0	12.00
R12516.0	16.00	34.0	115.0	16.00

Code de matériau du corps (BMC)	HM	HM	HM	HM	HM	HM	HM	HM	HM	HM									
Groupe standard de base (BSG)	DIN 6539	DIN 338	DIN 6537K	DIN 6537K	DIN 6537L	DIN 6537L	DORMER	DIN 6537K	DIN 6537L	DORMER									
Rapport longueur utile diamètre (ULDR)	2.5xD	4xD	3xD	3xD	5xD	5xD	8xD	3xD	5xD	3xD									
Angle d'application	130°	130°	140°	140°	140°	140°	140°	140°	140°	140°									
Revêtement	TiN	TiN	TiAlN	TiAlN	TiAlN	TiAlN	TiAlN	TiAlN	TiAlN	TiAlN									
Queue			DIN 6535HA	DIN 6535HA	DIN 6535HA	DIN 6535HA	DIN 6535HA	DIN 6535HA	DIN 6535HA	DIN 6535HA									
Forme de spirale	λ 20-35°	λ 20-35°	CTW	CTW	CTW	CTW	CTW	CTW	CTW	CTW									
Sens (direction de coupe)	R	R	R	R	R	R	R	R	R	R									
Propriété d'alimentation en liquide de coupe (CSP)																			
	CDX	CDX	FORCE X	FORCE X	FORCE X	FORCE X	FORCE X	FORCE X	FORCE M	FORCE M									

Code de famille de produits	R520	R510	R458	R457	R454	R453	R459	R467	R463	R7131									
Plage de diamètres de coupe PSF	3.00 - 16.50	3.00 - 14.00	3.00 - 20.00	3.00 - 20.00	3.00 - 20.00	3.00 - 20.00	3.00 - 16.00	3.00 - 16.00	3.00 - 16.00	3.30 - 10.40									
	188	190	191	195	199	203	207	210	213	216									

P	P1	■	■	■	■	■	■	■	■	■									
	P2	■	■	■	■	■	■	■	■	■									
	P3	■	■	■	■	■	■	■	■	■									
	P4	■	■	■	■	■	■	■	■	■									
M	M1	■	■	■	■	■	■	■	■	■									
	M2	■	■	■	■	■	■	■	■	■									
	M3			■	■	■	■	■	■	■									
	M4			■	■	■	■	■	■	■									
K	K1	■	■	■	■	■	■	■	■	■									
	K2	■	■	■	■	■	■	■	■	■									
	K3	■	■	■	■	■	■	■	■	■									
	K4	■	■	■	■	■	■	■	■	■									
	K5	■	■	■	■	■	■	■	■	■									
N	N1	■	■	■	■	■	■	■	■	■									
	N2	■	■	■	■	■	■	■	■	■									
	N3			■	■	■	■	■	■	■									
	N4	■	■																
	N5																		
S	S1	■	■	■	■	■	■	■	■	■									
	S2																		
	S3																		
	S4																		
H	H1	■	■	■	■	■	■	■	■	■									
	H2	■	■	■	■	■	■	■	■	■									
	H3	■	■	■	■	■	■	■	■	■									
	H4																		



R520



Foret carbure monobloc CDX longueur 2,5xD, revêtement TiN

Foret court haute performance capable de produire des trous précis de haute qualité à des vitesses et des avances élevées (tolérance de trou H8). L'angle de pointe à 130° favorise l'auto-centrage et réduit les efforts de coupe. Le revêtement TiN améliore les performances et prolonge la durée de vie de l'outil. Convient à toutes les machines CNC et à de nombreux matériaux.

CDX

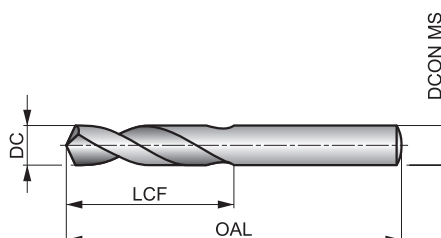

HM	DIN 6539	2.5xD
130°	TiN	
λ 20-35°	R	DC h7

Adéquation du groupe de matériaux de la pièce, valeurs de départ pour la vitesse de coupe (m/min) et code Alpha d'avance. Les tableaux d'avances par tour se trouvent à partir de la page 274.

P1.1 ■ 119 X	P1.2 ■ 134 X	P1.3 ■ 138 X	P2.1 ■ 102 X	P2.2 ■ 90 X	P2.3 ■ 80 X	P3.1 ■ 81 X	P3.2 ■ 65 X	P3.3 ■ 55 X	P4.1 ■ 48 X	P4.2 ■ 41 X	P4.3 ■ 34 W	M1.1 ■ 69 W	M1.2 ■ 58 W
M2.1 ■ 61 W	M2.2 ■ 50 W	K1.1 ■ 90 Y	K1.2 ■ 67 Y	K1.3 ■ 50 Y	K2.1 ■ 80 X	K2.2 ■ 65 X	K2.3 ■ 52 X	K3.1 ■ 71 X	K3.2 ■ 54 X	K3.3 ■ 44 X	K4.1 ■ 66 X	K4.2 ■ 49 X	K4.3 ■ 36 X
K4.4 ■ 31 X	K4.5 ■ 26 X	K5.1 ■ 74 X	K5.2 ■ 56 X	K5.3 ■ 43 X	N1.1 ■ 225 Z	N1.2 ■ 169 Z	N1.3 ■ 113 Z	N2.1 ■ 231 Y	N2.2 ■ 208 Y	N2.3 ■ 150 Y	N4.1 ■ 75 Z	N4.2 ■ 115 V	S1.1 ■ 60 W
S1.2 ■ 45 V	S1.3 ■ 35 U	H1.1 ■ 65 U	H2.1 ■ 38 U	H2.2 ■ 36 T	H3.1 ■ 43 U	H3.2 ■ 35 U							

DCON MS tolérance h7.

Product	DC (inch)	DC (mm)	DC (inch)	LCF (mm)	OAL (mm)	DCON MS (mm)
R5203.0	–	3.00	0.1181	16.0	46.0	3.00
R5203.1	–	3.10	0.1220	18.0	49.0	3.10
R5201/8	1/8	3.18	0.1250	18.0	49.0	3.18
R5203.2	–	3.20	0.1260	18.0	49.0	3.20
R5203.3	–	3.30	0.1299	18.0	49.0	3.30
R5203.4	–	3.40	0.1339	20.0	52.0	3.40
R5203.5	–	3.50	0.1378	20.0	52.0	3.50
R5203.6	–	3.60	0.1417	20.0	52.0	3.60
R5203.7	–	3.70	0.1457	20.0	52.0	3.70
R5203.8	–	3.80	0.1496	22.0	55.0	3.80
R5203.9	–	3.90	0.1535	22.0	55.0	3.90
R5204.0	–	4.00	0.1575	22.0	55.0	4.00
R5204.1	–	4.10	0.1614	22.0	55.0	4.10
R5204.2	–	4.20	0.1654	22.0	55.0	4.20
R5204.3	–	4.30	0.1693	24.0	58.0	4.30
R5204.4	–	4.40	0.1732	24.0	58.0	4.40
R5204.5	–	4.50	0.1772	24.0	58.0	4.50
R5204.6	–	4.60	0.1811	24.0	58.0	4.60
R5204.7	–	4.70	0.1850	24.0	58.0	4.70
R5204.8	–	4.80	0.1890	26.0	62.0	4.80
R5204.9	–	4.90	0.1929	26.0	62.0	4.90
R5205.0	–	5.00	0.1969	26.0	62.0	5.00
R5205.1	–	5.10	0.2008	26.0	62.0	5.10
R5205.2	–	5.20	0.2047	26.0	62.0	5.20
R5205.3	–	5.30	0.2087	26.0	62.0	5.30

Product	DC (inch)	DC (mm)	DC (inch)	LCF (mm)	OAL (mm)	DCON MS (mm)
R5205.4	–	5.40	0.2126	28.0	66.0	5.40
R5205.5	–	5.50	0.2165	28.0	66.0	5.50
R5205.6	–	5.60	0.2205	28.0	66.0	5.60
R5205.8	–	5.80	0.2283	28.0	66.0	5.80
R5205.9	–	5.90	0.2323	28.0	66.0	5.90
R5206.0	–	6.00	0.2362	28.0	66.0	6.00
R5206.1	–	6.10	0.2402	31.0	70.0	6.10
R5206.2	–	6.20	0.2441	31.0	70.0	6.20
R5206.3	–	6.30	0.2480	31.0	70.0	6.30
R5201/4	1/4	6.35	0.2500	31.0	70.0	6.35
R5206.4	–	6.40	0.2520	31.0	70.0	6.40
R5206.5	–	6.50	0.2559	31.0	70.0	6.50
R5206.6	–	6.60	0.2598	31.0	70.0	6.60
R5206.7	–	6.70	0.2638	31.0	70.0	6.70
R5206.8	–	6.80	0.2677	34.0	74.0	6.80
R5206.9	–	6.90	0.2717	34.0	74.0	6.90
R5207.0	–	7.00	0.2756	34.0	74.0	7.00
R5207.1	–	7.10	0.2795	34.0	74.0	7.10
R5207.2	–	7.20	0.2835	34.0	74.0	7.20
R5207.3	–	7.30	0.2874	34.0	74.0	7.30
R5207.4	–	7.40	0.2913	34.0	74.0	7.40
R5207.5	–	7.50	0.2953	34.0	74.0	7.50
R5207.6	–	7.60	0.2992	37.0	79.0	7.60
R5207.7	–	7.70	0.3031	37.0	79.0	7.70
R5207.8	–	7.80	0.3071	37.0	79.0	7.80



Product	DC	DC	DC	LCF	OAL	D CON MS
	(inch)	(mm)	(inch)	(mm)	(mm)	(mm)
R5205/16	5/16	7.94	0.3126	37.0	79.0	7.94
R5208.0	–	8.00	0.3150	37.0	79.0	8.00
R5208.1	–	8.10	0.3189	37.0	79.0	8.10
R5208.2	–	8.20	0.3228	37.0	79.0	8.20
R5208.3	–	8.30	0.3268	37.0	79.0	8.30
R5208.4	–	8.40	0.3307	37.0	79.0	8.40
R5208.5	–	8.50	0.3346	37.0	79.0	8.50
R5208.6	–	8.60	0.3386	40.0	84.0	8.60
R5208.7	–	8.70	0.3425	40.0	84.0	8.70
R5208.8	–	8.80	0.3465	40.0	84.0	8.80
R5209.0	–	9.00	0.3543	40.0	84.0	9.00
R5209.1	–	9.10	0.3583	40.0	84.0	9.10
R5209.3	–	9.30	0.3661	40.0	84.0	9.30
R5209.5	–	9.50	0.3740	40.0	84.0	9.50
R5203/8	3/8	9.52	0.3748	43.0	89.0	9.52
R5209.6	–	9.60	0.3780	43.0	89.0	9.60
R5209.7	–	9.70	0.3819	43.0	89.0	9.70
R5209.8	–	9.80	0.3858	43.0	89.0	9.80
R52010.0	–	10.00	0.3937	43.0	89.0	10.00
R52010.1	–	10.10	0.3976	43.0	89.0	10.10
R52010.2	–	10.20	0.4016	43.0	89.0	10.20

Product	DC	DC	DC	LCF	OAL	D CON MS
	(inch)	(mm)	(inch)	(mm)	(mm)	(mm)
R52010.3	–	10.30	0.4055	43.0	89.0	10.30
R52010.4	–	10.40	0.4094	43.0	89.0	10.40
R52010.5	–	10.50	0.4134	43.0	89.0	10.50
R52011.0	–	11.00	0.4331	47.0	95.0	11.00
R5207/16	7/16	11.11	0.4374	47.0	95.0	11.11
R52011.2	–	11.20	0.4409	47.0	95.0	11.20
R52011.5	–	11.50	0.4528	47.0	95.0	11.50
R52012.0	–	12.00	0.4724	51.0	102.0	12.00
R52012.5	–	12.50	0.4921	51.0	102.0	12.50
R5201/2	1/2	12.70	0.5000	51.0	102.0	12.70
R52013.0	–	13.00	0.5118	51.0	102.0	13.00
R52013.5	–	13.50	0.5315	54.0	107.0	13.50
R52014.0	–	14.00	0.5512	54.0	107.0	14.00
R52014.2	–	14.20	0.5591	56.0	111.0	14.20
R52014.25	–	14.25	0.5610	56.0	111.0	14.25
R52014.5	–	14.50	0.5709	56.0	111.0	14.50
R52015.0	–	15.00	0.5906	56.0	111.0	15.00
R52015.1	–	15.10	0.5945	58.0	115.0	15.10
R5205/8	5/8	15.88	0.6252	58.0	115.0	15.88
R52016.0	–	16.00	0.6299	58.0	115.0	16.00
R52016.5	–	16.50	0.6496	60.0	119.0	16.50

R510



Foret carbure monobloc CDX longueur 4xD, revêtement TiN

Foret haute performance capable de produire des trous précis de haute qualité à des vitesses et des avances élevées (tolérance de trou H8). La pointe à 130° favorise l'auto-centrage et réduit les efforts de coupe. Le revêtement TiN améliore les performances et prolonge la durée de vie de l'outil. Convient à toutes les machines CNC et dans de nombreux matériaux.

CDX

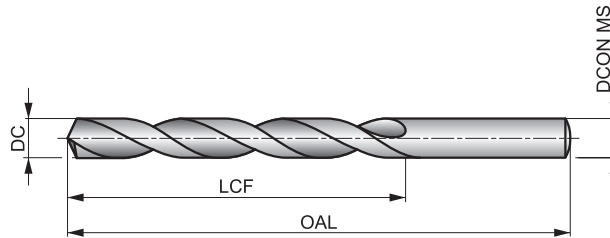

HM	DIN 338	4xD
130°	TiN	
λ 20-35°	R	DC h7

Adéquation du groupe de matériaux de la pièce, valeurs de départ pour la vitesse de coupe (m/min) et code Alpha d'avance. Les tableaux d'avances par tour se trouvent à partir de la page 274.

P1.1 ■ 119 W	P1.2 ■ 134 W	P1.3 ■ 138 W	P2.1 ■ 102 W	P2.2 ■ 90 W	P2.3 ■ 80 V	P3.1 ■ 81 W	P3.2 ■ 65 W	P3.3 ■ 55 V	P4.1 ■ 48 W	P4.2 ■ 41 V	P4.3 ■ 34 V	M1.1 ■ 69 V	M1.2 ■ 58 V
M2.1 ■ 61 V	M2.2 ■ 50 V	K1.1 ■ 90 X	K1.2 ■ 67 X	K1.3 ■ 50 X	K2.1 ■ 80 W	K2.2 ■ 65 W	K2.3 ■ 52 W	K3.1 ■ 71 W	K3.2 ■ 54 W	K3.3 ■ 44 W	K4.1 ■ 66 W	K4.2 ■ 49 W	K4.3 ■ 36 W
K4.4 ■ 31 W	K4.5 ■ 26 W	K5.1 ■ 74 W	K5.2 ■ 56 W	K5.3 ■ 43 W	N1.1 ■ 225 Y	N1.2 ■ 169 Y	N1.3 ■ 113 Y	N2.1 ■ 231 X	N2.2 ■ 208 X	N2.3 ■ 150 X	N4.1 ■ 75 X	N4.2 ■ 115 V	S1.1 ■ 45 V
H1.1 ■ 65 T	H2.1 ■ 38 T	H2.2 ■ 36 S	H3.1 ■ 43 T	H3.2 ■ 35 T									

DCON MS tolérance h7.

Product	DC (inch)	DC (mm)	DC (inch)	LCF (mm)	OAL (mm)	DCON MS (mm)
R5103.0	–	3.00	0.1181	33.0	61.0	3.00
R5101/8	1/8	3.18	0.1250	36.0	65.0	3.18
R5103.2	–	3.20	0.1260	36.0	65.0	3.20
R5103.3	–	3.30	0.1299	36.0	65.0	3.30
R5103.4	–	3.40	0.1339	39.0	70.0	3.40
R5103.5	–	3.50	0.1378	39.0	70.0	3.50
R5103.7	–	3.70	0.1457	39.0	70.0	3.70
R5103.9	–	3.90	0.1535	43.0	75.0	3.90
R5104.0	–	4.00	0.1575	43.0	75.0	4.00
R5104.1	–	4.10	0.1614	43.0	75.0	4.10
R5104.2	–	4.20	0.1654	43.0	75.0	4.20
R5104.3	–	4.30	0.1693	47.0	80.0	4.30
R5104.5	–	4.50	0.1772	47.0	80.0	4.50
R5104.7	–	4.70	0.1850	47.0	80.0	4.70
R5103/16	3/16	4.76	0.1874	52.0	86.0	4.76
R5104.9	–	4.90	0.1929	52.0	86.0	4.90
R5105.0	–	5.00	0.1969	52.0	86.0	5.00
R5105.1	–	5.10	0.2008	52.0	86.0	5.10
R5105.5	–	5.50	0.2165	57.0	93.0	5.50
R5105.6	–	5.60	0.2205	57.0	93.0	5.60
R5105.7	–	5.70	0.2244	57.0	93.0	5.70
R5106.0	–	6.00	0.2362	57.0	93.0	6.00
R5101/4	1/4	6.35	0.2500	63.0	101.0	6.35
R5106.5	–	6.50	0.2559	63.0	101.0	6.50
R5106.6	–	6.60	0.2598	63.0	101.0	6.60
R5106.8	–	6.80	0.2677	69.0	109.0	6.80
R5107.0	–	7.00	0.2756	69.0	109.0	7.00
R5107.3	–	7.30	0.2874	69.0	109.0	7.30

Product	DC (inch)	DC (mm)	DC (inch)	LCF (mm)	OAL (mm)	DCON MS (mm)
R5107.4	–	7.40	0.2913	69.0	109.0	7.40
R5107.5	–	7.50	0.2953	69.0	109.0	7.50
R5107.8	–	7.80	0.3071	75.0	117.0	7.80
R5105/16	5/16	7.94	0.3126	75.0	117.0	7.94
R5108.0	–	8.00	0.3150	75.0	117.0	8.00
R5108.5	–	8.50	0.3346	75.0	117.0	8.50
R5108.7	–	8.70	0.3425	81.0	125.0	8.70
R5108.8	–	8.80	0.3465	81.0	125.0	8.80
R5109.0	–	9.00	0.3543	81.0	125.0	9.00
R5109.2	–	9.20	0.3622	81.0	125.0	9.20
R5109.3	–	9.30	0.3661	81.0	125.0	9.30
R5109.5	–	9.50	0.3740	81.0	125.0	9.50
R5103/8	3/8	9.52	0.3748	87.0	133.0	9.52
R5109.9	–	9.90	0.3898	87.0	133.0	9.90
R51010.0	–	10.00	0.3937	87.0	133.0	10.00
R51010.2	–	10.20	0.4016	87.0	133.0	10.20
R51010.3	–	10.30	0.4055	87.0	133.0	10.30
R51010.4	–	10.40	0.4094	87.0	133.0	10.40
R51010.5	–	10.50	0.4134	87.0	133.0	10.50
R51010.8	–	10.80	0.4252	94.0	142.0	10.80
R51011.0	–	11.00	0.4331	94.0	142.0	11.00
R5107/16	7/16	11.11	0.4374	94.0	142.0	11.11
R51011.2	–	11.20	0.4409	94.0	142.0	11.20
R51011.5	–	11.50	0.4528	94.0	142.0	11.50
R51012.0	–	12.00	0.4724	101.0	151.0	12.00
R5101/2	1/2	12.70	0.5000	101.0	151.0	12.70
R51013.0	–	13.00	0.5118	101.0	151.0	13.00
R51014.0	–	14.00	0.5512	108.0	160.0	14.00

R458



Foret carbure monobloc FORCE X longueur 3xD, revêtement TiAlN

Foret haute performance multi-applications capable de produire des trous précis de haute qualité à des vitesses et des avances élevées (tolérance de trou H9). Pointe auto-centrante à 140° avec 4 facettes et une conception de goujure CTW pour un débit copeaux optimum. Le revêtement TiAlN augmente la dureté en surface et améliore la durée de vie de l'outil.

FORCE X

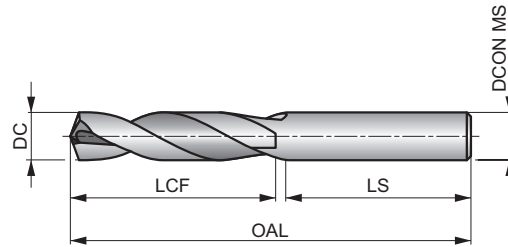

HM	DIN 6537K	3xD
140°	TiAlN	DIN 6535HA
CTW	R	DC m7

Adéquation du groupe de matériaux de la pièce, valeurs de départ pour la vitesse de coupe (m/min) et code Alpha d'avance. Les tableaux d'avances par tour se trouvent à partir de la page 274.

P1.1 ■ 143 W	P1.2 ■ 160 W	P1.3 ■ 166 W	P2.1 ■ 122 W	P2.2 ■ 108 W	P2.3 ■ 95 V	P3.1 ■ 106 V	P3.2 ■ 86 V	P3.3 ■ 72 V	P4.1 ■ 63 V	P4.2 ■ 54 V	P4.3 ■ 44 U	M1.1 □ 60 U	M1.2 □ 51 U
M2.1 □ 54 U	M2.2 □ 44 U	M2.3 □ 37 T	M3.1 □ 33 T	M3.2 □ 28 T	M3.3 □ 26 T	M4.1 □ 24 T	M4.2 □ 21 T	K1.1 ■ 88 W	K1.2 ■ 65 W	K1.3 ■ 49 W	K2.1 ■ 78 V	K2.2 ■ 64 V	K2.3 ■ 51 V
K3.1 ■ 70 V	K3.2 ■ 54 V	K3.3 ■ 43 V	K4.1 ■ 65 V	K4.2 ■ 49 V	K4.3 ■ 36 V	K4.4 ■ 30 V	K4.5 ■ 26 V	K5.1 ■ 73 V	K5.2 ■ 55 V	K5.3 ■ 42 V	N1.1 ■ 200 W	N1.2 ■ 150 W	N1.3 ■ 100 W
N2.1 ■ 246 V	N2.2 ■ 222 V	N2.3 ■ 160 V	N3.1 ■ 298 V	N3.2 ■ 176 V	N3.3 ■ 88 V	S1.1 □ 44 U	S1.2 □ 36 U	S1.3 □ 32 T	H1.1 ■ 45 U	H2.1 □ 26 U	H2.2 □ 24 U	H3.1 □ 30 U	H3.2 □ 24 U

DCON MS tolérance h6.

Product	DC (inch)	DC (mm)	DC (inch)	LCF (mm)	OAL (mm)	LS (mm)	DCON MS (mm)
R4583.0	–	3.00	0.1181	20.0	62.0	36.0	6.00
R4583.1	–	3.10	0.1220	20.0	62.0	36.0	6.00
R4581/8	1/8	3.18	0.1250	20.0	62.0	36.0	6.00
R4583.2	–	3.20	0.1260	20.0	62.0	36.0	6.00
R458N30	N30	3.26	0.1283	20.0	62.0	36.0	6.00
R4583.3	–	3.30	0.1299	20.0	62.0	36.0	6.00
R4583.4	–	3.40	0.1339	20.0	62.0	36.0	6.00
R458N29	N29	3.45	0.1360	20.0	62.0	36.0	6.00
R4583.5	–	3.50	0.1378	20.0	62.0	36.0	6.00
R458N28	N28	3.57	0.1406	20.0	62.0	36.0	6.00
R4589/64	9/64	3.57	0.1406	20.0	62.0	36.0	6.00
R4583.6	–	3.60	0.1417	20.0	62.0	36.0	6.00
R458N27	N27	3.66	0.1441	20.0	62.0	36.0	6.00
R4583.7	–	3.70	0.1457	20.0	62.0	36.0	6.00
R4583.73	–	3.73	0.1469	24.0	66.0	36.0	6.00
R458N26	N26	3.73	0.1469	24.0	66.0	36.0	6.00
R458N25	N25	3.80	0.1496	24.0	66.0	36.0	6.00
R4583.8	–	3.80	0.1496	24.0	66.0	36.0	6.00
R458N24	N24	3.86	0.1520	24.0	66.0	36.0	6.00
R4583.9	–	3.90	0.1535	24.0	66.0	36.0	6.00
R458N23	N23	3.91	0.1539	24.0	66.0	36.0	6.00
R4585/32	5/32	3.97	0.1563	24.0	66.0	36.0	6.00
R458N22	N22	3.99	0.1571	24.0	66.0	36.0	6.00
R4584.0	–	4.00	0.1575	24.0	66.0	36.0	6.00
R458N21	N21	4.04	0.1591	24.0	66.0	36.0	6.00

Product	DC	DC	DC	LCF	OAL	LS	DCON MS
	(inch)	(mm)	(inch)	(mm)	(mm)	(mm)	(mm)
R458N20	N20	4.09	0.1610	24.0	66.0	36.0	6.00
R4584.1	–	4.10	0.1614	24.0	66.0	36.0	6.00
R4584.2	–	4.20	0.1654	24.0	66.0	36.0	6.00
R458N19	N19	4.22	0.1661	24.0	66.0	36.0	6.00
R4584.3	–	4.30	0.1693	24.0	66.0	36.0	6.00
R458N18	N18	4.31	0.1697	24.0	66.0	36.0	6.00
R45811/64	11/64	4.37	0.1719	24.0	66.0	36.0	6.00
R458N17	N17	4.39	0.1728	24.0	66.0	36.0	6.00
R4584.4	–	4.40	0.1732	24.0	66.0	36.0	6.00
R4584.5	–	4.50	0.1772	24.0	66.0	36.0	6.00
R458N16	N16	4.50	0.1772	24.0	66.0	36.0	6.00
R458N15	N15	4.57	0.1799	24.0	66.0	36.0	6.00
R4584.6	–	4.60	0.1811	24.0	66.0	36.0	6.00
R458N14	N14	4.62	0.1819	24.0	66.0	36.0	6.00
R458N13	N13	4.70	0.1850	24.0	66.0	36.0	6.00
R4584.7	–	4.70	0.1850	24.0	66.0	36.0	6.00
R4583/16	3/16	4.76	0.1875	28.0	66.0	36.0	6.00
R4584.8	–	4.80	0.1890	28.0	66.0	36.0	6.00
R458N12	N12	4.80	0.1890	28.0	66.0	36.0	6.00
R458N11	N11	4.85	0.1909	28.0	66.0	36.0	6.00
R4584.9	–	4.90	0.1929	28.0	66.0	36.0	6.00
R458N10	N10	4.92	0.1937	28.0	66.0	36.0	6.00
R458N9	N9	4.98	0.1961	28.0	66.0	36.0	6.00
R4585.0	–	5.00	0.1969	28.0	66.0	36.0	6.00
R458N8	N8	5.06	0.1992	28.0	66.0	36.0	6.00
R4585.1	–	5.10	0.2008	28.0	66.0	36.0	6.00
R458N7	N7	5.11	0.2010	28.0	66.0	36.0	6.00
R45813/64	13/64	5.16	0.2031	28.0	66.0	36.0	6.00
R458N6	N6	5.18	0.2039	28.0	66.0	36.0	6.00
R4585.2	–	5.20	0.2047	28.0	66.0	36.0	6.00
R458N5	N5	5.22	0.2055	28.0	66.0	36.0	6.00
R4585.3	–	5.30	0.2087	28.0	66.0	36.0	6.00
R458N4	N4	5.31	0.2091	28.0	66.0	36.0	6.00
R4585.4	–	5.40	0.2126	28.0	66.0	36.0	6.00
R458N3	N3	5.41	0.2130	28.0	66.0	36.0	6.00
R4585.5	–	5.50	0.2165	28.0	66.0	36.0	6.00
R4587/32	7/32	5.56	0.2188	28.0	66.0	36.0	6.00
R4585.6	–	5.60	0.2205	28.0	66.0	36.0	6.00
R458N2	N2	5.61	0.2209	28.0	66.0	36.0	6.00
R4585.7	–	5.70	0.2244	28.0	66.0	36.0	6.00
R458N1	N1	5.79	0.2280	28.0	66.0	36.0	6.00
R4585.8	–	5.80	0.2283	28.0	66.0	36.0	6.00
R4585.9	–	5.90	0.2323	28.0	66.0	36.0	6.00
R45815/64	15/64	5.95	0.2344	28.0	66.0	36.0	6.00
R4586.0	–	6.00	0.2362	28.0	66.0	36.0	6.00
R458B	B	6.05	0.2380	34.0	79.0	36.0	8.00
R4586.1	–	6.10	0.2402	34.0	79.0	36.0	8.00
R458C	C	6.15	0.2421	34.0	79.0	36.0	8.00
R4586.2	–	6.20	0.2441	34.0	79.0	36.0	8.00
R458D	D	6.25	0.2461	34.0	79.0	36.0	8.00
R4586.3	–	6.30	0.2480	34.0	79.0	36.0	8.00
R4581/4	1/4	6.35	0.2500	34.0	79.0	36.0	8.00
R4586.4	–	6.40	0.2520	34.0	79.0	36.0	8.00
R4586.5	–	6.50	0.2559	34.0	79.0	36.0	8.00
R458F	F	6.53	0.2571	34.0	79.0	36.0	8.00
R4586.6	–	6.60	0.2598	34.0	79.0	36.0	8.00
R458G	G	6.63	0.2610	34.0	79.0	36.0	8.00
R4586.7	–	6.70	0.2638	34.0	79.0	36.0	8.00
R45817/64	17/64	6.75	0.2656	34.0	79.0	36.0	8.00
R458H	H	6.76	0.2661	34.0	79.0	36.0	8.00
R4586.8	–	6.80	0.2677	34.0	79.0	36.0	8.00
R4586.9	–	6.90	0.2717	34.0	79.0	36.0	8.00

Product	DC	DC	DC	LCF	OAL	LS	DCON MS
	(inch)	(mm)	(inch)	(mm)	(mm)	(mm)	(mm)
R458I	I	6.91	0.2720	34.0	79.0	36.0	8.00
R4587.0	–	7.00	0.2756	34.0	79.0	36.0	8.00
R458J	J	7.04	0.2772	34.0	79.0	36.0	8.00
R4587.1	–	7.10	0.2795	41.0	79.0	36.0	8.00
R4589/32	9/32	7.14	0.2813	41.0	79.0	36.0	8.00
R4587.2	–	7.20	0.2835	41.0	79.0	36.0	8.00
R4587.3	–	7.30	0.2874	41.0	79.0	36.0	8.00
R458L	L	7.37	0.2902	41.0	79.0	36.0	8.00
R4587.4	–	7.40	0.2913	41.0	79.0	36.0	8.00
R4587.5	–	7.50	0.2953	41.0	79.0	36.0	8.00
R45819/64	19/64	7.54	0.2969	41.0	79.0	36.0	8.00
R4587.6	–	7.60	0.2992	41.0	79.0	36.0	8.00
R458N	N	7.67	0.3020	41.0	79.0	36.0	8.00
R4587.7	–	7.70	0.3031	41.0	79.0	36.0	8.00
R4587.8	–	7.80	0.3071	41.0	79.0	36.0	8.00
R4587.9	–	7.90	0.3110	41.0	79.0	36.0	8.00
R4585/16	5/16	7.94	0.3125	41.0	79.0	36.0	8.00
R4588.0	–	8.00	0.3150	41.0	79.0	36.0	8.00
R4580	O	8.03	0.3161	47.0	89.0	40.0	10.00
R4588.1	–	8.10	0.3189	47.0	89.0	40.0	10.00
R4588.2	–	8.20	0.3228	47.0	89.0	40.0	10.00
R4588.3	–	8.30	0.3268	47.0	89.0	40.0	10.00
R45821/64	21/64	8.33	0.3281	47.0	89.0	40.0	10.00
R4588.4	–	8.40	0.3307	47.0	89.0	40.0	10.00
R458Q	Q	8.43	0.3319	47.0	89.0	40.0	10.00
R4588.5	–	8.50	0.3346	47.0	89.0	40.0	10.00
R4588.6	–	8.60	0.3386	47.0	89.0	40.0	10.00
R458R	R	8.61	0.3390	47.0	89.0	40.0	10.00
R4588.7	–	8.70	0.3425	47.0	89.0	40.0	10.00
R45811/32	11/32	8.73	0.3438	47.0	89.0	40.0	10.00
R4588.8	–	8.80	0.3465	47.0	89.0	40.0	10.00
R458S	S	8.84	0.3480	47.0	89.0	40.0	10.00
R4588.9	–	8.90	0.3504	47.0	89.0	40.0	10.00
R4589.0	–	9.00	0.3543	47.0	89.0	40.0	10.00
R458T	T	9.09	0.3579	47.0	89.0	40.0	10.00
R4589.1	–	9.10	0.3583	47.0	89.0	40.0	10.00
R45823/64	23/64	9.13	0.3594	47.0	89.0	40.0	10.00
R4589.2	–	9.20	0.3622	47.0	89.0	40.0	10.00
R4589.3	–	9.30	0.3661	47.0	89.0	40.0	10.00
R458U	U	9.35	0.3681	47.0	89.0	40.0	10.00
R4589.4	–	9.40	0.3701	47.0	89.0	40.0	10.00
R4589.5	–	9.50	0.3740	47.0	89.0	40.0	10.00
R4583/8	3/8	9.53	0.3750	47.0	89.0	40.0	10.00
R458V	V	9.58	0.3772	47.0	89.0	40.0	10.00
R4589.6	–	9.60	0.3780	47.0	89.0	40.0	10.00
R4589.7	–	9.70	0.3819	47.0	89.0	40.0	10.00
R4589.8	–	9.80	0.3858	47.0	89.0	40.0	10.00
R4589.9	–	9.90	0.3898	47.0	89.0	40.0	10.00
R45825/64	25/64	9.92	0.3906	47.0	89.0	40.0	10.00
R45810.0	–	10.00	0.3937	47.0	89.0	40.0	10.00
R458X	X	10.08	0.3969	55.0	102.0	45.0	12.00
R45810.1	–	10.10	0.3976	55.0	102.0	45.0	12.00
R45810.2	–	10.20	0.4016	55.0	102.0	45.0	12.00
R458Y	Y	10.26	0.4039	55.0	102.0	45.0	12.00
R45810.3	–	10.30	0.4055	55.0	102.0	45.0	12.00
R45813/32	13/32	10.32	0.4063	55.0	102.0	45.0	12.00
R45810.4	–	10.40	0.4094	55.0	102.0	45.0	12.00
R45810.5	–	10.50	0.4134	55.0	102.0	45.0	12.00
R45810.6	–	10.60	0.4173	55.0	102.0	45.0	12.00
R45810.7	–	10.70	0.4213	55.0	102.0	45.0	12.00
R45827/64	27/64	10.72	0.4219	55.0	102.0	45.0	12.00
R45810.8	–	10.80	0.4252	55.0	102.0	45.0	12.00

Product	DC	DC	DC	LCF	OAL	LS	DCON MS
	(inch)	(mm)	(inch)	(mm)	(mm)	(mm)	(mm)
R45810.9	–	10.90	0.4291	55.0	102.0	45.0	12.00
R45811.0	–	11.00	0.4331	55.0	102.0	45.0	12.00
R45811.1	–	11.10	0.4370	55.0	102.0	45.0	12.00
R4587/16	7/16	11.11	0.4375	55.0	102.0	45.0	12.00
R45811.2	–	11.20	0.4409	55.0	102.0	45.0	12.00
R45811.3	–	11.30	0.4449	55.0	102.0	45.0	12.00
R45811.4	–	11.40	0.4488	55.0	102.0	45.0	12.00
R45811.5	–	11.50	0.4528	55.0	102.0	45.0	12.00
R45829/64	29/64	11.51	0.4531	55.0	102.0	45.0	12.00
R45811.6	–	11.60	0.4567	55.0	102.0	45.0	12.00
R45811.7	–	11.70	0.4606	55.0	102.0	45.0	12.00
R45811.8	–	11.80	0.4646	55.0	102.0	45.0	12.00
R45811.9	–	11.90	0.4685	55.0	102.0	45.0	12.00
R45815/32	15/32	11.91	0.4688	55.0	102.0	45.0	12.00
R45812.0	–	12.00	0.4724	55.0	102.0	45.0	12.00
R45812.1	–	12.10	0.4764	60.0	107.0	45.0	14.00
R45812.2	–	12.20	0.4803	60.0	107.0	45.0	14.00
R45831/64	31/64	12.30	0.4844	60.0	107.0	45.0	14.00
R45812.5	–	12.50	0.4921	60.0	107.0	45.0	14.00
R45812.7	–	12.70	0.5000	60.0	107.0	45.0	14.00
R4581/2	1/2	12.70	0.5000	60.0	107.0	45.0	14.00
R45812.8	–	12.80	0.5039	60.0	107.0	45.0	14.00
R45813.0	–	13.00	0.5118	60.0	107.0	45.0	14.00
R45833/64	33/64	13.10	0.5156	60.0	107.0	45.0	14.00
R45813.3	–	13.30	0.5236	60.0	107.0	45.0	14.00
R45817/32	17/32	13.49	0.5313	60.0	107.0	45.0	14.00
R45813.5	–	13.50	0.5315	60.0	107.0	45.0	14.00
R45813.8	–	13.80	0.5433	60.0	107.0	45.0	14.00
R45835/64	35/64	13.89	0.5469	60.0	107.0	45.0	14.00
R45814.0	–	14.00	0.5512	60.0	107.0	45.0	14.00
R45814.25	–	14.25	0.5610	65.0	115.0	48.0	16.00
R4589/16	9/16	14.29	0.5625	65.0	115.0	48.0	16.00
R45814.5	–	14.50	0.5709	65.0	115.0	48.0	16.00
R45837/64	37/64	14.68	0.5781	65.0	115.0	48.0	16.00
R45814.8	–	14.80	0.5827	65.0	115.0	48.0	16.00
R45815.0	–	15.00	0.5906	65.0	115.0	48.0	16.00
R45819/32	19/32	15.08	0.5938	65.0	115.0	48.0	16.00
R45815.1	–	15.10	0.5945	65.0	115.0	48.0	16.00
R45815.3	–	15.30	0.6024	65.0	115.0	48.0	16.00
R45839/64	39/64	15.48	0.6094	65.0	115.0	48.0	16.00
R45815.5	–	15.50	0.6102	65.0	115.0	48.0	16.00
R45815.8	–	15.80	0.6220	65.0	115.0	48.0	16.00
R4585/8	5/8	15.88	0.6250	65.0	115.0	48.0	16.00
R45816.0	–	16.00	0.6299	65.0	115.0	48.0	16.00
R45841/64	41/64	16.27	0.6406	73.0	123.0	48.0	18.00
R45816.5	–	16.50	0.6496	73.0	123.0	48.0	18.00
R45821/32	21/32	16.67	0.6563	73.0	123.0	48.0	18.00
R45817.0	–	17.00	0.6693	73.0	123.0	48.0	18.00
R45843/64	43/64	17.07	0.6720	73.0	123.0	48.0	18.00
R45811/16	11/16	17.46	0.6874	73.0	123.0	48.0	18.00
R45817.5	–	17.50	0.6890	73.0	123.0	48.0	18.00
R45817.8	–	17.80	0.7008	73.0	123.0	48.0	18.00
R45845/64	45/64	17.86	0.7031	73.0	123.0	48.0	18.00
R45818.0	–	18.00	0.7087	73.0	123.0	48.0	18.00
R45823/32	23/32	18.26	0.7189	79.0	131.0	50.0	20.00
R45818.5	–	18.50	0.7283	79.0	131.0	50.0	20.00
R45847/64	47/64	18.65	0.7343	79.0	131.0	50.0	20.00
R45819.0	–	19.00	0.7480	79.0	131.0	50.0	20.00
R4583/4	–	19.05	0.7500	79.0	131.0	50.0	20.00
R45819.5	–	19.50	0.7677	79.0	131.0	50.0	20.00
R45819.8	–	19.80	0.7795	79.0	131.0	50.0	20.00
R45820.0	–	20.00	0.7874	79.0	131.0	50.0	20.00

R457



Foret carbure monobloc FORCE X longueur 3xD avec arrosage centralisé, revêtement TiAlN

Foret haute performance multi-applications capable de produire des trous précis de haute qualité à des vitesses et des avances élevées (tolérance de trou H9). Pointe auto-centrante à 140° avec 4 facettes et une conception de goujure CTW pour un débit copeaux optimum. L'arrosage centralisé améliore l'évacuation des copeaux. Le revêtement TiAlN augmente la dureté en surface et améliore la durée de vie de l'outil.

FORCE X

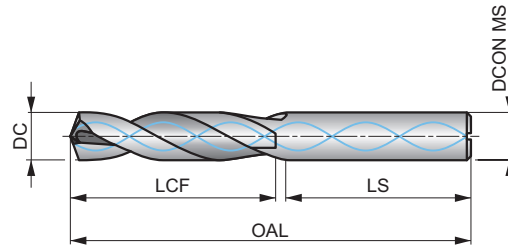

HM	DIN 6537K	3xD
140°	TiAlN	DIN 6535HA
CTW	R	
DC m7		

Adéquation du groupe de matériaux de la pièce, valeurs de départ pour la vitesse de coupe (m/min) et code Alpha d'avance. Les tableaux d'avances par tour se trouvent à partir de la page 274.

P1.1 ■ 179 W	P1.2 ■ 200 W	P1.3 ■ 207 W	P2.1 ■ 153 W	P2.2 ■ 135 W	P2.3 ■ 119 V	P3.1 ■ 133 V	P3.2 ■ 107 V	P3.3 ■ 90 V	P4.1 ■ 79 V	P4.2 ■ 67 V	P4.3 ■ 55 U	M1.1 ▣ 75 V	M1.2 ▣ 64 V
M2.1 ▣ 67 V	M2.2 ▣ 55 V	M2.3 ▣ 46 U	M3.1 ▣ 41 V	M3.2 ▣ 35 V	M3.3 ▣ 32 V	M4.1 ▣ 30 U	M4.2 ▣ 26 U	K1.1 ■ 110 W	K1.2 ■ 81 W	K1.3 ■ 61 W	K2.1 ■ 98 W	K2.2 ■ 80 V	K2.3 ■ 64 V
K3.1 ■ 87 V	K3.2 ■ 67 V	K3.3 ■ 54 V	K4.1 ■ 81 V	K4.2 ■ 61 V	K4.3 ■ 45 V	K4.4 ■ 38 V	K4.5 ■ 32 V	K5.1 ■ 91 V	K5.2 ■ 69 V	K5.3 ■ 53 V	N1.1 ■ 250 W	N1.2 ■ 188 W	N1.3 ■ 125 W
N2.1 ■ 308 V	N2.2 ■ 277 V	N2.3 ■ 200 V	N3.1 ■ 373 W	N3.2 ■ 220 W	N3.3 ■ 110 W	S1.1 ■ 55 V	S1.2 ■ 45 V	S1.3 ■ 40 U	H1.1 ■ 56 U	H2.1 ▣ 33 U	H2.2 ▣ 30 U	H3.1 ▣ 37 U	H3.2 ▣ 30 U

DCON MS tolérance h6.

Product	DC (inch)	DC (mm)	DC (inch)	LCF (mm)	OAL (mm)	LS (mm)	DCON MS (mm)
R4573.0	–	3.00	0.1181	20.0	62.0	36.0	6.00
R4573.1	–	3.10	0.1220	20.0	62.0	36.0	6.00
R4571/8	1/8	3.18	0.1250	20.0	62.0	36.0	6.00
R4573.2	–	3.20	0.1260	20.0	62.0	36.0	6.00
R457N30	N30	3.26	0.1283	20.0	62.0	36.0	6.00
R4573.3	–	3.30	0.1299	20.0	62.0	36.0	6.00
R4573.4	–	3.40	0.1339	20.0	62.0	36.0	6.00
R457N29	N29	3.45	0.1360	20.0	62.0	36.0	6.00
R4573.5	–	3.50	0.1378	20.0	62.0	36.0	6.00
R457N28	N28	3.57	0.1406	20.0	62.0	36.0	6.00
R4579/64	9/64	3.57	0.1406	20.0	62.0	36.0	6.00
R4573.6	–	3.60	0.1417	20.0	62.0	36.0	6.00
R457N27	N27	3.66	0.1441	20.0	62.0	36.0	6.00
R4573.7	–	3.70	0.1457	20.0	62.0	36.0	6.00
R457N26	N26	3.73	0.1469	24.0	66.0	36.0	6.00
R457N25	N25	3.80	0.1496	24.0	66.0	36.0	6.00
R4573.8	–	3.80	0.1496	24.0	66.0	36.0	6.00
R457N24	N24	3.86	0.1520	24.0	66.0	36.0	6.00
R4573.9	–	3.90	0.1535	24.0	66.0	36.0	6.00
R457N23	N23	3.91	0.1539	24.0	66.0	36.0	6.00
R4575/32	5/32	3.97	0.1563	24.0	66.0	36.0	6.00
R457N22	N22	3.99	0.1571	24.0	66.0	36.0	6.00
R4574.0	–	4.00	0.1575	24.0	66.0	36.0	6.00
R457N21	N21	4.04	0.1591	24.0	66.0	36.0	6.00
R4574.05	–	4.05	0.1594	24.0	66.0	36.0	6.00

Product	DC	DC	DC	LCF	OAL	LS	DCON MS
	(inch)	(mm)	(inch)	(mm)	(mm)	(mm)	(mm)
R457N20	N20	4.09	0.1610	24.0	66.0	36.0	6.00
R4574.1	–	4.10	0.1614	24.0	66.0	36.0	6.00
R4574.2	–	4.20	0.1654	24.0	66.0	36.0	6.00
R4574.3	–	4.30	0.1693	24.0	66.0	36.0	6.00
R457N18	N18	4.31	0.1697	24.0	66.0	36.0	6.00
R45711/64	11/64	4.37	0.1719	24.0	66.0	36.0	6.00
R457N17	N17	4.39	0.1728	24.0	66.0	36.0	6.00
R4574.4	–	4.40	0.1732	24.0	66.0	36.0	6.00
R4574.5	–	4.50	0.1772	24.0	66.0	36.0	6.00
R457N16	N16	4.50	0.1772	24.0	66.0	36.0	6.00
R457N15	N15	4.57	0.1799	24.0	66.0	36.0	6.00
R4574.6	–	4.60	0.1811	24.0	66.0	36.0	6.00
R457N14	N14	4.62	0.1819	24.0	66.0	36.0	6.00
R4574.7	–	4.70	0.1850	24.0	66.0	36.0	6.00
R4573/16	3/16	4.76	0.1875	28.0	66.0	36.0	6.00
R4574.8	–	4.80	0.1890	28.0	66.0	36.0	6.00
R457N11	N11	4.85	0.1909	28.0	66.0	36.0	6.00
R4574.9	–	4.90	0.1929	28.0	66.0	36.0	6.00
R457N9	N9	4.98	0.1961	28.0	66.0	36.0	6.00
R4575.0	–	5.00	0.1969	28.0	66.0	36.0	6.00
R4575.05	–	5.05	0.1988	28.0	66.0	36.0	6.00
R457N8	N8	5.06	0.1992	28.0	66.0	36.0	6.00
R4575.1	–	5.10	0.2008	28.0	66.0	36.0	6.00
R457N7	N7	5.11	0.2010	28.0	66.0	36.0	6.00
R45713/64	13/64	5.16	0.2031	28.0	66.0	36.0	6.00
R457N6	N6	5.18	0.2039	28.0	66.0	36.0	6.00
R4575.2	–	5.20	0.2047	28.0	66.0	36.0	6.00
R457N5	N5	5.22	0.2055	28.0	66.0	36.0	6.00
R4575.3	–	5.30	0.2087	28.0	66.0	36.0	6.00
R457N4	N4	5.31	0.2091	28.0	66.0	36.0	6.00
R4575.4	–	5.40	0.2126	28.0	66.0	36.0	6.00
R457N3	N3	5.41	0.2130	28.0	66.0	36.0	6.00
R4575.5	–	5.50	0.2165	28.0	66.0	36.0	6.00
R4577/32	7/32	5.56	0.2188	28.0	66.0	36.0	6.00
R4575.6	–	5.60	0.2205	28.0	66.0	36.0	6.00
R457N2	N2	5.61	0.2209	28.0	66.0	36.0	6.00
R4575.7	–	5.70	0.2244	28.0	66.0	36.0	6.00
R457N1	N1	5.79	0.2280	28.0	66.0	36.0	6.00
R4575.8	–	5.80	0.2283	28.0	66.0	36.0	6.00
R4575.9	–	5.90	0.2323	28.0	66.0	36.0	6.00
R457A	A	5.94	0.2339	28.0	66.0	36.0	6.00
R45715/64	15/64	5.95	0.2344	28.0	66.0	36.0	6.00
R4576.0	–	6.00	0.2362	28.0	66.0	36.0	6.00
R457B	B	6.05	0.2380	34.0	79.0	36.0	8.00
R4576.05	–	6.05	0.2382	34.0	79.0	36.0	8.00
R4576.1	–	6.10	0.2402	34.0	79.0	36.0	8.00
R457C	C	6.15	0.2421	34.0	79.0	36.0	8.00
R4576.2	–	6.20	0.2441	34.0	79.0	36.0	8.00
R457D	D	6.25	0.2461	34.0	79.0	36.0	8.00
R4576.3	–	6.30	0.2480	34.0	79.0	36.0	8.00
R4571/4	1/4	6.35	0.2500	34.0	79.0	36.0	8.00
R4576.4	–	6.40	0.2520	34.0	79.0	36.0	8.00
R4576.5	–	6.50	0.2559	34.0	79.0	36.0	8.00
R457F	F	6.53	0.2571	34.0	79.0	36.0	8.00
R4576.6	–	6.60	0.2598	34.0	79.0	36.0	8.00
R457G	G	6.63	0.2610	34.0	79.0	36.0	8.00
R4576.7	–	6.70	0.2638	34.0	79.0	36.0	8.00
R45717/64	17/64	6.75	0.2656	34.0	79.0	36.0	8.00
R4576.8	–	6.80	0.2677	34.0	79.0	36.0	8.00
R4576.9	–	6.90	0.2717	34.0	79.0	36.0	8.00
R457I	I	6.91	0.2720	34.0	79.0	36.0	8.00
R4577.0	–	7.00	0.2756	34.0	79.0	36.0	8.00



Product	DC	DC	DC	LCF	OAL	LS	DCON MS
	(inch)	(mm)	(inch)	(mm)	(mm)	(mm)	(mm)
R457J	J	7.04	0.2772	41.0	79.0	36.0	8.00
R4577.1	–	7.10	0.2795	41.0	79.0	36.0	8.00
R4579/32	9/32	7.14	0.2813	41.0	79.0	36.0	8.00
R4577.2	–	7.20	0.2835	41.0	79.0	36.0	8.00
R4577.3	–	7.30	0.2874	41.0	79.0	36.0	8.00
R4577.4	–	7.40	0.2913	41.0	79.0	36.0	8.00
R4577.5	–	7.50	0.2953	41.0	79.0	36.0	8.00
R45719/64	19/64	7.54	0.2969	41.0	79.0	36.0	8.00
R4577.6	–	7.60	0.2992	41.0	79.0	36.0	8.00
R457N	N	7.67	0.3020	41.0	79.0	36.0	8.00
R4577.7	–	7.70	0.3031	41.0	79.0	36.0	8.00
R4577.8	–	7.80	0.3071	41.0	79.0	36.0	8.00
R4577.9	–	7.90	0.3110	41.0	79.0	36.0	8.00
R4575/16	5/16	7.94	0.3125	41.0	79.0	36.0	8.00
R4578.0	–	8.00	0.3150	41.0	79.0	36.0	8.00
R4570	O	8.03	0.3161	47.0	89.0	40.0	10.00
R4578.05	–	8.05	0.3169	47.0	89.0	40.0	10.00
R4578.1	–	8.10	0.3189	47.0	89.0	40.0	10.00
R4578.2	–	8.20	0.3228	47.0	89.0	40.0	10.00
R457P	P	8.20	0.3228	47.0	89.0	40.0	10.00
R4578.3	–	8.30	0.3268	47.0	89.0	40.0	10.00
R45721/64	21/64	8.33	0.3281	47.0	89.0	40.0	10.00
R4578.4	–	8.40	0.3307	47.0	89.0	40.0	10.00
R457Q	Q	8.43	0.3319	47.0	89.0	40.0	10.00
R4578.5	–	8.50	0.3346	47.0	89.0	40.0	10.00
R4578.6	–	8.60	0.3386	47.0	89.0	40.0	10.00
R457R	R	8.61	0.3390	47.0	89.0	40.0	10.00
R4578.7	–	8.70	0.3425	47.0	89.0	40.0	10.00
R45711/32	11/32	8.73	0.3438	47.0	89.0	40.0	10.00
R4578.8	–	8.80	0.3465	47.0	89.0	40.0	10.00
R457S	S	8.84	0.3480	47.0	89.0	40.0	10.00
R4578.9	–	8.90	0.3504	47.0	89.0	40.0	10.00
R4579.0	–	9.00	0.3543	47.0	89.0	40.0	10.00
R4579.1	–	9.10	0.3583	47.0	89.0	40.0	10.00
R45723/64	23/64	9.13	0.3594	47.0	89.0	40.0	10.00
R4579.2	–	9.20	0.3622	47.0	89.0	40.0	10.00
R4579.3	–	9.30	0.3661	47.0	89.0	40.0	10.00
R457U	U	9.35	0.3681	47.0	89.0	40.0	10.00
R4579.4	–	9.40	0.3701	47.0	89.0	40.0	10.00
R4579.5	–	9.50	0.3740	47.0	89.0	40.0	10.00
R4573/8	3/8	9.53	0.3750	47.0	89.0	40.0	10.00
R457V	V	9.58	0.3772	47.0	89.0	40.0	10.00
R4579.6	–	9.60	0.3780	47.0	89.0	40.0	10.00
R4579.7	–	9.70	0.3819	47.0	89.0	40.0	10.00
R4579.8	–	9.80	0.3858	47.0	89.0	40.0	10.00
R457W	W	9.80	0.3858	47.0	89.0	40.0	10.00
R4579.9	–	9.90	0.3898	47.0	89.0	40.0	10.00
R45725/64	25/64	9.92	0.3906	47.0	89.0	40.0	10.00
R45710.0	–	10.00	0.3937	47.0	89.0	40.0	10.00
R45710.05	–	10.05	0.3957	55.0	102.0	45.0	12.00
R457X	X	10.08	0.3969	55.0	102.0	45.0	12.00
R45710.1	–	10.10	0.3976	55.0	102.0	45.0	12.00
R45710.2	–	10.20	0.4016	55.0	102.0	45.0	12.00
R457Y	Y	10.26	0.4039	55.0	102.0	45.0	12.00
R45710.3	–	10.30	0.4055	55.0	102.0	45.0	12.00
R45713/32	13/32	10.32	0.4063	55.0	102.0	45.0	12.00
R45710.4	–	10.40	0.4094	55.0	102.0	45.0	12.00
R457Z	Z	10.49	0.4130	55.0	102.0	45.0	12.00
R45710.5	–	10.50	0.4134	55.0	102.0	45.0	12.00
R45710.6	–	10.60	0.4173	55.0	102.0	45.0	12.00
R45727/64	27/64	10.72	0.4219	55.0	102.0	45.0	12.00
R45710.8	–	10.80	0.4252	55.0	102.0	45.0	12.00

Product	DC	DC	DC	LCF	OAL	LS	DCON MS
	(inch)	(mm)	(inch)	(mm)	(mm)	(mm)	(mm)
R45711.0	–	11.00	0.4331	55.0	102.0	45.0	12.00
R4577/16	7/16	11.11	0.4375	55.0	102.0	45.0	12.00
R45711.2	–	11.20	0.4409	55.0	102.0	45.0	12.00
R45711.3	–	11.30	0.4449	55.0	102.0	45.0	12.00
R45711.4	–	11.40	0.4488	55.0	102.0	45.0	12.00
R45711.5	–	11.50	0.4528	55.0	102.0	45.0	12.00
R45729/64	29/64	11.51	0.4531	55.0	102.0	45.0	12.00
R45711.6	–	11.60	0.4567	55.0	102.0	45.0	12.00
R45711.8	–	11.80	0.4646	55.0	102.0	45.0	12.00
R45715/32	15/32	11.91	0.4688	55.0	102.0	45.0	12.00
R45712.0	–	12.00	0.4724	55.0	102.0	45.0	12.00
R45712.05	–	12.05	0.4744	60.0	107.0	45.0	14.00
R45712.1	–	12.10	0.4764	60.0	107.0	45.0	14.00
R45712.2	–	12.20	0.4803	60.0	107.0	45.0	14.00
R45731/64	31/64	12.30	0.4844	60.0	107.0	45.0	14.00
R45712.5	–	12.50	0.4921	60.0	107.0	45.0	14.00
R45712.7	–	12.70	0.5000	60.0	107.0	45.0	14.00
R4571/2	1/2	12.70	0.5000	60.0	107.0	45.0	14.00
R45712.8	–	12.80	0.5039	60.0	107.0	45.0	14.00
R45713.0	–	13.00	0.5118	60.0	107.0	45.0	14.00
R45733/64	33/64	13.10	0.5156	60.0	107.0	45.0	14.00
R45713.3	–	13.30	0.5236	60.0	107.0	45.0	14.00
R45717/32	17/32	13.49	0.5313	60.0	107.0	45.0	14.00
R45713.5	–	13.50	0.5315	60.0	107.0	45.0	14.00
R45713.8	–	13.80	0.5433	60.0	107.0	45.0	14.00
R45735/64	35/64	13.89	0.5469	60.0	107.0	45.0	14.00
R45714.0	–	14.00	0.5512	60.0	107.0	45.0	14.00
R45714.25	–	14.25	0.5610	65.0	115.0	48.0	16.00
R4579/16	9/16	14.29	0.5625	65.0	115.0	48.0	16.00
R45714.5	–	14.50	0.5709	65.0	115.0	48.0	16.00
R45737/64	37/64	14.68	0.5781	65.0	115.0	48.0	16.00
R45714.8	–	14.80	0.5827	65.0	115.0	48.0	16.00
R45715.0	–	15.00	0.5906	65.0	115.0	48.0	16.00
R45719/32	19/32	15.08	0.5938	65.0	115.0	48.0	16.00
R45715.1	–	15.10	0.5945	65.0	115.0	48.0	16.00
R45715.3	–	15.30	0.6024	65.0	115.0	48.0	16.00
R45739/64	39/64	15.48	0.6094	65.0	115.0	48.0	16.00
R45715.5	–	15.50	0.6102	65.0	115.0	48.0	16.00
R45715.8	–	15.80	0.6220	65.0	115.0	48.0	16.00
R4575/8	5/8	15.88	0.6250	65.0	115.0	48.0	16.00
R45716.0	–	16.00	0.6299	65.0	115.0	48.0	16.00
R45741/64	41/64	16.27	0.6406	73.0	123.0	48.0	18.00
R45716.5	–	16.50	0.6496	73.0	123.0	48.0	18.00
R45721/32	21/32	16.67	0.6563	73.0	123.0	48.0	18.00
R45717.0	–	17.00	0.6693	73.0	123.0	48.0	18.00
R45743/64	43/64	17.07	0.6720	73.0	123.0	48.0	18.00
R45711/16	11/16	17.46	0.6874	73.0	123.0	48.0	18.00
R45717.5	–	17.50	0.6890	73.0	123.0	48.0	18.00
R45745/64	45/64	17.86	0.7031	73.0	123.0	48.0	18.00
R45718.0	–	18.00	0.7087	73.0	123.0	48.0	18.00
R45723/32	23/32	18.26	0.7189	79.0	131.0	50.0	20.00
R45718.5	–	18.50	0.7283	79.0	131.0	50.0	20.00
R45747/64	47/64	18.65	0.7343	79.0	131.0	50.0	20.00
R45718.8	–	18.80	0.7402	79.0	131.0	50.0	20.00
R45719.0	–	19.00	0.7480	79.0	131.0	50.0	20.00
R4573/4	3/4	19.05	0.7500	79.0	131.0	50.0	20.00
R45719.5	–	19.50	0.7677	79.0	131.0	50.0	20.00
R45719.8	–	19.80	0.7795	79.0	131.0	50.0	20.00
R45720.0	–	20.00	0.7874	79.0	131.0	50.0	20.00

R454



Foret carbure monobloc FORCE X longueur 5xD, revêtement TiAlN

Foret haute performance multi-applications capable de produire des trous précis de haute qualité à des vitesses et des avances élevées (tolérance de trou H9). Pointe auto-centrante à 140° avec 4 facettes et une conception de goujure CTW pour un débit copeaux optimum. Le revêtement TiAlN augmente la dureté en surface et améliore la durée de vie de l'outil.

FORCE X

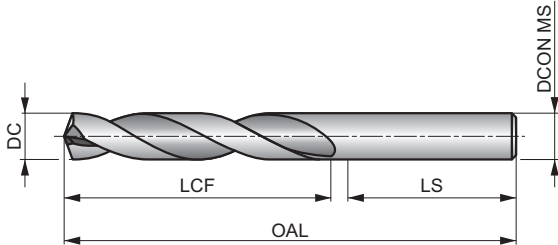

HM	DIN 6537L	5xD
140°	TiAlN	DIN 6535HA
CTW	R	DC m7

Adéquation du groupe de matériaux de la pièce, valeurs de départ pour la vitesse de coupe (m/min) et code Alpha d'avance. Les tableaux d'avances par tour se trouvent à partir de la page 274.

P1.1 ■ 134V	P1.2 ■ 150V	P1.3 ■ 155V	P2.1 ■ 115V	P2.2 ■ 101V	P2.3 ■ 89V	P3.1 ■ 100V	P3.2 ■ 80V	P3.3 ■ 68V	P4.1 ■ 59V	P4.2 ■ 50V	P4.3 ■ 41U	M1.1 ▣ 56U	M1.2 ▣ 48U
M2.1 ▣ 50U	M2.2 ▣ 41U	M2.3 ▣ 35T	M3.1 ▣ 31T	M3.2 ▣ 26T	M3.3 ▣ 24T	M4.1 ▣ 23T	M4.2 ▣ 20T	K1.1 ■ 83W	K1.2 ■ 61W	K1.3 ■ 46W	K2.1 ■ 74V	K2.2 ■ 60V	K2.3 ■ 48V
K3.1 ■ 65V	K3.2 ■ 50V	K3.3 ■ 41V	K4.1 ■ 61V	K4.2 ■ 46V	K4.3 ■ 34V	K4.4 ■ 29V	K4.5 ■ 24V	K5.1 ■ 68V	K5.2 ■ 52V	K5.3 ■ 40V	N1.1 ■ 188W	N1.2 ■ 141W	N1.3 ■ 94W
N2.1 ■ 231V	N2.2 ■ 208V	N2.3 ■ 150V	N3.1 ■ 280V	N3.2 ■ 165V	N3.3 ■ 83V	S1.1 ▣ 41U	S1.2 ▣ 34U	S1.3 ▣ 30T	H1.1 ■ 42U	H2.1 ▣ 25U	H2.2 ▣ 23U	H3.1 ▣ 28U	H3.2 ▣ 23U

DCON MS tolérance h6.

Product	DC (inch)	DC (mm)	DC (inch)	LCF (mm)	OAL (mm)	LS (mm)	DCON MS (mm)
R4543.0	–	3.00	0.1181	28.0	66.0	36.0	6.00
R4543.1	–	3.10	0.1220	28.0	66.0	36.0	6.00
R4541/8	1/8	3.18	0.1250	28.0	66.0	36.0	6.00
R4543.2	–	3.20	0.1260	28.0	66.0	36.0	6.00
R454N30	N30	3.26	0.1283	28.0	66.0	36.0	6.00
R4543.3	–	3.30	0.1299	28.0	66.0	36.0	6.00
R4543.4	–	3.40	0.1339	28.0	66.0	36.0	6.00
R454N29	N29	3.45	0.1360	28.0	66.0	36.0	6.00
R4543.5	–	3.50	0.1378	28.0	66.0	36.0	6.00
R454N28	N28	3.57	0.1406	28.0	66.0	36.0	6.00
R4549/64	9/64	3.57	0.1406	28.0	66.0	36.0	6.00
R4543.6	–	3.60	0.1417	28.0	66.0	36.0	6.00
R454N27	N27	3.66	0.1441	28.0	66.0	36.0	6.00
R4543.7	–	3.70	0.1457	28.0	66.0	36.0	6.00
R454N26	N26	3.73	0.1469	36.0	74.0	36.0	6.00
R4543.8	–	3.80	0.1496	36.0	74.0	36.0	6.00
R454N24	N24	3.86	0.1520	36.0	74.0	36.0	6.00
R4543.9	–	3.90	0.1535	36.0	74.0	36.0	6.00
R4545/32	5/32	3.97	0.1563	36.0	74.0	36.0	6.00
R4544.0	–	4.00	0.1575	36.0	74.0	36.0	6.00
R454N21	N21	4.04	0.1591	36.0	74.0	36.0	6.00
R454N20	N20	4.09	0.1610	36.0	74.0	36.0	6.00
R4544.1	–	4.10	0.1614	36.0	74.0	36.0	6.00
R4544.2	–	4.20	0.1654	36.0	74.0	36.0	6.00
R454N19	N19	4.22	0.1661	36.0	74.0	36.0	6.00

Product	DC	DC	DC	LCF	OAL	LS	DCON MS
	(inch)	(mm)	(inch)	(mm)	(mm)	(mm)	(mm)
R4544.3	–	4.30	0.1693	36.0	74.0	36.0	6.00
R45411/64	11/64	4.37	0.1719	36.0	74.0	36.0	6.00
R4544.4	–	4.40	0.1732	36.0	74.0	36.0	6.00
R4544.5	–	4.50	0.1772	36.0	74.0	36.0	6.00
R454N16	N16	4.50	0.1772	36.0	74.0	36.0	6.00
R454N15	N15	4.57	0.1799	36.0	74.0	36.0	6.00
R4544.6	–	4.60	0.1811	36.0	74.0	36.0	6.00
R454N14	N14	4.62	0.1819	36.0	74.0	36.0	6.00
R4544.7	–	4.70	0.1850	36.0	74.0	36.0	6.00
R4543/16	3/16	4.76	0.1875	44.0	82.0	36.0	6.00
R4544.8	–	4.80	0.1890	44.0	82.0	36.0	6.00
R454N11	N11	4.85	0.1909	44.0	82.0	36.0	6.00
R4544.9	–	4.90	0.1929	44.0	82.0	36.0	6.00
R454N10	N10	4.92	0.1937	44.0	82.0	36.0	6.00
R454N9	N9	4.98	0.1961	44.0	82.0	36.0	6.00
R4545.0	–	5.00	0.1969	44.0	82.0	36.0	6.00
R454N8	N8	5.06	0.1992	44.0	82.0	36.0	6.00
R4545.1	–	5.10	0.2008	44.0	82.0	36.0	6.00
R454N7	N7	5.11	0.2010	44.0	82.0	36.0	6.00
R45413/64	13/64	5.16	0.2031	44.0	82.0	36.0	6.00
R454N6	N6	5.18	0.2039	44.0	82.0	36.0	6.00
R4545.2	–	5.20	0.2047	44.0	82.0	36.0	6.00
R454N5	N5	5.22	0.2055	44.0	82.0	36.0	6.00
R454N4	N4	5.31	0.2091	44.0	82.0	36.0	6.00
R454N3	N3	5.41	0.2130	44.0	82.0	36.0	6.00
R4545.5	–	5.50	0.2165	44.0	82.0	36.0	6.00
R4547/32	7/32	5.56	0.2188	44.0	82.0	36.0	6.00
R4545.6	–	5.60	0.2205	44.0	82.0	36.0	6.00
R454N2	N2	5.61	0.2209	44.0	82.0	36.0	6.00
R4545.7	–	5.70	0.2244	44.0	82.0	36.0	6.00
R454N1	N1	5.79	0.2280	44.0	82.0	36.0	6.00
R4545.8	–	5.80	0.2283	44.0	82.0	36.0	6.00
R454A	A	5.94	0.2339	44.0	82.0	36.0	6.00
R45415/64	15/64	5.95	0.2344	44.0	82.0	36.0	6.00
R4546.0	–	6.00	0.2362	44.0	82.0	36.0	6.00
R454B	B	6.05	0.2380	53.0	91.0	36.0	8.00
R4546.1	–	6.10	0.2402	53.0	91.0	36.0	8.00
R454C	C	6.15	0.2421	53.0	91.0	36.0	8.00
R4546.2	–	6.20	0.2441	53.0	91.0	36.0	8.00
R454D	D	6.25	0.2461	53.0	91.0	36.0	8.00
R4546.3	–	6.30	0.2480	53.0	91.0	36.0	8.00
R4541/4	1/4	6.35	0.2500	53.0	91.0	36.0	8.00
R454E	E	6.35	0.2500	53.0	91.0	36.0	8.00
R4546.4	–	6.40	0.2520	53.0	91.0	36.0	8.00
R4546.5	–	6.50	0.2559	53.0	91.0	36.0	8.00
R454F	F	6.53	0.2571	53.0	91.0	36.0	8.00
R4546.6	–	6.60	0.2598	53.0	91.0	36.0	8.00
R454G	G	6.63	0.2610	53.0	91.0	36.0	8.00
R4546.7	–	6.70	0.2638	53.0	91.0	36.0	8.00
R45417/64	17/64	6.75	0.2656	53.0	91.0	36.0	8.00
R454H	H	6.76	0.2661	53.0	91.0	36.0	8.00
R4546.8	–	6.80	0.2677	53.0	91.0	36.0	8.00
R4546.9	–	6.90	0.2717	53.0	91.0	36.0	8.00
R454I	I	6.91	0.2720	53.0	91.0	36.0	8.00
R4547.0	–	7.00	0.2756	53.0	91.0	36.0	8.00
R454J	J	7.04	0.2772	53.0	91.0	36.0	8.00
R4547.1	–	7.10	0.2795	53.0	91.0	36.0	8.00
R4549/32	9/32	7.14	0.2813	53.0	91.0	36.0	8.00
R4547.3	–	7.30	0.2874	53.0	91.0	36.0	8.00
R454L	L	7.37	0.2902	53.0	91.0	36.0	8.00
R4547.4	–	7.40	0.2913	53.0	91.0	36.0	8.00
R4547.5	–	7.50	0.2953	53.0	91.0	36.0	8.00



Product	DC	DC	DC	LCF	OAL	LS	DCON MS
	(inch)	(mm)	(inch)	(mm)	(mm)	(mm)	(mm)
R45419/64	19/64	7.54	0.2969	53.0	91.0	36.0	8.00
R4547.6	–	7.60	0.2992	53.0	91.0	36.0	8.00
R454N	N	7.67	0.3020	53.0	91.0	36.0	8.00
R4547.7	–	7.70	0.3031	53.0	91.0	36.0	8.00
R4547.8	–	7.80	0.3071	53.0	91.0	36.0	8.00
R4547.9	–	7.90	0.3110	53.0	91.0	36.0	8.00
R4545/16	5/16	7.94	0.3125	53.0	91.0	36.0	8.00
R4548.0	–	8.00	0.3150	53.0	91.0	36.0	8.00
R4540	0	8.03	0.3161	61.0	103.0	40.0	10.00
R4548.1	–	8.10	0.3189	61.0	103.0	40.0	10.00
R4548.2	–	8.20	0.3228	61.0	103.0	40.0	10.00
R45421/64	21/64	8.33	0.3281	61.0	103.0	40.0	10.00
R4548.4	–	8.40	0.3307	61.0	103.0	40.0	10.00
R454Q	Q	8.43	0.3319	61.0	103.0	40.0	10.00
R4548.5	–	8.50	0.3346	61.0	103.0	40.0	10.00
R4548.6	–	8.60	0.3386	61.0	103.0	40.0	10.00
R454R	R	8.61	0.3390	61.0	103.0	40.0	10.00
R4548.7	–	8.70	0.3425	61.0	103.0	40.0	10.00
R45411/32	11/32	8.73	0.3438	61.0	103.0	40.0	10.00
R4548.8	–	8.80	0.3465	61.0	103.0	40.0	10.00
R454S	S	8.84	0.3480	61.0	103.0	40.0	10.00
R4548.9	–	8.90	0.3504	61.0	103.0	40.0	10.00
R4549.0	–	9.00	0.3543	61.0	103.0	40.0	10.00
R4549.1	–	9.10	0.3583	61.0	103.0	40.0	10.00
R45423/64	23/64	9.13	0.3594	61.0	103.0	40.0	10.00
R4549.3	–	9.30	0.3661	61.0	103.0	40.0	10.00
R454U	U	9.35	0.3681	61.0	103.0	40.0	10.00
R4549.4	–	9.40	0.3701	61.0	103.0	40.0	10.00
R4549.5	–	9.50	0.3740	61.0	103.0	40.0	10.00
R4543/8	3/8	9.53	0.3750	61.0	103.0	40.0	10.00
R4549.6	–	9.60	0.3780	61.0	103.0	40.0	10.00
R4549.7	–	9.70	0.3819	61.0	103.0	40.0	10.00
R4549.8	–	9.80	0.3858	61.0	103.0	40.0	10.00
R4549.9	–	9.90	0.3898	61.0	103.0	40.0	10.00
R454W	W	9.80	0.3858	61.0	103.0	40.0	10.00
R45425/64	25/64	9.92	0.3906	61.0	103.0	40.0	10.00
R45410.0	–	10.00	0.3937	61.0	103.0	40.0	10.00
R454X	X	10.08	0.3969	70.0	118.0	45.0	12.00
R45410.1	–	10.10	0.3976	70.0	118.0	45.0	12.00
R45410.2	–	10.20	0.4016	70.0	118.0	45.0	12.00
R454Y	Y	10.26	0.4039	70.0	118.0	45.0	12.00
R45410.3	–	10.30	0.4055	70.0	118.0	45.0	12.00
R45413/32	13/32	10.32	0.4063	70.0	118.0	45.0	12.00
R45410.4	–	10.40	0.4094	70.0	118.0	45.0	12.00
R454Z	Z	10.49	0.4130	70.0	118.0	45.0	12.00
R45410.5	–	10.50	0.4134	70.0	118.0	45.0	12.00
R45410.6	–	10.60	0.4173	70.0	118.0	45.0	12.00
R45427/64	27/64	10.72	0.4219	70.0	118.0	45.0	12.00
R45411.0	–	11.00	0.4331	70.0	118.0	45.0	12.00
R4547/16	7/16	11.11	0.4375	70.0	118.0	45.0	12.00
R45411.2	–	11.20	0.4409	70.0	118.0	45.0	12.00
R45411.4	–	11.40	0.4488	70.0	118.0	45.0	12.00
R45411.5	–	11.50	0.4528	70.0	118.0	45.0	12.00
R45429/64	29/64	11.51	0.4531	70.0	118.0	45.0	12.00
R45411.6	–	11.60	0.4567	70.0	118.0	45.0	12.00
R45411.8	–	11.80	0.4646	70.0	118.0	45.0	12.00
R45415/32	15/32	11.91	0.4688	70.0	118.0	45.0	12.00
R45412.0	–	12.00	0.4724	70.0	118.0	45.0	12.00
R45412.1	–	12.10	0.4764	76.0	124.0	45.0	14.00
R45412.2	–	12.20	0.4803	76.0	124.0	45.0	14.00
R45431/64	31/64	12.30	0.4844	76.0	124.0	45.0	14.00
R45412.5	–	12.50	0.4921	76.0	124.0	45.0	14.00

Product	DC	DC	DC	LCF	OAL	LS	DCON MS
	(inch)	(mm)	(inch)	(mm)	(mm)	(mm)	(mm)
R45412.7	–	12.70	0.5000	76.0	124.0	45.0	14.00
R4541/2	1/2	12.70	0.5000	76.0	124.0	45.0	14.00
R45412.8	–	12.80	0.5039	76.0	124.0	45.0	14.00
R45413.0	–	13.00	0.5118	76.0	124.0	45.0	14.00
R45433/64	33/64	13.10	0.5156	76.0	124.0	45.0	14.00
R45417/32	17/32	13.49	0.5313	76.0	124.0	45.0	14.00
R45413.5	–	13.50	0.5315	76.0	124.0	45.0	14.00
R45413.8	–	13.80	0.5433	76.0	124.0	45.0	14.00
R45435/64	35/64	13.89	0.5469	76.0	124.0	45.0	14.00
R45414.0	–	14.00	0.5512	76.0	124.0	45.0	14.00
R45414.25	–	14.25	0.5610	82.0	133.0	48.0	16.00
R4549/16	9/16	14.29	0.5625	82.0	133.0	48.0	16.00
R45414.5	–	14.50	0.5709	82.0	133.0	48.0	16.00
R45437/64	37/64	14.68	0.5781	82.0	133.0	48.0	16.00
R45414.8	–	14.80	0.5827	82.0	133.0	48.0	16.00
R45415.0	–	15.00	0.5906	82.0	133.0	48.0	16.00
R45419/32	19/32	15.08	0.5938	82.0	133.0	48.0	16.00
R45415.1	–	15.10	0.5945	82.0	133.0	48.0	16.00
R45439/64	39/64	15.48	0.6094	82.0	133.0	48.0	16.00
R45415.5	–	15.50	0.6102	82.0	133.0	48.0	16.00
R45415.8	–	15.80	0.6220	82.0	133.0	48.0	16.00
R4545/8	5/8	15.88	0.6250	82.0	133.0	48.0	16.00
R45416.0	–	16.00	0.6299	82.0	133.0	48.0	16.00
R45441/64	41/64	16.27	0.6406	91.0	143.0	48.0	18.00
R45416.5	–	16.50	0.6496	91.0	143.0	48.0	18.00
R45421/32	21/32	16.67	0.6563	91.0	143.0	48.0	18.00
R45417.0	–	17.00	0.6693	91.0	143.0	48.0	18.00
R45443/64	43/64	17.07	0.6720	91.0	143.0	48.0	18.00
R45411/16	11/16	17.46	0.6874	91.0	143.0	48.0	18.00
R45417.5	–	17.50	0.6890	91.0	143.0	48.0	18.00
R45417.8	–	17.80	0.7008	91.0	143.0	48.0	18.00
R45445/64	45/64	17.86	0.7031	91.0	143.0	48.0	18.00
R45418.0	–	18.00	0.7087	91.0	143.0	48.0	18.00
R45423/32	23/32	18.26	0.7189	99.0	153.0	50.0	20.00
R45418.5	–	18.50	0.7283	99.0	153.0	50.0	20.00
R45447/64	47/64	18.65	0.7343	99.0	153.0	50.0	20.00
R45419.0	–	19.00	0.7480	99.0	153.0	50.0	20.00
R4543/4	3/4	19.05	0.7500	99.0	153.0	50.0	20.00
R45419.5	–	19.50	0.7677	99.0	153.0	50.0	20.00
R45419.8	–	19.80	0.7795	99.0	153.0	50.0	20.00
R45420.0	–	20.00	0.7874	99.0	153.0	50.0	20.00

R453



Foret carbure monobloc FORCE X longueur 5xD avec arrosage centralisé, revêtement TiAlN

Foret haute performance multi-applications capable de produire des trous précis de haute qualité à des vitesses et des avances élevées (tolérance de trou H9). Pointe auto-centrante à 140° avec 4 facettes et une conception de goujure CTW pour un débit copeaux optimum. L'arrosage centralisé améliore l'évacuation des copeaux. Le revêtement TiAlN augmente la dureté en surface et améliore la durée de vie de l'outil.

FORCE X

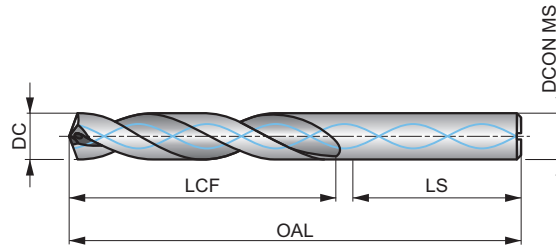

HM	DIN 6537L	5xD
140°	TiAlN	DIN 6535HA
CTW	R	Arrosage centralisé
DC m7		

Adéquation du groupe de matériaux de la pièce, valeurs de départ pour la vitesse de coupe (m/min) et code Alpha d'avance. Les tableaux d'avances par tour se trouvent à partir de la page 274.

P1.1 ■ 170V	P1.2 ■ 190V	P1.3 ■ 197V	P2.1 ■ 145V	P2.2 ■ 128V	P2.3 ■ 113V	P3.1 ■ 126V	P3.2 ■ 102V	P3.3 ■ 86V	P4.1 ■ 75V	P4.2 ■ 64V	P4.3 ■ 52U	M1.1 ▣ 71V	M1.2 ▣ 61V
M2.1 ▣ 64V	M2.2 ▣ 52V	M2.3 ▣ 44U	M3.1 ▣ 39V	M3.2 ▣ 33V	M3.3 ▣ 30V	M4.1 ▣ 29U	M4.2 ▣ 25U	K1.1 ■ 105W	K1.2 ■ 77W	K1.3 ■ 58W	K2.1 ■ 93V	K2.2 ■ 76V	K2.3 ■ 61V
K3.1 ■ 83V	K3.2 ■ 64V	K3.3 ■ 51V	K4.1 ■ 77V	K4.2 ■ 58V	K4.3 ■ 43V	K4.4 ■ 36V	K4.5 ■ 30V	K5.1 ■ 86V	K5.2 ■ 66V	K5.3 ■ 50V	N1.1 ■ 238W	N1.2 ■ 179W	N1.3 ■ 119W
N2.1 ■ 293V	N2.2 ■ 263V	N2.3 ■ 190V	N3.1 ■ 354W	N3.2 ■ 209W	N3.3 ■ 105W	S1.1 ■ 52V	S1.2 ■ 43V	S1.3 ■ 38U	H1.1 ■ 53U	H2.1 ▣ 31U	H2.2 ▣ 29U	H3.1 ▣ 35U	H3.2 ▣ 29U

DCON MS tolérance h6.

Product	DC (inch)	DC (mm)	DC (inch)	LCF (mm)	OAL (mm)	LS (mm)	DCON MS (mm)
R4533.0	–	3.00	0.1181	28.0	66.0	36.0	6.00
R4533.1	–	3.10	0.1220	28.0	66.0	36.0	6.00
R4531/8	1/8	3.18	0.1250	28.0	66.0	36.0	6.00
R4533.2	–	3.20	0.1260	28.0	66.0	36.0	6.00
R453N30	N30	3.26	0.1283	28.0	66.0	36.0	6.00
R4533.3	–	3.30	0.1299	28.0	66.0	36.0	6.00
R4533.4	–	3.40	0.1339	28.0	66.0	36.0	6.00
R453N29	N29	3.45	0.1360	28.0	66.0	36.0	6.00
R4533.5	–	3.50	0.1378	28.0	66.0	36.0	6.00
R453N28	N28	3.57	0.1406	28.0	66.0	36.0	6.00
R4539/64	9/64	3.57	0.1406	28.0	66.0	36.0	6.00
R4533.6	–	3.60	0.1417	28.0	66.0	36.0	6.00
R453N27	N27	3.66	0.1441	28.0	66.0	36.0	6.00
R4533.7	–	3.70	0.1457	28.0	66.0	36.0	6.00
R453N26	N26	3.73	0.1469	36.0	74.0	36.0	6.00
R4533.8	–	3.80	0.1496	36.0	74.0	36.0	6.00
R453N24	N24	3.86	0.1520	36.0	74.0	36.0	6.00
R4533.9	–	3.90	0.1535	36.0	74.0	36.0	6.00
R453N23	N23	3.91	0.1539	36.0	74.0	36.0	6.00
R4535/32	5/32	3.97	0.1563	36.0	74.0	36.0	6.00
R453N22	N22	3.99	0.1571	36.0	74.0	36.0	6.00
R4534.0	–	4.00	0.1575	36.0	74.0	36.0	6.00
R453N21	N21	4.04	0.1591	36.0	74.0	36.0	6.00
R4534.05	–	4.05	0.1594	36.0	74.0	36.0	6.00
R453N20	N20	4.09	0.1610	36.0	74.0	36.0	6.00

Product	DC	DC	DC	LCF	OAL	LS	DCON MS
	(inch)	(mm)	(inch)	(mm)	(mm)	(mm)	(mm)
R4534.1	–	4.10	0.1614	36.0	74.0	36.0	6.00
R4534.2	–	4.20	0.1654	36.0	74.0	36.0	6.00
R453N19	N19	4.22	0.1661	36.0	74.0	36.0	6.00
R4534.3	–	4.30	0.1693	36.0	74.0	36.0	6.00
R453N18	N18	4.31	0.1697	36.0	74.0	36.0	6.00
R45311/64	11/64	4.37	0.1719	36.0	74.0	36.0	6.00
R4534.4	–	4.40	0.1732	36.0	74.0	36.0	6.00
R4534.5	–	4.50	0.1772	36.0	74.0	36.0	6.00
R453N16	N16	4.50	0.1772	36.0	74.0	36.0	6.00
R453N15	N15	4.57	0.1799	36.0	74.0	36.0	6.00
R4534.6	–	4.60	0.1811	36.0	74.0	36.0	6.00
R453N14	N14	4.62	0.1819	36.0	74.0	36.0	6.00
R4534.7	–	4.70	0.1850	36.0	74.0	36.0	6.00
R4533/16	3/16	4.76	0.1875	44.0	82.0	36.0	6.00
R4534.8	–	4.80	0.1890	44.0	82.0	36.0	6.00
R453N12	N12	4.80	0.1890	44.0	82.0	36.0	6.00
R453N11	N11	4.85	0.1909	44.0	82.0	36.0	6.00
R4534.9	–	4.90	0.1929	44.0	82.0	36.0	6.00
R453N10	N10	4.92	0.1937	44.0	82.0	36.0	6.00
R453N9	N9	4.98	0.1961	44.0	82.0	36.0	6.00
R4535.0	–	5.00	0.1969	44.0	82.0	36.0	6.00
R4535.05	–	5.05	0.1988	44.0	82.0	36.0	6.00
R453N8	N8	5.06	0.1992	44.0	82.0	36.0	6.00
R4535.1	–	5.10	0.2008	44.0	82.0	36.0	6.00
R453N7	N7	5.11	0.2010	44.0	82.0	36.0	6.00
R45313/64	13/64	5.16	0.2031	44.0	82.0	36.0	6.00
R4535.2	–	5.20	0.2047	44.0	82.0	36.0	6.00
R453N5	N5	5.22	0.2055	44.0	82.0	36.0	6.00
R4535.3	–	5.30	0.2087	44.0	82.0	36.0	6.00
R453N4	N4	5.31	0.2091	44.0	82.0	36.0	6.00
R4535.4	–	5.40	0.2126	44.0	82.0	36.0	6.00
R453N3	N3	5.41	0.2130	44.0	82.0	36.0	6.00
R4535.5	–	5.50	0.2165	44.0	82.0	36.0	6.00
R4537/32	7/32	5.56	0.2188	44.0	82.0	36.0	6.00
R4535.6	–	5.60	0.2205	44.0	82.0	36.0	6.00
R453N2	N2	5.61	0.2209	44.0	82.0	36.0	6.00
R4535.7	–	5.70	0.2244	44.0	82.0	36.0	6.00
R453N1	N1	5.79	0.2280	44.0	82.0	36.0	6.00
R4535.8	–	5.80	0.2283	44.0	82.0	36.0	6.00
R4535.9	–	5.90	0.2323	44.0	82.0	36.0	6.00
R453A	A	5.94	0.2339	44.0	82.0	36.0	6.00
R45315/64	15/64	5.95	0.2344	44.0	82.0	36.0	6.00
R4536.0	–	6.00	0.2362	44.0	82.0	36.0	6.00
R453B	B	6.05	0.2380	53.0	91.0	36.0	8.00
R4536.05	–	6.05	0.2382	53.0	91.0	36.0	8.00
R4536.1	–	6.10	0.2402	53.0	91.0	36.0	8.00
R453C	C	6.15	0.2421	53.0	91.0	36.0	8.00
R4536.2	–	6.20	0.2441	53.0	91.0	36.0	8.00
R453D	D	6.25	0.2461	53.0	91.0	36.0	8.00
R4536.3	–	6.30	0.2480	53.0	91.0	36.0	8.00
R4531/4	1/4	6.35	0.2500	53.0	91.0	36.0	8.00
R4536.4	–	6.40	0.2520	53.0	91.0	36.0	8.00
R4536.5	–	6.50	0.2559	53.0	91.0	36.0	8.00
R453F	F	6.53	0.2571	53.0	91.0	36.0	8.00
R4536.6	–	6.60	0.2598	53.0	91.0	36.0	8.00
R453G	G	6.63	0.2610	53.0	91.0	36.0	8.00
R4536.7	–	6.70	0.2638	53.0	91.0	36.0	8.00
R45317/64	17/64	6.75	0.2656	53.0	91.0	36.0	8.00
R4536.8	–	6.80	0.2677	53.0	91.0	36.0	8.00
R4536.9	–	6.90	0.2717	53.0	91.0	36.0	8.00
R453I	I	6.91	0.2720	53.0	91.0	36.0	8.00
R4537.0	–	7.00	0.2756	53.0	91.0	36.0	8.00

Product	DC	DC	DC	LCF	OAL	LS	DCON MS
	(inch)	(mm)	(inch)	(mm)	(mm)	(mm)	(mm)
R453J	J	7.04	0.2772	53.0	91.0	36.0	8.00
R4537.1	–	7.10	0.2795	53.0	91.0	36.0	8.00
R453K	K	7.14	0.2811	53.0	91.0	36.0	8.00
R4539/32	9/32	7.14	0.2813	53.0	91.0	36.0	8.00
R4537.2	–	7.20	0.2835	53.0	91.0	36.0	8.00
R4537.3	–	7.30	0.2874	53.0	91.0	36.0	8.00
R453L	L	7.37	0.2902	53.0	91.0	36.0	8.00
R4537.4	–	7.40	0.2913	53.0	91.0	36.0	8.00
R453M	M	7.49	0.2949	53.0	91.0	36.0	8.00
R4537.5	–	7.50	0.2953	53.0	91.0	36.0	8.00
R45319/64	19/64	7.54	0.2969	53.0	91.0	36.0	8.00
R4537.6	–	7.60	0.2992	53.0	91.0	36.0	8.00
R453N	N	7.67	0.3020	53.0	91.0	36.0	8.00
R4537.7	–	7.70	0.3031	53.0	91.0	36.0	8.00
R4537.8	–	7.80	0.3071	53.0	91.0	36.0	8.00
R4537.9	–	7.90	0.3110	53.0	91.0	36.0	8.00
R4535/16	5/16	7.94	0.3125	53.0	91.0	36.0	8.00
R4538.0	–	8.00	0.3150	53.0	91.0	36.0	8.00
R4530	O	8.03	0.3161	61.0	103.0	40.0	10.00
R4538.05	–	8.05	0.3169	61.0	103.0	40.0	10.00
R4538.1	–	8.10	0.3189	61.0	103.0	40.0	10.00
R4538.2	–	8.20	0.3228	61.0	103.0	40.0	10.00
R453P	P	8.20	0.3228	61.0	103.0	40.0	10.00
R4538.3	–	8.30	0.3268	61.0	103.0	40.0	10.00
R45321/64	21/64	8.33	0.3281	61.0	103.0	40.0	10.00
R4538.4	–	8.40	0.3307	61.0	103.0	40.0	10.00
R453Q	Q	8.43	0.3319	61.0	103.0	40.0	10.00
R4538.5	–	8.50	0.3346	61.0	103.0	40.0	10.00
R4538.6	–	8.60	0.3386	61.0	103.0	40.0	10.00
R453R	R	8.61	0.3390	61.0	103.0	40.0	10.00
R4538.7	–	8.70	0.3425	61.0	103.0	40.0	10.00
R45311/32	11/32	8.73	0.3438	61.0	103.0	40.0	10.00
R4538.8	–	8.80	0.3465	61.0	103.0	40.0	10.00
R453S	S	8.84	0.3480	61.0	103.0	40.0	10.00
R4538.9	–	8.90	0.3504	61.0	103.0	40.0	10.00
R4539.0	–	9.00	0.3543	61.0	103.0	40.0	10.00
R4539.1	–	9.10	0.3583	61.0	103.0	40.0	10.00
R45323/64	23/64	9.13	0.3594	61.0	103.0	40.0	10.00
R4539.2	–	9.20	0.3622	61.0	103.0	40.0	10.00
R4539.3	–	9.30	0.3661	61.0	103.0	40.0	10.00
R453U	U	9.35	0.3681	61.0	103.0	40.0	10.00
R4539.4	–	9.40	0.3701	61.0	103.0	40.0	10.00
R4539.5	–	9.50	0.3740	61.0	103.0	40.0	10.00
R4533/8	3/8	9.53	0.3750	61.0	103.0	40.0	10.00
R4539.6	–	9.60	0.3780	61.0	103.0	40.0	10.00
R4539.7	–	9.70	0.3819	61.0	103.0	40.0	10.00
R4539.8	–	9.80	0.3858	61.0	103.0	40.0	10.00
R453W	W	9.80	0.3858	61.0	103.0	40.0	10.00
R4539.9	–	9.90	0.3898	61.0	103.0	40.0	10.00
R45325/64	25/64	9.92	0.3906	61.0	103.0	40.0	10.00
R45310.0	–	10.00	0.3937	61.0	103.0	40.0	10.00
R45310.05	–	10.05	0.3957	70.0	118.0	45.0	12.00
R453X	X	10.08	0.3969	70.0	118.0	45.0	12.00
R45310.1	–	10.10	0.3976	70.0	118.0	45.0	12.00
R45310.2	–	10.20	0.4016	70.0	118.0	45.0	12.00
R453Y	Y	10.26	0.4039	70.0	118.0	45.0	12.00
R45310.3	–	10.30	0.4055	70.0	118.0	45.0	12.00
R45313/32	13/32	10.32	0.4063	70.0	118.0	45.0	12.00
R45310.4	–	10.40	0.4094	70.0	118.0	45.0	12.00
R45310.5	–	10.50	0.4134	70.0	118.0	45.0	12.00
R45310.6	–	10.60	0.4173	70.0	118.0	45.0	12.00
R45327/64	27/64	10.72	0.4219	70.0	118.0	45.0	12.00

Product	DC	DC	DC	LCF	OAL	LS	DCON MS
	(inch)	(mm)	(inch)	(mm)	(mm)	(mm)	(mm)
R45310.8	–	10.80	0.4252	70.0	118.0	45.0	12.00
R45311.0	–	11.00	0.4331	70.0	118.0	45.0	12.00
R4537/16	7/16	11.11	0.4375	70.0	118.0	45.0	12.00
R45311.2	–	11.20	0.4409	70.0	118.0	45.0	12.00
R45311.3	–	11.30	0.4449	70.0	118.0	45.0	12.00
R45311.4	–	11.40	0.4488	70.0	118.0	45.0	12.00
R45311.5	–	11.50	0.4528	70.0	118.0	45.0	12.00
R45329/64	29/64	11.51	0.4531	70.0	118.0	45.0	12.00
R45311.6	–	11.60	0.4567	70.0	118.0	45.0	12.00
R45311.8	–	11.80	0.4646	70.0	118.0	45.0	12.00
R45315/32	15/32	11.91	0.4688	70.0	118.0	45.0	12.00
R45312.0	–	12.00	0.4724	70.0	118.0	45.0	12.00
R45312.05	–	12.05	0.4744	76.0	124.0	45.0	14.00
R45312.2	–	12.20	0.4803	76.0	124.0	45.0	14.00
R45331/64	31/64	12.30	0.4844	76.0	124.0	45.0	14.00
R45312.5	–	12.50	0.4921	76.0	124.0	45.0	14.00
R45312.7	–	12.70	0.5000	76.0	124.0	45.0	14.00
R4531/2	1/2	12.70	0.5000	76.0	124.0	45.0	14.00
R45312.8	–	12.80	0.5039	76.0	124.0	45.0	14.00
R45313.0	–	13.00	0.5118	76.0	124.0	45.0	14.00
R45333/64	33/64	13.10	0.5156	76.0	124.0	45.0	14.00
R45313.3	–	13.30	0.5236	76.0	124.0	45.0	14.00
R45317/32	17/32	13.49	0.5313	76.0	124.0	45.0	14.00
R45313.5	–	13.50	0.5315	76.0	124.0	45.0	14.00
R45313.8	–	13.80	0.5433	76.0	124.0	45.0	14.00
R45335/64	35/64	13.89	0.5469	76.0	124.0	45.0	14.00
R45314.0	–	14.00	0.5512	76.0	124.0	45.0	14.00
R45314.25	–	14.25	0.5610	82.0	133.0	48.0	16.00
R4539/16	9/16	14.29	0.5625	82.0	133.0	48.0	16.00
R45314.5	–	14.50	0.5709	82.0	133.0	48.0	16.00
R45337/64	37/64	14.68	0.5781	82.0	133.0	48.0	16.00
R45314.8	–	14.80	0.5827	82.0	133.0	48.0	16.00
R45315.0	–	15.00	0.5906	82.0	133.0	48.0	16.00
R45319/32	19/32	15.08	0.5938	82.0	133.0	48.0	16.00
R45315.1	–	15.10	0.5945	82.0	133.0	48.0	16.00
R45315.3	–	15.30	0.6024	82.0	133.0	48.0	16.00
R45315.5	–	15.50	0.6102	82.0	133.0	48.0	16.00
R45315.8	–	15.80	0.6220	82.0	133.0	48.0	16.00
R4535/8	5/8	15.88	0.6250	82.0	133.0	48.0	16.00
R45316.0	–	16.00	0.6299	82.0	133.0	48.0	16.00
R45341/64	41/64	16.27	0.6406	91.0	143.0	48.0	18.00
R45316.5	–	16.50	0.6496	91.0	143.0	48.0	18.00
R45321/32	21/32	16.67	0.6563	91.0	143.0	48.0	18.00
R45317.0	–	17.00	0.6693	91.0	143.0	48.0	18.00
R45343/64	43/64	17.07	0.6720	91.0	143.0	48.0	18.00
R45311/16	11/16	17.46	0.6874	91.0	143.0	48.0	18.00
R45317.5	–	17.50	0.6890	91.0	143.0	48.0	18.00
R45317.8	–	17.80	0.7008	91.0	143.0	48.0	18.00
R45345/64	45/64	17.86	0.7031	91.0	143.0	48.0	18.00
R45318.0	–	18.00	0.7087	91.0	143.0	48.0	18.00
R45323/32	23/32	18.26	0.7189	99.0	153.0	50.0	20.00
R45318.5	–	18.50	0.7283	99.0	153.0	50.0	20.00
R45347/64	47/64	18.65	0.7343	99.0	153.0	50.0	20.00
R45319.0	–	19.00	0.7480	99.0	153.0	50.0	20.00
R4533/4	3/4	19.05	0.7500	99.0	153.0	50.0	20.00
R45319.5	–	19.50	0.7677	99.0	153.0	50.0	20.00
R45319.8	–	19.80	0.7795	99.0	153.0	50.0	20.00
R45320.0	–	20.00	0.7874	99.0	153.0	50.0	20.00

R459



Foret carbure monobloc FORCE X longueur 8xD avec arrosage centralisé, revêtement TiAlN

Foret haute performance multi-applications capable de produire des trous précis de haute qualité à des vitesses et des avances élevées (tolérance de trou H9). Pointe auto-centrante à 140° avec 4 facettes et une conception de goujure CTW pour un débit copeaux optimum. L'arrosage centralisé améliore l'évacuation des copeaux. Le revêtement TiAlN augmente la dureté en surface et améliore la durée de vie de l'outil.

FORCE X

HM	DORMER	8xD
140°	TiAlN	DIN 6535HA
CTW	R	
DC m7		

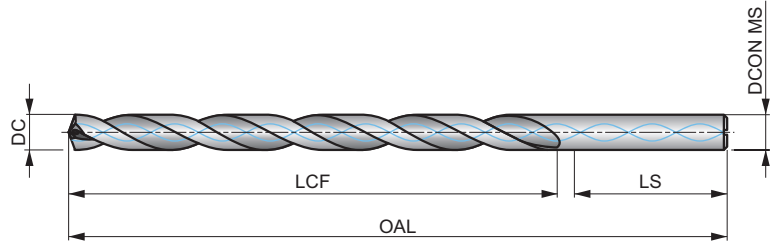

Adéquation du groupe de matériaux de la pièce, valeurs de départ pour la vitesse de coupe (m/min) et code Alpha d'avance. Les tableaux d'avances par tour se trouvent à partir de la page 274.

P1.1 ■ 143 V	P1.2 ■ 160 V	P1.3 ■ 166 V	P2.1 ■ 122 V	P2.2 ■ 108 U	P2.3 ■ 95 U	P3.1 ■ 106 U	P3.2 ■ 86 U	P3.3 ■ 72 U	P4.1 ■ 63 U	P4.2 ■ 54 U	P4.3 ■ 44 T	M1.1 ▣ 60 V	M1.2 ▣ 51 V
M2.1 ▣ 54 V	M2.2 ▣ 44 V	M2.3 ▣ 37 U	M3.1 ▣ 33 V	M3.2 ▣ 28 V	M3.3 ▣ 26 V	M4.1 ▣ 24 U	M4.2 ▣ 21 U	K1.1 ■ 88 W	K1.2 ■ 65 W	K1.3 ■ 49 W	K2.1 ■ 78 V	K2.2 ■ 64 V	K2.3 ■ 51 V
K3.1 ■ 70 V	K3.2 ■ 54 V	K3.3 ■ 43 V	K4.1 ■ 65 V	K4.2 ■ 49 V	K4.3 ■ 36 V	K4.4 ■ 30 V	K4.5 ■ 26 V	K5.1 ■ 73 V	K5.2 ■ 55 V	K5.3 ■ 42 V	N1.1 ▣ 1200 W	N1.2 ▣ 150 W	N1.3 ■ 100 W
N2.1 ■ 246 V	N2.2 ■ 222 V	N2.3 ■ 160 V	N3.1 ▣ 298 V	N3.2 ▣ 176 V	N3.3 ▣ 88 V								

DCON MS tolérance h6.

Product	DC (inch)	DC (mm)	DC (inch)	LCF (mm)	OAL (mm)	LS (mm)	DCON MS (mm)
R4593.0	–	3.00	0.1181	37.0	79.0	36.0	6.00
R4593.1	–	3.10	0.1220	37.0	79.0	36.0	6.00
R4591/8	1/8	3.18	0.1250	37.0	79.0	36.0	6.00
R4593.2	–	3.20	0.1260	37.0	79.0	36.0	6.00
R4593.3	–	3.30	0.1299	37.0	79.0	36.0	6.00
R4593.4	–	3.40	0.1339	37.0	79.0	36.0	6.00
R4593.5	–	3.50	0.1378	37.0	79.0	36.0	6.00
R4599/64	9/64	3.57	0.1406	37.0	79.0	36.0	6.00
R4593.6	–	3.60	0.1417	37.0	79.0	36.0	6.00
R4593.7	–	3.70	0.1457	37.0	79.0	36.0	6.00
R4593.8	–	3.80	0.1496	48.0	90.0	36.0	6.00
R4593.9	–	3.90	0.1535	48.0	90.0	36.0	6.00
R4595/32	5/32	3.97	0.1563	48.0	90.0	36.0	6.00
R4594.0	–	4.00	0.1575	48.0	90.0	36.0	6.00
R4594.1	–	4.10	0.1614	48.0	90.0	36.0	6.00
R4594.2	–	4.20	0.1654	48.0	90.0	36.0	6.00
R4594.3	–	4.30	0.1693	48.0	90.0	36.0	6.00
R45911/64	11/64	4.37	0.1719	48.0	90.0	36.0	6.00
R4594.4	–	4.40	0.1732	48.0	90.0	36.0	6.00
R4594.5	–	4.50	0.1772	48.0	90.0	36.0	6.00
R4594.6	–	4.60	0.1811	48.0	90.0	36.0	6.00
R4594.7	–	4.70	0.1850	62.0	104.0	36.0	6.00
R4593/16	3/16	4.76	0.1875	62.0	104.0	36.0	6.00
R4594.8	–	4.80	0.1890	62.0	104.0	36.0	6.00
R4594.9	–	4.90	0.1929	62.0	104.0	36.0	6.00

Product	DC	DC	DC	LCF	OAL	LS	DCON MS
	(inch)	(mm)	(inch)	(mm)	(mm)	(mm)	(mm)
R4595.0	–	5.00	0.1969	62.0	104.0	36.0	6.00
R4595.1	–	5.10	0.2008	62.0	104.0	36.0	6.00
R45913/64	13/64	5.16	0.2031	62.0	104.0	36.0	6.00
R4595.2	–	5.20	0.2047	62.0	104.0	36.0	6.00
R4595.3	–	5.30	0.2087	62.0	104.0	36.0	6.00
R4595.4	–	5.40	0.2126	62.0	104.0	36.0	6.00
R4595.5	–	5.50	0.2165	62.0	104.0	36.0	6.00
R4597/32	7/32	5.56	0.2188	62.0	104.0	36.0	6.00
R4595.6	–	5.60	0.2205	62.0	104.0	36.0	6.00
R4595.7	–	5.70	0.2244	62.0	104.0	36.0	6.00
R4595.8	–	5.80	0.2283	62.0	104.0	36.0	6.00
R4595.9	–	5.90	0.2323	62.0	104.0	36.0	6.00
R45915/64	15/64	5.95	0.2344	62.0	104.0	36.0	6.00
R4596.0	–	6.00	0.2362	62.0	104.0	36.0	6.00
R4596.1	–	6.10	0.2402	84.0	126.0	36.0	8.00
R4596.2	–	6.20	0.2441	84.0	126.0	36.0	8.00
R4596.3	–	6.30	0.2480	84.0	126.0	36.0	8.00
R4591/4	1/4	6.35	0.2500	84.0	126.0	36.0	8.00
R4596.4	–	6.40	0.2520	84.0	126.0	36.0	8.00
R4596.5	–	6.50	0.2559	84.0	126.0	36.0	8.00
R4596.6	–	6.60	0.2598	84.0	126.0	36.0	8.00
R4596.7	–	6.70	0.2638	84.0	126.0	36.0	8.00
R45917/64	17/64	6.75	0.2656	84.0	126.0	36.0	8.00
R4596.8	–	6.80	0.2677	84.0	126.0	36.0	8.00
R4596.9	–	6.90	0.2717	84.0	126.0	36.0	8.00
R4597.0	–	7.00	0.2756	84.0	126.0	36.0	8.00
R4597.1	–	7.10	0.2795	84.0	126.0	36.0	8.00
R4599/32	9/32	7.14	0.2813	84.0	126.0	36.0	8.00
R4597.2	–	7.20	0.2835	84.0	126.0	36.0	8.00
R4597.3	–	7.30	0.2874	84.0	126.0	36.0	8.00
R4597.4	–	7.40	0.2913	84.0	126.0	36.0	8.00
R4597.5	–	7.50	0.2953	84.0	126.0	36.0	8.00
R45919/64	19/64	7.54	0.2969	84.0	126.0	36.0	8.00
R4597.6	–	7.60	0.2992	84.0	126.0	36.0	8.00
R4597.7	–	7.70	0.3031	84.0	126.0	36.0	8.00
R4597.8	–	7.80	0.3071	84.0	126.0	36.0	8.00
R4597.9	–	7.90	0.3110	84.0	126.0	36.0	8.00
R4595/16	5/16	7.94	0.3125	84.0	126.0	36.0	8.00
R4598.0	–	8.00	0.3150	84.0	126.0	36.0	8.00
R4598.1	–	8.10	0.3189	106.0	152.0	40.0	10.00
R4598.2	–	8.20	0.3228	106.0	152.0	40.0	10.00
R4598.3	–	8.30	0.3268	106.0	152.0	40.0	10.00
R45921/64	21/64	8.33	0.3281	106.0	152.0	40.0	10.00
R4598.4	–	8.40	0.3307	106.0	152.0	40.0	10.00
R4598.5	–	8.50	0.3346	106.0	152.0	40.0	10.00
R4598.6	–	8.60	0.3386	106.0	152.0	40.0	10.00
R4598.7	–	8.70	0.3425	106.0	152.0	40.0	10.00
R45911/32	11/32	8.73	0.3438	106.0	152.0	40.0	10.00
R4598.8	–	8.80	0.3465	106.0	152.0	40.0	10.00
R4598.9	–	8.90	0.3504	106.0	152.0	40.0	10.00
R4599.0	–	9.00	0.3543	106.0	152.0	40.0	10.00
R4599.1	–	9.10	0.3583	106.0	152.0	40.0	10.00
R45923/64	23/64	9.13	0.3594	106.0	152.0	40.0	10.00
R4599.2	–	9.20	0.3622	106.0	152.0	40.0	10.00
R4599.3	–	9.30	0.3661	106.0	152.0	40.0	10.00
R4599.4	–	9.40	0.3701	106.0	152.0	40.0	10.00
R4599.5	–	9.50	0.3740	106.0	152.0	40.0	10.00
R4593/8	3/8	9.53	0.3750	106.0	152.0	40.0	10.00
R4599.6	–	9.60	0.3780	106.0	152.0	40.0	10.00
R4599.7	–	9.70	0.3819	106.0	152.0	40.0	10.00
R4599.8	–	9.80	0.3858	106.0	152.0	40.0	10.00
R4599.9	–	9.90	0.3898	106.0	152.0	40.0	10.00

Product	DC	DC	DC	LCF	OAL	LS	DCON MS
	(inch)	(mm)	(inch)	(mm)	(mm)	(mm)	(mm)
R45925/64	25/64	9.92	0.3906	106.0	152.0	40.0	10.00
R45910.0	–	10.00	0.3937	106.0	152.0	40.0	10.00
R45910.2	–	10.20	0.4016	128.0	180.0	45.0	12.00
R45910.3	–	10.30	0.4055	128.0	180.0	45.0	12.00
R45913/32	13/32	10.32	0.4063	128.0	180.0	45.0	12.00
R45910.4	–	10.40	0.4094	128.0	180.0	45.0	12.00
R45910.5	–	10.50	0.4134	128.0	180.0	45.0	12.00
R45927/64	27/64	10.72	0.4219	128.0	180.0	45.0	12.00
R45910.8	–	10.80	0.4252	128.0	180.0	45.0	12.00
R45911.0	–	11.00	0.4331	128.0	180.0	45.0	12.00
R4597/16	7/16	11.11	0.4375	128.0	180.0	45.0	12.00
R45911.2	–	11.20	0.4409	128.0	180.0	45.0	12.00
R45911.3	–	11.30	0.4449	128.0	180.0	45.0	12.00
R45911.5	–	11.50	0.4528	128.0	180.0	45.0	12.00
R45929/64	29/64	11.51	0.4531	128.0	180.0	45.0	12.00
R45911.8	–	11.80	0.4646	128.0	180.0	45.0	12.00
R45915/32	15/32	11.91	0.4688	128.0	180.0	45.0	12.00
R45912.0	–	12.00	0.4724	128.0	180.0	45.0	12.00
R45912.2	–	12.20	0.4803	151.0	202.0	48.0	14.00
R45931/64	31/64	12.30	0.4844	151.0	202.0	48.0	14.00
R45912.5	–	12.50	0.4921	151.0	202.0	48.0	14.00
R4591/2	1/2	12.70	0.5000	151.0	202.0	48.0	14.00
R45912.8	–	12.80	0.5039	151.0	202.0	48.0	14.00
R45913.0	–	13.00	0.5118	151.0	202.0	48.0	14.00
R45933/64	33/64	13.10	0.5156	151.0	202.0	48.0	14.00
R45917/32	17/32	13.49	0.5313	151.0	202.0	48.0	14.00
R45913.5	–	13.50	0.5315	151.0	202.0	48.0	14.00
R45935/64	35/64	13.89	0.5469	151.0	202.0	48.0	14.00
R45914.0	–	14.00	0.5512	151.0	202.0	48.0	14.00
R45914.25	–	14.25	0.5610	172.0	227.0	48.0	16.00
R4599/16	9/16	14.29	0.5625	172.0	227.0	48.0	16.00
R45914.5	–	14.50	0.5709	172.0	227.0	48.0	16.00
R45937/64	37/64	14.68	0.5781	172.0	227.0	48.0	16.00
R45915.0	–	15.00	0.5906	172.0	227.0	48.0	16.00
R45919/32	19/32	15.08	0.5938	172.0	227.0	48.0	16.00
R45915.1	–	15.10	0.5945	172.0	227.0	48.0	16.00
R45915.5	–	15.50	0.6102	172.0	227.0	48.0	16.00
R4595/8	5/8	15.88	0.6250	172.0	227.0	48.0	16.00
R45916.0	–	16.00	0.6299	172.0	227.0	48.0	16.00

R467

DORMER

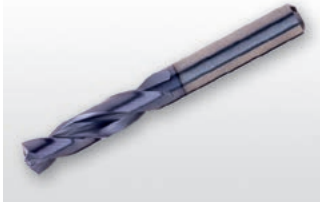

Foret carbure monobloc FORCE M longueur 3xD avec arrosage centralisé, revêtement TiAIN

Foret haute performance capable de produire des trous précis de haute qualité à des vitesses et des avances élevées (tolérance de trou H9 dans les aciers inoxydables et les matériaux réfractaires). Pointe auto-centrante à 140° avec 4 facettes et une conception de goujure CTW. L'arrosage centralisé améliore l'évacuation des copeaux. Le revêtement TiAIN augmente la dureté en surface et améliore la durée de vie de l'outil.

FORCE M

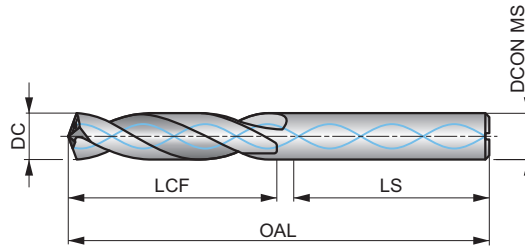

HM	DIN 6537K	3xD
140°	TiAIN	DIN 6535HA
CTW	R	
DC m7		

Adéquation du groupe de matériaux de la pièce, valeurs de départ pour la vitesse de coupe (m/min) et code Alpha d'avance. Les tableaux d'avances par tour se trouvent à partir de la page 274.

M1.1 ■ 117 G	M1.2 ■ 99 G	M2.1 ■ 104 G	M2.2 ■ 85 G	M2.3 ■ 71 E	M3.1 ■ 87 G	M3.2 ■ 75 G	M3.3 ■ 68 F	M4.1 ■ 60 F	M4.2 ■ 52 E	S1.1 ■ 55 V	S1.2 ■ 45 V	S1.3 ■ 40 U	S2.1 ■ 60 U
S2.2 ■ 56 U	S3.1 ■ 45 U	S3.2 ■ 40 U	S4.1 ■ 35 U	S4.2 ■ 32 U									

DCON MS tolérance h6.

Product	DC (inch)	DC (mm)	DC (inch)	LCF (mm)	OAL (mm)	LS (mm)	DCON MS (mm)
R4673.0	–	3.00	0.1181	20.0	62.0	36.0	6.00
R4673.1	–	3.10	0.1220	20.0	62.0	36.0	6.00
R4671/8	1/8	3.18	0.1250	20.0	62.0	36.0	6.00
R4673.2	–	3.20	0.1260	20.0	62.0	36.0	6.00
R4673.3	–	3.30	0.1299	20.0	62.0	36.0	6.00
R4673.4	–	3.40	0.1339	20.0	62.0	36.0	6.00
R467N29	N29	3.45	0.1360	20.0	62.0	36.0	6.00
R4673.5	–	3.50	0.1378	20.0	62.0	36.0	6.00
R4679/64	9/64	3.57	0.1406	20.0	62.0	36.0	6.00
R4673.6	–	3.60	0.1417	20.0	62.0	36.0	6.00
R4673.7	–	3.70	0.1457	20.0	62.0	36.0	6.00
R4673.8	–	3.80	0.1496	24.0	66.0	36.0	6.00
R4673.9	–	3.90	0.1535	24.0	66.0	36.0	6.00
R4675/32	5/32	3.97	0.1563	24.0	66.0	36.0	6.00
R4674.0	–	4.00	0.1575	24.0	66.0	36.0	6.00
R4674.05	–	4.05	0.1594	24.0	66.0	36.0	6.00
R4674.1	–	4.10	0.1614	24.0	66.0	36.0	6.00
R4674.2	–	4.20	0.1654	24.0	66.0	36.0	6.00
R4674.3	–	4.30	0.1693	24.0	66.0	36.0	6.00
R46711/64	11/64	4.37	0.1719	24.0	66.0	36.0	6.00
R4674.4	–	4.40	0.1732	24.0	66.0	36.0	6.00
R4674.5	–	4.50	0.1772	24.0	66.0	36.0	6.00
R4674.6	–	4.60	0.1811	24.0	66.0	36.0	6.00
R4674.7	–	4.70	0.1850	24.0	66.0	36.0	6.00
R4673/16	3/16	4.76	0.1875	28.0	66.0	36.0	6.00
R4674.8	–	4.80	0.1890	28.0	66.0	36.0	6.00
R4674.9	–	4.90	0.1929	28.0	66.0	36.0	6.00
R4675.0	–	5.00	0.1969	28.0	66.0	36.0	6.00
R4675.05	–	5.05	0.1988	28.0	66.0	36.0	6.00

Product	DC	DC	DC	LCF	OAL	LS	DCON MS
	(inch)	(mm)	(inch)	(mm)	(mm)	(mm)	(mm)
R4675.1	–	5.10	0.2008	28.0	66.0	36.0	6.00
R467N7	N7	5.11	0.2010	28.0	66.0	36.0	6.00
R46713/64	13/64	5.16	0.2031	28.0	66.0	36.0	6.00
R4675.2	–	5.20	0.2047	28.0	66.0	36.0	6.00
R467N5	N5	5.22	0.2055	28.0	66.0	36.0	6.00
R4675.3	–	5.30	0.2087	28.0	66.0	36.0	6.00
R4675.4	–	5.40	0.2126	28.0	66.0	36.0	6.00
R4675.5	–	5.50	0.2165	28.0	66.0	36.0	6.00
R4677/32	7/32	5.56	0.2188	28.0	66.0	36.0	6.00
R4675.6	–	5.60	0.2205	28.0	66.0	36.0	6.00
R4675.7	–	5.70	0.2244	28.0	66.0	36.0	6.00
R4675.8	–	5.80	0.2283	28.0	66.0	36.0	6.00
R4675.9	–	5.90	0.2323	28.0	66.0	36.0	6.00
R46715/64	15/64	5.95	0.2344	28.0	66.0	36.0	6.00
R4676.0	–	6.00	0.2362	28.0	66.0	36.0	6.00
R4676.05	–	6.05	0.2382	34.0	79.0	36.0	8.00
R4676.1	–	6.10	0.2402	34.0	79.0	36.0	8.00
R4676.2	–	6.20	0.2441	34.0	79.0	36.0	8.00
R4676.3	–	6.30	0.2480	34.0	79.0	36.0	8.00
R4671/4	1/4	6.35	0.2500	34.0	79.0	36.0	8.00
R4676.4	–	6.40	0.2520	34.0	79.0	36.0	8.00
R4676.5	–	6.50	0.2559	34.0	79.0	36.0	8.00
R4676.6	–	6.60	0.2598	34.0	79.0	36.0	8.00
R4676.7	–	6.70	0.2638	34.0	79.0	36.0	8.00
R46717/64	17/64	6.75	0.2656	34.0	79.0	36.0	8.00
R4676.8	–	6.80	0.2677	34.0	79.0	36.0	8.00
R4676.9	–	6.90	0.2717	34.0	79.0	36.0	8.00
R4677.0	–	7.00	0.2756	34.0	79.0	36.0	8.00
R4677.1	–	7.10	0.2795	41.0	79.0	36.0	8.00
R4679/32	9/32	7.14	0.2813	41.0	79.0	36.0	8.00
R4677.2	–	7.20	0.2835	41.0	79.0	36.0	8.00
R4677.3	–	7.30	0.2874	41.0	79.0	36.0	8.00
R4677.4	–	7.40	0.2913	41.0	79.0	36.0	8.00
R4677.5	–	7.50	0.2953	41.0	79.0	36.0	8.00
R46719/64	19/64	7.54	0.2969	41.0	79.0	36.0	8.00
R4677.6	–	7.60	0.2992	41.0	79.0	36.0	8.00
R4677.7	–	7.70	0.3031	41.0	79.0	36.0	8.00
R4677.8	–	7.80	0.3071	41.0	79.0	36.0	8.00
R4675/16	5/16	7.94	0.3125	41.0	79.0	36.0	8.00
R4678.0	–	8.00	0.3150	41.0	79.0	36.0	8.00
R4678.05	–	8.05	0.3169	47.0	89.0	40.0	10.00
R4678.1	–	8.10	0.3189	47.0	89.0	40.0	10.00
R4678.2	–	8.20	0.3228	47.0	89.0	40.0	10.00
R4678.3	–	8.30	0.3268	47.0	89.0	40.0	10.00
R4678.4	–	8.40	0.3307	47.0	89.0	40.0	10.00
R4678.5	–	8.50	0.3346	47.0	89.0	40.0	10.00
R4678.6	–	8.60	0.3386	47.0	89.0	40.0	10.00
R4678.7	–	8.70	0.3425	47.0	89.0	40.0	10.00
R46711/32	11/32	8.73	0.3438	47.0	89.0	40.0	10.00
R4678.8	–	8.80	0.3465	47.0	89.0	40.0	10.00
R4678.9	–	8.90	0.3504	47.0	89.0	40.0	10.00
R4679.0	–	9.00	0.3543	47.0	89.0	40.0	10.00
R4679.1	–	9.10	0.3583	47.0	89.0	40.0	10.00
R46723/64	23/64	9.13	0.3594	47.0	89.0	40.0	10.00
R4679.3	–	9.30	0.3661	47.0	89.0	40.0	10.00
R4679.4	–	9.40	0.3701	47.0	89.0	40.0	10.00
R4679.5	–	9.50	0.3740	47.0	89.0	40.0	10.00
R4673/8	3/8	9.53	0.3750	47.0	89.0	40.0	10.00
R4679.6	–	9.60	0.3780	47.0	89.0	40.0	10.00
R4679.7	–	9.70	0.3819	47.0	89.0	40.0	10.00
R4679.8	–	9.80	0.3858	47.0	89.0	40.0	10.00
R4679.9	–	9.90	0.3898	47.0	89.0	40.0	10.00



Product	DC	DC	DC	LCF	OAL	LS	DCON MS
	(inch)	(mm)	(inch)	(mm)	(mm)	(mm)	(mm)
R46725/64	25/64	9.92	0.3906	47.0	89.0	40.0	10.00
R46710.0	–	10.00	0.3937	47.0	89.0	40.0	10.00
R46710.05	–	10.05	0.3957	55.0	102.0	45.0	12.00
R46710.1	–	10.10	0.3976	55.0	102.0	45.0	12.00
R46710.2	–	10.20	0.4016	55.0	102.0	45.0	12.00
R46710.3	–	10.30	0.4055	55.0	102.0	45.0	12.00
R46713/32	13/32	10.32	0.4063	55.0	102.0	45.0	12.00
R46710.4	–	10.40	0.4094	55.0	102.0	45.0	12.00
R46710.5	–	10.50	0.4134	55.0	102.0	45.0	12.00
R46710.6	–	10.60	0.4173	55.0	102.0	45.0	12.00
R46727/64	27/64	10.72	0.4219	55.0	102.0	45.0	12.00
R46710.9	–	10.90	0.4291	55.0	102.0	45.0	12.00
R46711.0	–	11.00	0.4331	55.0	102.0	45.0	12.00
R4677/16	7/16	11.11	0.4375	55.0	102.0	45.0	12.00
R46711.2	–	11.20	0.4409	55.0	102.0	45.0	12.00
R46711.4	–	11.40	0.4488	55.0	102.0	45.0	12.00
R46711.5	–	11.50	0.4528	55.0	102.0	45.0	12.00
R46729/64	29/64	11.51	0.4531	55.0	102.0	45.0	12.00
R46711.8	–	11.80	0.4646	55.0	102.0	45.0	12.00
R46715/32	15/32	11.91	0.4688	55.0	102.0	45.0	12.00
R46712.0	–	12.00	0.4724	55.0	102.0	45.0	12.00
R46712.05	–	12.05	0.4744	60.0	107.0	45.0	14.00
R46712.1	–	12.10	0.4764	60.0	107.0	45.0	14.00
R46712.2	–	12.20	0.4803	60.0	107.0	45.0	14.00
R46731/64	31/64	12.30	0.4844	60.0	107.0	45.0	14.00
R46712.5	–	12.50	0.4921	60.0	107.0	45.0	14.00
R46712.7	–	12.70	0.5000	60.0	107.0	45.0	14.00
R4671/2	1/2	12.70	0.5000	60.0	107.0	45.0	14.00
R46713.0	–	13.00	0.5118	60.0	107.0	45.0	14.00
R46733/64	33/64	13.10	0.5156	60.0	107.0	45.0	14.00
R46717/32	17/32	13.49	0.5313	60.0	107.0	45.0	14.00
R46713.5	–	13.50	0.5315	60.0	107.0	45.0	14.00
R46735/64	35/64	13.89	0.5469	60.0	107.0	45.0	14.00
R46714.0	–	14.00	0.5512	60.0	107.0	45.0	14.00
R46714.25	–	14.25	0.5610	65.0	115.0	48.0	16.00
R4679/16	9/16	14.29	0.5625	65.0	115.0	48.0	16.00
R46714.5	–	14.50	0.5709	65.0	115.0	48.0	16.00
R46737/64	37/64	14.68	0.5781	65.0	115.0	48.0	16.00
R46715.0	–	15.00	0.5906	65.0	115.0	48.0	16.00
R46719/32	19/32	15.08	0.5938	65.0	115.0	48.0	16.00
R46715.1	–	15.10	0.5945	65.0	115.0	48.0	16.00
R46715.3	–	15.30	0.6024	65.0	115.0	48.0	16.00
R46715.5	–	15.50	0.6102	65.0	115.0	48.0	16.00
R4675/8	5/8	15.88	0.6250	65.0	115.0	48.0	16.00
R46716.0	–	16.00	0.6299	65.0	115.0	48.0	16.00

R463



Foret carbure monobloc FORCE M longueur 5xD avec arrosage centralisé, revêtement TiAlN

Foret haute performance capable de produire des trous précis de haute qualité à des vitesses et des avances élevées (tolérance de trou H9 dans les aciers inoxydables et les matériaux réfractaires). Une pointe à 140° avec 4 facettes et une conception de goujure CTW. L'arrosage centralisé améliore l'évacuation des copeaux. Le revêtement TiAlN augmente la dureté en surface et améliore la durée de vie de l'outil.

FORCE M

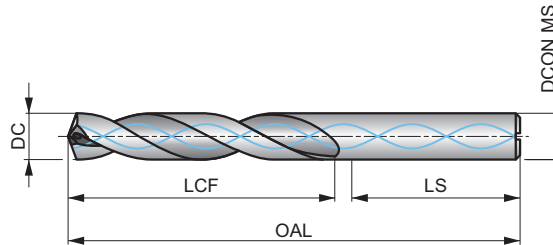

HM	DIN 6537L	5xD
140°	TiAlN	DIN 6535HA
CTW	R	
DC m7		

Adéquation du groupe de matériaux de la pièce, valeurs de départ pour la vitesse de coupe (m/min) et code Alpha d'avance. Les tableaux d'avances par tour se trouvent à partir de la page 274.

M1.1 ■ 111 G	M1.2 ■ 94 G	M2.1 ■ 99 G	M2.2 ■ 81 G	M2.3 ■ 67 E	M3.1 ■ 83 G	M3.2 ■ 71 G	M3.3 ■ 65 F	M4.1 ■ 57 F	M4.2 ■ 49 E	S1.1 ■ 52 V	S1.2 ■ 43 V	S1.3 ■ 38 U	S2.1 ■ 57 U
S2.2 ■ 53 U	S3.1 ■ 43 U	S3.2 ■ 38 U	S4.1 ■ 33 U	S4.2 ■ 30 U									

DCON MS tolérance h6.

Product	DC (inch)	DC (mm)	DC (inch)	LCF (mm)	OAL (mm)	LS (mm)	DCON MS (mm)
R4633.0	–	3.00	0.1181	28.0	66.0	36.0	6.00
R4633.1	–	3.10	0.1220	28.0	66.0	36.0	6.00
R4631/8	1/8	3.18	0.1250	28.0	66.0	36.0	6.00
R4633.2	–	3.20	0.1260	28.0	66.0	36.0	6.00
R4633.3	–	3.30	0.1299	28.0	66.0	36.0	6.00
R4633.4	–	3.40	0.1339	28.0	66.0	36.0	6.00
R463N29	N29	3.45	0.1360	28.0	66.0	36.0	6.00
R4633.5	–	3.50	0.1378	28.0	66.0	36.0	6.00
R4639/64	9/64	3.57	0.1406	28.0	66.0	36.0	6.00
R4633.6	–	3.60	0.1417	28.0	66.0	36.0	6.00
R4633.7	–	3.70	0.1457	28.0	66.0	36.0	6.00
R4633.8	–	3.80	0.1496	36.0	74.0	36.0	6.00
R4633.9	–	3.90	0.1535	36.0	74.0	36.0	6.00
R4635/32	5/32	3.97	0.1563	36.0	74.0	36.0	6.00
R4634.0	–	4.00	0.1575	36.0	74.0	36.0	6.00
R4634.05	–	4.05	0.1594	36.0	74.0	36.0	6.00
R4634.1	–	4.10	0.1614	36.0	74.0	36.0	6.00
R4634.2	–	4.20	0.1654	36.0	74.0	36.0	6.00
R4634.3	–	4.30	0.1693	36.0	74.0	36.0	6.00
R46311/64	11/64	4.37	0.1719	36.0	74.0	36.0	6.00
R4634.4	–	4.40	0.1732	36.0	74.0	36.0	6.00
R4634.5	–	4.50	0.1772	36.0	74.0	36.0	6.00
R4634.6	–	4.60	0.1811	36.0	74.0	36.0	6.00
R4634.7	–	4.70	0.1850	36.0	74.0	36.0	6.00
R4633/16	3/16	4.76	0.1875	44.0	82.0	36.0	6.00
R4634.8	–	4.80	0.1890	44.0	82.0	36.0	6.00
R4634.9	–	4.90	0.1929	44.0	82.0	36.0	6.00
R4635.0	–	5.00	0.1969	44.0	82.0	36.0	6.00
R4635.05	–	5.05	0.1988	44.0	82.0	36.0	6.00

Product	DC	DC	DC	LCF	OAL	LS	DCON MS
	(inch)	(mm)	(inch)	(mm)	(mm)	(mm)	(mm)
R4635.1	–	5.10	0.2008	44.0	82.0	36.0	6.00
R463N7	N7	5.11	0.2010	44.0	82.0	36.0	6.00
R46313/64	13/64	5.16	0.2031	44.0	82.0	36.0	6.00
R4635.2	–	5.20	0.2047	44.0	82.0	36.0	6.00
R463N5	N5	5.22	0.2055	44.0	82.0	36.0	6.00
R4635.3	–	5.30	0.2087	44.0	82.0	36.0	6.00
R4635.5	–	5.50	0.2165	44.0	82.0	36.0	6.00
R4637/32	7/32	5.56	0.2188	44.0	82.0	36.0	6.00
R4635.6	–	5.60	0.2205	44.0	82.0	36.0	6.00
R4635.7	–	5.70	0.2244	44.0	82.0	36.0	6.00
R4635.8	–	5.80	0.2283	44.0	82.0	36.0	6.00
R4635.9	–	5.90	0.2323	44.0	82.0	36.0	6.00
R46315/64	15/64	5.95	0.2344	44.0	82.0	36.0	6.00
R4636.0	–	6.00	0.2362	44.0	82.0	36.0	6.00
R4636.05	–	6.05	0.2382	53.0	91.0	36.0	8.00
R4636.1	–	6.10	0.2402	53.0	91.0	36.0	8.00
R4636.2	–	6.20	0.2441	53.0	91.0	36.0	8.00
R4636.3	–	6.30	0.2480	53.0	91.0	36.0	8.00
R4631/4	1/4	6.35	0.2500	53.0	91.0	36.0	8.00
R4636.4	–	6.40	0.2520	53.0	91.0	36.0	8.00
R4636.5	–	6.50	0.2559	53.0	91.0	36.0	8.00
R4636.6	–	6.60	0.2598	53.0	91.0	36.0	8.00
R4636.7	–	6.70	0.2638	53.0	91.0	36.0	8.00
R46317/64	17/64	6.75	0.2656	53.0	91.0	36.0	8.00
R4636.8	–	6.80	0.2677	53.0	91.0	36.0	8.00
R4636.9	–	6.90	0.2717	53.0	91.0	36.0	8.00
R4637.0	–	7.00	0.2756	53.0	91.0	36.0	8.00
R4637.1	–	7.10	0.2795	53.0	91.0	36.0	8.00
R4637.2	–	7.20	0.2835	53.0	91.0	36.0	8.00
R4637.3	–	7.30	0.2874	53.0	91.0	36.0	8.00
R4637.4	–	7.40	0.2913	53.0	91.0	36.0	8.00
R4637.5	–	7.50	0.2953	53.0	91.0	36.0	8.00
R4637.6	–	7.60	0.2992	53.0	91.0	36.0	8.00
R4637.7	–	7.70	0.3031	53.0	91.0	36.0	8.00
R4637.8	–	7.80	0.3071	53.0	91.0	36.0	8.00
R4637.9	–	7.90	0.3110	53.0	91.0	36.0	8.00
R4635/16	5/16	7.94	0.3125	53.0	91.0	36.0	8.00
R4638.0	–	8.00	0.3150	53.0	91.0	36.0	8.00
R4638.05	–	8.05	0.3169	61.0	103.0	40.0	10.00
R4638.1	–	8.10	0.3189	61.0	103.0	40.0	10.00
R4638.2	–	8.20	0.3228	61.0	103.0	40.0	10.00
R4638.3	–	8.30	0.3268	61.0	103.0	40.0	10.00
R46321/64	21/64	8.33	0.3281	61.0	103.0	40.0	10.00
R4638.4	–	8.40	0.3307	61.0	103.0	40.0	10.00
R4638.5	–	8.50	0.3346	61.0	103.0	40.0	10.00
R4638.6	–	8.60	0.3386	61.0	103.0	40.0	10.00
R4638.7	–	8.70	0.3425	61.0	103.0	40.0	10.00
R46311/32	11/32	8.73	0.3438	61.0	103.0	40.0	10.00
R4638.8	–	8.80	0.3465	61.0	103.0	40.0	10.00
R4638.9	–	8.90	0.3504	61.0	103.0	40.0	10.00
R4639.0	–	9.00	0.3543	61.0	103.0	40.0	10.00
R4639.1	–	9.10	0.3583	61.0	103.0	40.0	10.00
R46323/64	23/64	9.13	0.3594	61.0	103.0	40.0	10.00
R4639.2	–	9.20	0.3622	61.0	103.0	40.0	10.00
R4639.3	–	9.30	0.3661	61.0	103.0	40.0	10.00
R4639.4	–	9.40	0.3701	61.0	103.0	40.0	10.00
R4639.5	–	9.50	0.3740	61.0	103.0	40.0	10.00
R4633/8	3/8	9.53	0.3750	61.0	103.0	40.0	10.00
R4639.6	–	9.60	0.3780	61.0	103.0	40.0	10.00
R4639.7	–	9.70	0.3819	61.0	103.0	40.0	10.00
R4639.8	–	9.80	0.3858	61.0	103.0	40.0	10.00
R4639.9	–	9.90	0.3898	61.0	103.0	40.0	10.00

Product	DC	DC	DC	LCF	OAL	LS	DCON MS
	(inch)	(mm)	(inch)	(mm)	(mm)	(mm)	(mm)
R46310.0	–	10.00	0.3937	61.0	103.0	40.0	10.00
R46310.05	–	10.05	0.3957	70.0	118.0	45.0	12.00
R46310.1	–	10.10	0.3976	70.0	118.0	45.0	12.00
R46310.2	–	10.20	0.4016	70.0	118.0	45.0	12.00
R46310.3	–	10.30	0.4055	70.0	118.0	45.0	12.00
R46313/32	13/32	10.32	0.4063	70.0	118.0	45.0	12.00
R46310.4	–	10.40	0.4094	70.0	118.0	45.0	12.00
R46310.5	–	10.50	0.4134	70.0	118.0	45.0	12.00
R46327/64	27/64	10.72	0.4219	70.0	118.0	45.0	12.00
R46310.8	–	10.80	0.4252	70.0	118.0	45.0	12.00
R46311.0	–	11.00	0.4331	70.0	118.0	45.0	12.00
R4637/16	7/16	11.11	0.4375	70.0	118.0	45.0	12.00
R46311.2	–	11.20	0.4409	70.0	118.0	45.0	12.00
R46311.3	–	11.30	0.4449	70.0	118.0	45.0	12.00
R46311.4	–	11.40	0.4488	70.0	118.0	45.0	12.00
R46311.5	–	11.50	0.4528	70.0	118.0	45.0	12.00
R46329/64	29/64	11.51	0.4531	70.0	118.0	45.0	12.00
R46311.6	–	11.60	0.4567	70.0	118.0	45.0	12.00
R46311.8	–	11.80	0.4646	70.0	118.0	45.0	12.00
R46315/32	15/32	11.91	0.4688	70.0	118.0	45.0	12.00
R46312.0	–	12.00	0.4724	70.0	118.0	45.0	12.00
R46312.05	–	12.05	0.4744	76.0	124.0	45.0	14.00
R46312.2	–	12.20	0.4803	76.0	124.0	45.0	14.00
R46331/64	31/64	12.30	0.4844	76.0	124.0	45.0	14.00
R46312.5	–	12.50	0.4921	76.0	124.0	45.0	14.00
R46312.7	–	12.70	0.5000	76.0	124.0	45.0	14.00
R4631/2	1/2	12.70	0.5000	76.0	124.0	45.0	14.00
R46312.8	–	12.80	0.5039	76.0	124.0	45.0	14.00
R46313.0	–	13.00	0.5118	76.0	124.0	45.0	14.00
R46333/64	33/64	13.10	0.5156	76.0	124.0	45.0	14.00
R46313.5	–	13.50	0.5315	76.0	124.0	45.0	14.00
R46313.8	–	13.80	0.5433	76.0	124.0	45.0	14.00
R46314.0	–	14.00	0.5512	76.0	124.0	45.0	14.00
R46314.25	–	14.25	0.5610	82.0	133.0	48.0	16.00
R46314.5	–	14.50	0.5709	82.0	133.0	48.0	16.00
R46315.0	–	15.00	0.5906	82.0	133.0	48.0	16.00
R46315.3	–	15.30	0.6024	82.0	133.0	48.0	16.00
R46315.5	–	15.50	0.6102	82.0	133.0	48.0	16.00
R46315.8	–	15.80	0.6220	82.0	133.0	48.0	16.00
R46316.0	–	16.00	0.6299	82.0	133.0	48.0	16.00

R7131



Foret étagé en carbure monobloc avec arrosage centralisé, revêtement TiAlN

Foret polyvalent avec des diamètres pilotes et des longueurs spécifiques adaptés à la réalisation de filetages métriques. Le perçage et le chanfreinage en une seule opération réduit le temps de cycle et les stocks d'outils. Angle de pointe à 140° et chanfrein à 90°. Le revêtement TiAlN améliore les performances et prolonge la durée de vie de l'outil. Convient pour le perçage de nombreux matériaux.

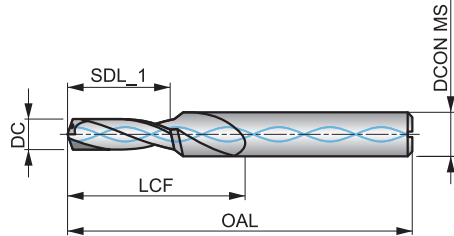

HM	DORMER	3xD
90°	TiAlN	DIN 6535HA
λ 20-35°	R	
DC m7		

Adéquation du groupe de matériaux de la pièce, valeurs de départ pour la vitesse de coupe (m/min) et code Alpha d'avance. Les tableaux d'avances par tour se trouvent à partir de la page 274.

P1.1 ■ 139 W	P1.2 ■ 156 W	P1.3 ■ 161 W	P2.1 ■ 119 W	P2.2 ■ 105 W	P2.3 ■ 93 V	P3.1 ■ 96 V	P3.2 ■ 77 V	P3.3 ■ 65 V	P4.1 ■ 57 V	P4.2 ■ 48 V	M1.1 ■ 62 V	M1.2 ■ 52 V	M2.1 ■ 55 V
M2.2 ■ 45 V	M3.1 ■ 47 V	M3.2 ■ 40 V	M3.3 ■ 36 U	M4.1 ■ 35 U	K1.1 ■ 90 W	K1.2 ■ 67 W	K1.3 ■ 50 W	K2.1 ■ 92 V	K2.2 ■ 75 V	K2.3 ■ 60 V	K3.1 ■ 82 V	K3.2 ■ 62 V	K3.3 ■ 50 V
K4.1 ■ 76 V	K4.2 ■ 57 V	K4.3 ■ 42 V	K4.4 ■ 36 V	K4.5 ■ 30 V	K5.1 ■ 86 V	K5.2 ■ 64 V	K5.3 ■ 50 V	N1.1 ■ 250 W	N1.2 ■ 188 W	N1.3 ■ 125 W	N2.1 ■ 308 V	N2.2 ■ 277 V	N2.3 ■ 200 V
N3.1 ■ 373 W	N3.2 ■ 220 W	N3.3 ■ 110 W											

DCON MS tolérance h6.

Product	DC (mm)	DC (inch)	SDL_1 (mm)	LCF (mm)	OAL (mm)	DCON MS (mm)	TDZ
R71313.3	3.30	0.1299	11.40	20.0	66.0	6.00	M4
R71314.2	4.20	0.1654	13.60	24.0	66.0	6.00	M5
R71315.0	5.00	0.1969	16.50	28.0	79.0	8.00	M6
R71316.8	6.80	0.2677	21.00	34.0	89.0	10.00	M8
R71318.5	8.50	0.3346	25.50	47.0	102.0	12.00	M10
R713110.2	10.20	0.4016	30.00	55.0	107.0	14.00	M12
R713110.4	10.40	0.4094	30.00	55.0	107.0	14.00	M12

Code de matériau du corps (BMC)	HSS	HSS	HSS	HSS	HSS	HM	HM						
Groupe standard de base (BSG)													
Rapport longueur utile diamètre (ULDR)	1.5xD	3xD	5xD	8xD	12xD								
Angle d'application													
Revêtement													
Queue													
Sens (direction de coupe)													
Propriété d'alimentation en liquide de coupe (CSP)													

Code de famille de produits	H851	H853	H855	H858	H8512	R950	R960	H860	H861				
Plage de diamètres de coupe PSF	31/64 - 30.00	12.00 - 42.50	12.00 - 42.50	14.00 - 42.50	14.00 - 25.00	15/32 - 42.00	15/32 - 30.50	N1 - N7	N1 - N5				
	218	219	221	223	224	225	227	229	229				

P	P1						■	■					
	P2						■	■					
	P3						■	■					
	P4						■	■					
M	M1							■					
	M2							■					
	M3							■					
	M4							■					
K	K1							■					
	K2						■	■					
	K3						■	■					
	K4						■	■					
	K5						■	■					
N	N1												
	N2												
	N3												
	N4												
	N5												
S	S1							■					
	S2							■					
	S3							■					
	S4							■					
H	H1												
	H2												
	H3												
	H4												

H851



Corps HYDRA 1,5XD, avec arrosage centralisé, nickelé brillant

Corps HYDRA utilisable avec les têtes R950 et R960. Une gamme de diamètres de tête peut être utilisée avec le même corps. Les trous d'arrosage centralisé alignés avec les têtes offrent un refroidissement efficace. La queue épaulée empêche le foret de se déplacer dans l'attachement. La surface nickelée protège de la corrosion et améliore l'évacuation des copeaux.

HYDRA

HSS	DORMER	1.5xD
Bright Ni	ISO 9766	R

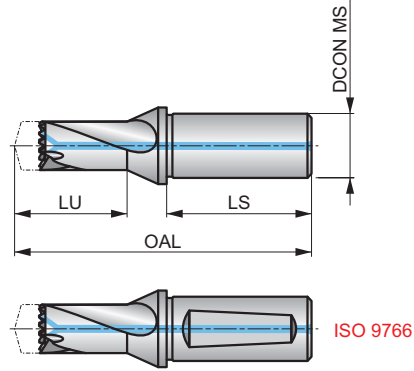

Quatre (4) vis et un (1) tournevis sont livrés avec le corps du foret, DCON MS tolérance h6.

Product	DCON MS	DCON MS	LU	OAL	LS	ADINTMS
	(inch)	(mm)	(mm)	(mm)	(mm)	
H85131/64	5/8	15.88	25.50	88.5	47.6	Cylindrical
H85117/32	5/8	15.88	30.90	93.9	47.6	Cylindrical
H85112.0	–	16.00	25.50	88.5	48.0	ISO 9766
H85112.5	–	16.00	25.80	88.8	48.0	ISO 9766
H85113.0	–	16.00	27.00	90.0	48.0	ISO 9766
H85114.0	–	16.00	30.90	93.9	48.0	ISO 9766
H85139/64	3/4	19.05	32.30	97.3	50.8	Cylindrical
H85141/64	3/4	19.05	34.90	99.9	50.8	Cylindrical
H85111/16	3/4	19.05	36.40	101.4	50.8	Cylindrical
H85123/32	3/4	19.05	39.00	104.0	50.8	Cylindrical
H85115.0	–	20.00	32.30	97.3	50.0	ISO 9766
H85116.0	–	20.00	34.90	99.9	50.0	ISO 9766
H85117.0	–	20.00	36.40	101.4	50.0	ISO 9766
H85118.0	–	20.00	39.00	104.0	50.0	ISO 9766
H85119.0	–	25.00	40.40	111.4	56.0	ISO 9766
H85120.0	–	25.00	43.00	114.0	56.0	ISO 9766
H85121.0	–	25.00	44.50	115.5	56.0	ISO 9766
H85122.0	–	25.00	46.10	117.1	56.0	ISO 9766
H85123.0	–	25.00	47.00	118.0	56.0	ISO 9766
H85149/64	1"	25.40	40.40	111.4	57.1	Cylindrical
H85151/64	1"	25.40	43.00	114.0	57.1	Cylindrical
H85127/32	1"	25.40	44.50	115.5	57.1	Cylindrical
H85157/64	1"	25.40	46.10	117.1	57.1	Cylindrical
H85159/64	1"	25.40	47.00	118.0	57.1	Cylindrical
H85131/32	1"	25.40	49.30	124.3	57.1	Cylindrical
H8511.1/64	1.1/4	31.75	49.70	124.7	60.3	Cylindrical
H8511.3/64	1.1/4	31.75	52.30	127.3	60.3	Cylindrical
H8511.3/32	1.1/4	31.75	52.80	127.8	60.3	Cylindrical
H8511.3/16	1.1/4	31.75	58.40	133.4	60.3	Cylindrical
H85124.0	–	32.00	49.30	124.3	60.0	ISO 9766
H85125.0	–	32.00	49.70	124.7	60.0	ISO 9766
H85126.0	–	32.00	52.30	127.3	60.0	ISO 9766
H85127.0	–	32.00	52.80	127.8	60.0	ISO 9766
H85128.0	–	32.00	54.40	129.4	60.0	ISO 9766
H85129.0	–	32.00	55.80	130.8	60.0	ISO 9766
H85130.0	–	32.00	58.40	133.4	60.0	ISO 9766

H853



Corps HYDRA 3XD, avec arrosage centralisé, nickelage brillant

Corps HYDRA utilisable avec les têtes R950 et R960. Une gamme de diamètres de tête peut être utilisée avec le même corps. Les trous d'arrosage centralisé alignés avec les têtes offrent un refroidissement efficace. La surface nickelée brillante protège de la corrosion et améliore l'évacuation des copeaux.

HYDRA

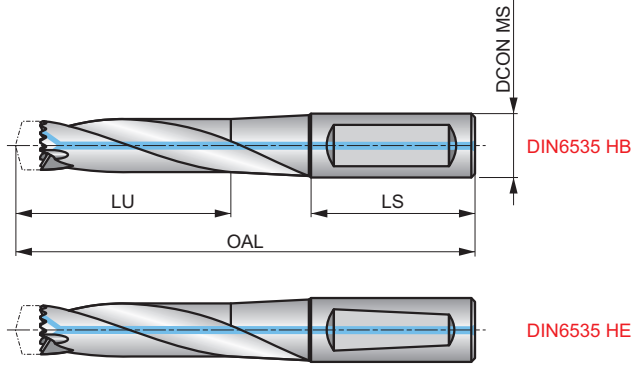

HSS	DORMER	3xD
Bright Ni	DIN 6535HB DIN 6535HE	R

Quatre (4) vis et un (1) tournevis sont livrés avec le corps du foret, DCON MS tolérance h6.

Product	DCON MS	DCON MS	LU	OAL	LS	ADINTMS
	(inch)	(mm)	(mm)	(mm)	(mm)	
H85312.0	–	16.00	44.00	105.0	48.0	DIN6535HE
H85331/64	5/8	15.88	44.00	105.0	48.0	DIN6535HB
H85312.5	–	16.00	44.00	105.0	48.0	DIN6535HE
H8531/2	5/8	15.88	44.00	105.0	48.0	DIN6535HB
H85313.0	–	16.00	47.00	110.0	48.0	DIN6535HE
H85317/32	5/8	15.88	47.00	110.0	48.0	DIN6535HB
H85314.0	–	16.00	52.50	116.5	48.0	DIN6535HE
H8539/16	3/4	19.05	52.50	116.5	48.0	DIN6535HB
H85315.0	–	20.00	55.50	126.5	50.0	DIN6535HE
H85339/64	3/4	19.05	55.50	126.5	50.0	DIN6535HB
H85316.0	–	20.00	59.50	131.5	50.0	DIN6535HE
H85341/64	3/4	19.05	59.50	131.5	50.0	DIN6535HB
H85317.0	–	20.00	62.50	136.5	50.0	DIN6535HE
H85311/16	3/4	19.05	62.50	136.5	50.0	DIN6535HB
H85318.0	–	20.00	66.50	141.5	50.0	DIN6535HE
H85323/32	3/4	19.05	66.50	141.5	50.0	DIN6535HB
H85319.0	–	25.00	69.50	156.5	56.0	DIN6535HE
H85349/64	1"	25.40	69.50	156.5	56.0	DIN6535HB
H85320.0	–	25.00	73.50	156.5	56.0	DIN6535HE
H85351/64	1"	25.40	73.50	156.5	56.0	DIN6535HB
H85321.0	–	25.00	76.50	156.5	56.0	DIN6535HE
H85327/32	1"	25.40	76.50	156.5	56.0	DIN6535HB
H85322.0	–	25.00	80.10	161.5	56.0	DIN6535HE
H85357/64	1"	25.40	80.10	161.5	56.0	DIN6535HB
H85323.0	–	25.00	82.50	160.5	56.0	DIN6535HE
H85359/64	1"	25.40	82.50	160.5	56.0	DIN6535HB
H85324.0	–	32.00	86.20	170.2	60.0	DIN6535HE
H85331/32	1"	25.40	86.20	170.2	60.0	DIN6535HB
H85325.0	–	32.00	88.00	170.0	60.0	DIN6535HE
H8531.1/64	1.1/4	31.75	88.00	170.0	60.0	DIN6535HB
H85326.0	–	32.00	92.00	175.0	60.0	DIN6535HE
H8531.3/64	1.1/4	31.75	92.00	175.0	60.0	DIN6535HB
H85327.0	–	32.00	94.00	175.0	60.0	DIN6535HE
H8531.3/32	1.1/4	31.75	94.00	175.0	60.0	DIN6535HB

Product	DCON MS	DCON MS	LU	OAL	LS	ADINTMS
	(inch)	(mm)	(mm)	(mm)	(mm)	
H85328.0	–	32.00	97.00	180.0	60.0	DIN6535HE
H8531.1/8	1.1/4	31.75	97.00	180.0	60.0	DIN6535HB
H85329.0	–	32.00	100.00	185.0	60.0	DIN6535HE
H8531.11/64	1.1/4	31.75	100.00	185.0	60.0	DIN6535HB
H85330.0	–	32.00	104.00	185.0	60.0	DIN6535HE
H8531.3/16	1.1/4	31.75	104.00	185.0	60.0	DIN6535HB
H85332.0	–	32.00	111.50	196.5	60.0	DIN6535HE
H85333.5	–	32.00	116.50	201.5	60.0	DIN6535HE
H85335.0	–	40.00	121.50	216.5	70.0	DIN6535HB
H85336.5	–	40.00	125.50	221.5	70.0	DIN6535HB
H85338.0	–	40.00	131.50	226.5	70.0	DIN6535HB
H85339.5	–	40.00	136.50	231.5	70.0	DIN6535HB
H85341.0	–	40.00	146.50	246.5	70.0	DIN6535HB
H85342.5	–	40.00	151.60	251.6	70.0	DIN6535HB

H855



Corps HYDRA 5XD, avec arrosage centralisé, nickelage brillant

Corps HYDRA utilisable avec les têtes R950 et R960. Une gamme de diamètres de tête peut être utilisée avec le même corps. Les trous d'arrosage centralisé alignés avec les têtes offrent un refroidissement efficace. La surface nickelée brillante protège de la corrosion et améliore l'évacuation des copeaux.

HYDRA

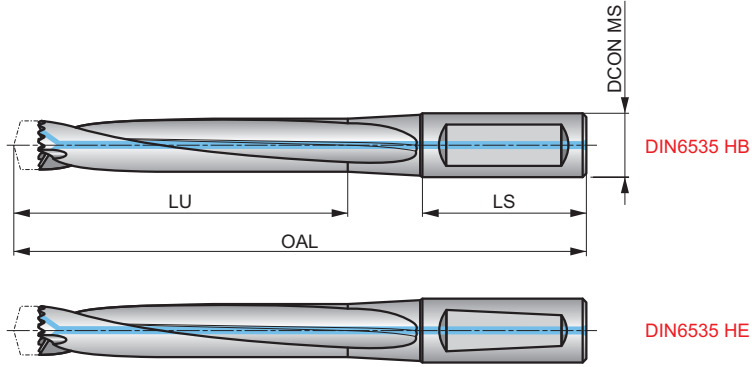

HSS	DORMER	5xD
Bright Ni	DIN 6535HB DIN 6535HE	R

Quatre (4) vis et un (1) tournevis sont livrés avec le corps du foret, DCON MS tolérance h6.

Product	DCON MS	DCON MS	LU	OAL	LS	ADINTMS
	(inch)	(mm)	(mm)	(mm)	(mm)	
H85512.0	–	16.00	69.00	130.0	48.0	DIN6535HE
H85531/64	5/8	15.88	69.00	130.0	48.0	DIN6535HB
H85512.5	–	16.00	69.00	130.0	48.0	DIN6535HE
H8551/2	5/8	15.88	69.00	130.0	48.0	DIN6535HB
H85513.0	–	16.00	74.00	140.0	48.0	DIN6535HE
H85517/32	5/8	15.88	74.00	140.0	48.0	DIN6535HB
H85514.0	–	16.00	81.50	146.5	48.0	DIN6535HE
H8559/16	3/4	19.05	81.50	146.5	48.0	DIN6535HB
H85515.0	–	20.00	86.50	156.5	50.0	DIN6535HE
H85539/64	3/4	19.05	86.50	156.5	50.0	DIN6535HB
H85516.0	–	20.00	92.50	166.5	50.0	DIN6535HE
H85541/64	3/4	19.05	92.50	166.5	50.0	DIN6535HB
H85517.0	–	20.00	97.50	171.5	50.0	DIN6535HE
H85511/16	3/4	19.05	97.50	171.5	50.0	DIN6535HB
H85518.0	–	20.00	103.50	176.5	50.0	DIN6535HE
H85523/32	3/4	19.05	103.50	176.5	50.0	DIN6535HB
H85519.0	–	25.00	108.50	191.5	56.0	DIN6535HE
H85549/64	1"	25.40	108.50	191.5	56.0	DIN6535HB
H85520.0	–	25.00	114.50	196.5	56.0	DIN6535HE
H85551/64	1"	25.40	114.50	196.5	56.0	DIN6535HB
H85521.0	–	25.00	119.50	196.5	56.0	DIN6535HE
H85527/32	1"	25.40	119.50	196.5	56.0	DIN6535HB
H85522.0	–	25.00	125.10	201.1	56.0	DIN6535HE
H85557/64	1"	25.40	125.10	201.1	56.0	DIN6535HB
H85523.0	–	25.00	129.50	210.5	56.0	DIN6535HE
H85559/64	1"	25.40	129.50	210.5	56.0	DIN6535HB
H85524.0	–	32.00	135.20	220.2	60.0	DIN6535HE
H85531/32	1"	25.40	135.20	220.2	60.0	DIN6535HB
H85525.0	–	32.00	140.00	225.0	60.0	DIN6535HE
H8551.1/64	1.1/4	31.75	140.00	225.0	60.0	DIN6535HB
H85526.0	–	32.00	146.00	230.0	60.0	DIN6535HE
H8551.3/64	1.1/4	31.75	146.00	230.0	60.0	DIN6535HB
H85527.0	–	32.00	151.00	235.0	60.0	DIN6535HE
H8551.3/32	1.1/4	31.75	151.00	235.0	60.0	DIN6535HB

Product	DCON MS	DCON MS	LU	OAL	LS	ADINTMS
	(inch)	(mm)	(mm)	(mm)	(mm)	
H85528.0	–	32.00	157.00	240.0	60.0	DIN6535HE
H8551.1/8	1.1/4	31.75	157.00	240.0	60.0	DIN6535HB
H85529.0	–	32.00	162.00	245.0	60.0	DIN6535HE
H8551.11/64	1.1/4	31.75	162.00	245.0	60.0	DIN6535HB
H85530.0	–	32.00	167.00	255.0	60.0	DIN6535HE
H8551.3/16	1.1/4	31.75	167.00	255.0	60.0	DIN6535HB
H85532.0	–	32.00	176.50	261.5	60.0	DIN6535HE
H85533.5	–	32.00	186.50	271.5	60.0	DIN6535HE
H85535.0	–	40.00	196.50	291.5	70.0	DIN6535HB
H85536.5	–	40.00	201.50	296.5	70.0	DIN6535HB
H85538.0	–	40.00	211.50	306.5	70.0	DIN6535HB
H85539.5	–	40.00	221.50	316.5	70.0	DIN6535HB
H85541.0	–	40.00	226.50	325.6	70.0	DIN6535HB
H85542.5	–	40.00	236.50	336.5	70.0	DIN6535HB



H858



Corps HYDRA 8XD, avec arrosage centralisé, nickelage brillant

Corps HYDRA utilisable avec les têtes R950 et R960. Une gamme de diamètres de tête peut être utilisée avec le même corps. Les trous d'arrosage centralisé alignés avec les têtes offrent un refroidissement efficace. La surface nickelée brillante protège de la corrosion et améliore l'évacuation des copeaux.

HYDRA

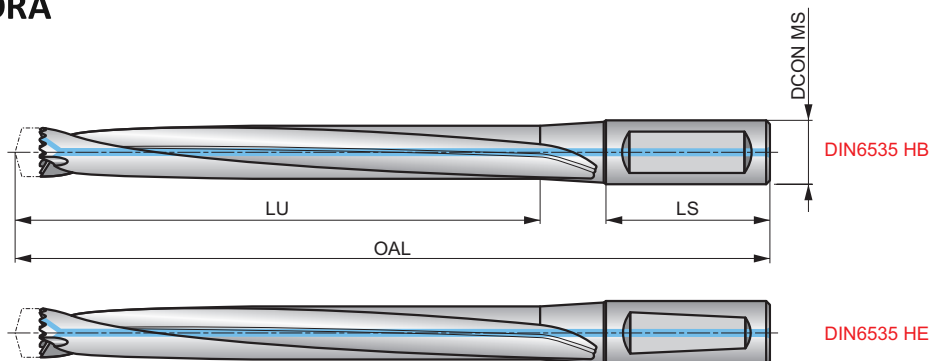

HSS	DORMER	8xD
Bright Ni	DIN 6535HB DIN 6535HE	R

Quatre (4) vis et un (1) tournevis sont livrés avec le corps du foret, DCON MS tolérance h6.

Product	DCON MS (mm)	LU (mm)	OAL (mm)	LS (mm)	ADINTMS
H85814.0	16.00	124.50	191.5	48.0	DIN6535HE
H85815.0	20.00	133.50	201.5	50.0	DIN6535HE
H85816.0	20.00	141.50	211.5	50.0	DIN6535HE
H85817.0	20.00	150.50	221.5	50.0	DIN6535HE
H85818.0	20.00	158.50	226.5	50.0	DIN6535HE
H85819.0	25.00	167.50	251.5	56.0	DIN6535HE
H85820.0	25.00	175.50	264.5	56.0	DIN6535HE
H85821.0	25.00	184.50	266.5	56.0	DIN6535HE
H85822.0	25.00	192.10	271.1	56.0	DIN6535HE
H85823.0	25.00	200.50	280.5	56.0	DIN6535HE
H85824.0	32.00	208.20	295.2	60.0	DIN6535HE
H85825.0	32.00	217.00	300.0	60.0	DIN6535HE
H85826.0	32.00	225.00	310.0	60.0	DIN6535HE
H85827.0	32.00	234.00	320.0	60.0	DIN6535HE
H85828.0	32.00	242.00	325.0	60.0	DIN6535HE
H85829.0	32.00	251.00	335.0	60.0	DIN6535HE
H85830.0	32.00	259.00	345.0	60.0	DIN6535HE
H85832.0	32.00	271.50	356.5	60.0	DIN6535HE
H85833.5	32.00	286.50	371.5	60.0	DIN6535HE
H85835.0	40.00	301.50	396.5	70.0	DIN6535HB
H85836.5	40.00	311.50	406.5	70.0	DIN6535HB
H85838.0	40.00	326.50	421.5	70.0	DIN6535HB
H85839.5	40.00	336.50	431.5	70.0	DIN6535HB
H85841.0	40.00	351.50	451.5	70.0	DIN6535HB
H85842.5	40.00	361.50	461.5	70.0	DIN6535HB

H8512



Corps HYDRA 12XD, avec arrosage centralisé, nickelage brillant

Corps HYDRA utilisable avec les têtes R950 et R960. Une gamme de diamètres de tête peut être utilisée avec le même corps. Les trous d'arrosage centralisé alignés avec les têtes offrent un refroidissement efficace. La queue épaulée empêche le foret de se déplacer dans l'attache. La surface nickelée protège de la corrosion et améliore l'évacuation des copeaux.

HYDRA

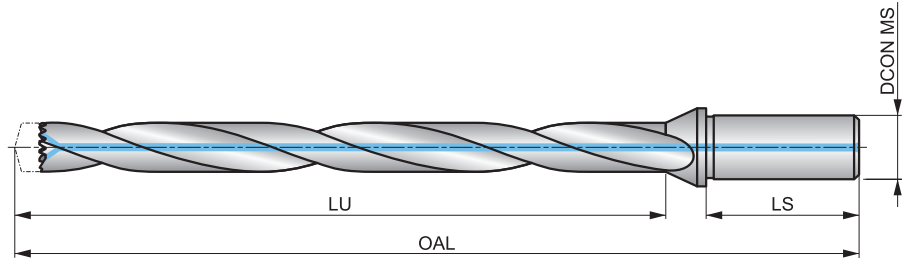

HSS	DORMER	12xD
Bright Ni		R

Quatre (4) vis et un (1) tournevis sont livrés avec le corps du foret, DCON MS tolérance h6.

Product	DCON MS (mm)	LU (mm)	OAL (mm)	LS (mm)
H851214.0	16.00	168.00	236.0	48.0
H851215.0	20.00	180.00	250.3	50.0
H851216.0	20.00	192.00	262.6	50.0
H851217.0	20.00	204.00	275.0	50.0
H851218.0	20.00	216.00	287.2	50.0
H851219.0	25.00	228.00	305.6	56.0
H851220.0	25.00	240.00	317.8	56.0
H851221.0	25.00	252.00	330.1	56.0
H851222.0	25.00	264.00	343.0	56.0
H851223.0	25.00	276.00	354.8	56.0
H851224.0	32.00	288.00	371.7	60.0
H851225.0	32.00	300.00	383.8	60.0

R950

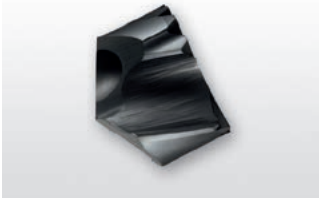

Tête de perçage HYDRA pour les aciers, revêtement Ti-phon

Tête HYDRA interchangeable en carbure, très rentable et conçue avec précision pour des performances élevées dans les aciers et les matériaux plus durs. Un affûtage en croix à 140° facilite l'autocentrage et réduit les forces de coupe. Le revêtement Ti-phon empêche le phénomène d'arête rapportée et améliore considérablement le glissement des copeaux, avec une résistance à l'usure et une solidité des arêtes supérieures.

HYDRA

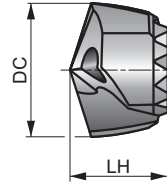

H851	Appliquer les valeurs de vitesse et d'avance initiales avec un facteur de correction de 1.10
H853	Appliquer les valeurs de vitesse et d'avance initiales avec un facteur de correction de 1.00
H855	Appliquer les valeurs de vitesse et d'avance initiales avec un facteur de correction de 0.80
H858	Appliquer les valeurs de vitesse et d'avance initiales avec un facteur de correction de 0.60
H8512	Appliquer les valeurs de vitesse et d'avance initiales avec un facteur de correction de 0.50

Adéquation du groupe de matériaux de la pièce, valeurs de départ pour la vitesse de coupe (m/min) et code Alpha d'avance. Les tableaux d'avances par tour se trouvent à partir de la page 274.

P1.1 133 W	P1.2 148 W	P1.3 154 W	P2.1 114 W	P2.2 100 W	P2.3 88 W	P3.1 125 W	P3.2 101 W	P3.3 85 W	P4.1 75 W	P4.2 63 W	P4.3 52 T	M2.3 41 T	M4.2 35 T
K2.1 108 V	K2.2 88 V	K2.3 70 V	K3.1 96 V	K3.2 73 V	K3.3 59 V	K4.1 89 V	K4.2 67 V	K4.3 49 V	K4.4 42 V	K4.5 35 V	K5.1 100 V	K5.2 76 V	K5.3 58 V

Product	DC	DC	DC	LH
	(inch)	(mm)	(inch)	(mm)
R95015/32	15/32	11.91	0.4688	9.1
R95012.0	–	12.00	0.4724	9.1
R95012.1	–	12.10	0.4764	9.1
R95012.2	–	12.20	0.4803	9.1
R95031/64	31/64	12.30	0.4844	9.1
R95012.5	–	12.50	0.4921	9.4
R95012.6	–	12.60	0.4961	9.4
R9501/2	1/2	12.70	0.5000	9.4
R95012.8	–	12.80	0.5039	9.4
R95012.9	–	12.90	0.5079	9.4
R95013.0	–	13.00	0.5118	9.7
R95033/64	33/64	13.10	0.5156	9.7
R95013.2	–	13.20	0.5197	9.7
R95017/32	17/32	13.49	0.5313	9.7
R95013.5	–	13.50	0.5315	10.3
R95013.6	–	13.60	0.5354	10.3
R95013.7	–	13.70	0.5394	10.3
R95013.8	–	13.80	0.5433	10.3
R95035/64	35/64	13.89	0.5469	10.3
R95014.0	–	14.00	0.5512	10.3
R95014.1	–	14.10	0.5551	10.3
R95014.2	–	14.20	0.5591	10.3
R9509/16	9/16	14.29	0.5625	10.3
R95014.5	–	14.50	0.5709	10.3
R95014.6	–	14.60	0.5748	11.0
R95037/64	37/64	14.68	0.5781	11.0
R95014.7	–	14.70	0.5787	11.0
R95014.8	–	14.80	0.5827	11.0
R95015.0	–	15.00	0.5906	11.0
R95019/32	19/32	15.08	0.5938	11.0

Product	DC	DC	DC	LH
	(inch)	(mm)	(inch)	(mm)
R95015.1	–	15.10	0.5945	11.0
R95015.2	–	15.20	0.5984	11.0
R95015.24	–	15.24	0.6000	11.0
R95039/64	39/64	15.48	0.6094	11.0
R95015.5	–	15.50	0.6102	11.0
R95015.6	–	15.60	0.6142	11.6
R95015.7	–	15.70	0.6181	11.6
R9505/8	5/8	15.88	0.6250	11.6
R95016.0	–	16.00	0.6299	11.6
R95016.08	–	16.08	0.6331	11.6
R95016.1	–	16.10	0.6339	11.6
R95016.2	–	16.20	0.6378	11.6
R95041/64	41/64	16.27	0.6406	11.6
R95016.3	–	16.30	0.6417	11.6
R95016.5	–	16.50	0.6496	11.6
R95016.6	–	16.60	0.6535	12.2
R95021/32	21/32	16.67	0.6563	12.2
R95016.7	–	16.70	0.6575	12.2
R95017.0	–	17.00	0.6693	12.2
R95043/64	43/64	17.07	0.6719	12.2
R95017.1	–	17.10	0.6732	12.2
R95017.2	–	17.20	0.6772	12.2
R95011/16	11/16	17.46	0.6875	12.2
R95017.5	–	17.50	0.6890	12.2
R95017.6	–	17.60	0.6929	12.9
R95017.7	–	17.70	0.6969	12.9
R95045/64	45/64	17.86	0.7031	12.9
R95018.0	–	18.00	0.7087	12.9
R95018.1	–	18.10	0.7126	12.9
R95018.2	–	18.20	0.7165	12.9

Product	DC	DC	DC	LH
	(inch)	(mm)	(inch)	(mm)
R95023/32	23/32	18.26	0.7188	12.9
R95018.5	–	18.50	0.7283	12.9
R95018.6	–	18.60	0.7323	13.5
R95047/64	47/64	18.65	0.7344	13.5
R95018.7	–	18.70	0.7362	13.5
R95018.9	–	18.90	0.7441	13.5
R95019.0	–	19.00	0.7480	13.5
R9503/4	3/4	19.05	0.7500	13.5
R95019.1	–	19.10	0.7520	13.5
R95019.2	–	19.20	0.7559	13.5
R95019.25	–	19.25	0.7579	13.5
R95019.3	–	19.30	0.7598	13.5
R95019.35	–	19.35	0.7618	13.5
R95049/64	49/64	19.45	0.7656	13.5
R95019.5	–	19.50	0.7677	13.5
R95019.6	–	19.60	0.7717	14.1
R95019.7	–	19.70	0.7756	14.1
R95025/32	25/32	19.84	0.7813	14.1
R95020.0	–	20.00	0.7874	14.1
R95051/64	51/64	20.24	0.7969	14.1
R95020.5	–	20.50	0.8071	14.1
R95013/16	13/16	20.64	0.8125	14.8
R95021.0	–	21.00	0.8268	14.8
R95053/64	53/64	21.03	0.8281	14.8
R95027/32	27/32	21.43	0.8438	14.8
R95021.5	–	21.50	0.8465	14.8
R95055/64	55/64	21.83	0.8594	15.0
R95022.0	–	22.00	0.8661	15.0
R9507/8	7/8	22.22	0.8750	15.0
R95022.5	–	22.50	0.8858	15.0
R95057/64	57/64	22.62	0.8906	15.0
R95022.7	–	22.70	0.8937	15.0
R95023.0	–	23.00	0.9055	15.1
R95029/32	29/32	23.02	0.9063	15.1
R95059/64	59/64	23.42	0.9219	15.1
R95023.5	–	23.50	0.9252	15.1
R95015/16	15/16	23.81	0.9375	15.4
R95024.0	–	24.00	0.9449	15.4
R95061/64	61/64	24.21	0.9531	15.4
R95024.5	–	24.50	0.9646	15.4
R95031/32	31/32	24.61	0.9688	15.4
R95025.0	–	25.00	0.9844	15.8
R95063/64	63/64	25.00	0.9844	15.8
R9501	1"	25.40	1.0000	15.8
R95025.5	–	25.50	1.0039	15.8
R95025.6	–	25.60	1.0079	15.8
R95025.65	–	25.65	1.0098	15.8
R9501.1/64	1.1/64	25.80	1.0156	15.8
R95026.0	–	26.00	1.0236	16.4
R9501.1/32	1.1/32	26.19	1.0313	16.4

Product	DC	DC	DC	LH
	(inch)	(mm)	(inch)	(mm)
R95026.5	–	26.50	1.0433	16.4
R9501.3/64	1.3/64	26.59	1.0469	16.4
R9501.1/16	1.1/16	26.99	1.0625	17.1
R95027.0	–	27.00	1.0630	17.1
R9501.5/64	1.5/64	27.38	1.0781	17.1
R95027.5	–	27.50	1.0827	17.1
R9501.3/32	1.3/32	27.78	1.0938	17.1
R95028.0	–	28.00	1.1024	17.7
R9501.7/64	1.7/64	28.18	1.1094	17.7
R95028.5	–	28.50	1.1220	17.7
R9501.1/8	1.1/8	28.58	1.1250	17.7
R9501.9/64	1.9/64	28.97	1.1406	18.3
R95029.0	–	29.00	1.1417	18.3
R9501.5/32	1.5/32	29.37	1.1563	18.3
R95029.5	–	29.50	1.1614	18.3
R9501.11/64	1.11/64	29.77	1.1719	18.3
R95030.0	–	30.00	1.1811	19.0
R9501.3/16	1.3/16	30.16	1.1875	19.0
R95030.5	–	30.50	1.2008	19.0
R9501.7/32	1.7/32	30.96	1.2188	21.0
R95031.0	–	31.00	1.2205	21.0
R9501.1/4	1.1/4	31.75	1.2500	21.0
R95032.0	–	32.00	1.2598	21.0
R95032.5	–	32.50	1.2795	21.0
R9501.19/64	1.19/64	32.94	1.2969	21.0
R95033.0	–	33.00	1.2992	21.0
R95033.5	–	33.50	1.3189	21.0
R95034.0	–	34.00	1.3386	23.0
R9501.11/32	1.11/32	34.13	1.3438	23.0
R95034.5	–	34.50	1.3583	23.0
R9501.3/8	1.3/8	34.93	1.3750	23.0
R95035.0	–	35.00	1.3780	23.0
R95036.0	–	36.00	1.4173	23.0
R9501.27/64	1.27/64	36.12	1.4219	23.0
R95036.5	–	36.50	1.4370	23.0
R95037.0	–	37.00	1.4567	25.0
R9501.15/32	1.15/32	37.31	1.4688	25.0
R95037.5	–	37.50	1.4764	25.0
R95038.0	–	38.00	1.4961	25.0
R9501.1/2	1.1/2	38.10	1.5000	25.0
R95038.5	–	38.50	1.5157	25.0
R9501.17/32	1.17/32	38.89	1.5313	25.0
R95039.0	–	39.00	1.5354	25.0
R95039.5	–	39.50	1.5551	25.0
R9501.9/16	1.9/16	39.69	1.5625	27.0
R95040.0	–	40.00	1.5748	27.0
R95041.0	–	41.00	1.6142	27.0
R9501.5/8	1.5/8	41.28	1.6250	27.0
R95042.0	–	42.00	1.6535	27.0

R960

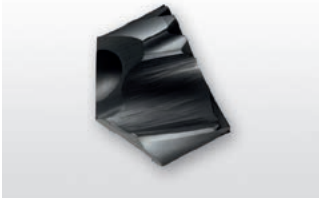

Tête de perçage HYDRA pour aciers inoxydables, revêtement Ti-phon

Tête HYDRA interchangeable en carbure, très rentable et conçue avec précision pour des performances élevées dans les aciers inoxydables. Un affûtage en croix à 140° facilite l'autocentrage et réduit les forces de coupe. Le revêtement Ti-phon empêche le phénomène d'arête rapportée et améliore considérablement le glissement des copeaux, avec une résistance à l'usure et une solidité des arêtes supérieures.

HYDRA

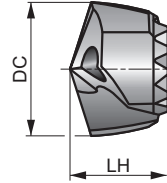

HM	DORMER	140°
Ti-phon	R	Blue chip coating icon
DC h7		

H851	Appliquer les valeurs de vitesse et d'avance initiales avec un facteur de correction de 1.10
H853	Appliquer les valeurs de vitesse et d'avance initiales avec un facteur de correction de 1.00
H855	Appliquer les valeurs de vitesse et d'avance initiales avec un facteur de correction de 0.80
H858	Appliquer les valeurs de vitesse et d'avance initiales avec un facteur de correction de 0.60
H8512	Appliquer les valeurs de vitesse et d'avance initiales avec un facteur de correction de 0.50

Adéquation du groupe de matériaux de la pièce, valeurs de départ pour la vitesse de coupe (m/min) et code Alpha d'avance. Les tableaux d'avances par tour se trouvent à partir de la page 274.

P1.1	P1.2	P1.3	P2.1	M1.1	M1.2	M2.1	M2.2	M2.3	M3.1	M3.2	M3.3	M4.1	M4.2
■ 133 W	■ 148 W	■ 154 W	■ 114 W	■ 82 V	■ 70 V	■ 73 V	■ 60 V	▣ 50 T	■ 58 T	■ 50 T	■ 45 T	■ 40 T	▣ 34 T
K1.1	K1.2	K1.3	K2.1	K2.2	K2.3	K3.1	K3.2	K3.3	K4.1	K4.2	K4.3	K4.4	K4.5
■ 120 V	■ 89 V	■ 67 V	▣ 108 V	▣ 88 V	▣ 70 V	▣ 96 V	▣ 73 V	▣ 59 V	▣ 89 V	▣ 67 V	▣ 49 V	▣ 42 V	▣ 35 V
K5.1	K5.2	K5.3	S1.1	S1.2	S1.3	S2.1	S2.2	S3.1	S3.2	S4.1	S4.2		
▣ 100 V	▣ 76 V	▣ 58 V	▣ 45 T	▣ 35 T	▣ 30 S	▣ 40 S	▣ 35 S	▣ 30 S	▣ 25 S	▣ 23 S	▣ 20 S		

Product	DC	DC	DC	LH
	(inch)	(mm)	(inch)	(mm)
R96015/32	15/32	11.91	0.4688	9.1
R96012.0	–	12.00	0.4724	9.1
R96012.1	–	12.10	0.4764	9.1
R96012.2	–	12.20	0.4803	9.1
R96031/64	31/64	12.30	0.4844	9.1
R96012.5	–	12.50	0.4921	9.4
R96012.6	–	12.60	0.4961	9.4
R9601/2	1/2	12.70	0.5000	9.4
R96012.8	–	12.80	0.5039	9.4
R96012.9	–	12.90	0.5079	9.4
R96013.0	–	13.00	0.5118	9.7
R96033/64	33/64	13.10	0.5156	9.7
R96013.2	–	13.20	0.5197	9.7
R96017/32	17/32	13.49	0.5313	9.7
R96013.5	–	13.50	0.5315	10.3
R96013.6	–	13.60	0.5354	10.3
R96013.7	–	13.70	0.5394	10.3
R96013.8	–	13.80	0.5433	10.3
R96035/64	35/64	13.89	0.5469	10.3
R96014.0	–	14.00	0.5512	10.3
R96014.1	–	14.10	0.5551	10.3
R96014.2	–	14.20	0.5591	10.3
R9609/16	9/16	14.29	0.5625	10.3
R96014.5	–	14.50	0.5709	10.3
R96014.6	–	14.60	0.5748	11.0
R96037/64	37/64	14.68	0.5781	11.0
R96014.7	–	14.70	0.5787	11.0
R96014.8	–	14.80	0.5827	11.0

Product	DC	DC	DC	LH
	(inch)	(mm)	(inch)	(mm)
R96015.0	–	15.00	0.5906	11.0
R96019/32	19/32	15.08	0.5938	11.0
R96015.1	–	15.10	0.5945	11.0
R96015.2	–	15.20	0.5984	11.0
R96015.24	–	15.24	0.6000	11.0
R96039/64	39/64	15.48	0.6094	11.0
R96015.5	–	15.50	0.6102	11.0
R96015.6	–	15.60	0.6142	11.6
R96015.7	–	15.70	0.6181	11.6
R9605/8	5/8	15.88	0.6250	11.6
R96016.0	–	16.00	0.6299	11.6
R96016.08	–	16.08	0.6331	11.6
R96016.1	–	16.10	0.6339	11.6
R96016.2	–	16.20	0.6378	11.6
R96041/64	41/64	16.27	0.6406	11.6
R96016.3	–	16.30	0.6417	11.6
R96016.5	–	16.50	0.6496	11.6
R96016.6	–	16.60	0.6535	12.2
R96021/32	21/32	16.67	0.6563	12.2
R96016.7	–	16.70	0.6575	12.2
R96017.0	–	17.00	0.6693	12.2
R96043/64	43/64	17.07	0.6719	12.2
R96017.1	–	17.10	0.6732	12.2
R96017.2	–	17.20	0.6772	12.2
R96011/16	11/16	17.46	0.6875	12.2
R96017.5	–	17.50	0.6890	12.2
R96017.6	–	17.60	0.6929	12.9
R96017.7	–	17.70	0.6969	12.9

Product	DC	DC	DC	LH
	(inch)	(mm)	(inch)	(mm)
R96045/64	45/64	17.86	0.7031	12.9
R96018.0	–	18.00	0.7087	12.9
R96018.1	–	18.10	0.7126	12.9
R96018.2	–	18.20	0.7165	12.9
R96023/32	23/32	18.26	0.7188	12.9
R96018.5	–	18.50	0.7283	12.9
R96018.6	–	18.60	0.7323	13.5
R96047/64	47/64	18.65	0.7344	13.5
R96018.7	–	18.70	0.7362	13.5
R96018.9	–	18.90	0.7441	13.5
R96019.0	–	19.00	0.7480	13.5
R9603/4	3/4	19.05	0.7500	13.5
R96019.1	–	19.10	0.7520	13.5
R96019.2	–	19.20	0.7559	13.5
R96019.25	–	19.25	0.7579	13.5
R96019.3	–	19.30	0.7598	13.5
R96019.35	–	19.35	0.7618	13.5
R96049/64	49/64	19.45	0.7656	13.5
R96019.5	–	19.50	0.7677	13.5
R96019.6	–	19.60	0.7717	14.1
R96019.7	–	19.70	0.7756	14.1
R96025/32	25/32	19.84	0.7813	14.1
R96020.0	–	20.00	0.7874	14.1
R96051/64	51/64	20.24	0.7969	14.1
R96020.5	–	20.50	0.8071	14.1
R96013/16	13/16	20.64	0.8125	14.8
R96021.0	–	21.00	0.8268	14.8
R96053/64	53/64	21.03	0.8281	14.8
R96027/32	27/32	21.43	0.8438	14.8
R96021.5	–	21.50	0.8465	14.8
R96055/64	55/64	21.83	0.8594	15.0
R96022.0	–	22.00	0.8661	15.0
R9607/8	7/8	22.22	0.8750	15.0
R96022.5	–	22.50	0.8858	15.0
R96057/64	57/64	22.62	0.8906	15.0
R96022.7	–	22.70	0.8937	15.0

Product	DC	DC	DC	LH
	(inch)	(mm)	(inch)	(mm)
R96023.0	–	23.00	0.9055	15.1
R96029/32	29/32	23.02	0.9063	15.1
R96059/64	59/64	23.42	0.9219	15.1
R96023.5	–	23.50	0.9252	15.1
R96015/16	15/16	23.81	0.9375	15.4
R96024.0	–	24.00	0.9449	15.4
R96061/64	61/64	24.21	0.9531	15.4
R96024.5	–	24.50	0.9646	15.4
R96031/32	31/32	24.61	0.9688	15.4
R96025.0	–	25.00	0.9844	15.8
R96063/64	63/64	25.00	0.9844	15.8
R9601	1"	25.40	1.0000	15.8
R96025.5	–	25.50	1.0039	15.8
R96025.65	–	25.65	1.0098	15.8
R9601.1/64	1.1/64	25.80	1.0156	15.8
R96026.0	–	26.00	1.0236	16.4
R9601.1/32	1.1/32	26.19	1.0313	16.4
R96026.5	–	26.50	1.0433	16.4
R9601.3/64	1.3/64	26.59	1.0469	16.4
R9601.1/16	1.1/16	26.99	1.0625	17.1
R96027.0	–	27.00	1.0630	17.1
R9601.5/64	1.5/64	27.38	1.0781	17.1
R96027.5	–	27.50	1.0827	17.1
R9601.3/32	1.3/32	27.78	1.0938	17.1
R96028.0	–	28.00	1.1024	17.7
R9601.7/64	1.7/64	28.18	1.1094	17.7
R96028.5	–	28.50	1.1220	17.7
R9601.1/8	1.1/8	28.58	1.1250	17.7
R9601.9/64	1.9/64	28.97	1.1406	18.3
R96029.0	–	29.00	1.1417	18.3
R9601.5/32	1.5/32	29.37	1.1563	18.3
R96029.5	–	29.50	1.1614	18.3
R9601.11/64	1.11/64	29.77	1.1719	18.3
R96030.0	–	30.00	1.1811	19.0
R9601.3/16	1.3/16	30.16	1.1875	19.0
R96030.5	–	30.50	1.2008	19.0



H860

DORMER



Vis HYDRA

Vis de remplacement utilisées pour maintenir solidement les têtes HYDRA en place.

HYDRA

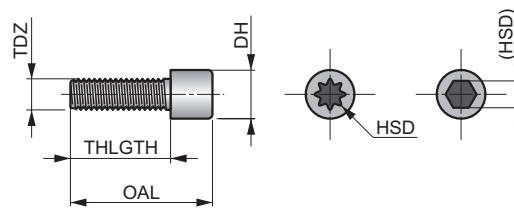

Product	Nr.	TDZ	OAL	THLGTH	DH	HSD
			(mm)	(mm)	(mm)	
H860N1	1	M2.2	7.5	5.70	3.5	8IP
H860N2	2	M2.5	9.0	7.00	4.1	10IP
H860N3	3	M3.0	10.5	8.00	4.9	15IP
H860N4	4	M3.5	11.5	8.80	5.5	15IP
H860N5	5	M4.0	12.5	9.50	6.0	20IP
H860N6	6	M4.5	14.3	10.80	6.8	25IP
H860N7	7	M5.0	20.0	15.00	8.5	4

H861

DORMER



Tournevis HYDRA





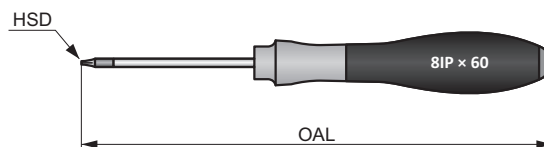





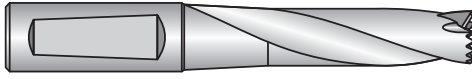

Tournevis utilisés pour serrer les vis HYDRA.

HYDRA



Product	Nr.	HSD	OAL
			(mm)
H861N1	N1	8IP	164.0
H861N2	N2	10IP	191.0
H861N3	N3	15IP	191.0
H861N4	N4	20IP	218.0
H861N5	N5	25IP	218.0

FORETS HAUTE PERFORMANCE À TÊTE INTERCHANGEABLE

Configuration									
	DC	H851 1.5×D	H853 3×D	H855 5×D	H858 8×D	H8512 12×D	R950	R960	H860
Plage	12.00 – 30.50 15/32" – 1.3/16"	12.00 – 42.50 15/32" – 1.5/8"	12.00 – 42.50 15/32" – 1.5/8"	13.50 – 42.50 35/64" – 1.5/8"	13.50 – 25.65 35/64" – 1.1/64"	12.00 – 42.00 15/32" – 1.5/8"	12.00 – 30.50 15/32" – 1.3/16"	N1 – N7	N1 – N6
Pages	 218	 219	 221	 223	 224	 225	 227	 229	 229

DC	H851 1.5×D	H853 3×D	H855 5×D	H858 8×D	H8512 12×D	R950	R960	H860	H861
15/32"						R95015/32	R96015/32		
12.0						R95012.0	R96012.0		
12.1	H85112.0	H85312.0	H85512.0	-	-	R95012.1	R96012.1		
12.2	H85131/64	H85331/64	H85531/64			R95012.2	R96012.2		
31/64"						R95031/64	R96031/64		
12.5						R95012.5	R96012.5		
12.6						R95012.6	R96012.6		
1/2"	H85112.5	H85312.5	H85512.5	-	-	R9501/2	R9601/2		
12.8						R95012.8	R96012.8		
12.9						R95012.9	R96012.9		
13.0						R95013.0	R96013.0		
33/64"	H85113.0	H85313.0	H85513.0	-	-	R95033/64	R96033/64		
13.2	H85117/32	H85317/32	H85517/32			R95013.2	R96013.2		
17/32"						R95017/32	R96017/32		
13.5						R95013.5	R96013.5		
13.6						R95013.6	R96013.6		
13.7						R95013.7	R96013.7		
13.8						R95013.8	R96013.8	H860N1	H861N1
35/64"	H85114.0	H85314.0	H85514.0	H85814.0	H851214.0	R95035/64	R96035/64		
14.0		H85339/16	H85539/16			R95014.0	R96014.0		
14.1						R95014.1	R96014.1		
14.2						R95014.2	R96014.2		
9/16"						R9509/16	R9609/16		
14.5						R95014.5	R96014.5		
14.6						R95014.6	R96014.6		
37/64"						R95037/64	R96037/64		
14.7						R95014.7	R96014.7		
14.8						R95014.8	R96014.8		
15.0						R95015.0	R96015.0		
19/32"	H85115.0	H85315.0	H85515.0	H85815.0	H851215.0	R95019/32	R96019/32		
15.1	H85139/64	H85339/64	H85539/64			R95015.1	R96015.1		
15.2						R95015.2	R96015.2		
15.24						R95015.24	R96015.24		
39/64"						R95039/64	R96039/64		
15.5						R95015.5	R96015.5		

FORETS HAUTE PERFORMANCE À TÊTE INTERCHANGEABLE

DC	H851 1.5xD	H853 3xD	H855 5xD	H858 8xD	H8512 12xD	R950	R960	H860	H861		
15.6						R95015.6	R96015.6				
15.7						R95015.7	R96015.7				
5/8"						R9505/8	R9605/8				
16.0						R95016.0	R96016.0				
16.08	H85116.0	H85316.0	H85516.0	H85816.0	H851216.0	R95016.08	R96016.08				
16.1	H85141/64	H85341/64	H85541/64			R95016.1	R96016.1				
16.2						R95016.2	R96016.2				
16.3						R95016.3	R96016.3				
41/64"						R95041/64	R96041/64				
16.5						R95016.5	R96016.5				
16.6						R95016.6	R96016.6				
21/32"						R95021/32	R96021/32				
16.7						R95016.7	R96016.7				
17.0	H85117.0	H85317.0	H85517.0	H85817.0	H851217.0	R95017.0	R96017.0			H860N2	H861N2
43/64"	H85111/16	H85311/16	H85511/16			R95043/64	R96043/64				
17.1						R95017.1	R96017.1				
17.2						R95017.2	R96017.2				
11/16"						R95011/16	R96011/16				
17.5						R95017.5	R96017.5				
17.6						R95017.6	R96017.6				
17.7						R95017.7	R96017.7				
45/64"	H85118.0	H85318.0	H85518.0	H85818.0	H851218.0	R95045/64	R96045/64				
18.0	H85123/32	H85323/32	H85523/32			R95018.0	R96018.0				
18.1						R95018.1	R96018.1				
18.2						R95018.2	R96018.2				
23/32"						R95023/32	R96023/32				
18.5						R95018.5	R96018.5				
18.6						R95018.6	R96018.6				
47/64"						R95047/64	R96047/64				
18.7						R95018.7	R96018.7				
18.9						R95018.9	R96018.9				
19.0						R95019.0	R96019.0				
3/4"	H85119.0	H85319.0	H85519.0	H85819.0	H851219.0	R9503/4	R9603/4	H860N3			
19.1	H85149/64	H85349/64	H85549/64			R95019.1	R96019.1				
19.2						R95019.2	R96019.2				
19.25						R95019.25	R96019.25				
19.3						R95019.3	R96019.3				
19.35						R95019.35	R96019.35				
49/64"						R95049/64	R96049/64				
19.5						R95019.5	R96019.5				
19.6						R95019.6	R96019.6				
19.7						R95019.7	R96019.7				
25/32"	H85120.0	H85320.0	H85520.0	H85820.0	H851220.0	R95025/32	R96025/32				
20.0	H85151/64	H85351/64	H85551/64			R95020.0	R96020.0				
51/64"						R95051/64	R96051/64				
20.5						R95020.5	R96020.5				
13/16"						R95013/16	R96013/16				
21.0	H85121.0	H85321.0	H85521.0	H85821.0	H851221.0	R95021.0	R96021.0	H861N3			
53/64"	H85127/32	H85327/32	H85527/32			R95053/64	R96053/64				
27/32"						R95027/32	R96027/32				
21.5						R95021.5	R96021.5				
55/64"						R95055/64	R96055/64				
22.0						R95022.0	R96022.0				
7/8"	H85122.0	H85322.0	H85522.0	H85822.0	H851222.0	R9507/8	R9607/8			H860N4	
22.5	H85157/64	H85357/64	H85557/64			R95022.5	R96022.5				
57/64"						R95057/64	R96057/64				
22.7						R95022.7	R96022.7				
23.0						R95023.0	R96023.0				
29/32"	H85123.0	H85323.0	H85523.0	H85823.0	H851223.0	R95029/32	R96029/32				
59/64"	H85159/64	H85359/64	H85559/64			R95059/64	R96059/64				
23.5						R95023.5	R96023.5				

FORETS HAUTE PERFORMANCE À TÊTE INTERCHANGEABLE

DC	H851 1.5xD	H853 3xD	H855 5xD	H858 8xD	H8512 12xD	R950	R960	H860	H861
15/16	H85124.0 H85131/32	H85324.0 H85331/32	H85524.0 H85531/32	H85824.0	H851224.0	R95015/16	R96015/16	H860N4	H861N3
24.0						R95024.0	R96024.0		
61/64						R95061/64	R96061/64		
24.5						R95024.5	R96024.5		
31/32"						R95031/32	R96031/32		
25.0	H85125.0 H8511.1/64	H85325.0 H8531.1/64	H85525.0 H8551.1/64	H85825.0	H851225.0	R95025.0	R96025.0	H860N5	H861N4
63/64"						R95063/64	R96063/64		
1"						R9501	R9601		
25.5						R95025.5	R96025.5		
25.6						R95025.6	–		
25.65						R95025.65	R96025.65		
1.1/64"						R9501.1/64	R9601.1/64		
26.0	H85126.0 H8511.3/64	H85326.0 H8531.3/64	H85526.0 H8551.3/64	H85826.0	–	R95026.0	R96026.0	H860N6	H861N5
1.1/32"						R9501.1/32	R9601.1/32		
26.5						R95026.5	R96026.5		
1.3/64						R9501.3/64	R9601.3/64		
1.1/16"	H85127.0 H8511.3/32	H85327.0 H8531.3/32	H85527.0 H8551.3/32	H85827.0	–	R9501.1/16	R9601.1/16	H860N7	H861N6
27.0						R95027.0	R96027.0		
1.5/64"						R9501.5/64	R9601.5/64		
27.5						R95027.5	R96027.5		
1.3/32"						R9501.3/32	R9601.3/32		
28.0	H85128.0	H85328.0 H8531.1/8	H85528.0 H8551.1/8	H85828.0	–	R95028.0	R96028.0	H860N8	H861N7
1.7/64"						R9501.7/64	R9601.7/64		
28.5						R95028.5	R96028.5		
1.1/8"						R9501.1/8	R9601.1/8		
1.9/64"	H85129.0	H85329.0 H8531.11/64	H85529.0 H8551.11/64	H85829.0	–	R9501.9/64	R9601.9/64	H860N9	H861N8
29.0						R95029.0	R96029.0		
1.5/32"						R9501.5/32	R9601.5/32		
29.5						R95029.5	R96029.5		
1.11/64"						R9501.11/64	R9601.11/64		
30.0	H85130.0 H8511.3/16	H85330.0 H8531.3/16	H85530.0 H8551.3/16	H85830.0	–	R95030.0	R96030.0	H860N10	H861N9
1.3/16"						R9501.3/16	R9601.3/16		
30.5	–	H85332.0	H85532.0	H85832.0	–	R95030.5	R96030.5	H860N11	H861N10
1.7/32"						R9501.7/32	–		
31.0						R95031.0	–		
1.1/4"						R9501.1/4	–		
32.0						R95032.0	–		
32.5	–	H85333.5	H85533.5	H85833.5	–	R95032.5	–	H860N12	H861N11
1.19/64"						R9501.19/64	–		
33.0						R95033.0	–		
33.5						R95033.5	–		
34.0	–	H85335.0	H85535.0	H85835.0	–	R95034.0	–	H860N13	H861N12
1.11/32"						R9501.11/32	–		
34.5						R95034.5	–		
1.3/8"						R9501.3/8	–		
35.0						R95035.0	–		
36.0	–	H85336.5	H85536.5	H85836.5	–	R95036.0	–	H860N14	H861N13
1.27/64"						R9501.27/64	–		
36.5						R95036.5	–		
37.0	–	H85338.0	H85538.0	H85838.0	–	R95037.0	–	H860N15	H861N14
1.15/32"						R9501.15/32	–		
37.5						R95037.5	–		
38.0						R95038.0	–		
1.1/2"	–	H85339.5	H85539.5	H85839.5	–	R9501.1/2	–	H860N16	H861N15
38.5						R95038.5	–		
1.17/32"						R9501.17/32	–		
39.0						R95039.0	–		
39.5						R95039.5	–		
1.9/16"	–	H85341.0	H85541.0	H85841.0	–	R9501.9/16	–	H860N17	H861N16
40.0						R95040.0	–		
41.0	–	–	–	–	–	R95041.0	–	–	–



FORETS HAUTE PERFORMANCE À TÊTE INTERCHANGEABLE

DC	H851 1.5×D	H853 3×D	H855 5×D	H858 8×D	H8512 12×D	R950	R960	H860	H861
1.5/8"	–	H85342.5	H85542.5	H85842.5	–	R9501.5/8	–	H860N7	–
42.0	–					R95042.0	–		

Accessoires

H860	H861	Gamme têtes Hydra DC			Taille de clé / embout
		Métrique (min. – max.)	Fractions (min. – max.)	Décimal (min. – max.)	
H860N1	H861N1	12.0 mm – 15.5 mm	15/32" – 39/64"	0.4688" – 0.6102"	8IP
H860N2	H861N2	15.6 mm – 18.5 mm	5/8" – 23/32"	0.6142" – 0.7283"	10IP
H860N3	H861N3	18.6 mm – 21.5 mm	47/64" – 27/32"	0.7323" – 0.8465"	15IP
H860N4	H861N3	22.0 mm – 24.5 mm	55/64" – 31/32"	0.8594" – 0.9688"	15IP
H860N5	H861N4	25.0 mm – 27.5 mm	63/64" – 1-3/32"	0.9843" – 1.0938"	20IP
H860N6	H861N5	28.0 mm – 33.5 mm	1-7/64" – 1-19/64"	1.1024" – 1.3189"	25IP
H860N7	–	34.0 mm – 42.0 mm	1-11/32" – 1-5/8"	1.3386" – 1.6535"	4 mm Hex

Code de matériau du corps (BMC)		HSS	HSS	HSS	HSS								
Rapport longueur utile diamètre (ULDR)		2×D	3×D	4×D	5×D								
Revêtement		Bright Ni	Bright Ni	Bright Ni	Bright Ni								
Queue		ISO 9766	ISO 9766	ISO 9766	ISO 9766								
Sens (direction de coupe)		R	R	R	R								
Propriété d'alimentation en liquide de coupe (CSP)													
Tolérance de foret		± 0.05	± 0.05	± 0.05	± 0.05								
Tolérance de perçage *		0/+0.2	0/+0.3	0/+0.4	0/+0.5								
Finition de surface *		2–6 µm	2–6 µm	2–6 µm	2–6 µm								
Code de famille de produits		802D	803D	804D	805D	XPET..AP	SCET..-UD	XPET..AP-SD	SCET..-SD	EP			
		15.0–40.0	15.0–58.0	17.0–58.0	19.0–31.0								
		236	238	241	243	246	245	246	245	247			
P	P1					■	■	■	■				
	P2					■	■	■	■				
	P3					■	■	■	■				
	P4					■	■	■	■				
M	M1							■	■				
	M2							■	■				
	M3							■	■				
	M4							■	■				
K	K1					▣	■	▣	▣				
	K2					▣	■	▣	▣				
	K3					▣	■	▣	▣				
	K4					▣	■	▣	▣				
	K5					▣	■	▣	▣				
N	N1												
	N2												
	N3												
	N4												
	N5												
S	S1							▣	▣				
	S2							▣	▣				
	S3							▣	▣				
	S4							▣	▣				
H	H1												
	H2												

* La tolérance du perçage et de la finition de surface dépendent fortement des caractéristiques de la machine

802D



PRAMET

S







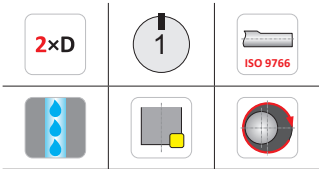
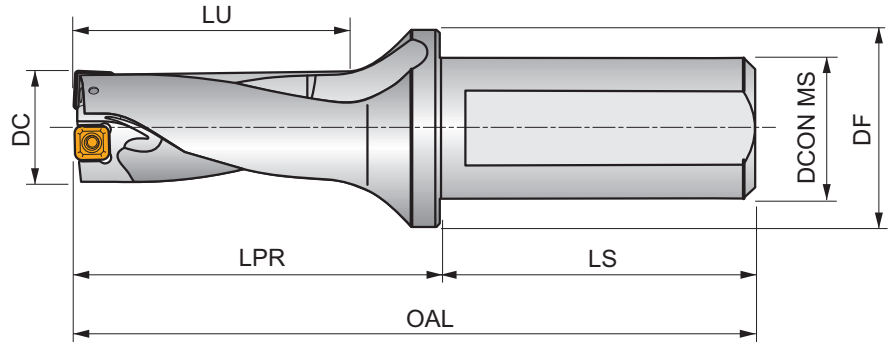



Corps de foret 802D 2xD à plaquettes indexables avec arrosage centralisé

Foret à plaquettes indexables haute performance pour percer des trous borgnes et débouchants. Egalement pour perçage de trous sécants, décentrés et empilés. Interpolation hélicoïdale, tréflage, perçage sur des surfaces concaves ou inclinées, perçage avec coupes interrompues, chanfreinage et alésage.



Product	DC	APMX	OAL	LPR	LS	LU	DCON MS	DF	\bar{D}	D^+					
	(mm)	(mm)	(mm)	(mm)	(mm)	(mm)	(mm)	(mm)	(mm)						
802D-15-30-S25	15	30.00	121	65	56	34.5	25	35	0.25	0.35	EP253253	GI300	GI313	0.32	HM001
802D-16-32-S25	16	32.00	123	67	56	37	25	35	0.15	0.45	EP253253	GI300	GI313	0.32	HM001
802D-17-34-S25	17	34.00	125	69	56	39.5	25	35	0.10	0.50	EP253253	GI300	GI313	0.31	HM001
802D-18-36-S25	18	36.00	127	71	56	42	25	35	0.35	0.25	EP253253	GI301	GI314	0.31	HM002
802D-19-38-S25	19	38.00	129	73	56	44.5	25	35	0.15	0.45	EP253253	GI301	GI314	0.32	HM002
802D-20-40-S25	20	40.00	131	75	56	47	25	35	0.10	0.45	EP253253	GI302	GI315	0.35	HM003
802D-21-42-S25	21	42.00	133	77	56	49.5	25	35	0.10	0.50	EP253253	GI302	GI315	0.34	HM003
802D-22-44-S25	22	44.00	135	79	56	52	25	35	0.45	0.50	EP253253	GI303	GI316	0.35	HM004
802D-23-46-S25	23	46.00	137	81	56	54.5	25	35	0.35	0.50	EP253253	GI304	GI317	0.36	HM005
802D-24-48-S25	24	48.00	139	83	56	57	25	35	0.15	0.50	EP253253	GI304	GI317	0.37	HM005
802D-25-50-S32	25	50.00	145	85	60	57	32	42	0.15	0.50	EP324058	GI304	GI317	0.57	HM005
802D-26-52-S32	26	52.00	147	87	60	59.5	32	42	0.10	0.50	EP324058	GI304	GI317	0.58	HM005
802D-27-54-S32	27	54.00	149	89	60	62	32	42	0.50	0.30	EP324058	GI305	GI318	0.59	HM006
802D-28-56-S32	28	56.00	151	91	60	64.5	32	42	0.30	0.50	EP324058	GI306	GI319	0.61	HM007
802D-29-58-S32	29	58.00	153	93	60	67	32	42	0.20	0.50	EP324058	GI306	GI319	0.62	HM007
802D-30-60-S32	30	60.00	155	95	60	69.5	32	42	0.15	0.50	EP324058	GI306	GI319	0.67	HM007
802D-32-64-S32	32	64.00	159	99	60	70	32	42	0.50	0.35	EP324058	GI307	GI320	0.68	HM008
802D-32-64-S40	32	64.00	167	99	68	70	40	50	0.50	0.35	-	GI307	GI320	1.03	HM008
802D-34-68-S32	34	68.00	163	103	60	75	32	42	0.25	0.50	EP324058	GI307	GI320	0.73	HM008
802D-34-68-S40	34	68.00	171	103	68	75	40	50	0.25	0.50	-	GI307	GI320	1.07	HM008
802D-36-72-S32	36	72.00	167	107	60	80	32	42	0.10	0.50	EP324058	GI308	GI321	0.76	HM009
802D-36-72-S40	36	72.00	173	105	68	77.5	40	50	0.10	0.50	-	GI308	GI321	1.11	HM009
802D-38-76-S32	38	76.00	171	111	60	85	32	42	0.50	0.50	EP324058	GI308	GI321	0.83	HM009
802D-38-76-S40	38	76.00	179	111	68	85	40	50	0.50	0.50	-	GI308	GI321	1.17	HM009
802D-40-80-S32	40	80.00	175	115	60	90	32	42	0.20	0.50	EP324058	GI309	GI322	0.94	HM009
802D-40-80-S40	40	80.00	183	115	68	90	40	50	0.20	0.50	-	GI309	GI322	1.25	HM009

		
GI300	XPET 0502AP	SCET 050204-UD
GI301	XPET 0602AP	SCET 050204-UD
GI302	XPET 0602AP	SCET 060204-UD
GI303	XPET 0703AP	SCET 060204-UD
GI304	XPET 0703AP	SCET 070308-UD
GI305	XPET 0903AP	SCET 070308-UD
GI306	XPET 0903AP	SCET 09T308-UD
GI307	XPET 11T3AP	SCET 09T308-UD
GI308	XPET 11T3AP	SCET 120408-UD
GI309	XPET 12T3AP	SCET 120408-UD
GI313	XPET 0502AP-SD	SCET 050204-SD
GI314	XPET 0602AP-SD	SCET 050204-SD
GI315	XPET 0602AP-SD	SCET 060204-SD
GI316	XPET 0703AP-SD	SCET 060204-SD
GI317	XPET 0703AP-SD	SCET 070308-SD
GI318	XPET 0903AP-SD	SCET 070308-SD
GI319	XPET 0903AP-SD	SCET 09T308-SD
GI320	XPET 11T3AP-SD	SCET 09T308-SD
GI321	XPET 11T3AP-SD	SCET 120408-SD
GI322	XPET 12T3AP-SD	SCET 120408-SD

					
HM001	US 2245-T07P	0.9	US 2245-T07P	0.9	FLAG T07P
HM002	US 2205-T07P	0.9	US 2245-T07P	0.9	FLAG T07P
HM003	US 2205-T07P	0.9	US 2205-T07P	0.9	FLAG T07P
HM004	US 2506-T07P	1.2	US 2506-T07P	1.2	FLAG T07P
HM005	US 2507-T08P	1.2	US 3007-T08P	2.0	FLAG T08P
HM006	US 3007-T09P	2.0	US 3007-T09P	2.0	FLAG T09P
HM007	US 3007-T09P	2.0	US 3009-T09P	2.0	FLAG T09P
HM008	US 3510-T15P	3.0	US 3508-T15P	3.0	FLAG T15P
HM009	US 3510-T15P	3.0	US 5012-T15P	5.0	FLAG T15P

803D



PRAMET

S







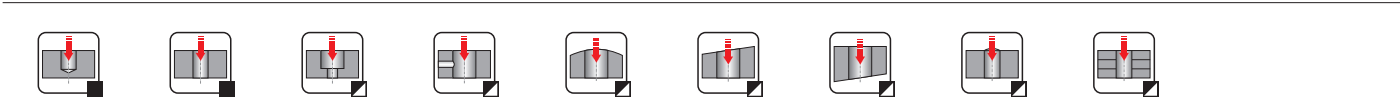
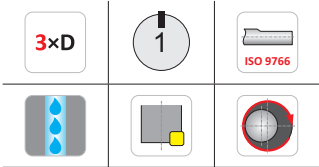
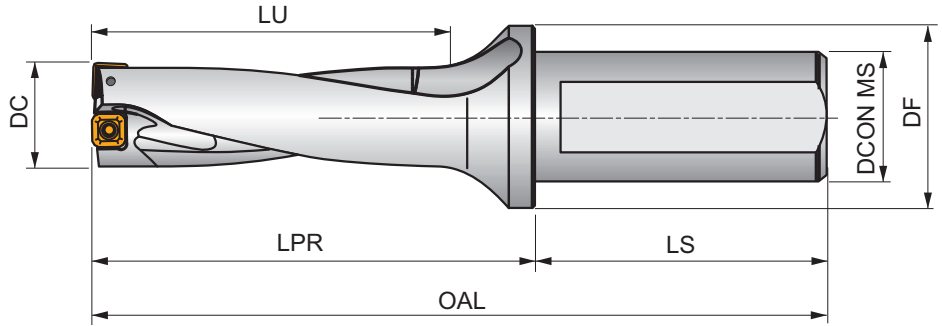



Corps de foret 803D 3xD à plaquettes indexables avec arrosage centralisé



Foret à plaquettes indexables haute performance pour percer des trous borgnes et débouchants. Egalement pour perçage de trous sécants, décentrés et empilés. Interpolation hélicoïdale, tréflage, perçage sur des surfaces concaves ou inclinées, perçage avec coupes interrompues, chanfreinage et alésage.









Product	DC	APMX	OAL	LPR	LS	LU	DCON MS	DF	\bar{D}	D^+					
	(mm)	(mm)	(mm)	(mm)	(mm)	(mm)	(mm)	(mm)	(mm)	(mm)		kg			
803D-15-45-S25	15	45.00	136	80	56	49.5	25	35	0.25	0.35	EP253253	GI300	GI313	0.33	HM001
803D-15,5-46,5-S25	15.5	47.00	137.5	81.5	56	51.2	25	35	0.30	0.35	EP253253	GI300	GI313	0.31	HM001
803D-16-48-S25	16	48.00	139	83	56	53	25	35	0.15	0.45	EP253253	GI300	GI313	0.32	HM001
803D-16,5-49,5-S25	16.5	50.00	140.5	84.5	56	54.7	25	35	0.15	0.40	EP253253	GI300	GI313	0.32	HM001
803D-17-51-S25	17	51.00	142	86	56	56.5	25	35	0.10	0.50	EP253253	GI300	GI313	0.35	HM001
803D-17,5-52,5-S25	17.5	53.00	143.5	87.5	56	58.2	25	35	0.50	0.50	EP253253	GI301	GI314	0.32	HM002
803D-18-54-S25	18	54.00	145	89	56	60	25	35	0.35	0.25	EP253253	GI301	GI314	0.33	HM002
803D-18,5-55,5-S25	18.5	56.00	146.5	90.5	56	61.2	25	35	0.35	0.25	EP253253	GI301	GI314	0.34	HM002
803D-19-57-S25	19	57.00	148	92	56	63.5	25	35	0.15	0.45	EP253253	GI301	GI314	0.34	HM002
803D-19,5-58,5-S25	19.5	59.00	149.5	93.5	56	63.7	25	35	0.25	0.40	EP253253	GI302	GI315	0.34	HM003
803D-20-60-S25	20	60.00	151	95	56	67	25	35	0.10	0.45	EP253253	GI302	GI315	0.33	HM003
803D-20,5-61,5-S25	20.5	62.00	152.5	96.5	56	67.2	25	35	0.10	0.50	EP253253	GI302	GI315	0.36	HM003
803D-21-63-S25	21	63.00	154	98	56	70.5	25	35	0.10	0.50	EP253253	GI302	GI315	0.36	HM003
803D-21,5-64,5-S25	21.5	65.00	155.5	99.5	56	70.8	25	35	0.35	0.50	EP253253	GI303	GI316	0.37	HM004
803D-22-66-S25	22	66.00	157	101	56	74	25	35	0.45	0.50	EP253253	GI303	GI316	0.40	HM004
803D-22,5-67,5-S25	22.5	68.00	158.5	102.5	56	74.3	25	35	0.35	0.50	EP253253	GI304	GI317	0.42	HM005
803D-23-69-S25	23	69.00	160	104	56	77.5	25	35	0.35	0.50	EP253253	GI304	GI317	0.40	HM005
803D-23,5-70,5-S25	23.5	71.00	161.5	105.5	56	77.6	25	35	0.10	0.50	EP253253	GI304	GI317	0.40	HM005
803D-24-72-S25	24	72.00	163	107	56	81	25	35	0.15	0.50	EP253253	GI304	GI317	0.41	HM005
803D-24,5-73,5-S25	24.5	74.00	168.5	108.5	60	78.7	25	35	0.10	0.50	EP253253	GI304	GI317	0.45	HM005
803D-25-75-S32	25	75.00	170	110	60	82	32	42	0.15	0.50	EP324058	GI304	GI317	0.62	HM005
803D-25,5-76,5-S32	25.5	77.00	171.5	111.5	60	82.2	32	42	0.50	0.10	EP324058	GI304	GI317	0.63	HM005
803D-26-78-S32	26	78.00	173	113	60	85.5	32	42	0.10	0.50	EP324058	GI304	GI317	0.66	HM005
803D-26,5-79,5-S32	26.5	80.00	174.5	114.5	60	85.7	32	42	0.50	0.10	EP324058	GI305	GI318	0.67	HM006
803D-27-81-S32	27	81.00	176	116	60	89	32	42	0.50	0.30	EP324058	GI305	GI318	0.65	HM006
803D-28-84-S32	28	84.00	179	119	60	92.5	32	42	0.30	0.50	EP324058	GI306	GI319	0.68	HM007
803D-29-87-S32	29	87.00	182	122	60	96	32	42	0.20	0.50	EP324058	GI306	GI319	0.70	HM007

Product	DC	APMX	OAL	LPR	LS	LU	DCON MS	DF	\bar{D}	D^+					
	(mm)	(mm)	(mm)	(mm)	(mm)	(mm)	(mm)	(mm)	(mm)	(mm)				kg	
803D-30-90-S32	30	90.00	185	125	60	99.5	32	42	0.15	0.50	EP324058	GI306	GI319	0.73	HM007
803D-31-93-S32	31	93.00	188	128	60	103	32	42	0.15	0.50	EP324058	GI306	GI319	0.76	HM007
803D-32-96-S32	32	96.00	191	131	60	102	32	42	0.50	0.30	EP324058	GI307	GI320	0.79	HM008
803D-32-96-S40	32	96.00	199	131	68	102	40	50	0.50	0.30	—	GI307	GI320	1.14	HM008
803D-33-99-S32	33	99.00	194	134	60	105.5	32	42	0.50	0.50	EP324058	GI307	GI320	0.83	HM008
803D-33-99-S40	33	99.00	202	134	68	105.5	40	50	0.50	0.50	—	GI307	GI320	1.18	HM008
803D-34-102-S32	34	102.00	197	137	60	109	32	42	0.25	0.50	EP324058	GI307	GI320	0.86	HM008
803D-34-102-S40	34	102.00	205	137	68	109	40	50	0.25	0.50	—	GI307	GI320	1.12	HM008
803D-35-105-S32	35	105.00	200	140	60	112.5	32	42	0.25	0.50	EP324058	GI308	GI321	0.90	HM009
803D-35-105-S40	35	105.00	208	140	68	112.5	40	50	0.25	0.50	—	GI308	GI321	1.24	HM009
803D-36-108-S32	36	108.00	203	143	60	116	32	42	0.10	0.50	EP324058	GI308	GI321	0.91	HM009
803D-36-108-S40	36	108.00	211	143	68	116	40	50	0.10	0.50	—	GI308	GI321	1.25	HM009
803D-37-111-S32	37	111.00	206	146	60	119.5	32	42	0.10	0.50	EP324058	GI308	GI321	0.95	HM009
803D-37-111-S40	37	111.00	214	146	68	119.5	40	50	0.10	0.50	—	GI308	GI321	1.29	HM009
803D-38-114-S32	38	114.00	199	139	60	124.5	32	42	0.50	0.50	EP324058	GI308	GI321	1.00	HM009
803D-38-114-S40	38	114.00	217	149	68	123	40	50	0.50	0.50	—	GI308	GI321	1.34	HM009
803D-39-117-S32	38	114.00	209	149	60	123	32	42	0.40	0.50	EP324058	GI309	GI322	1.06	HM009
803D-39-117-S40	39	117.00	220	152	68	126.5	40	50	0.40	0.50	—	GI309	GI322	1.40	HM009
803D-40-120-S32	40	120.00	215	155	60	130	32	42	0.20	0.50	EP324058	GI309	GI322	1.12	HM009
803D-40-120-S40	40	120.00	223	155	68	130	40	50	0.20	0.50	—	GI309	GI322	1.46	HM009
803D-41-123-S40	41	123.00	219	149	70	133	40	50	0.20	0.50	—	GI309	GI322	1.48	HM009
803D-42-126-S40	42	126.00	221.5	152	70	136	40	50	0.15	0.50	—	GI309	GI322	1.52	HM009
803D-43-129-S40	43	129.00	224	154	70	139	40	50	0.10	0.50	—	GI309	GI322	1.58	HM009
803D-44-132-S40	44	132.00	226.5	157	70	142	40	50	0.50	0.50	—	GI310	GI323	1.63	HM010
803D-45-135-S40	45	135.00	230.5	161	70	144	40	55	0.50	0.50	—	GI311	GI324	1.73	HM010
803D-46-138-S40	46	138.00	235	165	70	148	40	55	0.50	0.50	—	GI311	GI324	1.82	HM010
803D-47-141-S40	47	141.00	237.5	168	70	151	40	55	0.50	0.50	—	GI311	GI324	1.90	HM010
803D-48-144-S40	48	144.00	240	170	70	154	40	55	0.50	0.50	—	GI311	GI324	1.98	HM010
803D-49-147-S40	49	147.00	242.5	173	70	157	40	55	0.30	0.50	—	GI311	GI324	2.06	HM010
803D-50-150-S40	50	150.00	246.5	177	70	160	40	58	0.15	0.50	—	GI311	GI324	2.18	HM010
803D-51-153-S40	51	153.00	249	179	70	163	40	58	0.15	0.50	—	GI311	GI324	2.24	HM010
803D-52-156-S40	52	156.00	251.5	182	70	166	40	58	0.50	0.50	—	GI312	GI325	2.20	HM010
803D-53-159-S40	53	159.00	254	184	70	169	40	58	0.50	0.50	—	GI312	GI325	2.29	HM010
803D-54-162-S40	54	162.00	257.5	188	70	173	40	58	0.50	0.50	—	GI312	GI325	2.39	HM010
803D-55-165-S40	55	165.00	260	190	70	176	40	58	0.50	0.50	—	GI312	GI325	2.46	HM010
803D-56-168-S40	56	168.00	264	194	70	179	40	58	0.50	0.50	—	GI312	GI325	2.59	HM010
803D-57-171-S40	57	171.00	266.5	197	70	182	40	58	0.35	0.50	—	GI312	GI325	2.70	HM010
803D-58-174-S40	58	174.00	270	200	70	186	40	58	0.15	0.50	—	GI312	GI325	2.83	HM010

		
GI300	XPET 0502AP	SCET 050204-UD
GI301	XPET 0602AP	SCET 050204-UD
GI302	XPET 0602AP	SCET 060204-UD
GI303	XPET 0703AP	SCET 060204-UD
GI304	XPET 0703AP	SCET 070308-UD
GI305	XPET 0903AP	SCET 070308-UD
GI306	XPET 0903AP	SCET 09T308-UD
GI307	XPET 11T3AP	SCET 09T308-UD
GI308	XPET 11T3AP	SCET 120408-UD
GI309	XPET 12T3AP	SCET 120408-UD
GI310	XPET 1504AP	SCET 120408-UD
GI311	XPET 1504AP	SCET 150512-UD
GI312	XPET 1904AP	SCET 150512-UD
GI313	XPET 0502AP-SD	SCET 050204-SD
GI314	XPET 0602AP-SD	SCET 050204-SD
GI315	XPET 0602AP-SD	SCET 060204-SD
GI316	XPET 0703AP-SD	SCET 060204-SD
GI317	XPET 0703AP-SD	SCET 070308-SD
GI318	XPET 0903AP-SD	SCET 070308-SD
GI319	XPET 0903AP-SD	SCET 09T308-SD

		
GI320	XPET 11T3AP-SD	SCET 09T308-SD
GI321	XPET 11T3AP-SD	SCET 120408-SD
GI322	XPET 12T3AP-SD	SCET 120408-SD
GI323	XPET 1504AP-SD	SCET 120408-SD
GI324	XPET 1504AP-SD	SCET 150512-SD
GI325	XPET 1904AP-SD	SCET 150512-SD

		 Nm		 Nm	
HM001	US 2245-T07P	0.9	US 2245-T07P	0.9	FLAG T07P
HM002	US 2205-T07P	0.9	US 2245-T07P	0.9	FLAG T07P
HM003	US 2205-T07P	0.9	US 2205-T07P	0.9	FLAG T07P
HM004	US 2506-T07P	1.2	US 2506-T07P	1.2	FLAG T07P
HM005	US 2507-T08P	1.2	US 3007-T08P	2.0	FLAG T08P
HM006	US 3007-T09P	2.0	US 3007-T09P	2.0	FLAG T09P
HM007	US 3007-T09P	2.0	US 3009-T09P	2.0	FLAG T09P
HM008	US 3510-T15P	3.0	US 3508-T15P	3.0	FLAG T15P
HM009	US 3510-T15P	3.0	US 5012-T15P	5.0	FLAG T15P
HM010	US 4011-T15P	3.5	US 5012-T15P	5.0	FLAG T15P

804D



PRAMET

S







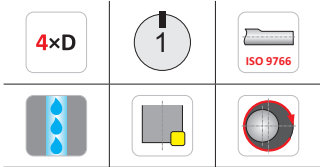
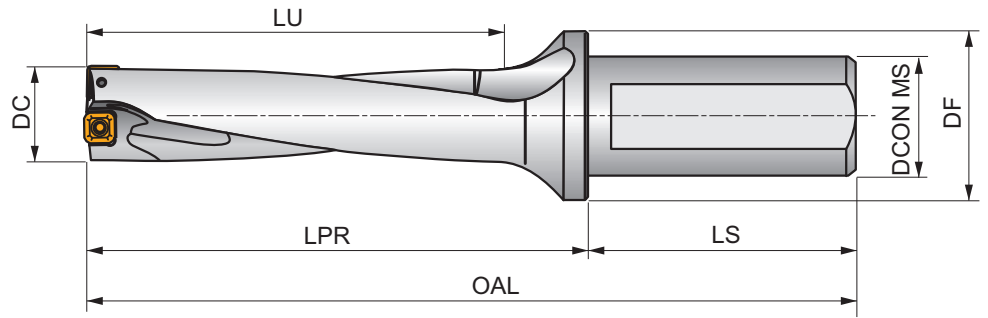



Corps de foret 804D 4xD à plaquettes indexables avec arrosage centralisé







Foret à plaquettes indexables haute performance pour percer des trous borgnes et débouchants. Egalement pour perçage de trous sécants, décentrés et empilés. Interpolation hélicoïdale, tréflage, perçage sur des surfaces concaves ou inclinées, perçage avec coupes interrompues, chanfreinage et alésage.



Product	DC	APMX	OAL	LPR	LS	LU	DCON MS	DF	\bar{D}	\bar{D}^+					
	(mm)	(mm)	(mm)	(mm)	(mm)	(mm)	(mm)	(mm)	(mm)						
804D-17-68-S25	17	68.00	149	93	56	73	25	35	0.10	0.50	–	GI300	GI313	0.34	HM001
804D-18-72-S25	18	72.00	153	97	56	77	25	35	0.35	0.25	–	GI301	GI314	0.35	HM002
804D-19-76-S25	19	76.00	157	101	56	81.5	25	35	0.15	0.45	–	GI301	GI314	0.36	HM002
804D-20-80-S25	20	80.00	161	105	56	85	25	35	0.10	0.45	–	GI302	GI315	0.37	HM003
804D-21-84-S25	21	84.00	165	109	56	89.5	25	35	0.10	0.50	–	GI302	GI315	0.43	HM003
804D-22-88-S25	22	88.00	169	113	56	94	25	35	0.45	0.50	–	GI303	GI316	0.45	HM004
804D-23-92-S25	23	92.00	173	117	56	98.5	25	35	0.35	0.50	–	GI304	GI317	0.44	HM005
804D-24-96-S25	24	96.00	177	121	56	103	25	35	0.15	0.50	–	GI304	GI317	0.45	HM005
804D-25-100-S32	25	100.00	185	125	60	105	32	42	0.15	0.50	–	GI304	GI317	0.67	HM005
804D-26-104-S32	26	104.00	189	129	60	109.5	32	42	0.10	0.50	–	GI304	GI317	0.70	HM005
804D-27-108-S32	27	108.00	193	133	60	114	32	42	0.50	0.30	–	GI305	GI318	0.71	HM006
804D-28-112-S32	28	112.00	197	137	60	118.5	32	42	0.30	0.50	–	GI306	GI319	0.75	HM007
804D-29-116-S32	29	116.00	201	141	60	123	32	42	0.20	0.50	–	GI306	GI319	0.78	HM007
804D-30-120-S32	30	120.00	205	145	60	127.5	32	42	0.15	0.50	–	GI306	GI319	0.82	HM007
804D-31-124-S32	31	124.00	209	149	60	132	32	42	0.15	0.50	–	GI306	GI319	0.85	HM007
804D-32-128-S32	32	128.00	213	153	60	136.5	32	42	0.50	0.30	–	GI307	GI320	0.90	HM008
804D-33-132-S32	33	132.00	217	157	60	141	32	42	0.50	0.50	–	GI307	GI320	0.95	HM008
804D-34-136-S32	34	136.00	221	161	60	145.5	32	42	0.25	0.50	–	GI307	GI320	0.99	HM008
804D-35-140-S32	35	140.00	225	165	60	149	32	42	0.25	0.50	–	GI308	GI321	1.04	HM009
804D-36-144-S32	36	144.00	229	169	60	153.5	32	42	0.10	0.50	–	GI308	GI321	1.05	HM009
804D-37-148-S32	37	148.00	233	173	60	158	32	42	0.10	0.50	–	GI308	GI321	1.11	HM009
804D-38-152-S32	38	152.00	237	177	60	162.5	32	42	0.50	0.50	–	GI308	GI321	1.18	HM009
804D-39-156-S32	39	156.00	241	181	60	167	32	42	0.40	0.50	–	GI309	GI322	1.25	HM009
804D-40-160-S32	40	160.00	245	185	60	171.5	32	42	0.20	0.50	–	GI309	GI322	1.33	HM009
804D-41-164-S40	41	164.00	259	189	70	172	40	50	0.20	0.50	–	GI309	GI322	1.68	HM009
804D-42-168-S40	42	168.00	263	193	70	176.5	40	50	0.15	0.50	–	GI309	GI322	1.76	HM009
804D-43-172-S40	43	172.00	267	197	70	181	40	50	0.10	0.50	–	GI309	GI322	1.83	HM009

Product	DC	APMX	OAL	LPR	LS	LU	DCON MS	DF	\bar{D}	D^+					
	(mm)	(mm)	(mm)	(mm)	(mm)	(mm)	(mm)	(mm)	(mm)	(mm)				kg	
804D-44-176-S40	44	176.00	271	201	70	185.5	40	50	0.50	0.50	–	GI310	GI323	1.91	HM010
804D-45-180-S40	45	180.00	275	205	70	187.5	40	55	0.50	0.50	–	GI311	GI324	2.02	HM010
804D-46-184-S40	46	184.00	279	209	70	192	40	55	0.50	0.50	–	GI311	GI324	2.12	HM010
804D-47-188-S40	47	188.00	283	213	70	196.5	40	55	0.50	0.50	–	GI311	GI324	2.22	HM010
804D-48-192-S40	48	192.00	287	217	70	201	40	55	0.50	0.50	–	GI311	GI324	2.33	HM010
804D-49-196-S40	49	196.00	291	221	70	205.5	40	55	0.30	0.50	–	GI311	GI324	2.45	HM010
804D-50-200-S40	50	200.00	295	225	70	208.5	40	58	0.15	0.50	–	GI311	GI324	2.58	HM010
804D-51-204-S40	51	204.00	299	229	70	213	40	58	0.15	0.50	–	GI311	GI324	2.68	HM010
804D-52-208-S40	52	208.00	303	233	70	217.5	40	58	0.50	0.50	–	GI312	GI325	2.64	HM010
804D-53-212-S40	53	212.00	307	237	70	222	40	58	0.50	0.50	–	GI312	GI325	2.76	HM010
804D-54-216-S40	54	216.00	311	241	70	226.5	40	58	0.50	0.50	–	GI312	GI325	2.90	HM010
804D-55-220-S40	55	220.00	315	245	70	231	40	58	0.50	0.50	–	GI312	GI325	3.00	HM010
804D-56-224-S40	56	224.00	319	249	70	235.5	40	58	0.50	0.50	–	GI312	GI325	3.15	HM010
804D-57-228-S40	57	228.00	323	253	70	240	40	58	0.35	0.50	–	GI312	GI325	3.30	HM010
804D-58-232-S40	58	232.00	327	257	70	244.5	40	58	0.15	0.50	–	GI312	GI325	3.46	HM010

		
GI300	XPET 0502AP	SCET 050204-UD
GI301	XPET 0602AP	SCET 050204-UD
GI302	XPET 0602AP	SCET 060204-UD
GI303	XPET 0703AP	SCET 060204-UD
GI304	XPET 0703AP	SCET 070308-UD
GI305	XPET 0903AP	SCET 070308-UD
GI306	XPET 0903AP	SCET 09T308-UD
GI307	XPET 11T3AP	SCET 09T308-UD
GI308	XPET 11T3AP	SCET 120408-UD
GI309	XPET 12T3AP	SCET 120408-UD
GI310	XPET 1504AP	SCET 120408-UD
GI311	XPET 1504AP	SCET 150512-UD
GI312	XPET 1904AP	SCET 150512-UD
GI313	XPET 0502AP-SD	SCET 050204-SD
GI314	XPET 0602AP-SD	SCET 050204-SD
GI315	XPET 0602AP-SD	SCET 060204-SD
GI316	XPET 0703AP-SD	SCET 060204-SD
GI317	XPET 0703AP-SD	SCET 070308-SD
GI318	XPET 0903AP-SD	SCET 070308-SD
GI319	XPET 0903AP-SD	SCET 09T308-SD
GI320	XPET 11T3AP-SD	SCET 09T308-SD
GI321	XPET 11T3AP-SD	SCET 120408-SD
GI322	XPET 12T3AP-SD	SCET 120408-SD
GI323	XPET 1504AP-SD	SCET 120408-SD
GI324	XPET 1504AP-SD	SCET 150512-SD
GI325	XPET 1904AP-SD	SCET 150512-SD

					
HM001	US 2245-T07P	0.9	US 2245-T07P	0.9	FLAG T07P
HM002	US 2205-T07P	0.9	US 2245-T07P	0.9	FLAG T07P
HM003	US 2205-T07P	0.9	US 2205-T07P	0.9	FLAG T07P
HM004	US 2506-T07P	1.2	US 2506-T07P	1.2	FLAG T07P
HM005	US 2507-T08P	1.2	US 3007-T08P	2.0	FLAG T08P
HM006	US 3007-T09P	2.0	US 3007-T09P	2.0	FLAG T09P
HM007	US 3007-T09P	2.0	US 3009-T09P	2.0	FLAG T09P
HM008	US 3510-T15P	3.0	US 3508-T15P	3.0	FLAG T15P
HM009	US 3510-T15P	3.0	US 5012-T15P	5.0	FLAG T15P
HM010	US 4011-T15P	3.5	US 5012-T15P	5.0	FLAG T15P

805D



PRAMET







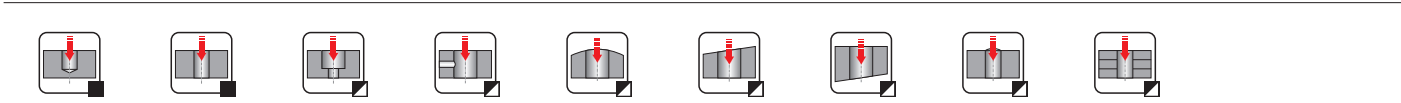
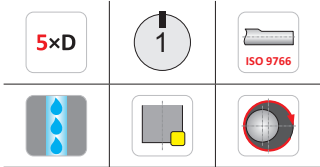
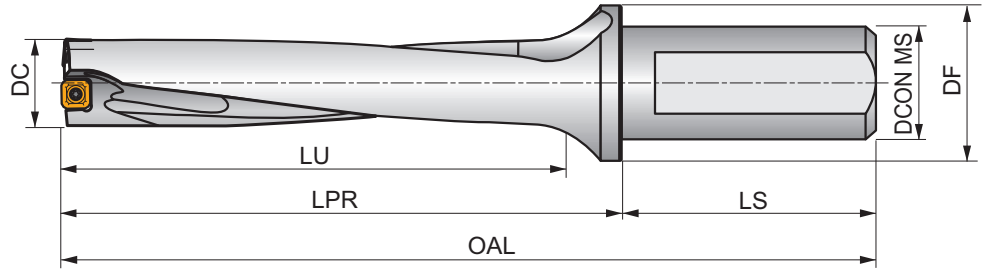

Corps de foret 805D 5xD à plaquettes indexables avec arrosage centralisé

Foret à plaquettes indexables haute performance pour percer des trous borgnes et débouchants. Egalement pour perçage de trous sécants, décentrés et empilés. Interpolation hélicoïdale, tréflage, perçage sur des surfaces concaves ou inclinées, perçage avec coupes interrompues, chanfreinage et alésage.



Product	DC	APMX	OAL	LPR	LS	LU	DCON MS	DF	\bar{D}	\bar{D}^+				kg	
	(mm)	(mm)	(mm)	(mm)	(mm)	(mm)	(mm)	(mm)	(mm)	(mm)					
805D-19-95-S25	19	95.00	176	120	56	100.5	25	35	0.15	0.45	–	GI301	GI314	0.38	HM002
805D-20-100-S25	20	100.00	181	125	56	105	25	35	0.10	0.45	–	GI302	GI315	0.40	HM003
805D-21-105-S25	21	105.00	186	130	56	110.5	25	35	0.10	0.50	–	GI302	GI315	0.42	HM003
805D-22-110-S25	22	110.00	191	135	56	116	25	35	0.45	0.50	–	GI303	GI316	0.45	HM004
805D-23-115-S25	23	115.00	196	140	56	121.5	25	35	0.35	0.50	–	GI304	GI317	0.48	HM005
805D-24-120-S25	24	120.00	201	145	56	127	25	35	0.15	0.50	–	GI304	GI317	0.49	HM005
805D-25-125-S32	25	125.00	210	150	60	130	32	42	0.15	0.50	–	GI304	GI317	0.72	HM005
805D-26-130-S32	26	130.00	215	155	60	135.5	32	42	0.10	0.50	–	GI304	GI317	0.82	HM005
805D-27-135-S32	27	135.00	220	160	60	141	32	42	0.50	0.30	–	GI305	GI318	0.78	HM006
805D-28-140-S32	28	140.00	225	165	60	146.5	32	42	0.30	0.50	–	GI306	GI319	0.82	HM007
805D-29-145-S32	29	145.00	230	170	60	152	32	42	0.20	0.50	–	GI306	GI319	0.86	HM007
805D-30-150-S32	30	150.00	235	175	60	157.5	32	42	0.15	0.50	–	GI306	GI319	0.90	HM007
805D-31-155-S32	31	155.00	240	180	60	163	32	42	0.15	0.50	–	GI306	GI319	0.95	HM007

GI301	XPET 0602AP	SCET 050204-UD
GI302	XPET 0602AP	SCET 060204-UD
GI303	XPET 0703AP	SCET 060204-UD
GI304	XPET 0703AP	SCET 070308-UD
GI305	XPET 0903AP	SCET 070308-UD
GI306	XPET 0903AP	SCET 09T308-UD
GI314	XPET 0602AP-SD	SCET 050204-SD
GI315	XPET 0602AP-SD	SCET 060204-SD
GI316	XPET 0703AP-SD	SCET 060204-SD
GI317	XPET 0703AP-SD	SCET 070308-SD
GI318	XPET 0903AP-SD	SCET 070308-SD
GI319	XPET 0903AP-SD	SCET 09T308-SD

					
HM002	US 2205-T07P	0.9	US 2245-T07P	0.9	FLAG T07P
HM003	US 2205-T07P	0.9	US 2205-T07P	0.9	FLAG T07P
HM004	US 2506-T07P	1.2	US 2506-T07P	1.2	FLAG T07P
HM005	US 2507-T08P	1.2	US 3007-T08P	2.0	FLAG T08P
HM006	US 3007-T09P	2.0	US 3007-T09P	2.0	FLAG T09P
HM007	US 3007-T09P	2.0	US 3009-T09P	2.0	FLAG T09P



SCET



	IC (mm)	D1 (mm)	L (mm)	S (mm)
0502	5.556	2.40	5.56	2.38
0602	6.350	2.90	6.35	2.38
0703	7.937	3.50	7.94	3.18
09T3	9.525	4.50	9.53	3.97
1204	12.700	5.60	12.70	4.76
1505	15.875	5.60	15.88	5.56

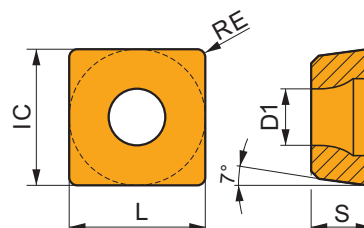

Adéquation et valeurs de départ pour la vitesse de coupe (vc), l'avance (f) et la profondeur de coupe (ap). Reportez-vous à notre application „Calculators“ pour d'autres calculs.

Product	Interrupted/ Continuous cut	RE (mm)	P			M			K			N			S			H		
			vc (m/min)	f (mm/rev)	ap (mm)	vc (m/min)	f (mm/rev)	ap (mm)	vc (m/min)	f (mm/rev)	ap (mm)	vc (m/min)	f (mm/rev)	ap (mm)	vc (m/min)	f (mm/rev)	ap (mm)	vc (m/min)	f (mm/rev)	ap (mm)

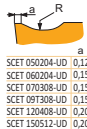

SCET 050204-UD 0.12
 SCET 060204-UD 0.15
 SCET 070308-UD 0.15
 SCET 09T308-UD 0.15
 SCET 120408-UD 0.20
 SCET 150512-UD 0.20



Géométrie SD avec coupe universelle pour plaquettes périphériques.

SCET 050204-UD:D8330	●	0.4	165	0.08	—	—	—	—	155	0.08	—	—	—	—	—	—	—	—	—	—
SCET 050204-UD:D9335	●	0.4	240	0.08	—	—	—	—	225	0.08	—	—	—	—	—	—	—	—	—	—
SCET 060204-UD:D8330	●	0.4	165	0.11	—	—	—	—	155	0.11	—	—	—	—	—	—	—	—	—	—
SCET 060204-UD:D9335	●	0.4	240	0.11	—	—	—	—	225	0.11	—	—	—	—	—	—	—	—	—	—
SCET 070308-UD:D8330	●	0.8	165	0.13	—	—	—	—	155	0.13	—	—	—	—	—	—	—	—	—	—
SCET 070308-UD:D9335	●	0.8	240	0.13	—	—	—	—	225	0.13	—	—	—	—	—	—	—	—	—	—
SCET 09T308-UD:D8330	●	0.8	165	0.14	—	—	—	—	155	0.14	—	—	—	—	—	—	—	—	—	—
SCET 09T308-UD:D9335	●	0.8	240	0.14	—	—	—	—	225	0.14	—	—	—	—	—	—	—	—	—	—
SCET 120408-UD:D8330	●	0.8	165	0.16	—	—	—	—	155	0.16	—	—	—	—	—	—	—	—	—	—
SCET 120408-UD:D9335	●	0.8	240	0.16	—	—	—	—	225	0.16	—	—	—	—	—	—	—	—	—	—
SCET 150512-UD:D8330	●	1.2	165	0.18	—	—	—	—	155	0.18	—	—	—	—	—	—	—	—	—	—
SCET 150512-UD:D9335	●	1.2	240	0.18	—	—	—	—	225	0.18	—	—	—	—	—	—	—	—	—	—

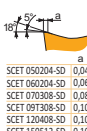

SCET 050204-SD 0.04
 SCET 060204-SD 0.06
 SCET 070308-SD 0.08
 SCET 09T308-SD 0.10
 SCET 120408-SD 0.10
 SCET 150512-SD 0.10



Géométrie SD avec coupe positive pour plaquettes périphériques.

SCET 050204-SD:D8330	●	0.4	165	0.08	—	95	0.07	—	155	0.08	—	—	—	—	40	0.06	—	—	—	—
SCET 050204-SD:D9335	●	0.4	240	0.08	—	140	0.07	—	225	0.08	—	—	—	—	60	0.06	—	—	—	—
SCET 060204-SD:D8330	●	0.4	165	0.11	—	95	0.09	—	155	0.11	—	—	—	—	40	0.07	—	—	—	—
SCET 060204-SD:D9335	●	0.4	240	0.11	—	140	0.09	—	225	0.11	—	—	—	—	60	0.07	—	—	—	—
SCET 070308-SD:D8330	●	0.8	165	0.13	—	95	0.11	—	155	0.13	—	—	—	—	40	0.09	—	—	—	—
SCET 070308-SD:D9335	●	0.8	240	0.13	—	140	0.11	—	225	0.13	—	—	—	—	60	0.09	—	—	—	—
SCET 09T308-SD:D8330	●	0.8	165	0.14	—	95	0.13	—	155	0.14	—	—	—	—	40	0.10	—	—	—	—
SCET 09T308-SD:D9335	●	0.8	240	0.14	—	140	0.13	—	225	0.14	—	—	—	—	60	0.10	—	—	—	—
SCET 120408-SD:D8330	●	0.8	165	0.16	—	95	0.14	—	155	0.16	—	—	—	—	40	0.11	—	—	—	—
SCET 120408-SD:D9335	●	0.8	240	0.16	—	140	0.14	—	225	0.16	—	—	—	—	60	0.11	—	—	—	—
SCET 150512-SD:D8330	●	1.2	165	0.18	—	95	0.16	—	155	0.18	—	—	—	—	40	0.12	—	—	—	—
SCET 150512-SD:D9335	●	1.2	240	0.18	—	140	0.16	—	225	0.18	—	—	—	—	60	0.12	—	—	—	—

XPET



	IC (mm)	D1 (mm)	L (mm)	S (mm)
0502	5.556	2.40	5.56	2.38
0602	6.350	2.60	6.35	2.38
0703	7.937	2.90	7.94	3.18
0903	9.525	3.50	9.53	3.18
11T3	11.509	3.90	11.50	3.97
12T3	12.700	3.90	12.70	3.97
1504	15.875	4.50	15.88	4.76
1904	19.050	4.50	19.05	4.76

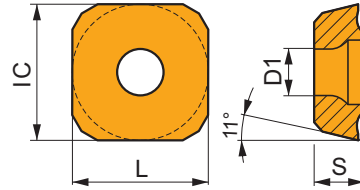

Adéquation et valeurs de départ pour la vitesse de coupe (vc), l'avance (f) et la profondeur de coupe (ap). Reportez-vous à notre application „Calculators“ pour d'autres calculs.

Product	Incrum/rev/ Continuous cut (mm)	RE (mm)	P			M			K			N			S			H		
			vc (m/min)	f (mm/rev)	ap (mm)	vc (m/min)	f (mm/rev)	ap (mm)	vc (m/min)	f (mm/rev)	ap (mm)	vc (m/min)	f (mm/rev)	ap (mm)	vc (m/min)	f (mm/rev)	ap (mm)	vc (m/min)	f (mm/rev)	ap (mm)



XPET 0502AP	0,10
XPET 0602AP	0,10
XPET 0703AP	0,15
XPET 0903AP	0,25
XPET 11T3AP	0,25
XPET 12T3AP	0,25
XPET 1504AP	0,25
XPET 1904AP	0,25



Géométrie avec coupe universelle pour plaquettes centrales.

XPET 0502AP:D8345	☹	—	■	165	0.08	—	■	—	—	—	■	155	0.08	—	■	—	—	—	■	—	—	—	■	—	—	—
XPET 0602AP:D8345	☹	—	■	165	0.11	—	■	—	—	—	■	155	0.11	—	■	—	—	—	■	—	—	—	■	—	—	—
XPET 0703AP:D8345	☹	—	■	165	0.13	—	■	—	—	—	■	155	0.13	—	■	—	—	—	■	—	—	—	■	—	—	—
XPET 0903AP:D8345	☹	—	■	165	0.14	—	■	—	—	—	■	155	0.14	—	■	—	—	—	■	—	—	—	■	—	—	—
XPET 11T3AP:D8345	☹	—	■	165	0.16	—	■	—	—	—	■	155	0.16	—	■	—	—	—	■	—	—	—	■	—	—	—
XPET 12T3AP:D8345	☹	—	■	165	0.16	—	■	—	—	—	■	155	0.16	—	■	—	—	—	■	—	—	—	■	—	—	—
XPET 1504AP:D8345	☹	—	■	165	0.18	—	■	—	—	—	■	155	0.18	—	■	—	—	—	■	—	—	—	■	—	—	—
XPET 1904AP:D8345	☹	—	■	165	0.18	—	■	—	—	—	■	155	0.18	—	■	—	—	—	■	—	—	—	■	—	—	—

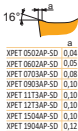

XPET 0502AP-SD	0,04
XPET 0602AP-SD	0,05
XPET 0703AP-SD	0,08
XPET 0903AP-SD	0,10
XPET 11T3AP-SD	0,10
XPET 12T3AP-SD	0,10
XPET 1504AP-SD	0,10
XPET 1904AP-SD	0,12



Géométrie SD avec coupe positive pour plaquettes centrales.

XPET 0502AP-SD:D8345	☹	—	■	165	0.08	—	■	95	0.07	—	■	155	0.08	—	■	40	0.06	—	■	—	—	—	■	—	—	—
XPET 0602AP-SD:D8345	☹	—	■	165	0.11	—	■	95	0.09	—	■	155	0.11	—	■	40	0.07	—	■	—	—	—	■	—	—	—
XPET 0703AP-SD:D8345	☹	—	■	165	0.13	—	■	95	0.11	—	■	155	0.13	—	■	40	0.09	—	■	—	—	—	■	—	—	—
XPET 0903AP-SD:D8345	☹	—	■	165	0.14	—	■	95	0.13	—	■	155	0.14	—	■	40	0.10	—	■	—	—	—	■	—	—	—
XPET 11T3AP-SD:D8345	☹	—	■	165	0.16	—	■	95	0.14	—	■	155	0.16	—	■	40	0.11	—	■	—	—	—	■	—	—	—
XPET 12T3AP-SD:D8345	☹	—	■	165	0.16	—	■	95	0.14	—	■	155	0.16	—	■	40	0.11	—	■	—	—	—	■	—	—	—
XPET 1504AP-SD:D8345	☹	—	■	165	0.18	—	■	95	0.16	—	■	155	0.18	—	■	40	0.12	—	■	—	—	—	■	—	—	—
XPET 1904AP-SD:D8345	☹	—	■	165	0.18	—	■	95	0.16	—	■	155	0.18	—	■	40	0.12	—	■	—	—	—	■	—	—	—



EP

PRAMET



EP - Douille de réglage de foret à plaquettes indexables

Douille pour ajuster le diamètre du foret à plaquettes indexables. Peut être utilisée dans les porte-outils weldon Ø32, Ø40 ou Ø50 mm. Le diamètre extérieur du foret est ajusté en tournant la douille.

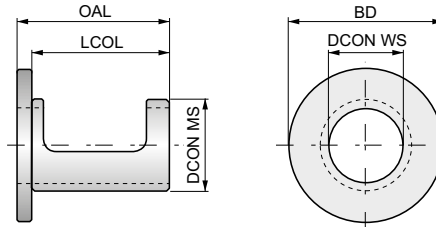

Plage de réglage du diamètre 0.4 – -0.2; plage de réglage de la hauteur de centre 0.2 – -0.15.

Product	DCON WS	DCON MS	BD	OAL	LCOL	
	(mm)	(mm)	(mm)	(mm)	(mm)	
EP253253	25.00	32.00	53.00	53.0	48	0.15
EP324058	32.00	40.00	58.00	58.0	53	0.19
EP405085-F	40.00	50.00	76.00	85.0	80	0.25

Code de matériau du corps (BMC)	HM	HM	HM	HM	HM										
Revêtement	Bright	Bright	Bright	Bright	Bright										
Groupe standard de base (BSG)	DIN 8093	DIN 8093	DIN 8050	DIN 8094	DIN 8051										
Sens (direction de coupe)	R	R	R	R	R										
Queue															
Forme d'alésoir	B	B	A	B	A										
Tolérance de trou réalisable (TCHA)	H7	$\begin{matrix} \phi 95.5.5 \\ +0.004 \\ \phi 5.51-12 \\ +0.005 \end{matrix}$	H7	H7	H7										



Code de famille de produits Plage de diamètres de coupe PSF		B400	B481	B441	B411	B442										
		1.00 - 20.00	0.98 - 12.05	10.00 - 20.00	5.00 - 30.00	10.00 - 20.00										
		250	251	253	254	255										
P	P1	■	■	■	■	■										
	P2	■	■	■	■	■										
	P3	■	■	■	■	■										
	P4	■	■	■	■	■										
M	M1	▣	▣	▣	▣	▣										
	M2	▣	▣	▣	▣	▣										
	M3															
	M4															
K	K1	■	■	■	■	■										
	K2	■	■	■	■	■										
	K3	■	■	■	■	■										
	K4															
	K5	■	■	■	■	■										
N	N1	■	■	■	■	■										
	N2	■	■	■	■	■										
	N3	■	■	■	■	■										
	N4	▣	▣	▣	▣	▣										
	N5															
S	S1															
	S2															
	S3															
	S4															
H	H1															
	H2															
	H3															
	H4															

B400



Alésoir machine en carbure à queue cylindrique, précision H7, finition brillante

Alésoir conçu pour fournir une finition dans les limites de la tolérance des trous H7. Offre des performances supérieures et une durée de vie prolongée de l'outil lors de l'alésage de matériaux durs et abrasifs. La conception des goujures en spirale espacées inégalement réduit les vibrations et améliore la cylindricité, la taille et la finition de surface des trous.

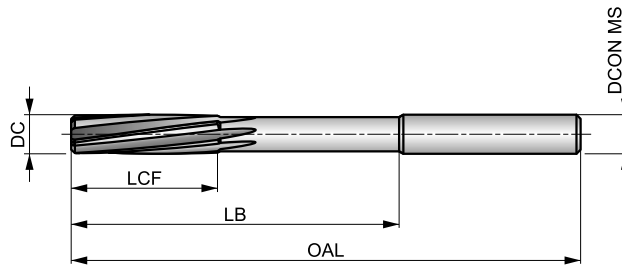

HM	Bright	DIN 8093
R		B
H7		

Adéquation du groupe de matériaux de la pièce, valeurs de départ pour la vitesse de coupe (m/min) et code Alpha d'avance. Les tableaux d'avances par tour se trouvent à partir de la page 279.

P1.1 ■ 23 B	P1.2 ■ 26 B	P1.3 ■ 27 B	P2.1 ■ 20 B	P2.2 ■ 18 B	P2.3 ■ 16 C	P3.1 ■ 16 B	P3.2 ■ 13 B	P3.3 ■ 11 C	P4.1 ■ 10 B	P4.2 ■ 8 C	P4.3 ■ 7 C	M1.1 ▣ 10 C	M1.2 ▣ 8 C
M2.1 ▣ 9 C	M2.2 ▣ 17 C	M2.3 ▣ 16 B	K1.1 ■ 20 D	K1.2 ■ 15 D	K1.3 ■ 11 D	K2.1 ■ 21 D	K2.2 ■ 17 D	K2.3 ■ 14 D	K3.1 ■ 18 D	K3.2 ■ 14 D	K3.3 ■ 11 D	K5.1 ■ 19 D	K5.2 ■ 15 D
K5.3 ■ 11 D	N1.1 ▣ 60 D	N1.2 ■ 45 D	N1.3 ■ 30 D	N2.1 ■ 38 D	N2.2 ■ 35 D	N2.3 ■ 25 D	N3.1 ■ 64 E	N3.2 ■ 38 E	N3.3 ▣ 19 E	N4.1 ▣ 35 C	N4.2 ▣ 30 C		

DCON MS tolerance h6; DC >= 14 mm pointe carbure.

Product	DC (mm)	OAL (mm)	LCF (mm)	LB (mm)	NOF	DCON MS (mm)
B4001.0	1.00	34.0	5.5	15.00	3	1.00
B4001.2	1.20	38.0	7.5	16.50	3	1.20
B4001.4	1.40	40.0	8.0	18.00	3	1.50
B4001.5	1.50	40.0	8.0	18.00	3	1.50
B4001.6	1.60	43.0	9.0	20.00	3	1.60
B4001.8	1.80	46.0	10.0	22.00	4	1.80
B4002.0	2.00	49.0	11.0	24.00	4	2.00
B4002.2	2.20	53.0	12.0	25.00	4	2.20
B4002.5	2.50	57.0	14.0	29.00	4	2.50
B4002.8	2.80	61.0	15.0	33.00	6	3.00
B4003.0	3.00	61.0	15.0	33.00	6	3.00
B4003.2	3.20	65.0	16.0	37.00	6	3.20
B4003.5	3.50	70.0	18.0	42.00	6	3.50
B4004.0	4.00	75.0	19.0	47.00	6	4.00

Product	DC (mm)	OAL (mm)	LCF (mm)	LB (mm)	NOF	DCON MS (mm)
B4004.5	4.50	80.0	21.0	52.00	6	4.50
B4005.0	5.00	86.0	23.0	58.00	6	5.00
B4005.5	5.50	93.0	26.0	57.00	6	5.60
B4006.0	6.00	93.0	26.0	57.00	6	5.60
B4006.5	6.50	101.0	28.0	65.00	6	6.30
B4007.0	7.00	109.0	31.0	73.00	6	7.10
B4008.0	8.00	117.0	33.0	81.00	6	8.00
B4009.0	9.00	125.0	36.0	85.00	6	9.00
B40010.0	10.00	133.0	38.0	93.00	6	10.00
B40012.0	12.00	151.0	44.0	111.00	6	10.00
B40014.0	14.00	160.0	47.0	115.00	6	12.50
B40016.0	16.00	170.0	52.0	125.00	6	12.50
B40018.0	18.00	182.0	56.0	137.00	6	14.00
B40020.0	20.00	195.0	60.0	147.00	6	16.00

B481



Alésoir machine en carbure à queue cylindrique - Incréments de 0,01 mm, finition brillante

Alésoir à queue cylindrique pour de hautes performances en usinage CNC. Les arêtes en carbure de première qualité améliorent considérablement les performances et prolongent la durée de vie de l'outil lors de l'alésage de matériaux durs et abrasifs. Espacement extrêmement inégal des goujures pour réduire les vibrations.

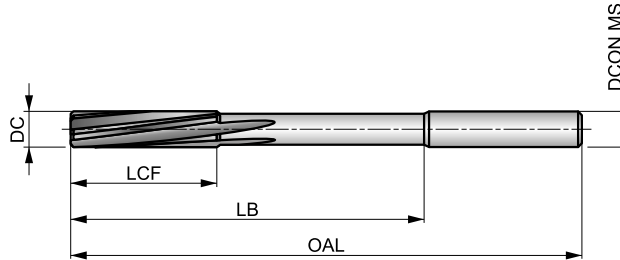

HM	Bright	DIN 8093
R	DIN 6535HA	B
ø 95-5.5 +0.004 ø 5.51-12 +0.005		

Adéquation du groupe de matériaux de la pièce, valeurs de départ pour la vitesse de coupe (m/min) et code Alpha d'avance. Les tableaux d'avances par tour se trouvent à partir de la page 279.

P1.1 ■ 23 B	P1.2 ■ 26 B	P1.3 ■ 27 B	P2.1 ■ 20 B	P2.2 ■ 18 B	P2.3 ■ 16 C	P3.1 ■ 16 B	P3.2 ■ 13 B	P3.3 ■ 11 C	P4.1 ■ 10 B	P4.2 ■ 8 C	P4.3 ■ 7 C	M1.1 ▣ 10 C	M1.2 ▣ 8 C
M2.1 ▣ 9 C	M2.2 ▣ 7 C	M2.3 ▣ 6 B	K1.1 ■ 20 D	K1.2 ■ 15 D	K1.3 ■ 11 D	K2.1 ■ 21 D	K2.2 ■ 17 D	K2.3 ■ 14 D	K3.1 ■ 18 D	K3.2 ■ 14 D	K3.3 ■ 11 D	K5.1 ■ 19 D	K5.2 ■ 15 D
K5.3 ■ 11 D	N1.1 ▣ 60 D	N1.2 ■ 45 D	N1.3 ■ 30 D	N2.1 ■ 38 D	N2.2 ■ 35 D	N2.3 ■ 25 D	N3.1 ■ 64 E	N3.2 ■ 38 E	N3.3 ▣ 19 E	N4.1 ▣ 35 C	N4.2 ▣ 30 C		

DCON MS tolérance h6.

Product	DC	OAL	LCF	LB	NOF	DCON MS
	(mm)	(mm)	(mm)	(mm)		(mm)
B4810.98	0.98	50.0	6.0	22.00	3	3.00
B4810.99	0.99	50.0	6.0	22.00	3	3.00
B4811.03	1.03	50.0	6.0	22.00	3	3.00
B4811.50	1.50	50.0	9.0	22.00	3	3.00
B4811.51	1.51	50.0	10.0	22.00	3	3.00
B4811.52	1.52	50.0	10.0	22.00	3	3.00
B4811.53	1.53	50.0	10.0	22.00	3	3.00
B4811.98	1.98	50.0	12.0	22.00	4	3.00
B4811.99	1.99	50.0	12.0	22.00	4	3.00
B4812.00	2.00	50.0	12.0	22.00	4	3.00
B4812.01	2.01	50.0	12.0	22.00	4	3.00
B4812.02	2.02	50.0	12.0	22.00	4	3.00
B4812.03	2.03	50.0	12.0	22.00	4	3.00
B4812.48	2.48	60.0	16.0	32.00	4	3.00
B4812.49	2.49	60.0	16.0	32.00	4	3.00
B4812.50	2.50	60.0	16.0	32.00	4	3.00
B4812.51	2.51	60.0	16.0	32.00	4	3.00
B4812.52	2.52	60.0	16.0	32.00	4	3.00
B4812.53	2.53	60.0	16.0	32.00	4	3.00
B4812.97	2.97	65.0	17.0	37.00	6	4.00
B4812.98	2.98	65.0	17.0	37.00	6	4.00
B4812.99	2.99	65.0	17.0	37.00	6	4.00
B4813.00	3.00	65.0	17.0	37.00	6	4.00
B4813.01	3.01	65.0	17.0	37.00	6	4.00
B4813.02	3.02	65.0	17.0	37.00	6	4.00
B4813.03	3.03	65.0	17.0	37.00	6	4.00
B4813.97	3.97	75.0	19.0	47.00	6	4.00

Product	DC	OAL	LCF	LB	NOF	DCON MS
	(mm)	(mm)	(mm)	(mm)		(mm)
B4813.98	3.98	75.0	19.0	47.00	6	4.00
B4813.99	3.99	75.0	19.0	47.00	6	4.00
B4814.00	4.00	75.0	19.0	47.00	6	4.00
B4814.01	4.01	75.0	19.0	47.00	6	4.00
B4814.02	4.02	75.0	19.0	47.00	6	4.00
B4814.03	4.03	75.0	19.0	47.00	6	4.00
B4814.97	4.97	93.0	23.0	57.00	6	6.00
B4814.98	4.98	93.0	23.0	57.00	6	6.00
B4814.99	4.99	93.0	23.0	57.00	6	6.00
B4815.00	5.00	93.0	23.0	57.00	6	6.00
B4815.01	5.01	93.0	23.0	57.00	6	6.00
B4815.02	5.02	93.0	23.0	57.00	6	6.00
B4815.03	5.03	93.0	23.0	57.00	6	6.00
B4815.97	5.97	93.0	26.0	57.00	6	6.00
B4815.98	5.98	93.0	26.0	57.00	6	6.00
B4815.99	5.99	93.0	26.0	57.00	6	6.00
B4816.00	6.00	93.0	26.0	57.00	6	6.00
B4816.01	6.01	93.0	26.0	57.00	6	6.00
B4816.02	6.02	93.0	26.0	57.00	6	6.00
B4816.03	6.03	93.0	26.0	57.00	6	6.00
B4817.97	7.97	117.0	33.0	81.00	6	8.00
B4817.98	7.98	117.0	33.0	81.00	6	8.00
B4817.99	7.99	117.0	33.0	81.00	6	8.00
B4818.00	8.00	117.0	33.0	81.00	6	8.00
B4818.01	8.01	117.0	33.0	81.00	6	8.00
B4818.02	8.02	117.0	33.0	81.00	6	8.00
B4818.03	8.03	117.0	33.0	81.00	6	8.00



Product	DC	OAL	LCF	LB	NOF	DCON MS
	(mm)	(mm)	(mm)	(mm)		(mm)
B4818.04	8.04	117.0	33.0	81.00	6	8.00
B4819.97	9.97	133.0	38.0	93.00	6	10.00
B4819.98	9.98	133.0	38.0	93.00	6	10.00
B4819.99	9.99	133.0	38.0	93.00	6	10.00
B48110.00	10.00	133.0	38.0	93.00	6	10.00
B48110.01	10.01	133.0	38.0	93.00	6	10.00
B48110.02	10.02	133.0	38.0	93.00	6	10.00
B48110.03	10.03	133.0	38.0	93.00	6	10.00
B48110.04	10.04	133.0	38.0	93.00	6	10.00

Product	DC	OAL	LCF	LB	NOF	DCON MS
	(mm)	(mm)	(mm)	(mm)		(mm)
B48110.05	10.05	133.0	38.0	93.00	6	10.00
B48111.98	11.98	151.0	44.0	106.00	6	12.00
B48111.99	11.99	151.0	44.0	106.00	6	12.00
B48112.00	12.00	151.0	44.0	106.00	6	12.00
B48112.01	12.01	151.0	44.0	106.00	6	12.00
B48112.02	12.02	151.0	44.0	106.00	6	12.00
B48112.03	12.03	151.0	44.0	106.00	6	12.00
B48112.04	12.04	151.0	44.0	106.00	6	12.00
B48112.05	12.05	151.0	44.0	106.00	6	12.00

B441



Alésoir machine en carbure à queue cylindrique, précision H7, finition brillante

Alésoir avec extrémité en carbure brasée offrant une durée de vie prolongée et des performances supérieures lors de l'alésage de trous dans les limites de la tolérance H7. La conception extrêmement inégale des goujures réduit les vibrations et améliore la cylindricité, l'état de surface et la taille des trous. L'outil offre de grandes performances sur machines CNC.

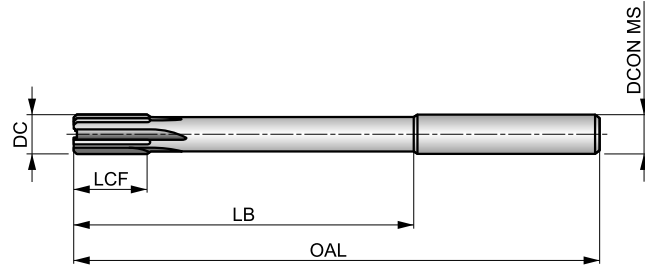

HM	Bright	DIN 8050
R		A
H7		

Adéquation du groupe de matériaux de la pièce, valeurs de départ pour la vitesse de coupe (m/min) et code Alpha d'avance. Les tableaux d'avances par tour se trouvent à partir de la page 279.

P1.1 ■ 23 B	P1.2 ■ 26 B	P1.3 ■ 27 B	P2.1 ■ 20 B	P2.2 ■ 18 B	P2.3 ■ 16 C	P3.1 ■ 16 B	P3.2 ■ 13 B	P3.3 ■ 11 C	P4.1 ■ 10 B	P4.2 ■ 8 C	P4.3 ■ 7 C	M1.1 ▣ 10 C	M1.2 ▣ 8 C
M2.1 ▣ 9 C	M2.2 ▣ 17 C	M2.3 ▣ 16 B	K1.1 ■ 20 D	K1.2 ■ 15 D	K1.3 ■ 11 D	K2.1 ■ 21 D	K2.2 ■ 17 D	K2.3 ■ 14 D	K3.1 ■ 18 D	K3.2 ■ 14 D	K3.3 ■ 11 D	K5.1 ■ 19 D	K5.2 ■ 15 D
K5.3 ■ 11 D	N1.1 ▣ 60 D	N1.2 ■ 45 D	N1.3 ■ 30 D	N2.1 ■ 38 D	N2.2 ■ 35 D	N2.3 ■ 25 D	N3.1 ■ 64 E	N3.2 ■ 38 E	N3.3 ▣ 19 E	N4.1 ▣ 35 C	N4.2 ▣ 30 C		

DCON MS tolerance h9; pointe carbure.

Product	DC (mm)	OAL (mm)	LCF (mm)	LB (mm)	NOF	DCON MS (mm)
B44110.0	10.00	133.0	19.0	87.00	6	10.00
B44111.0	11.00	142.0	19.0	96.00	6	10.00
B44112.0	12.00	151.0	19.0	105.00	6	10.00
B44113.0	13.00	151.0	19.0	105.00	6	10.00
B44114.0	14.00	160.0	19.0	110.00	6	12.50
B44115.0	15.00	162.0	19.0	112.00	6	12.50
B44116.0	16.00	170.0	22.0	120.00	6	12.50
B44117.0	17.00	175.0	22.0	123.00	6	14.00
B44118.0	18.00	182.0	22.0	130.00	6	14.00
B44119.0	19.00	189.0	22.0	131.00	6	16.00
B44120.0	20.00	195.0	22.0	137.00	6	16.00

B411

DORMER



Alésoir machine en carbure à queue cône morse pour précision H7, finition brillante

Alésoir avec extrémité en carbure brasée améliorant considérablement les performances et prolongeant la durée de vie de l'outil lorsque vous alésez des matériaux durs et abrasifs. Les goujures en spirale présentent un espacement inégal entre elles, ce qui réduit efficacement les vibrations et améliore la cylindricité, la taille et la finition des trous.

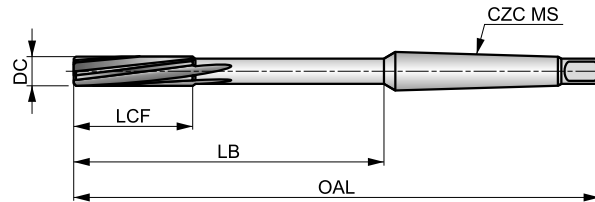

HM	Bright	DIN 8094
R		B
H7		

Adéquation du groupe de matériaux de la pièce, valeurs de départ pour la vitesse de coupe (m/min) et code Alpha d'avance. Les tableaux d'avances par tour se trouvent à partir de la page 279.

P1.1 ■ 23 B	P1.2 ■ 26 B	P1.3 ■ 27 B	P2.1 ■ 20 B	P2.2 ■ 18 B	P2.3 ■ 16 C	P3.1 ■ 16 B	P3.2 ■ 13 B	P3.3 ■ 11 C	P4.1 ■ 10 B	P4.2 ■ 8 C	P4.3 ■ 7 C	M1.1 ▣ 10 C	M1.2 ▣ 8 C
M2.1 ▣ 9 C	M2.2 ▣ 17 C	M2.3 ▣ 16 B	K1.1 ■ 20 D	K1.2 ■ 15 D	K1.3 ■ 11 D	K2.1 ■ 21 D	K2.2 ■ 17 D	K2.3 ■ 14 D	K3.1 ■ 18 D	K3.2 ■ 14 D	K3.3 ■ 11 D	K5.1 ■ 19 D	K5.2 ■ 15 D
K5.3 ■ 11 D	N1.1 ▣ 60 D	N1.2 ■ 45 D	N1.3 ■ 30 D	N2.1 ■ 38 D	N2.2 ■ 35 D	N2.3 ■ 25 D	N3.1 ■ 64 E	N3.2 ■ 38 E	N3.3 ▣ 19 E	N4.1 ▣ 35 C	N4.2 ▣ 30 C		

DC <= 16mm tête carbure; DC > 16mm pointe carbure.

Product	DC (mm)	OAL (mm)	LCF (mm)	LB (mm)	NOF	CZC MS
B4115.0	5.00	133.0	23.0	67.50	6	MK 1
B4116.0	6.00	138.0	26.0	72.50	6	MK 1
B4117.0	7.00	150.0	31.0	84.50	6	MK 1
B4118.0	8.00	156.0	33.0	90.50	6	MK 1
B4119.0	9.00	162.0	36.0	96.50	6	MK 1
B41110.0	10.00	168.0	38.0	102.50	6	MK 1
B41112.0	12.00	182.0	44.0	116.50	6	MK 1
B41114.0	14.00	189.0	47.0	123.50	8	MK 1
B41115.0	15.00	204.0	50.0	124.00	8	MK 2
B41116.0	16.00	210.0	52.0	130.00	8	MK 2
B41117.0	17.00	214.0	54.0	134.00	6	MK 2
B41118.0	18.00	219.0	56.0	139.00	6	MK 2
B41119.0	19.00	223.0	58.0	143.00	6	MK 2
B41120.0	20.00	228.0	60.0	148.00	6	MK 2
B41122.0	22.00	237.0	64.0	157.00	6	MK 2
B41124.0	24.00	268.0	68.0	169.00	8	MK 3
B41125.0	25.00	268.0	68.0	169.00	8	MK 3
B41126.0	26.00	273.0	70.0	174.00	8	MK 3
B41130.0	30.00	281.0	73.0	182.00	8	MK 3

B442



Alésoir machine en carbure à queue conique et pour précision H7, finition brillante

Alésoir conçu avec une denture extrêmement inégale afin de réduire les vibrations et améliorer la taille du trou, la cylindricité et la finition de surface des trous. Le chanfrein à 45° assure un positionnement et un centrage précis pour une qualité de trou et des performances améliorées. La pointe en carbure brasée offre une durée de vie prolongée et des performances supérieures.

HM	Bright	DIN 8051
R		A
H7		

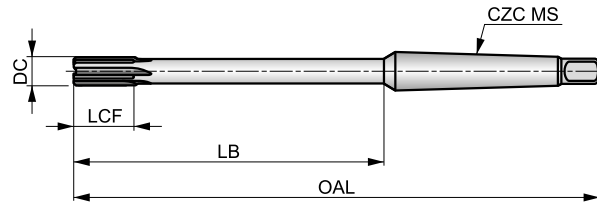

Adéquation du groupe de matériaux de la pièce, valeurs de départ pour la vitesse de coupe (m/min) et code Alpha d'avance. Les tableaux d'avances par tour se trouvent à partir de la page 279.

P1.1 ■ 23 B	P1.2 ■ 26 B	P1.3 ■ 27 B	P2.1 ■ 20 B	P2.2 ■ 18 B	P2.3 ■ 16 C	P3.1 ■ 16 B	P3.2 ■ 13 B	P3.3 ■ 11 C	P4.1 ■ 10 B	P4.2 ■ 8 C	P4.3 ■ 7 C	M1.1 ▣ 10 C	M1.2 ▣ 8 C
M2.1 ▣ 9 C	M2.2 ▣ 7 C	M2.3 ▣ 6 B	K1.1 ■ 20 D	K1.2 ■ 15 D	K1.3 ■ 11 D	K2.1 ■ 21 D	K2.2 ■ 17 D	K2.3 ■ 14 D	K3.1 ■ 18 D	K3.2 ■ 14 D	K3.3 ■ 11 D	K5.1 ■ 19 D	K5.2 ■ 15 D
K5.3 ■ 11 D	N1.1 ▣ 60 D	N1.2 ■ 45 D	N1.3 ■ 30 D	N2.1 ■ 38 D	N2.2 ■ 35 D	N2.3 ■ 25 D	N3.1 ■ 64 E	N3.2 ■ 38 E	N3.3 ▣ 19 E	N4.1 ▣ 35 C	N4.2 ▣ 30 C		

Product	DC (mm)	OAL (mm)	LCF (mm)	LB (mm)	NOF	CZC MS
B44210.0	10.00	168.0	19.0	102.50	6	MK 1
B44212.0	12.00	182.0	19.0	116.50	6	MK 1
B44214.0	14.00	189.0	19.0	123.50	6	MK 1
B44215.0	15.00	204.0	19.0	124.00	6	MK 2
B44216.0	16.00	210.0	22.0	130.00	6	MK 2
B44217.0	17.00	214.0	22.0	134.00	6	MK 2
B44218.0	18.00	219.0	22.0	139.00	6	MK 2
B44219.0	19.00	223.0	22.0	143.00	6	MK 2
B44220.0	20.00	228.0	22.0	148.00	6	MK 2



ISO
13399



PMK
NSH



INSTRUCTIONS

FORETS MONOBLOCS – PAGE DE PRÉSENTATION

1 R003



Foret court en carbure monobloc, avec pointe revêtue TiN

Foret polyvalent d'entrée de gamme avec un angle de pointe de 120°. La géométrie de pointe à quatre facettes réduit la force de poussée et la construction de goujures CTW améliore les taux de pénétration. Le revêtement TiN de la pointe améliore les performances et prolonge la durée de vie de l'outil. Convient aux machines à commande numérique et conventionnelles pour une large gamme de matériaux de pièces à usiner.

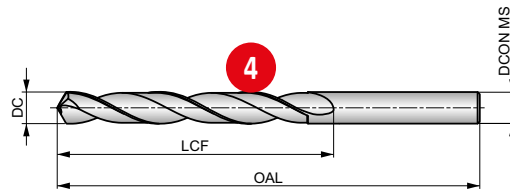

HM	DIN 338	4xD
120°	TiN-Tip	5
λ _{20-35°}	R	DC h7

Adéquation du groupe de matériaux de la pièce, valeurs de départ pour la vitesse de coupe (m/min) et code Alpha d'avance. Les tableaux d'avances par tour se trouvent à partir de la page 274.

P1.1	P1.2	P1.3	P2.1	P2.2	P2.3	P3.1	P3.2	P3.3	P4.1	P4.2	P4.3	K1.1	K1.2
■ 99 S	■ 111 S	■ 115 S	■ 85 S	■ 75 S	■ 66 S	■ 66 S	■ 53 S	■ 45 S	■ 40 S	■ 34 S	■ 27 S	■ 75 T	■ 56 T
K1.3	K2.1	K2.2	K2.3	K3.1	K3.2	K3.3	1.1	K4.2	K4.3	K4.4	K4.5	K5.1	K5.2
■ 42 T	■ 68 T	■ 55 T	■ 44 T	■ 60 T	■ 46 T	■ 37 T	■ 55 T	■ 42 T	■ 31 T	■ 26 T	■ 22 T	■ 63 T	■ 47 T
K5.3	N1.1	N1.2	N1.3	N2.1	N2.2	N2.3	N3.1	N3.2	N4.1	N4.2	H1.1	H2.1	H3.1
■ 37 T	■ 150 V	■ 113 V	■ 75 V	■ 129 V	■ 116 V	■ 84 V	■ 317 V	■ 190 V	■ 60 U	■ 100 U	■ 34 S	■ 20 S	■ 22 S

Product	DC (inch)	DC (mm)	DC (inch)	LCF (mm)	OAL (mm)	DCON MS (mm)
R0031.0	–	1.00	0.0394	12.0	34.0	1.00
R003N60	N60	1.02	0.0400	12.0	34.0	1.02
R0031.1	–	1.10	0.0433	14.0	36.0	1.10
R003N56	N56	1.18	0.0465	16.0	38.0	1.18
R003N54	3/64	1.19	0.0469	16.0	38.0	1.19
R0031.2	–	1.20	0.0472	16.0	38.0	1.20
R0031.3	–	1.30	0.0512	16.0	38.0	1.30
R003N54	N54	1.40	0.0550	18.0	40.0	1.40
R0031.4	–	1.40	0.0551	18.0	40.0	1.40
R0031.5	–	1.50	0.0591	18.0	40.0	1.50
R003N53	N53	1.51	0.0595	20.0	43.0	1.51
R0031/16	1/16	1.59	0.0625	20.0	43.0	1.59
R0031.6	–	1.60	0.0630	20.0	43.0	1.60
R003N52	N52	1.61	0.0635	20.0	43.0	1.61

Product	DC (inch)	DC (mm)	DC (inch)	LCF (mm)	OAL (mm)	DCON MS (mm)
R0032.3	–	2.30	0.0906	27.0	53.0	2.30
R0033/32	3/32	2.38	0.0937	30.0	57.0	2.38
R0032.4	–	2.40	0.0945	30.0	57.0	2.40
R003N41	N41	2.44	0.0960	30.0	57.0	2.44
R0032.5	–	2.50	0.0984	30.0	57.0	2.50
R003N39	N39	2.53	0.0995	30.0	57.0	2.53
R003N38	N38	2.58	0.1015	30.0	57.0	2.58
R0032.6	–	2.60	0.1024	30.0	57.0	2.60
R003N37	N37	2.64	0.1040	30.0	57.0	2.64
R0032.7	–	2.70	0.1063	33.0	61.0	2.70
R003N36	N36	2.71	0.1065	33.0	61.0	2.71
R0037/64	7/64	2.78	0.1094	33.0	61.0	2.78
R0032.8	–	2.80	0.1102	33.0	61.0	2.80
R003N33	N33	2.87	0.1130	33.0	61.0	2.87

Élém.	Description
1	Désignation du foret
2	Descriptif du produit
3	Illustration
4	Schéma de l'outil

Élém.	Description
5	Caractéristiques du produit
6	Recommandations en fonction du groupe de matériaux, notamment indication de la vitesse et de l'avance
7	Code produit
8	Dimensions du produit

PLAQUETTES – PAGE DE PRÉSENTATION

1 SCET



	IC (mm)	D1 (mm)	L (mm)	S (mm)
0502	5.556	3	5.56	2.38
0602	6.350	2.90	6.35	2.38
0703	7.937	3.50	7.94	3.18
09T3	9.525	4.50	9.53	3.97
1204	12.700	5.60	12.70	4.76
1505	15.875	5.60	15.88	5.56

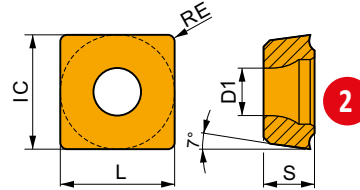

Adéquation et valeurs de départ pour la vitesse de coupe (vc), l'avance (f) et la profondeur de coupe (ap). Reportez-vous à notre application „Calculators“ pour d'autres calculs.

Produit	Intermittent/ Continuous cut (mm)	RE (mm)	P			M			K			N			S			H		
			vc (m/min)	f (mm/rev)	ap (mm)	vc (m/min)	f (mm/rev)	ap (mm)	vc (m/min)	f (mm/rev)	ap (mm)	vc (m/min)	f (mm/rev)	ap (mm)	vc (m/min)	f (mm/rev)	ap (mm)	vc (m/min)	f (mm/rev)	ap (mm)



Géométrie SD avec coupe universelle pour plaquettes périphériques.

SCET 050204-UD-D8330	● 0.4	■ 165	0.08	—	—	—	—	■ 155	0.08	—	—	—	—	—	—	—	—	—	—	—
SCET 050204-UD-D9335	● 0.4	■ 240	0.08	—	—	—	—	■ 225	0.08	—	—	—	—	—	—	—	—	—	—	—
SCET 060204-UD-D8330	● 0.4	■ 165	0.11	—	—	—	—	■ 155	0.11	—	—	—	—	—	—	—	—	—	—	—
SCET 060204-UD-D9335	● 0.4	■ 240	0.11	—	—	—	—	■ 225	0.11	—	—	—	—	—	—	—	—	—	—	—
SCET 070308-UD-D8330	● 0.4	■ 165	0.13	—	—	—	—	■ 155	0.13	—	—	—	—	—	—	—	—	—	—	—
SCET 070308-UD-D9335	● 0.4	■ 240	0.13	—	—	—	—	■ 225	0.13	—	—	—	—	—	—	—	—	—	—	—
SCET 09T308-UD-D8330	● 0.8	■ 165	0.14	—	—	—	—	■ 155	0.14	—	—	—	—	—	—	—	—	—	—	—
SCET 09T308-UD-D9335	● 0.8	■ 240	0.14	—	—	—	—	■ 225	0.14	—	—	—	—	—	—	—	—	—	—	—
SCET 120408-UD-D8330	● 0.8	■ 165	0.16	—	—	—	—	■ 155	0.16	—	—	—	—	—	—	—	—	—	—	—
SCET 120408-UD-D9335	● 0.8	■ 240	0.16	—	—	—	—	■ 225	0.16	—	—	—	—	—	—	—	—	—	—	—
SCET 150512-UD-D8330	● 1.2	■ 165	0.18	—	—	—	—	■ 155	0.18	—	—	—	—	—	—	—	—	—	—	—
SCET 150512-UD-D9335	● 1.2	■ 240	0.18	—	—	—	—	■ 225	0.18	—	—	—	—	—	—	—	—	—	—	—

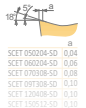

Géométrie SD avec coupe universelle pour plaquettes périphériques.

Élém.	Description
1	Désignation de la plaquette
2	Schéma de la plaquette
3	Tableau des tailles de plaquette (mm)
4	Illustration de la plaquette
5	Profil de l'arête de coupe principale
6	Icônes – caractéristiques spécifiques et type d'arête de coupe

Élém.	Description
7	Code de plaquette ISO: Nuance
8	Conditions de travail
9	Rayons de plaquette (mm)
10	Description de la géométrie
11	Conditions de coupe par groupe de matériaux



FORETS À PLAQUETTES – PAGE DE PRÉSENTATION

Élém.	Description	Élém.	Description
1	Désignation du foret	11	Caractéristiques radiales (mm)
2	Groupe de matériaux recommandés	12	Douille de réglage
3	Système de serrage de la plaquette	13	Groupe de plaquettes compatibles avec brise-copeau UD ^{1),2)}
4	Description de l'outil	14	Groupe de plaquettes compatibles avec brise-copeau SD ^{1),2)}
5	Illustration	15	Poids (kg)
6	Schéma de l'outil	16	Groupe de pièces de rechange ¹⁾
7	Caractéristiques du produit	17	Plaquettes compatibles avec brise-copeau UD
8	Applications du produit	18	Plaquettes compatibles avec brise-copeau SD
9	Code de l'outil	19	Pièces de rechange
10	Dimensions de l'outil		

¹⁾ Le code du groupe de plaquettes et pièces de rechange compatibles est uniquement utile aux fins du présent catalogue. Il ne permet pas de faire des commandes.

²⁾ Les plaquettes externes (SCET) et internes (XPET) doivent toujours avoir le même brise-copeaux. Remarque : le brise-copeaux UD n'apparaît pas dans la désignation des plaquettes XPET (XPET 0502AP, par ex.) ; les informations nécessaires au choix du bon brise-copeau (UD ou SD) se trouvent sur l'emballage de la plaquette.

PRÉSENTATION DES ICÔNES

Îcônes générales

<input type="checkbox"/>	Utilisation principale	<input checked="" type="checkbox"/>	Utilisation possible
--------------------------	------------------------	-------------------------------------	----------------------

Groupe standard de base (BSG)

DIN 1897	DIN 1897 – Forets extra-courts	DIN 6539	DIN 6539	DIN 212	DIN 212 – Alésiors machine
DIN 1899	DIN 1899 – Micro-forets extra-courts	DIN 6537K	DIN 6537 K	DIN 2179	DIN 2179 – Alésiors machine pour goupille conique queue cylindrique
DIN 338	DIN 338 – Forets à queue droite	DIN 6537L	DIN 6537 L	DIN 2180	DIN 2180 – Alésiors machine pour goupille conique queue cône Morse
NAS 907	NAS907 – Forets pour l'aéronautique	DIN 333R	DIN 333R – Forets à centrer, queue droite	DIN 311	DIN 311 – Alésiors de chaudronnerie à queue cône Morse
DIN 340	DIN 340 – Forets longs pointe à 118°	DIN 334C	DIN 334 C – Fraises à ébavurer et à chanfreiner à queue droite	DIN 8050	DIN 8050 – Alésiors machine queue droite
DIN 1869-1	DIN 1869 / 1 – Forets extra-longs à queue droite	DIN 335A	DIN 335 A – Fraises à ébavurer et à chanfreiner à queue droite	DIN 8051	DIN 8051 – Alésiors machine queue cône Morse
DIN 1869-2	DIN 1869 / 2 – Forets extra-longs à queue droite	DIN 335C	DIN 335 C – Fraises à ébavurer et à chanfreiner à queue droite	DIN 8093	DIN 8093 – Alésiors machine queue droite
DIN 1869-3	DIN 1869 / Cône 60-100° – Forets extra-longs à queue droite	DIN 334D	DIN 334 D – Fraises à ébavurer et à chanfreiner à queue cône Morse	DIN 8094	DIN 8094 – Alésiors machine queue cône Morse
DIN 1870(2)	DIN 1870 / 2 – Forets extra-longs à queue cône Morse	DIN 335D	DIN 335 D – Fraises à ébavurer et à chanfreiner à queue cône Morse	DIN 9	DIN Avance (mm/tour) – Alésiors machine pour goupille conique
DIN 345	DIN 345 – Forets courts à queue cône Morse	DIN 373	DIN 373 – Fraises à lamer avec avant-trou	DIN ANSI	Normes DIN/ANSI
DIN 8374	DIN 8374 – Forets étagés 90°	BS 328	BS 328 – Normes pour forets et alésiors	ANSI	ANSI – Norme taraud
DIN 8376	DIN 8376 – Forets étagés 180°	DIN 206	DIN 206 – Alésiors à main	DORMER	Normes Dormer
DIN 333A	DIN 333A – Forets à centrer	DIN 208	DIN 208 – Alésiors machine à queue cône Morse		

Rapport longueur utile diamètre (ULDR)

1xD	1xD Rapport entre la profondeur utile de l'outil et son diamètre	3.5xD	Cône 60-100°.5xD Rapport entre la profondeur utile de l'outil et son diamètre	12xD	12xD Rapport entre la profondeur utile de l'outil et son diamètre
1.25xD	1.25xD Rapport entre la profondeur utile de l'outil et son diamètre	4xD	4xD Rapport entre la profondeur utile de l'outil et son diamètre	15xD	15xD Rapport entre la profondeur utile de l'outil et son diamètre
1.5xD	1.5xD Rapport entre la profondeur utile de l'outil et son diamètre	5xD	5xD Rapport entre la profondeur utile de l'outil et son diamètre	20xD	20xD Rapport entre la profondeur utile de l'outil et son diamètre
2xD	2xD Rapport entre la profondeur utile de l'outil et son diamètre	6xD	6xD Rapport entre la profondeur utile de l'outil et son diamètre	25xD	25xD Rapport entre la profondeur utile de l'outil et son diamètre
2.5xD	2.5xD Rapport entre la profondeur utile de l'outil et son diamètre	8xD	8xD Rapport entre la profondeur utile de l'outil et son diamètre		
3xD	3xD Rapport entre la profondeur utile de l'outil et son diamètre	10xD	10xD Rapport entre la profondeur utile de l'outil et son diamètre		

PRÉSENTATION DES ICÔNES

Angle d'application

118°	Pointe à 118°	120°	Foret à pointer 120°	82°	Cône 82°
120°	Pointe à 120°	150°	Foret à pointer 150°	90°	Cône 90°
122°	Pointe à 122°	90°	Avant-trou avec chanfrein à 90° (pour taraudage)	100°	Cône 100°
130°	Pointe à 130°	90°	Foret étagé (pour fixations), alésage à 90°	60-100°	Cône 60-100°
135°	Pointe à 135°	180°	Foret étagé (pour fixations), alésage à 180°	60°	Foret à centrer, à chanfrein de 60°
140°	Pointe à 140°	180°	Alésage 180°	R	Foret à centrer, profil de type R
90°	Foret à pointer 90°	20°	Foret conique 20°		
90°/120°	Foret à pointer 90°/120°	60°	Cône 60°		

Queue

Queue cylindrique	Queue cylindrique avec extrémité carrée	Queue universelle
Queue cylindrique DIN 6535 HA	Queue cylindrique avec extrémité hexagonale	Queue cylindrique avec collerette
Queue cylindrique avec tenon	Queue cône Morse	ISO 9766 – Queues cylindriques (avec ou sans méplat)
Queue cylindrique avec 3 méplats	Queue cylindrique réduite en diamètre	DIN 6535 – Queue HB (Weldon) ou HE (Whistle)

Forme de spirale

Technologie à âme mince continue (CTW, Continuously Thinned Web)	Goujure hélice rapide	Goujure hélice standard
Goujure hélice rapide	Amincissement spécial de la pointe	

Sens (direction de coupe)

Rotation/coupe à gauche	Rotation/coupe à droite	Arrosage centralisé
-------------------------	-------------------------	---------------------



Propriété d'alimentation en liquide de coupe (CSP)

Classe de tolérance du diamètre de coupe (TCDC)

h6 – Tolérance de perçage norme usine (selon diamètre)	h8 – Tolérance de perçage norme usine (selon diamètre)	
h7 – Tolérance de perçage norme usine (selon diamètre)	m7 – Tolérance de perçage norme usine (selon diamètre)	

PRÉSENTATION DES ICÔNES

Tolérance de trou réalisable (TCHA)

 H7	H7 – Tolérance de trou norme usine (selon diamètre)	 k11	k11 – Tolérance de perçage norme usine (selon diamètre)		Tolérance de trou haute précision (selon diamètre)
---	---	---	---	---	--



















Forme d'alésoir

 A	DIN Forme A – Goujure droitedroite, coupe à droite	 B	DIN Forme B – Goujure avec hélice lente à gauche, coupe à droite
--	--	---	--

Gradient d'inclinaison (taux d'inclinaison)

 1:50	Conicité 2% (1 mm par 50 mm)	 1:48	Conicité (1/Opérations de perçage" par pied)
---	------------------------------	--	--

Opérations de perçage

 Perçage de trous borgnes	 Perçage de matériaux empilés	 Alésage
 Perçage de trous débouchants	 Perçage par interpolation hélicoïdale	 Alésage de trous borgnes
 Perçage sur surface inclinée	 Perçage de soudures	 Alésage de trous débouchants
 Perçage sur surface courbe	 Coupe discontinue	 Alésage par interpolation hélicoïdale
 Perçage débouchant sur surface inclinée	 Chanfreinage (biseautage)	 Alésage sur épaulement
 Perçage dans un trou existant	 Chanfreinage (biseautage) dans un trou	 Alésage sur trous sécants



Caractéristiques de la plaquette

 Pour matériaux tenaces (copeaux longs)	 Gamme d'options universelles
 Usinage lourd	 Arête ronde avec facette

Caractéristiques générales

 1	1 dent par tour	 Conception monobloc	 Compatible usinage excentrique
--	-----------------	---	--

Autres icônes

 Nm	Couple de serrage de la vis (Nm)	 S	S - Serrage par vis à travers le trou	 f	Avance (mm/tour)
---	----------------------------------	---	---------------------------------------	---	------------------

PLAQUETTES – CODIFICATION ISO

ISO	1	2	3	4
	S	C	E	T
ANSI	1	2	3	4
	S	C	E	T

S C E T 05 02 04 - UD

1				2				4			
Forme de la plaquette				Angle de dépouille de la plaquette				Type de plaquette			
H	O	P	R	A		B		N			
				C		D		A			
S	T	C	D	E		F		W		T	
				G		N		Q		U	
E	M	V	W	P		O	Spécial	B		H	
								C		J	
L	A	B	K					X	Spécial		

3				3			
Tolérances							
	(mm)			(")			
	M(±)	S(±)	IC(±)	M(±)	S(±)	IC(±)	
A	0.005	0.025	0.025	.0002"	.001"	.0010"	
F	0.005	0.025	0.013	.0002"	.001"	.0005"	
C	0.013	0.025	0.025	.0005"	.001"	.0010"	
H	0.013	0.025	0.013	.0005"	.001"	.0005"	
E	0.025	0.025	0.025	.0010"	.001"	.0010"	
G	0.025	0.130	0.025	.0010"	.005"	.0010"	
J	0.005	0.025	0.05 – 0.13	.0002"	.001"	.002 – 0.005"	
K	0.013	0.025	0.05 – 0.13	.0005"	.001"	.002 – 0.005"	
L	0.025	0.025	0.05 – 0.13	.0010"	.001"	.002 – 0.005"	
M	0.08 – 0.18	0.130	0.05 – 0.13	.003 – 0.007"	.005"	.002 – 0.005"	
N	0.08 – 0.18	0.025	0.05 – 0.13	.003 – 0.007"	.001"	.002 – 0.005"	
U	0.05 – 0.38	0.130	0.05 – 0.13	.005 – 0.015"	.005"	.003 – 0.010"	

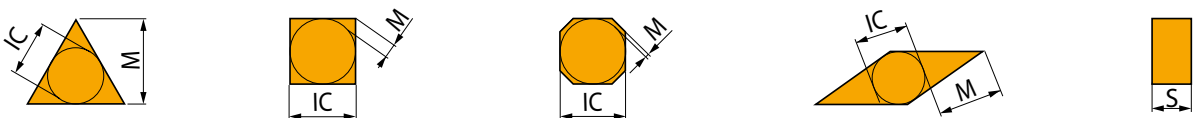

PLAQUETTES – CODIFICATION ISO

5	6	7	8	9	10
05	02	04			UD
5	6	7	8	9	10
1.8	1.5	1			UD

		5												
		Longueur de l'arête de coupe (taille de plaquette)												
d=IC		H	O	P	S	T	C	D	E	M	V	W	R	K
(mm)	(in)													
3.97					03	06		04			06	02		
4.76	5/32"				04	08	04	05	04	04	08	L3		
5.56	3/16"				05	09	05	06	05	05	09	03		
6.35	7/32"				05	09	05	06	05	05	09	03		
7.94	1/4"	03	02	04	08	11	06	07	08	08	11	04	06	
9.525	5/16"	04	03	05	07	13	08	09	06	07	13	05	07	
12.7	3/8"	05	04	07	09	16	09	11	09	09	16	06	09	16
15.875	1/2"	07	05	09	12	22	12	15	13	12	22	08	12	
19.05	5/8"	09	06	11	15	27	16	19	16	15	27	10	15	
25.40	3/4"	11	07	13	19	33	19	23	19	19	33	13	19	
31.75	1"	14	10	18	25	44	25	31	26	25	44	17	25	
	1 1/4"	18	13	23	31	54	32	38	32	31	54	21	31	

		6	
		Épaisseur de la plaquette	
		S	
		(mm)	(")
01		1.59	1/16"
T1		1.98	5/64"
02		2.38	3/32"
03		3.18	1/8"
T3		3.97	5.32"
04		4.76	3/16"
05		5.56	7/32"
06		6.35	1/4"
07		7.94	5/16"
09		9.52	3/8"

		7	
		Rayon de pointe de la plaquette	
		RE	
		(mm)	(")
00		0	0"
02		0.2	1/128"
04		0.4	1/64"
08		0.8	1/32"
12		1.2	3/64"
16		1.6	1/16"
24		2.4	3/32"
32		3.2	1/8"
Plaquettes rondes			
		d=I.C.	
		(")	00
		(mm)	M0

ANSI					
5		6		7	
Cercle inscrit		Épaisseur de la plaquette		Rayon de pointe de la plaquette	
Symbol	d=I.C.	Symbol	S	Symbol	RE
	(mm) (")		(mm) (")		(mm) (")
1	3.175 1/8"	1	1.588 1/16"	0	0 0"
1.2	3.969 5/32"	1.2	1.984 5/64"	0.2	0.099 1/256"
1.5	4.763 3/16"	1.5	2.381 3/32"	0.5	0.198 1/128"
1.8	5.556 7/32"	2	3.175 1/8"	1	0.397 1/64"
2	6.350 1/4"	2.5	3.969 5/32"	2	0.794 1/32"
2.5	7.938 5/16"	3	4.763 3/16"	3	1.191 3/64"
3	9.525 3/8"	3.5	5.556 7/32"	4	1.588 1/16"
4	12.700 1/2"	4	6.350 1/4"	5	1.984 5/64"
5	15.875 5/8"	5	7.938 5/16"	6	2.381 3/32"
6	19.050 3/4"	6	9.525 3/8"	7	2.778 7/64"
7	22.225 7/8"	7	11.113 7/16"	8	3.175 1/8"
8	25.400 1"	8	12.700 1/2"	10	3.969 5/32"
10	31.750 5/4"	9	14.288 9/16"	12	4.763 3/16"
12	38.100 6/4"	10	15.875 5/8"	14	5.556 7/32"
				16	6.350 1/4"

8		8	
Configuration de l'arête de coupe			
	Arêtes vives		Arêtes arrondies
	Arêtes avec listel		Arêtes arrondies avec listel
	Arêtes avec double listel		Arêtes arrondies avec double listel

9		9	
Direction d'avance			
R		N	
L			

10		10	
Désignation du brise-copeaux (géométrie)			

CODIFICATION DES FORETS

1	2	3	4	5	6	7
8	05	D	19	95	S	25



1		2		3		4	
Type d'outil		Longueur approximative		Version		Diamètre de coupe	
8	Foret à plaquettes indexables	02	2 × DC	D	Foret	15.5	DC = 15.5 mm
		03	3 × DC				
		04	4 × DC			19	DC = 19 mm
		05	5 × DC				

5		6		7	
Profondeur de perçage max.		Type de queue		Diamètre de queue	
35	35 mm	E	Whistle Notch	25	DCON MS = 25 mm
95	95 mm			32	DCON MS = 32 mm
140	140 mm	S	ISO 9766	40	DCON MS = 40 mm

PARAMÈTRES DES OUTILS DE COUPE SELON ISO 13399

Tous les outils de coupe sont définis par un certain nombre de paramètres selon la norme ISO 13399. Cette liste contient tous les paramètres utilisés dans ce catalogue et leurs définitions.

ISO 13399 est une norme internationale d'information sur les outils de coupe. Elle fournit des dimensions et des paramètres dans un format neutre, indépendant de tout système ou nomenclature d'entreprise. Lorsque les outils de coupe sont clairement définis selon une norme globale, tous les types de logiciels peuvent traiter les données électroniques plus rapidement, améliorant la qualité de la communication et contribuant au bon déroulement des échanges d'informations. En

prenant en charge un langage commun dans nos descriptions d'outils de coupe, ce système aidera à la communication du système. Cela vous fera gagner un temps considérable, en facilitant la collecte de données de haute qualité à travers nos 40 000 outils monoblocs et indexables. En utilisant un système conforme ISO 13399, il ne sera pas nécessaire d'interpréter manuellement les données et de les saisir au clavier dans votre système.

Exemples

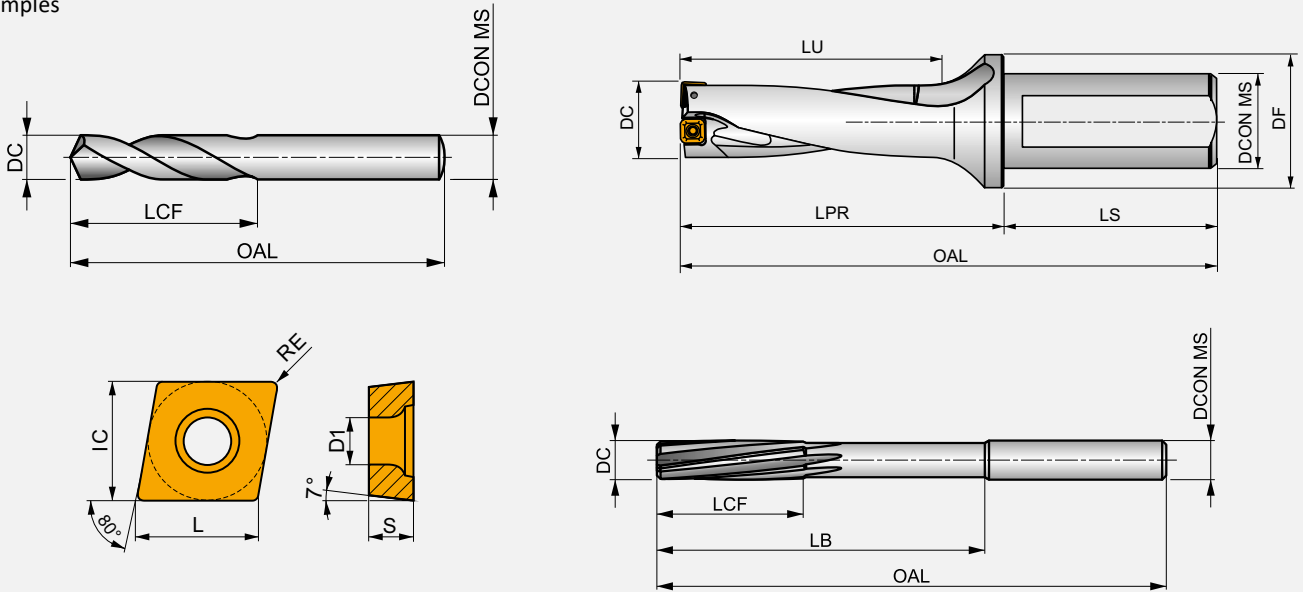





ISO 13399	description
BD	Diamètre du corps
BDX	Diamètre maximum du corps
CZC MS	Code de taille du raccord côté machine
D1	Diamètre du trou de fixation
DC	Diamètre de coupe
DCN	Diamètre de coupe minimum
DCON MS	Diamètre de raccordement côté machine
DCON WS	Diamètre de raccordement côté pièce usinée
DCX	Diamètre de coupe maximum
DHUB	Diamètre de moyeu
FLGT	Épaisseur de bride
IC	Diamètre du cercle inscrit
L	Longueur de l'arête de coupe
LB	Longueur de corps
LF	Longueur fonctionnelle
LPR	Longueur en saillie
LU	Longueur utile
OAL	Longueur totale
RE	Rayon d'angle
S	Épaisseur de plaquette
WF	Largeur fonctionnelle
APMX	Profondeur de coupe maximum
D1	Diamètre du trou de fixation
DC_1	Diamètre de coupe, premier étage
DC_2	Diamètre de coupe, deuxième étage







ISO 13399	description
DF	Diamètre de colerette
DH	Diamètre de la tête
GPD	Diamètre du pilote
GPL	Longueur du pilote
H	Hauteur de queue/de manche
HSD	Taille de l'empreinte
IC	Diamètre du cercle inscrit
LCF	Longueur des goujures
LCOL	Longueur de la pince
LDC	Distance au point de référence PK
LH	Longueur de la tête
LS	Longueur de queue
LSC	Longueur de serrage
NOF	Nombre de goujures
PLGL	Longueur de pointe
RCSK	Rayon de la pointe à centrer
RE	Rayon d'angle
SDI	Incréments, diamètre étagé
SDL	Longueur diamètre étagé
SDL_1	Longueur diamètre étagé 1
SDL_2	Longueur diamètre étagé 2
TDZ	Taille de diamètre du filet
THLGTH	Longueur du filet
WSC	Largeur de serrage

RECHERCHE PAR MATÉRIAU D'OUTIL





Matériaux

Acier rapide		Un acier rapide moyennement allié qui présente une bonne usinabilité et de bonnes performances. L'acier rapide présente des caractéristiques de dureté, de ténacité et de résistance à l'usure qui en font un bon choix pour une large gamme d'applications, notamment pour les forets et les tarauds.
Acier rapide au cobalt		Cet acier rapide contient du cobalt pour une dureté à chaud accrue. La composition du HSCo apporte une bonne combinaison de ténacité et de dureté. Il présente une bonne usinabilité et une bonne résistance à l'usure. Il convient donc à la production de forets, de tarauds, de fraises et d'alésoirs.
Carbure et Acier rapide		Le carbure et l'acier rapide sont généralement combinés grâce à un alliage de brasage à haute température qui sert d'interface. La partie coupante en carbure monobloc assure une haute résistance à la compression, une dureté et une résistance à l'usure élevée, et le corps en acier rapide apporte une bonne résistance à la flexion et ténacité.
Carbures (ou matériaux durs)		Substrat fritté de la métallurgie des poudres, constitué d'un composite de carbure métallique avec un métal liant. La matière première essentielle est le carbure de tungstène (WC). C'est lui qui confère sa dureté au matériau. Le carbure de tantale (TaC), le carbure de titane (TiC) et le carbure de niobium (NbC) viennent compléter le WC pour obtenir les propriétés spécifiques recherchées. Ces trois matériaux sont appelés des « carbures cubiques ». Le cobalt (Co) sert de liant et assure donc l'homogénéité du matériau final. Les matériaux au carbure se caractérisent généralement par une haute résistance à la compression, une dureté élevée et donc une grande résistance à l'usure, mais aussi une résistance à la flexion et une ténacité limitées. Le carbure est utilisé dans la fabrication de tarauds, d'alésoirs, de fraises, de forets et de fraises à fileter.

Traitements superficiels

Brillant (non revêtu)		La finition brillante (surface non revêtue) facilite le glissement des copeaux dans les matériaux non-ferreux ou doux, les plastiques et les matériaux composites, tout en préservant le tranchant des arêtes de coupe.
Nickelage brillant		Le nickelage brillant protège le corps en acier trempé de la rouille, de la corrosion et améliore l'évacuation des copeaux.
Combinaison brillant et traitement vapeur		La combinaison de la finition brillante et du traitement vapeur apporte des avantages concrets : la surface plus poreuse de l'oxyde bleu attire et retient le fluide de coupe dans le trou tandis que la surface brillante facilite l'évacuation des copeaux. Cette combinaison s'obtient par meulage de la surface brillante après traitement vapeur.
Traitement vapeur		Le traitement vapeur apporte une finition de surface bleue particulièrement adhérente pour retenir le fluide de coupe et éviter que les copeaux ne se collent à l'outil. Il contribue donc à lutter contre la formation d'arêtes rapportées. Le traitement vapeur peut être appliqué sur n'importe quel outil brillant, mais il apporte de meilleurs résultats sur les forets et les tarauds.
Finition bronze		La finition bronze est créée par une couche fine et régulière d'oxyde de bronze sur toute la surface de l'outil. Similaire au traitement vapeur, elle évite que les copeaux ne se collent à l'outil et facilite l'évacuation des copeaux. Cette finition peut être appliquée à tous les outils brillants et peut être combinée avec le traitement vapeur (pour certains outils).
Oxyde de bronze et traitement vapeur		La combinaison de l'oxyde de bronze et du traitement vapeur apporte des avantages concrets : la surface plus poreuse de l'oxyde bleu attire et retient le fluide de coupe dans le trou tandis que la surface couleur bronze facilite l'évacuation des copeaux. Ces deux traitements de surface protègent efficacement l'outil. Pour réaliser cette combinaison, deux cycles de trempé sont nécessaires.

Revêtements de surface

Brillant et TiN (revêtement de pointe) Nitre de titane (TiN)		Le nitride de titane est un revêtement céramique de couleur or appliqué par dépôt physique en phase vapeur (PVD). Une dureté élevée, associée à un faible frottement, permet d'augmenter la durée de vie des outils ou d'améliorer les performances de coupe par rapport à des outils non revêtus.
Nitride de titane aluminium (TiAlN, TiAlN-Top et X-CEED)		Le nitride de titane aluminium est un revêtement céramique multi-couche appliqué par procédé PVD. Il confère une ténacité et une stabilité à l'oxydation élevées. Ces propriétés en font un matériau idéal pour des vitesses et avances plus élevées, tout en améliorant la durée de vie des outils. Le TiAlN est utilisé dans le perçage, le taraudage et le fraisage. Il peut également convenir aux usinages sans refroidissement. Le revêtement TiAlN-Top est identique au TiAlN, mais il subit un traitement après revêtement pour lisser les imperfections, améliorer le flux de copeaux et réduire la formation d'arêtes rapportées.
Ti-phon (TiAlCrSiN)		Le revêtement Ti-phon est similaire au TiAlN, mais il comporte en plus du chrome (Cr) et du silicium (Si). Il est spécialement formulé pour les têtes Hydra afin d'éviter la formation d'arête rapportée et d'améliorer considérablement le flux de copeaux. Ce revêtement présente une dureté à chaud élevée, une grande résistance à l'oxydation et un pouvoir lubrifiant supérieur lorsqu'il est utilisé sur des outils destinés à des usinages sous fortes contraintes mécaniques et thermiques, des vitesses et des avances élevées. Les propriétés de ce revêtement se traduisent par une résistance supérieure à l'usure et une plus grande robustesse des arêtes.
Carbonitride de titane aluminium (AlTiCN)		Le carbonitride de titane aluminium (AlTiCN) est un revêtement PVD qui a été spécialement conçu pour répondre aux exigences rigoureuses de l'industrie médicale. Cependant, il convient très bien à certaines opérations des outils de coupe grâce à sa technologie de film mince de haute qualité, et ses excellentes caractéristiques de microdureté et d'adhérence.

NUANCES POUR LE PERÇAGE

Identification de la nuance	Domaine d'application	Application	Avance	Vitesse de coupe	Résistance en conditions de travail compliquées	Revêtement	Couleur	Substrat	Bénéfice arrosage	Description de la nuance
D9335	P20 - P35	■				MT-CVD	FGM	FGM	+++	Cette nuance est recommandée pour les plaquettes périphériques des forets indexables ; elle convient parfaitement aux vitesses de coupe et aux avances les plus élevées.
	M15 - M30	■								
	K15 - K35	■								
	S10 - S20	■								
D8330	P20 - P35	■				PVD	submicron H	submicron H	+++	Il s'agit d'une nuance universelle pour les plaquettes périphériques des forets indexables ; elle peut être utilisée sur la plupart des matériaux et se distingue par sa grande fiabilité opérationnelle.
	M15 - M30	■								
	K15 - K35	■								
	S10 - S20	■								
D8345	P30 - P50	■				PVD	submicron H	submicron H	+++	Cette nuance est une nuance universelle pour la plaquette centrale des forets indexables ; elle est extrêmement résistante et convient à la plupart des matériaux.
	M20 - M40	■								
	K30 - K40	■								
	S20 - S30	■								

Substrat

submicron H	Substrat à grains fins base WC-Co (< 1 µm)
FGM	Substrat gradient fonctionnel

Revêtement

MT-CVD	Méthode de revêtement par dépôt chimique à moyenne température
PVD	Méthode de revêtement par dépôt physique à basse température

Bénéfices de l'arrosage

+++	L'utilisation de l'arrosage est essentielle
-----	---



FORETS MONOBLOCS – INFORMATIONS TECHNIQUES

Nomenclature

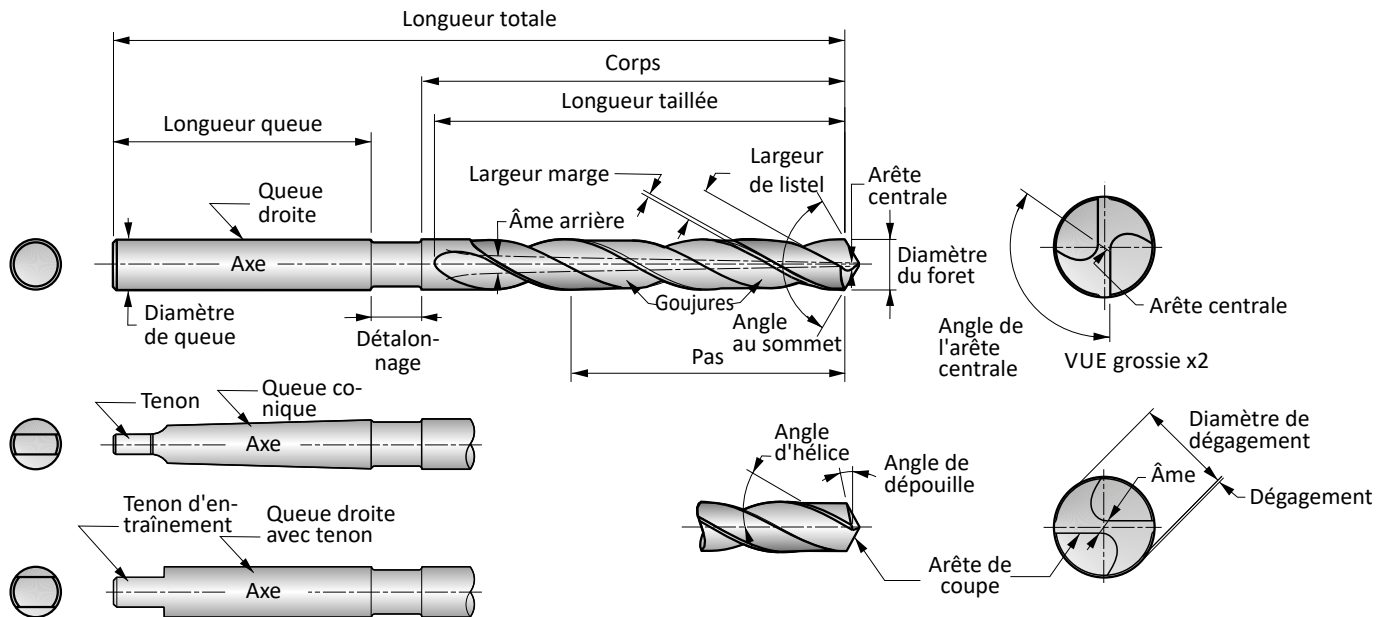

- **Axe** : ligne droite imaginaire qui forme l'axe longitudinal d'un foret.
- **Conicité arrière** : légère réduction de diamètre longitudinal vers la queue d'un foret.
- **Corps** : partie du foret qui s'étend de la queue ou du détalonnage jusqu'à l'extrémité des arêtes de coupe.
- **Dégagement** : partie du listel qui a été réduite pour offrir une dépouille et éviter le contact avec les parois du trou.
- **Arête centrale** : intersection des arêtes de coupe à l'extrémité de l'âme.
- **Angle de l'arête centrale** : angle obtus entre l'arête centrale et l'arête de coupe, vu de l'extrémité du foret.
- **Diamètre de dégagement** : diamètre de dégagement (partie retirée) derrière les listels.
- **Foret** : outil de coupe rotatif ayant une ou plusieurs arêtes de coupe et une ou plusieurs goujures hélicoïdales ou droites pour l'évacuation des copeaux et le passage d'un fluide de coupe.
- **Diamètre du foret** : diamètre d'un foret mesuré à son extrémité.
- **Longueur taillée** : distance entre les angles externes des arêtes de coupe et l'extrémité des goujures côté queue. Cette distance s'étend jusqu'à la naissance des goujures et ne correspond donc pas à la longueur utile de ces dernières.
- **Goujures** : rainures hélicoïdales ou droites taillées dans le corps d'un foret pour former des arêtes de coupe, permettre l'évacuation des copeaux et laisser le fluide de coupe atteindre le tranchant.
- **Angle d'hélice** : angle formé entre la tangente en un point au bord d'attaque du listel et un plan contenant l'axe d'un foret.
- **Listel** : partie périphérique du corps entre les goujures adjacentes.
- **Largeur de listel** : distance entre le bord d'attaque et le talon du listel, mesurée à angle droit par rapport au bord d'attaque.
- **Pas** : avance axiale d'un bord d'attaque du listel en un tour complet de ce dernier.
- **Angle de dépouille** : angle de dépouille axial à l'angle externe de l'arête, mesuré par projection sur un plan tangent à la périphérie à l'angle externe de l'arête.
- **Arêtes** : arêtes de coupe d'un foret à deux goujures s'étendant du bord de l'arête centrale à la périphérie.
- **Marge** : partie cylindrique du listel, qui n'a pas été retirée, pour offrir un dégagement.
- **Détalonnage** : section cylindrique de diamètre réduit entre le corps et la queue d'un foret.
- **Longueur totale** : distance entre l'extrémité de la queue et les angles externes des arêtes de coupe. Cette distance n'inclut pas la queue conique souvent présente sur les forets de ce type, ni l'extrémité de coupe conique présente sur les forets à queue droite comme à queue conique.
- **Pointe** : extrémité coupante d'un foret formée par les extrémités des listels et de l'âme. La pointe semble conique, visuellement, mais elle ne l'est pas vraiment pour offrir un dégagement entre les arêtes de coupe.
- **Pointe conventionnelle** : les pointes conventionnelles présentent un angle de 118° et sont les plus couramment utilisées car elles donnent des résultats satisfaisants dans une grande variété de matériaux. Une limite à cette polyvalence est toutefois l'arête centrale droite qui contribue à une certaine déviation au point de perçage, ce qui rend souvent nécessaire de repérer le trou pour améliorer la précision.

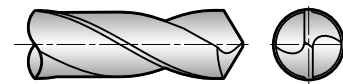

- **Pointe en croix** : les forets à pointe en croix (communément appelées « forets de vilebrequin ») ont été initialement développés pour percer des trous d'huile profonds dans les vilebrequins automobiles. Depuis, cette conception a été largement adoptée pour de nombreux types de forets, à 118° et 135° , y compris les forets à angles au sommet. Ses principaux avantages sont la réduction des contraintes de poussée et l'élimination de toute déviation au point de perçage. Ce dernier avantage est particulièrement intéressant en perçage manuel ou lorsqu'il est impossible d'utiliser

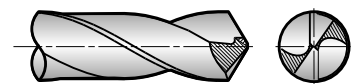



FORETS MONOBLOCS – INFORMATIONS TECHNIQUES

- **Pointe fendue** : les forets à pointe fendue ont été développés pour le perçage d'alliages tenaces. Les forets à âme épaisse incluent souvent une pointe fendue pour que celle-ci résiste aux contraintes de poussée plus élevées, imposées lors du perçage de ce type de matériaux. Comme pour la pointe en croix, la pointe fendue possède deux arêtes de coupe positives s'étendant jusqu'au centre du foret. Ces arêtes de coupe secondaires, qui ne dépassent pas la moitié de l'arête de coupe principale, peuvent aider à contrôler l'évacuation des copeaux et à réduire le couple nécessaire au perçage des matériaux tenaces. Les pointes fendues peuvent être intégrées à des forets de 118° et 135°, faisant d'eux des outils très polyvalents.

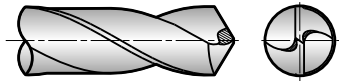

- **Angle au sommet** : angle formé entre les arêtes de coupe projetées sur un plan parallèle à l'axe du foret et aux deux arêtes.
- **Hauteur d'arête relative** : différence de relevé entre les arêtes de coupe d'un foret, mesurée à angle droit par rapport à l'arête et à une distance donnée par rapport à l'axe de l'outil.
- **Queue** : partie du foret utilisée pour la prise et l'entraînement.
- **Tenon** : extrémité plate d'une queue conique destinée à s'insérer dans la fente d'une douille.
- **Tenon d'entraînement** : deux découpes plates d'entraînement parallèles et opposées à l'extrémité d'une queue droite.
- **Queue conique** : les forets à queue conique conviennent au montage direct dans les broches de machines, les manchons d'entraînement ou les douilles. Les queues coniques sont généralement dotées d'un tenon.
- **Âme** : partie centrale du corps d'un foret où se rejoignent les listels. L'extrémité de l'âme forme l'arête centrale d'un foret à deux goujures.
- **Épaisseur de l'âme** : épaisseur de l'âme mesurée à l'extrémité du foret, sauf mention contraire.

Recommandations générales pour le perçage

1. Sélectionner le foret le mieux adapté à l'application, en tenant compte du matériau à usiner, de la capacité de la machine-outil et du fluide de coupe utilisé.
2. La flexibilité entre la pièce et l'axe de la machine peut abîmer le foret aussi bien que la pièce et la machine. Il faut donc assurer un maximum de stabilité à toutes les étapes. Vous pouvez limiter ce problème en choisissant le foret le plus court possible pour l'application.
3. Le mandrin est un aspect important dans l'opération de perçage et le foret ne peut se permettre de casser ou de bouger du porte-outil.
4. Pour bien utiliser des forets à queue cône Morse, un ajustement précis entre les surfaces coniques de l'outil et le porte-outil est in-

dispensable. Il est recommandé d'utiliser un maillet en caoutchouc pour enfoncer le foret dans le porte-outil.

5. Il est recommandé d'utiliser les fluides et les lubrifiants requis pour l'opération de perçage en question. Lors de l'utilisation de fluides de coupe ou de lubrifiants, il faut assurer un arrosage copieux, et plus particulièrement à la pointe du foret.
6. L'évacuation des copeaux durant le perçage est essentielle pour assurer une bonne opération de perçage. Ne jamais permettre aux copeaux de rester dans la goujure.
7. Lors du réaffûtage d'un foret, toujours veiller à ce que la géométrie de la pointe soit respectée et que toute trace d'usure ait été éliminée.

TABLEAU DES AVANCES POUR LES FORETS MONOBLOCS

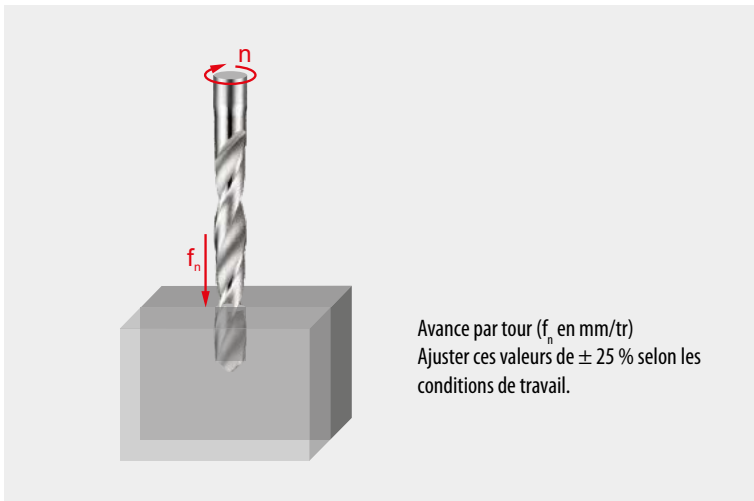

- Comment trouver l'avance par tour (f_n) grâce à ce tableau :**
1. Rechercher le code Alpha sur la page produit (par ex. 46J, « J » étant le code Alpha).
 2. Trouver le diamètre le plus proche de celui recherché pour votre application (première ligne du tableau).
 3. Rechercher votre code Alpha dans la colonne gauche du tableau.
 4. La cellule à l'intersection de la colonne Diamètre et de la ligne code Alpha indique l'avance par tour (f_n).

		\varnothing DC (mm)																		
		0.15	0.50	1.00	2.00	3.00	4.00	5.00	6.00	8.00	10.00	12.00	15.00	16.00	20.00	25.00	30.00	40.00	50.00	100.00
Avances (mm/tr)	A	0.003	0.006	0.012	0.023	0.029	0.032	0.036	0.042	0.054	0.062	0.069	0.082	0.086	0.110	0.125	0.135	0.155	0.175	0.263
	B	0.004	0.007	0.014	0.028	0.037	0.041	0.046	0.053	0.067	0.080	0.090	0.103	0.108	0.135	0.153	0.165	0.188	0.208	0.312
	C	0.004	0.008	0.015	0.032	0.044	0.050	0.056	0.064	0.080	0.098	0.110	0.125	0.130	0.160	0.180	0.195	0.220	0.240	0.360
	D	0.004	0.008	0.016	0.038	0.053	0.060	0.068	0.078	0.098	0.119	0.130	0.149	0.155	0.188	0.210	0.228	0.253	0.275	0.413
	E	0.004	0.009	0.017	0.043	0.062	0.071	0.080	0.092	0.115	0.140	0.150	0.173	0.180	0.215	0.240	0.260	0.285	0.310	0.465
	F	0.005	0.009	0.018	0.050	0.073	0.084	0.095	0.109	0.138	0.165	0.178	0.202	0.210	0.248	0.275	0.295	0.320	0.343	0.515
	G	0.005	0.010	0.019	0.056	0.084	0.096	0.109	0.126	0.160	0.190	0.205	0.231	0.240	0.280	0.310	0.330	0.355	0.375	0.563
	H	0.005	0.010	0.020	0.066	0.102	0.116	0.130	0.150	0.190	0.228	0.243	0.271	0.280	0.320	0.355	0.375	0.398	0.418	0.627
	I	0.005	0.011	0.021	0.076	0.119	0.134	0.150	0.173	0.220	0.265	0.280	0.310	0.320	0.360	0.400	0.420	0.440	0.460	0.690
	J	0.006	0.012	0.024	0.084	0.135	0.152	0.170	0.197	0.250	0.298	0.315	0.349	0.360	0.405	0.445	0.465	0.485	0.503	0.755
	K	0.007	0.013	0.026	0.092	0.150	0.170	0.190	0.220	0.280	0.330	0.350	0.388	0.400	0.450	0.490	0.510	0.530	0.545	0.818
	L	0.007	0.014	0.028	0.101	0.165	0.186	0.208	0.240	0.305	0.360	0.385	0.419	0.430	0.485	0.525	0.545	0.568	0.588	0.882
	M	0.008	0.015	0.030	0.110	0.180	0.202	0.225	0.260	0.330	0.390	0.420	0.450	0.460	0.520	0.560	0.580	0.605	0.630	0.945
	N	0.008	0.016	0.032	0.119	0.195	0.218	0.242	0.280	0.355	0.420	0.455	0.481	0.490	0.555	0.595	0.615	0.642	0.672	1.008
	S	0.002	0.004	0.008	0.014	0.020	0.025	0.030	0.037	0.050	0.080	0.100	0.123	0.130	0.150	0.170	0.190	0.220	0.240	–
	T	0.004	0.008	0.015	0.028	0.040	0.050	0.060	0.070	0.090	0.110	0.130	0.160	0.170	0.190	0.210	0.230	0.260	0.275	–
	U	0.007	0.013	0.026	0.048	0.070	0.080	0.090	0.107	0.140	0.170	0.200	0.223	0.230	0.240	0.270	0.300	0.360	0.375	–
	V	0.010	0.019	0.038	0.069	0.100	0.115	0.130	0.153	0.200	0.250	0.280	0.310	0.320	0.340	0.400	0.440	0.510	0.530	–
	W	0.012	0.025	0.049	0.089	0.130	0.150	0.170	0.200	0.260	0.330	0.380	0.418	0.430	0.450	0.470	0.490	0.520	0.540	–
	X	0.014	0.028	0.056	0.103	0.150	0.180	0.210	0.250	0.330	0.420	0.480	0.533	0.550	0.580	–	–	–	–	–
	Y	0.017	0.034	0.068	0.124	0.180	0.220	0.260	0.317	0.430	0.550	0.700	0.700	0.700	0.740	–	–	–	–	–
Z	0.024	0.047	0.094	0.172	0.250	0.325	0.400	0.533	0.800	1.000	1.100	1.175	1.200	1.200	–	–	–	–	–	

Formules (mm)	Termes	Formules (pouces)
$v_c = \frac{n \times DC \times \pi}{1000}$	v_c (m/min)	$SFM = \frac{RPM \times DC \times \pi}{12}$
$n = \frac{v_c \times 1000}{DC \times \pi}$	n (tr/min)	$RPM = \frac{SFM \times 12}{DC \times \pi}$
$V_f = f_z \times z \times n$	V_f (mm/min)	$IPM = IPT \times T \times RPM$
$f_z = \frac{V_f}{z \times n}$	f_z (mm/dent)	$IPT = \frac{IPM}{T \times RPM}$
$Q = \frac{V_f \times a_p \times a_e}{1000}$	DC (mm)	$MRR = IPM \times DOC \times WOC$
	z (–)	
	a_p (mm)	
	a_e (mm)	
	Q (cm ³ /min)	
	Vitesse de coupe	SFM (pied/min)
	Vitesse de rotation de l'axe	RPM (tr/min)
	Avance	IPM (pouce/min)
	Avance par dent	IPT (pouce/dent)
	Diamètre de coupe	DC (po)
	Nombre de dents	T (–)
	Profondeur de coupe	DOC (po)
	Largeur de coupe	WOC (po)
	Taux d'enlèvement de métal	MRR (po ³ /min)

INFORMATIONS TECHNIQUES GÉNÉRALES

Tableau des vitesses de coupe

		Vc															
m/min.		5	8	10	15	20	25	30	40	50	60	70	80	90	100	110	150
SFM (pieds/min.)		16	26	32	50	66	82	98	130	165	197	230	262	296	330	362	495
Ø																	
		Tr/min															
mm	po																
1.00	–	1592	2546	3183	4775	6366	7958	9549	12732	15916	19099	22282	25465	28648	31831	35014	47747
1.50	–	1061	1698	2122	3183	4244	5305	6366	8488	10610	12732	14854	16977	19099	21221	23343	31831
2.00	–	796	1273	1592	2387	3183	3979	4775	6366	7958	9549	11141	12732	14324	15916	17507	23873
2.50	–	637	1019	1273	1910	2546	3183	3820	5093	6366	7639	8913	10186	11459	12732	14006	19099
3.00	–	531	849	1061	1592	2122	2653	3183	4244	5305	6366	7427	8488	9549	10610	11671	15916
3.18	1/8	500	801	1001	1501	2002	2502	3003	4004	5005	6006	7007	8008	9009	10010	11011	15015
3.50	–	455	728	909	1364	1819	2274	2728	3638	4547	5457	6366	7276	8185	9095	10004	13642
4.00	–	398	637	796	1194	1592	1989	2387	3183	3979	4775	5570	6366	7162	7958	8754	11937
4.50	–	354	566	707	1061	1415	1768	2122	2829	3537	4244	4951	5659	6366	7074	7781	10610
4.76	3/16	334	535	669	1003	1337	1672	2006	2675	3344	4012	4681	5350	6018	6687	7356	10031
5.00	–	318	509	637	955	1273	1592	1910	2546	3183	3820	4456	5093	5730	6366	7003	9549
6.00	–	265	424	531	796	1061	1326	1592	2122	2653	3183	3714	4244	4775	5305	5836	7958
6.35	1/4	251	401	501	752	1003	1253	1504	2005	2506	3008	3509	4010	4511	5013	5514	7519
7.00	–	227	364	455	682	909	1137	1364	1819	2274	2728	3183	3638	4093	4547	5002	6821
7.94	5/16	200	321	401	601	802	1002	1203	1604	2004	2405	2806	3207	3608	4009	4410	6013
8.00	–	199	318	398	597	796	995	1194	1592	1989	2387	2785	3183	3581	3979	4377	5968
9.00	–	177	283	354	531	707	884	1061	1415	1768	2122	2476	2829	3183	3537	3890	5305
9.53	3/8	167	267	334	501	668	835	1002	1336	1670	2004	2338	2672	3006	3340	3674	5010
10.00		159	255	318	477	637	796	955	1273	1592	1910	2228	2546	2865	3183	3501	4775
11.11	7/16	143	229	287	430	573	716	860	1146	1433	1719	2006	2292	2579	2865	3152	4298
12.00		133	212	265	398	531	663	796	1061	1326	1592	1857	2122	2387	2653	2918	3979
12.70	1/2	125	201	251	376	501	627	752	1003	1253	1504	1754	2005	2256	2506	2757	3760
14.00		114	182	227	341	455	568	682	909	1137	1364	1592	1819	2046	2274	2501	3410
14.29	9/16	111	178	223	334	446	557	668	891	1114	1337	1559	1782	2005	2228	2450	3341
15.00	–	106	170	212	318	424	531	637	849	1061	1273	1485	1698	1910	2122	2334	3183
15.88	5/8	100	160	200	301	401	501	601	802	1002	1203	1403	1604	1804	2004	2205	3007
16.00	–	99	159	199	298	398	497	597	796	995	1194	1393	1592	1790	1989	2188	2984
17.46	11/16	91	146	182	273	365	456	547	729	912	1094	1276	1458	1641	1823	2005	2735
18.00	–	88	141	177	265	354	442	531	707	884	1061	1238	1415	1592	1768	1945	2653
19.05	3/4	84	134	167	251	334	418	501	668	835	1003	1170	1337	1504	1671	1838	2506
20.00	–	80	127	159	239	318	398	477	637	796	955	1114	1273	1432	1592	1751	2387
24.00	–	66	106	133	199	265	332	398	531	663	796	928	1061	1194	1326	1459	1989
25.00	–	64	102	127	191	255	318	382	509	637	764	891	1019	1146	1273	1401	1910
27.00	–	59	94	118	177	236	295	354	472	589	707	825	943	1061	1179	1297	1768
30.00	–	53	85	106	159	212	265	318	424	531	637	743	849	955	1061	1167	1592
32.00	–	50	80	99	149	199	249	298	398	497	597	696	796	895	995	1094	1492
36.00	–	44	71	88	133	177	221	265	354	442	531	619	707	796	884	973	1326
40.00	–	40	64	80	119	159	199	239	318	398	477	557	637	716	796	875	1194
50.00	–	32	51	64	95	127	159	191	255	318	382	446	509	573	637	700	955



ALÉSOIRS – INFORMATIONS TECHNIQUES

Alésoirs : définitions et nomenclature

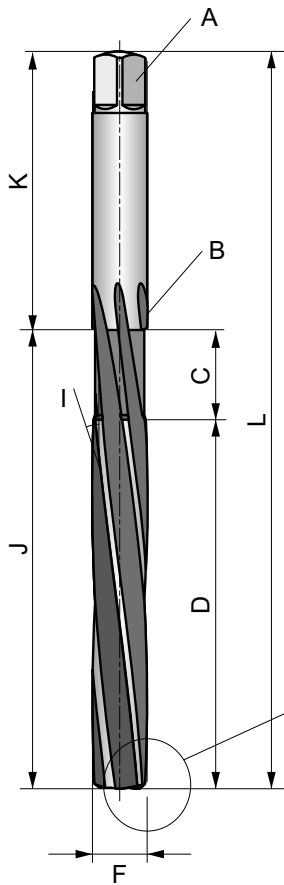

A	Tenon ou carré d'entraînement
B	Diamètre du détalonnage
C	Longueur du détalonnage
D	Longueur de coupe
E	Longueur du chanfrein d'entrée
F	Diamètre

G	Chanfrein d'entrée
H	Angle du chanfrein d'entrée
I	Angle d'hélice
J	Longueur de corps
K	Longueur queue
L	Longueur totale

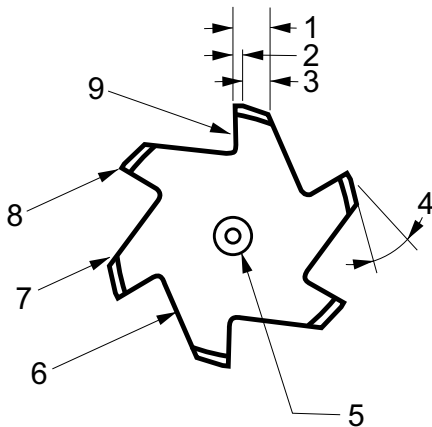
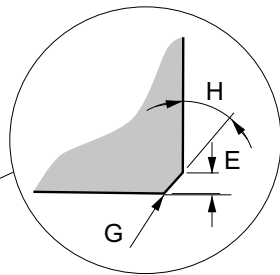

1	Largeur de listel
2	Dépouille cylindrique
3	Dépouille
4	Angle de dépouille
5	Trou de centre
6	Goujure
7	Listel
8	Arête de coupe
9	Face

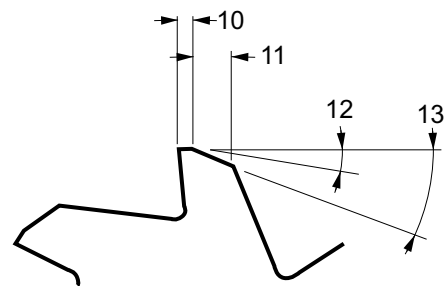

10	Largeur de dépouille primaire
11	Largeur de dépouille secondaire
12	Angle de dépouille primaire
13	Angle de dépouille secondaire

ALÉSOIRS – INFORMATIONS TECHNIQUES

Alesage

Pour obtenir les meilleurs résultats avec les alésoirs, il est important de les faire « travailler ». On fait souvent l'erreur de préparer les trous à aléser en y laissant une surépaisseur insuffisante. Si on ne laisse pas assez de surépaisseur dans le trou à aléser, le frottement entraîne une usure rapide de l'alésoir, avec pour conséquence une perte de diamètre. Pour de bons résultats, il est tout aussi important que la surépaisseur ne soit pas excessive. (Voir la section Enlèvement de matière ci-dessous).

1. Sélectionner le type d'alésoir le plus adapté ainsi que les conditions de vitesse de coupe et d'avance optimales pour l'application. Vérifiez que les trous percés ont un diamètre correct.
2. La pièce doit être maintenue de manière rigide et la broche de la machine ne doit pas avoir de jeu.
3. Le mandrin utilisé pour monter un alésoir à queue cylindrique doit être de bonne qualité. Si l'alésoir glisse dans le mandrin et si l'avance est automatique, l'alésoir risque de se casser.
4. Réduisez au minimum le porte-à-faux de l'outil par rapport à l'axe de la machine.

Enlèvement de surepaisseur

L'enlèvement de surépaisseur recommandé en alésage dépend du matériau de l'application et de la finition de surface du trou à aléser. Les recommandations de surépaisseur à enlever sont décrites dans les tableaux ci-dessous :

Diamètre du trou alésé (mm)	Sur avant trou au foret	Sur avant trou au foret alésoir
En dessous de 3/16	0.1	0.1
De 4 à 11	0.2	0.15
De 11 à 39	0.3	0.2
De 39 à 50	0.4	0.3

5. Utilisez les lubrifiants recommandés pour prolonger la durée de vie de l'alésoir et veillez à ce que le fluide atteigne toute les arêtes de coupe. Comme l'alésage n'est pas une opération de coupe difficile, une dilution 40:1 d'huile soluble convient généralement. De l'air comprimé peut être utilisé pour l'alésage à sec de la fonte grise.
6. Evitez le bourrage des copeaux dans les goujures d'un alésoir.
7. Avant d'affûter l'alésoir, vérifiez sa concentricité entre pointes. Dans la plupart des cas, seul le chanfrein d'entrée a besoin d'être réaffûté.
8. Veillez à ce que les alésoirs soient toujours bien affûtés. Un affûtage fréquent se justifie d'un point de vue économique, mais il ne faut pas oublier que les alésoirs ne coupent que sur le chanfrein et le cône d'entrée et non pas sur les listels de guidage. Par conséquent, seuls le chanfrein et le cône d'entrée doivent être réaffûtés. La précision de l'affûtage est importante tant pour la qualité du trou que pour la durée de vie de l'outil.

Diamètre du trou alésé (pouce)	Sur avant trou au foret	Sur avant trou au foret alésoir
En dessous de 3/16	0.004"	0.004"
3/16" à 1/2"	0.008"	0.006"
1/2" à 1,1/2"	0.010"	0.008"
1,1/2" à 2"	0.016"	0.010"

ALÉSAGE MANUEL / MACHINE

Bien que les alésoirs à main et les alésoirs machine offrent les mêmes possibilités en matière de dimensions de trou, le choix de l'un ou l'autre dépend de l'application. Un alésoir à main, pour une question d'alignement, a un long pas conique, alors qu'un alésoir machine n'a qu'un pas biseauté à 45 degrés. Un alésoir machine ne coupe que sur le biseau principal, tandis qu'un alésoir à main coupe sur le biseau principal et le cône d'entrée.

Les alésoirs les plus courants sont dotés d'une hélice à gauche car ils sont principalement utilisés pour réaliser des trous débouchants, donc en poussant les copeaux vers l'avant. Pour les trous borgnes, des alésoirs avec goujures droites ou hélice à droite sont recommandés. L'efficacité doit être calculée en fonction des conditions d'alésage : application, matériau, qualité du trou requis, enlèvement de matière, lubrification, etc. Un guide général des vitesses de coupe et d'avance pour les alésoirs machine est donné dans les tableaux d'avance et des

Groupes de matériaux à usiner WMG (voir le catalogue Dormer ou le configurateur de produits) et les tableaux d'enlèvement de matière. Avec une répartition très inégale des goujures, la division des dents n'est jamais la même. Comme aucune des dents n'est diamétralement opposée à une autre, l'alésoir produit un trou avec une variation réduite de la cylindricité comprise entre 1 et 2 µm. À titre de comparaison, cette variation de cylindricité peut aller jusqu'à 10 µm avec une répartition inégale conventionnelle.

Alésoirs au carbure – Comparaison répartition / répartition UE

répartition inégale
erreur de cylindricité jusqu'à 10 µm

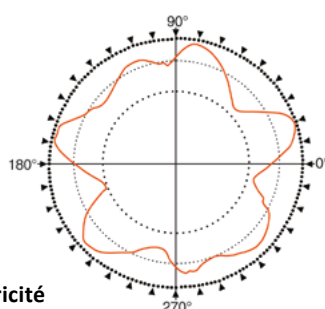

Résultats de cylindricité

répartition très inégale
erreur de cylindricité jusqu'à 1-2 µm

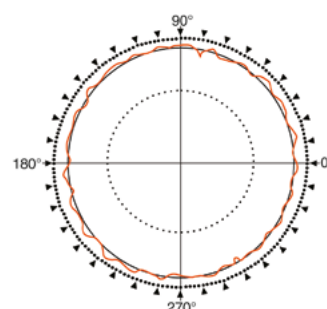

Résultats de cylindricité

ALÉSOIRS – LIMITES DE TOLÉRANCE – INFORMATIONS TECHNIQUES

Ecarts de tolérance



1. Sur le diamètre de coupe d'alesoirs standard

Le diamètre se mesure sur le listel de guidage juste derrière le chanfrein ou le cône d'entrée. La tolérance selon la DIN 1420 est destinée à produire des alésages H7.

Tolérance de l'alesoir			
Diamètre (mm)		Ecart de tolérance (mm)	
Supérieur	Jusqu'à et y compris	Elevé +	Faible +
-	3	0.008	0.004
3	6	0.010	0.005
6	10	0.012	0.006
10	18	0.015	0.008

Tolérance de l'alesoir			
Diamètre (mm)		Ecart de tolérance (mm)	
Supérieur	Jusqu'à et y compris	Elevé +	Faible +
18	30	0.017	0.009
30	50	0.021	0.012
50	80	0.025	0.014

2. Sur un alesage H7

La tolérance la plus commune pour un trou fini est H7 (voir le tableau ci-dessous). Pour toute autre tolérance les données en dessous du point 3 peuvent être utilisées pour la calculer.

Tolérance du trou			
Diamètre (mm)		Ecart de tolérance (mm)	
Supérieur	Jusqu'à et y compris	Elevé +	Faible +
-	3	0.010	0
3	6	0.012	0
6	10	0.015	0
10	18	0.018	0

Tolérance du trou			
Diamètre (mm)		Ecart de tolérance (mm)	
Supérieur	Jusqu'à et y compris	Elevé +	Faible +
18	30	0.021	0
30	50	0.025	0
50	80	0.030	0

3. Lorsqu'il est nécessaire de définir les dimensions d'un alésoir spécial destiné à produire une tolérance spécifique, par ex. D8, utilisez la formule suivante :

Amplitude de tolérance du diamètre (µm)								
Amplitude de tolérance (microns)	de 1 à 3	de 3 à 6	de 6 à 10	de 10 à 18	de 18 à 30	de 30 à 50	de 50 à 80	de 80 à 120
IT5	4	5	6	8	9	11	13	15
IT6	6	8	9	11	13	16	19	22
IT7	10	12	15	18	21	25	30	35
IT8	14	18	22	27	33	39	46	54
IT9	25	30	36	43	52	62	74	87
IT10	40	48	58	70	84	100	120	140
IT11	60	75	90	110	130	160	190	220
IT12	100	120	150	180	210	250	300	350

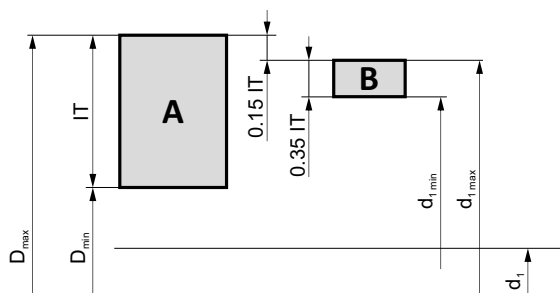

- A** = Tolérance du Trou
- B** = Tolérance de l'alesoir
- IT** = Amplitude de tolérance
- D_{max}** = Diamètre de trou max
- D_{min}** = Diamètre de trou min
- d₁** = Diamètre nominal
- d_{1max}** = Diamètre max de l'alesoir
- d_{1min}** = Diamètre min de l'alesoir

par ex. trou de 10 mm avec une tolérance D8, diam. max. = 10,062, diam. min. = 10,040, tol. alésage (IT8) = 0,022

Diamètre maximal : 0,15 x tolérance de l'alésage (IT8) = 0,0033, soit = 0,004

Diamètre minimal : 0,35 x tolérance de l'alésage (IT8) = 0,0077, soit = 0,008

Diamètre maximal de l'alesoir = 10,062 - 0,004 = 10,058

Diamètre minimal de l'alesoir = 10,058 - 0,008 = 10,050

TABLEAU DES AVANCES POUR LES ALÉSOIRS

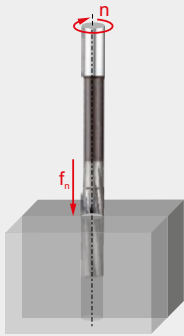

Avance par tour (f_n en mm/tr)
Ajuster ces valeurs de $\pm 15\%$ selon les conditions de travail.

Comment trouver l'avance par tour (f_n) grâce à ce tableau :

1. Rechercher le code Alpha sur la page produit (par ex. 21C, « C » étant le code Alpha).
2. Trouver le diamètre le plus proche de celui recherché pour votre application (première ligne du tableau).
3. Rechercher votre code Alpha dans la colonne gauche du tableau.
4. La cellule à l'intersection de la colonne Diamètre et de la ligne code Alpha indique l'avance par tour (f_n).

		ø DC (mm)																		
		1.00	1.50	2.00	3.00	4.00	5.00	6.00	7.00	8.00	10.00	12.00	15.00	16.00	20.00	25.00	30.00	40.00	50.00	80.00
Avances (mm/tr)	A	0.030	0.045	0.055	0.078	0.090	0.100	0.125	0.137	0.150	0.170	0.185	0.210	0.220	0.250	0.280	0.320	0.390	0.440	0.500
	B	0.035	0.055	0.072	0.110	0.130	0.150	0.165	0.172	0.180	0.210	0.240	0.270	0.280	0.310	0.360	0.400	0.500	0.550	0.600
	C	0.040	0.065	0.085	0.135	0.160	0.185	0.200	0.210	0.220	0.260	0.285	0.325	0.335	0.390	0.440	0.480	0.600	0.680	0.750
	D	0.050	0.080	0.110	0.160	0.180	0.200	0.235	0.253	0.270	0.320	0.360	0.400	0.410	0.470	0.540	0.600	0.730	0.850	0.950
	E	0.065	0.100	0.140	0.180	0.215	0.250	0.300	0.325	0.350	0.390	0.430	0.485	0.500	0.530	0.640	0.750	0.910	1.100	1.200
	F	0.090	0.140	0.180	0.260	0.305	0.350	0.395	0.417	0.440	0.500	0.550	0.610	0.630	0.700	0.800	0.930	1.200	1.500	1.650

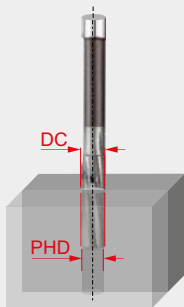

Tolérance d'usinage avec un **alésoir machine** (MA en mm)
Diamètre de préperçage
 $PHD = DC - MA$

Comment trouver le bon diamètre de préperçage (PHD) avec ce tableau :

1. Trouver la plage de diamètres la plus proche de celui recherché pour votre application (première ligne du tableau).
2. Rechercher votre code de groupe ISO dans la colonne gauche du tableau. Par ex. : le code de groupe ISO de l'acier inoxydable est « M ».
3. La cellule à l'intersection de la colonne Plage de Diamètre et de la ligne code de groupe ISO indique la tolérance d'usinage (MA).
4. Soustraire la tolérance d'usinage au diamètre d'alésage pour obtenir le diamètre de préperçage (PHD).

(Exemple : pour un trou de 6 mm dans l'acier (P), le $PHD = 5,85$ mm)

		ø DC (mm)											
		1.00	5.00	5.00	8.00	8.00	12.00	12.00	16.00	16.00	30.00	30.00	80.00
Groupe ISO	P	0.10			0.15		0.20		0.20		0.30		0.30
	M	0.08			0.10		0.10		0.20		0.20		0.30
	K	0.10			0.15		0.20		0.20		0.30		0.30
	N	0.10			0.15		0.20		0.20		0.30		0.30
	S	0.05			0.10		0.10		0.15		0.20		0.20
	H	0.05			0.05		0.10		0.10		0.15		0.20

Attention avec les tolérances d'usinage des forets : le diamètre de l'outil ne correspond pas au diamètre percé !

Remarque : la tolérance recommandée avec un alésoir à main se situe entre 0,05 et 0,10 mm.

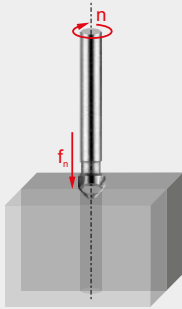
**TABLEAU DES AVANCES POUR LES FRAISES À CHANFREINER**

Avance par tour (f_n en mm/tr)
Ajuster ces valeurs de $\pm 15\%$ selon les conditions de travail.

Comment trouver l'avance par tour (f_n) grâce à ce tableau :

1. Rechercher le code Alpha sur la page produit (par ex. 23E, « E » étant le code Alpha).
2. Trouver le diamètre le plus proche de celui recherché pour votre application (première ligne du tableau).
3. Rechercher votre code Alpha dans la colonne gauche du tableau.
4. La cellule à l'intersection de la colonne Diamètre et de la ligne code Alpha indique l'avance par tour (f_n).

	$\varnothing DC$ (mm)										
	6.00	8.00	10.00	16.00	20.00	25.00	32.00	40.00	60.00	80.00	
Avances (mm/tr)	A	0.030	0.040	0.050	0.060	0.080	0.090	0.100	0.120	0.140	0.160
B	0.040	0.050	0.060	0.080	0.100	0.120	0.140	0.160	0.180	0.200	
C	0.050	0.060	0.080	0.100	0.120	0.140	0.160	0.180	0.200	0.220	
D	0.060	0.080	0.100	0.120	0.150	0.180	0.200	0.220	0.250	0.280	
E	0.080	0.100	0.120	0.150	0.180	0.200	0.250	0.270	0.300	0.320	
F	0.090	0.110	0.130	0.160	0.190	0.210	0.260	0.290	0.330	0.360	
G	0.100	0.120	0.150	0.180	0.200	0.220	0.280	0.320	0.360	0.400	
H	0.120	0.150	0.180	0.200	0.220	0.250	0.300	0.350	0.400	0.450	



HYDRA – INFORMATIONS TECHNIQUES

Tableau des couples de serrage des vis

					Valeurs de couple Nm	Valeurs de couple po/livres
H860	H861	Tête Hydra ø Plage (mm)	Tête Hydra ø Plage (fractions)	Tête Hydra ø Plage décimale (min. / max.)		
H860N1	H861N1	12.0 mm – 15.5 mm	15/32" – 39/64"	0.4688" – 0.6102"	0.75 – 0.99	6.6 – 8.8
H860N2	H861N2	15.6 mm – 18.5 mm	5/8" – 23/32"	0.6142" – 0.7283v	0.93 – 1.24	8.2 – 11.0
H860N3	H861N3	18.6 mm – 21.5 mm	47/64" – 27/32"	0.7323" – 0.8465"	1.84 – 2.44	16.3 – 21.6
H860N4	H861N3	22.0 mm – 24.5 mm	55/64" – 31/32"	0.8594" – 0.9688"	2.73 – 3.72	24.2 – 32.9
H860N5	H861N4	25.0 mm – 27.5 mm	63/64" – 1-3/32"	0.9843" – 1.0938"	4.14 – 5.52	36.6 – 48.8
H860N6	H861N5	28.0 mm – 33.5 mm	1-7/64" – 1-19/64"	1.1024" – 1.3189"	4.97 – 6.63	44.0 – 58.7
H860N7	H861N6	34.0 mm – 42.0 mm	1-11/32" – 1-5/8"	1.3386" – 1.6535"	7.2	63.7

Données vis et tournis

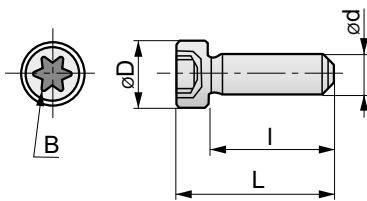

modèle	d	Pas	L (mm)	I (mm)	D (mm)	B
H860N1	M2.2	0.45	7.5	5.7	3.5	8IP
H860N2	M2.5	0.45	9.0	7.0	4.1	10IP
H860N3	M3.0	0.50	10.5	8.0	4.9	15IP
H860N4	M3.5	0.60	11.5	8.8	5.5	15IP
H860N5	M4.0	0.70	12.5	9.5	6.0	20IP
H860N6	M4.5	0.75	14.3	10.8	6.8	25IP

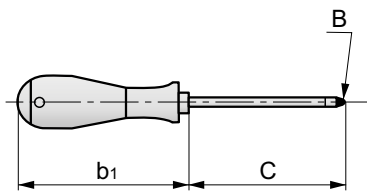

modèle	B	C	b ₁
H861N1	8IP	60	104
H861N2	10IP	80	111
H861N3	15IP	80	111
H861N4	20IP	100	118
H861N5	25IP	100	118

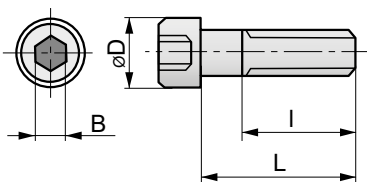

modèle	d	Pas	L (mm)	I (mm)	D (mm)	B
H860N7	M5.0	0.8	15	full	8.5	4

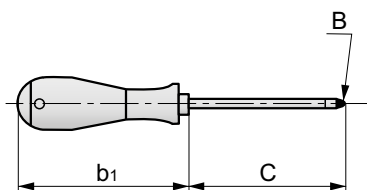

modèle	B	C	b ₁
H861N6	4	75	111

HYDRA – INFORMATIONS TECHNIQUES

Suivre une programmation spéciale pour les perçages 8×D et 12×D

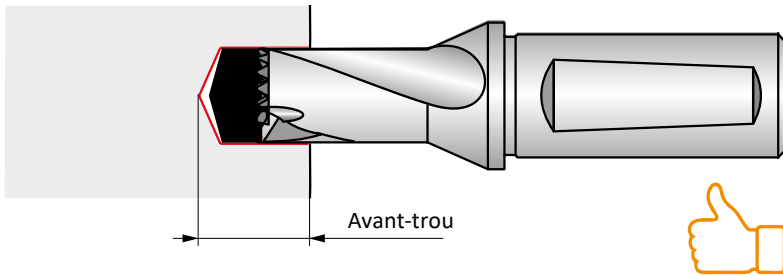

Perçer un avant-trou (1.5×D à 3×D de profondeur) avec une tête HYDRA de même diamètre (au besoin, vérifier l'excentricité: max. + 0,05 mm).

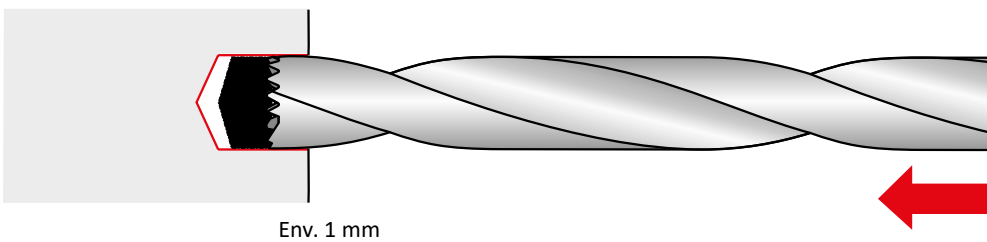

Rentrer le corps 8×D ou 12×D dans l'avant-trou à une vitesse de 500 tr/min maximum, jusqu'à environ 1 mm du fond de l'avant-trou.

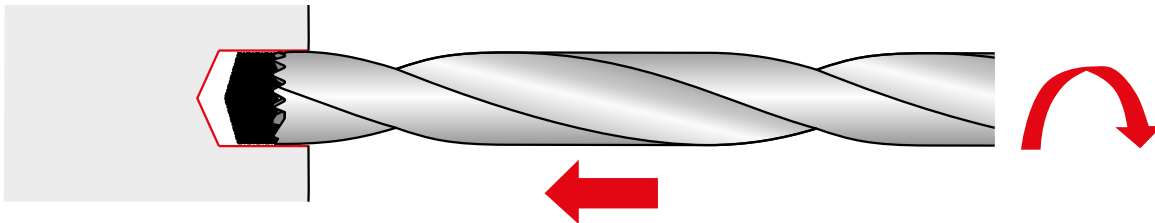

Activer le flux de fluide de coupe et augmenter la rotation jusqu'à la vitesse recommandée.

Remarque : limiter la durée de présence dans le trou et ne pas entamer l'avance avant que la rotation recommandée ait été atteinte.

Perçer jusqu'à la profondeur voulue sans déburrage.

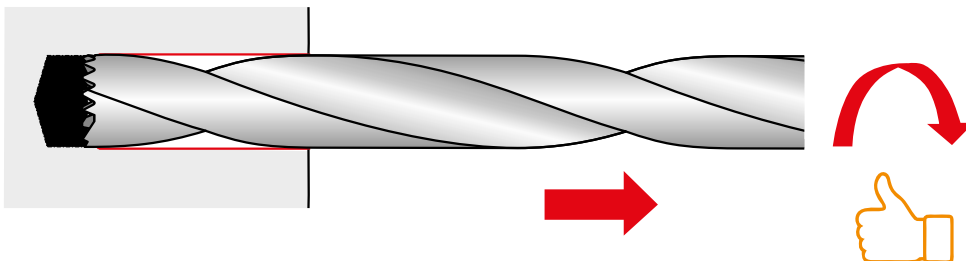

Une fois la profondeur atteinte, retirer le foret d'environ 0,1 mm à 0,5 mm et réduire la vitesse à 500 tr/min, puis retirer complètement le foret à vitesse d'avance normale. **Remarque : le fait de sortir le foret à une vitesse de broche plus élevée pourrait endommager l'épaulement ou la surface du trou et altérer la tolérance.**

HYDRA – INFORMATIONS TECHNIQUES

Conseils de perçage avec un foret hydra

Fluides de coupe

Pour une évacuation des copeaux et une performance de l'outil optimales, il est recommandé d'utiliser un fluide de coupe. Une concentration d'émulsion de fluide de coupe de 6 à 8 % est recommandée dans la plupart des applications, à une pression de 20 bar (290 PSI) ou plus. Pour l'acier à haute résistance, les aciers inoxydables et les matériaux tenaces, utiliser une concentration de 10 à 12 %. Dans ces applications, notamment avec les aciers inoxydables, il est recommandé d'utiliser la pression maximale de fluide de coupe sur la machine. Les trous d'arrosage des forets Hydra améliorent la résistance de l'âme et réduisent la chaleur au niveau des arêtes de coupe, ce qui augmente la productivité et la durée de vie de l'outil.

Porte-outils

Toujours utiliser des porte-outils et pinces de serrage pour assurer

une bonne concentricité entre le foret et la broche de la machine. Utiliser une butée pour empêcher l'outil de reculer dans le porte-outil. Le saut radial de l'outil dans le porte-outil doit être vérifié et maintenu avec précision.

Pièce usinée

La pièce à usiner doit être stable et correctement fixée pour limiter toute déviation, et améliorer la précision et le positionnement du trou.

Avances

Il est important d'assurer une avance suffisante du foret pour éviter qu'il ne stagne et ne s'émousse. Ceci est d'autant plus vrai dans les matériaux de trempe. Les avances doivent être suffisantes pour permettre une bonne formation de copeaux.

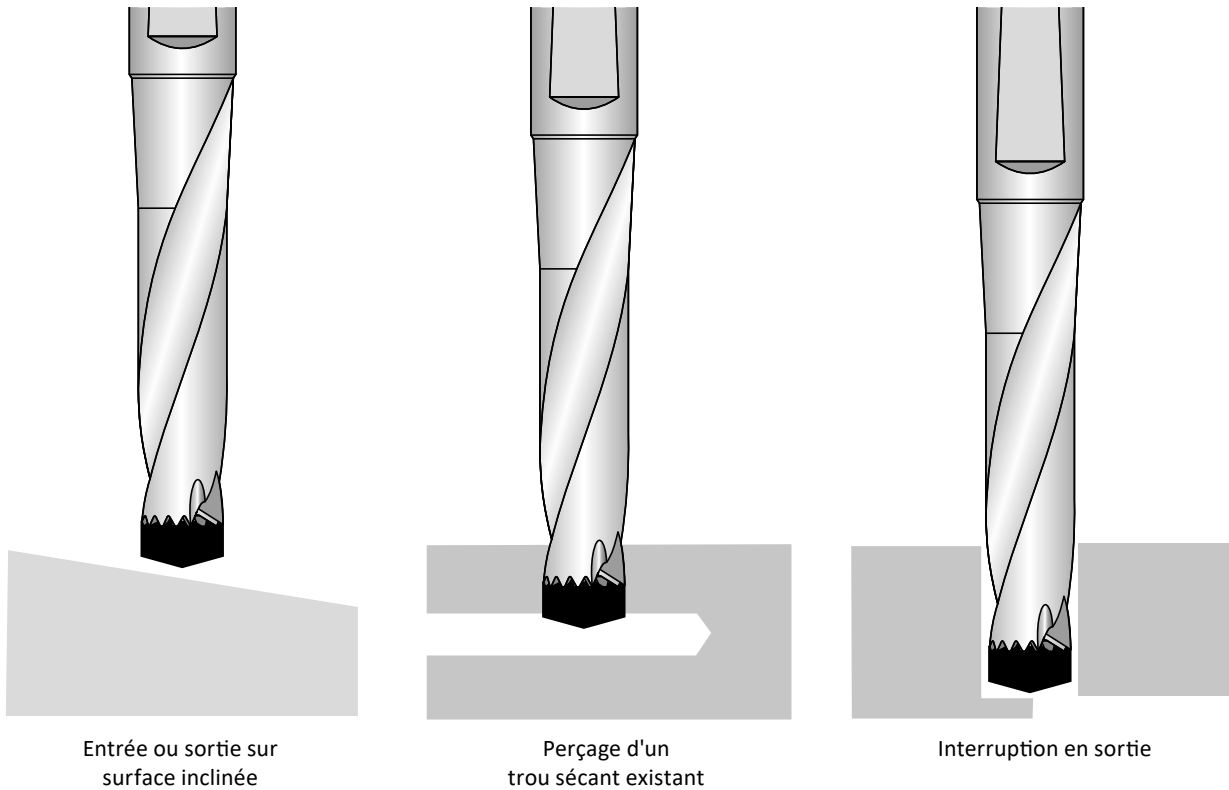

Dans ces situations, il est généralement recommandé de réduire l'avance de 1/3 (33 %). Le perçage avec un angle d'entrée de plus de 10° n'est PAS recommandé. Il est conseillé d'usinier la surface pour qu'elle soit plane avant de percer.

CARACTÉRISTIQUES D'USINAGE POUR LES FORETS A PLAQUETTES

Ajustement radial

Ajustement du diamètre du trou et recommandations de réglage

Il est possible de régler radialement un foret à plaquettes afin d'obtenir un trou de diamètre plus petit ou plus grand que le diamètre de foret. Les valeurs d'ajustement radial sont présentées dans le tableau des caractéristiques générales des forets.

Outil rotatif

Un support ajustable est recommandé pour le réglage du diamètre d'un trou d'une précision IT10 ou plus avec les forets rotatifs de la série 80xD.

Outil fixe

Lors du montage du foret, s'assurer que le centre du foret et le centre de la pièce à usiner sont alignés. Pour un diamètre de trou plus important, déplacer le foret afin que la plaquette périphérique parte de l'axe central de la pièce.

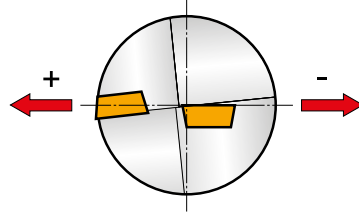

Duree de vie d'outil

Les plaquettes ne doivent pas être utilisées lorsque l'usure en dépouille excède $0,2 \div 0,4$ mm au point le plus important. Les recommandations de vitesse de coupe mentionnées dans ce catalogue sont basées sur une durée de vie de plaquette périphérique représentant une longueur totale de trou percé de 7 m (durabilité $20 \div 30$ min.)

EP

DOUILLE DE RÉGLAGE

Diam. de queue	Diam. de foret	Plage
25	15 – 24	+0.4 – -0.2
32	24.5 – 40	+0.4 – -0.2

Ajustement de diamètre pour centre d'usinage

Plage d'ajustement de diamètre

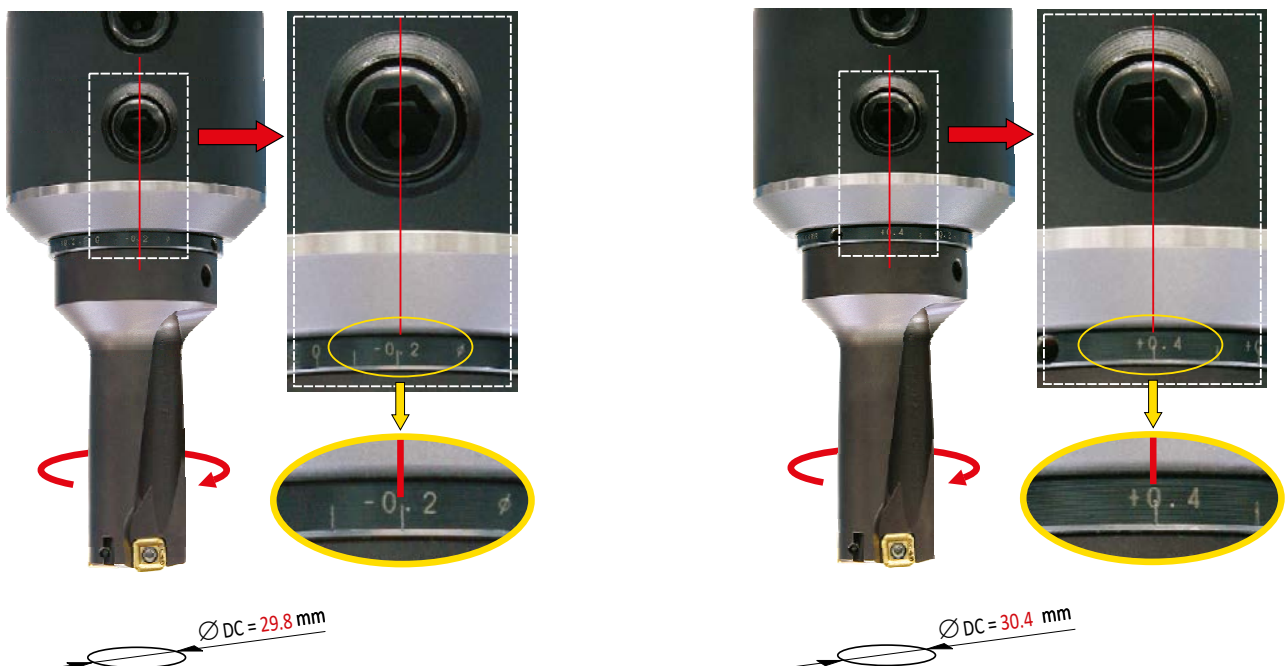

EP

RÉGLAGE DES FORETS À PLAQUETTES

Diam. de queue	Diam. de foret	Plage
25	15 – 24	+0.2 – -0.15
32	24.5 – 40	+0.2 – -0.15

Ajustement de hauteur/centrage
– pour les opérations de tournage

Plage d’ajustement de hauteur et de centrage

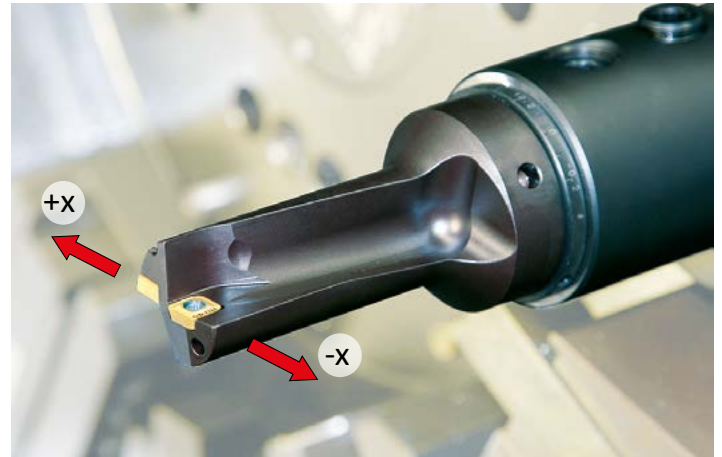

CARACTÉRISTIQUES D’USINAGE POUR LES FORETS À PLAQUETTES

Pression recommandée du liquide de coupe

Diamètre de foret DC (mm)	Pression du liquide de coupe	
	Longueur de foret	
	2.0 – 2.5 DC	3.0 – 5.0 DC
15 – 25	6 bar	12 bar
26 – 40	4.5 bar	9 bar
> 40	3 bar	6 bar

Débit de liquide de refroidissement nécessaire

PERÇAGE À SEC

Il est possible de percer sans liquide de refroidissement dans la fonte et l’acier, à condition d’utiliser de l’air comprimé à travers le foret.

Puissance nette requise

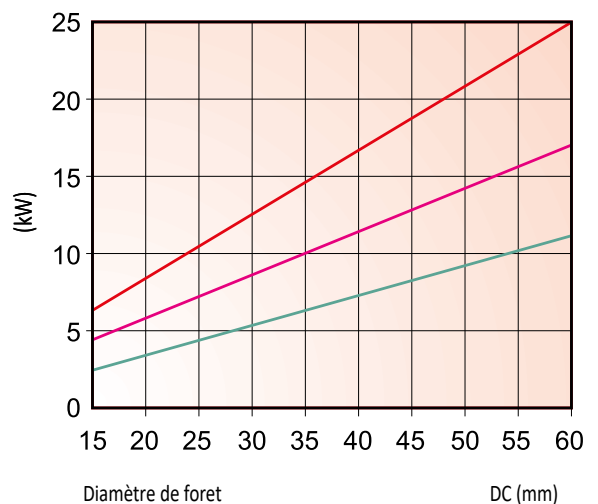
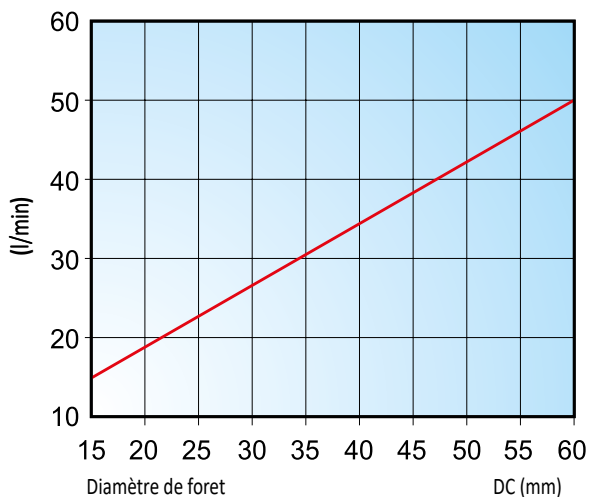



DONNÉES D'USINAGE COURANTES

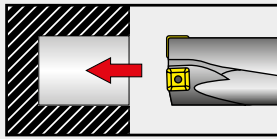

PERÇAGE D'UN TROU BORGNE

L'arrosage est nécessaire pour un trou plus profond que $1xD$

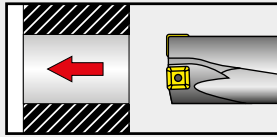

PERÇAGE D'UN TROU DÉBOUCHANT

Une rondelle peut être produite lors de la sortie du foret hors de la pièce. Pour la sécurité de l'opérateur, il est essentiel d'équiper la machine de dispositifs de protection.

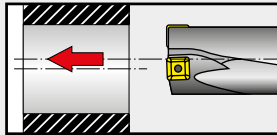

PERÇAGE EXCENTRÉ

Diminuer l'avance jusqu'au plus bas de celle recommandée pour les plaquettes sélectionnées. Voir les pages géométries de plaquettes. Ne pas dépasser les valeurs de réglage radial.

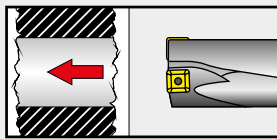

ALÉSAGE SUR DES SURFACES IRREGULIÈRES ET MOULÉES

Diminuer l'avance à la pénétration des forets à plaquettes indexables, jusqu'à ce que les deux plaquettes soient engagées.

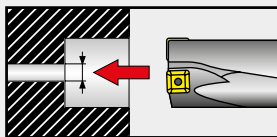

ALÉSAGE ET PERÇAGE DANS UN TROU PRÉ-PERCÉ

Si le trou pré-percé est supérieur à $1/4$ du diamètre de foret, diminuer l'avance.

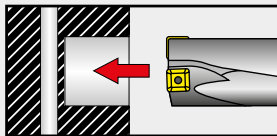

PERÇAGE A TRAVERS UN TROU EXISTANT

Diminuer l'avance de 50% lors d'un perçage à travers un trou existant. Le diamètre du trou existant ne doit pas dépasser $0,25xD$.

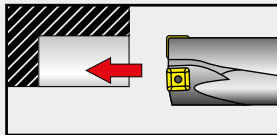

COUPE INTERROMPUE ET TRÉFLAGE

Diminuer l'avance jusqu'au plus bas de celle recommandée pour les plaquettes sélectionnées. Voir les pages géométries de plaquettes.

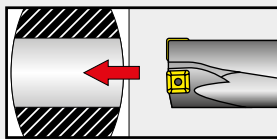

PERÇAGE SUR SURFACE INCURVÉE

Le perçage centré peut être effectué avec une avance réduite à 50% en entrée et en sortie.

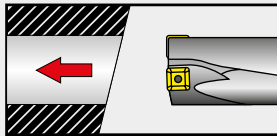

PERÇAGE SUR DES SURFACES INCLINÉES

Diminuer l'avance de 50% à la pénétration des forets à plaquettes indexées, jusqu'à ce que les deux plaquettes soient engagées si l'angle d'entrée est supérieur à 5° .

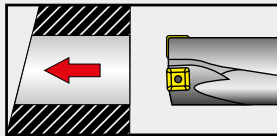

SORTIE DE SURFACE INCLINÉE

Diminuer l'avance de 50%, si l'angle de sortie est supérieur à 5° .

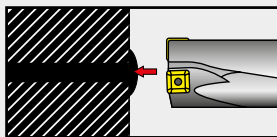

AMORÇAGE SUR UN POINT DE SOUDURE

Un dressage est recommandé avant le perçage. Diminuer l'avance de 50% pendant le perçage du matériau soudé.

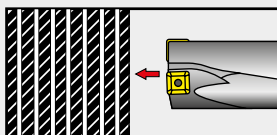

PERÇAGE DE MATÉRIAUX EMPILÉS

Éviter des écarts de plus de 0,2 mm entre couches. La pièce doit être fermement fixée. Il est nécessaire de réduire l'avance.



FORETS À PLAQUETTES – CONDITIONS DE COUPE RECOMMANDÉES

802D, 803D (XPET..AP, SCET..-UD)



	D9335	D8330	D8345	ø 15	ø 20	ø 25	ø 30	ø 40	ø 58
P1	■	■	■	0.07	0.08	0.09	0.10	0.12	0.16
P2	■	■	■	0.11	0.13	0.15	0.17	0.21	0.28
P3	■	■	■	0.13	0.15	0.18	0.20	0.24	0.32
P4	■	■	■	0.12	0.14	0.16	0.18	0.22	0.30
K1	■	■	■	0.14	0.16	0.19	0.21	0.26	0.34
K2	■	■	■	0.14	0.16	0.19	0.21	0.26	0.34
K3	■	■	■	0.14	0.16	0.19	0.21	0.26	0.34
K4	■	■	■	0.14	0.16	0.19	0.21	0.26	0.34
K5	■	■	■	0.14	0.16	0.19	0.21	0.26	0.34

802D, 803D (XPET..AP-SD, SCET..-SD)



	D9335	D8330	D8345	ø 15	ø 20	ø 25	ø 30	ø 40	ø 58
P1	■	■	■	0.08	0.09	0.10	0.11	0.14	0.18
P2	■	■	■	0.11	0.13	0.15	0.17	0.21	0.28
P3	■	■	■	0.13	0.15	0.18	0.20	0.24	0.32
P4	■	■	■	-	-	-	-	-	-
K1	☑	☑	☑	0.08	0.09	0.10	0.11	0.14	0.18
K2	☑	☑	☑	0.11	0.13	0.15	0.17	0.21	0.28
K3	☑	☑	☑	0.12	0.14	0.16	0.18	0.22	0.24
K4	☑	☑	☑	0.13	0.15	0.18	0.20	0.24	0.32
K5	☑	☑	☑	0.14	0.16	0.19	0.21	0.25	0.33
M1	■	■	■	0.12	0.14	0.16	0.18	0.22	0.30
M2	■	■	■	0.11	0.13	0.15	0.17	0.21	0.28
M3	■	■	■	0.07	0.08	0.09	0.10	0.12	0.16
M4	■	■	■	0.07	0.08	0.09	0.10	0.12	0.16
S1	☑	☑	☑	0.08	0.09	0.10	0.11	0.14	0.18
S2	☑	☑	☑	0.08	0.09	0.10	0.11	0.14	0.18
S3	☑	☑	☑	0.07	0.08	0.09	0.10	0.12	0.16
S4	☑	☑	☑	0.07	0.08	0.09	0.10	0.12	0.16

804D (XPET..AP, SCET..-UD)



	D9335	D8330	D8345	ø 15	ø 20	ø 25	ø 30	ø 40	ø 58
P1	■	■	■	0.06	0.07	0.08	0.09	0.10	0.14
P2	■	■	■	0.10	0.12	0.14	0.16	0.19	0.25
P3	■	■	■	0.12	0.14	0.16	0.18	0.22	0.30
P4	■	■	■	0.11	0.13	0.15	0.17	0.21	0.28
K1	■	■	■	0.13	0.15	0.18	0.20	0.24	0.32
K2	■	■	■	0.13	0.15	0.18	0.20	0.24	0.32
K3	■	■	■	0.13	0.15	0.18	0.20	0.24	0.32
K4	■	■	■	0.13	0.15	0.18	0.20	0.24	0.32
K5	■	■	■	0.13	0.15	0.18	0.20	0.24	0.32

FORETS À PLAQUETTES – CONDITIONS DE COUPE RECOMMANDÉES

804D (XPET..AP-SD, SCET..-SD)



	D9335	D8330	D8345	∅ 15	∅ 20	∅ 25	∅ 30	∅ 40	∅ 58
P1	■	■	■	0.07	0.08	0.09	0.10	0.12	0.16
P2	■	■	■	0.10	0.12	0.14	0.16	0.19	0.25
P3	■	■	■	0.12	0.14	0.16	0.18	0.22	0.30
P4	■	■	■	–	–	–	–	–	–
K1	☑	☑	☑	0.07	0.08	0.09	0.10	0.12	0.16
K2	☑	☑	☑	0.10	0.12	0.14	0.16	0.19	0.25
K3	☑	☑	☑	0.11	0.13	0.15	0.17	0.20	0.27
K4	☑	☑	☑	0.12	0.14	0.16	0.18	0.22	0.30
K5	☑	☑	☑	0.14	0.16	0.19	0.21	0.25	0.33
M1	■	■	■	0.11	0.13	0.15	0.17	0.21	0.28
M2	■	■	■	0.10	0.12	0.14	0.16	0.19	0.25
M3	■	■	■	0.06	0.07	0.08	0.09	0.10	0.14
M4	■	■	■	0.06	0.07	0.08	0.09	0.10	0.14
S1	☑	☑	☑	0.07	0.08	0.09	0.10	0.12	0.16
S2	☑	☑	☑	0.07	0.08	0.09	0.10	0.12	0.16
S3	☑	☑	☑	0.06	0.07	0.08	0.09	0.10	0.14
S4	☑	☑	☑	0.06	0.07	0.08	0.09	0.10	0.14

805D (XPET..AP, SCET..-UD)



	D9335	D8330	D8345	∅ 15	∅ 20	∅ 25	∅ 30	∅ 40	∅ 58
P1	■	■	■	0.06	0.07	0.08	0.09	0.10	0.14
P2	■	■	■	0.10	0.12	0.14	0.16	0.19	0.25
P3	■	■	■	0.12	0.14	0.16	0.18	0.22	0.30
P4	■	■	■	0.11	0.13	0.15	0.17	0.21	0.28
K1	■	■	■	0.13	0.15	0.18	0.20	0.24	0.32
K2	■	■	■	0.13	0.15	0.18	0.20	0.24	0.32
K3	■	■	■	0.13	0.15	0.18	0.20	0.24	0.32
K4	■	■	■	0.13	0.15	0.18	0.20	0.24	0.32
K5	■	■	■	0.13	0.15	0.18	0.20	0.24	0.32

805D (XPET..AP-SD, SCET..-SD)



	D9335	D8330	D8345	∅ 15	∅ 20	∅ 25	∅ 30	∅ 40	∅ 58
P1	■	■	■	0.07	0.08	0.09	0.10	0.12	0.16
P2	■	■	■	0.10	0.12	0.14	0.16	0.19	0.25
P3	■	■	■	0.12	0.14	0.16	0.18	0.22	0.30
P4	■	■	■	–	–	–	–	–	–
K1	☑	☑	☑	0.07	0.08	0.09	0.10	0.12	0.16
K2	☑	☑	☑	0.10	0.12	0.14	0.16	0.19	0.25
K3	☑	☑	☑	0.11	0.13	0.15	0.17	0.20	0.27
K4	☑	☑	☑	0.12	0.14	0.16	0.18	0.22	0.30
K5	☑	☑	☑	0.12	0.14	0.16	0.18	0.22	0.30
M1	■	■	■	0.11	0.13	0.15	0.17	0.21	0.28
M2	■	■	■	0.10	0.12	0.14	0.16	0.19	0.25
M3	■	■	■	0.06	0.07	0.08	0.09	0.10	0.14
M4	■	■	■	0.06	0.07	0.08	0.09	0.10	0.14
S1	☑	☑	☑	0.07	0.08	0.09	0.10	0.12	0.16
S2	☑	☑	☑	0.07	0.08	0.09	0.10	0.12	0.16
S3	☑	☑	☑	0.06	0.07	0.08	0.09	0.10	0.14
S4	☑	☑	☑	0.06	0.07	0.08	0.09	0.10	0.14

FORMULES DE CALCUL DES PARAMÈTRES DE COUPE

NOMENCLATURES ET FORMULES

Paramètre	Formule	Unité
Vitesse de rotation	$n = \frac{v_c \cdot 1000}{DC \cdot \pi}$	(tr/min)
Vitesse de coupe	$v_c = \frac{\pi \cdot DC \cdot n}{1000}$	(m/min)
Avance de table	$v_f = n \cdot f$	(mm/min)
Section transversale du trou	$A = \frac{\pi \cdot DC^2}{4}$	(mm ²)
Taux d'enlèvement de métal	$Q = \frac{v_f \cdot A}{1000}$	(cm ³ /min)
Durée d'usinage	$T_c = \frac{L + h}{v_f}$	(min/pièce)

DC Diamètre du foret

f Avance par tour

(mm)

(mm/tr)

h Distance entre la pointe du foret et la pièce à usiner avant l'avance (mm)

L Profondeur du trou

(mm)

COUPLES DE SERRAGE RECOMMANDÉS POUR LES VIS

	Nm					
US 2245-T07P	0.9	FLAG T07P	M 2.2	5.3	D-T7P	MR-0.8-2.0 vario
US 2205-T07P	0.9	FLAG T07P	M 2.2	5.4	D-T7P	MR-0.8-2.0 vario
US 2506-T07P	1.2	FLAG T07P	M 2.5	6	D-T7P	MR-0.8-2.0 vario
US 2507-T08P	1.2	FLAG T08P	M 2.5	7	D-T8P	MR-0.8-2.0 vario
US 3007-T08P	2.0	FLAG T08P	M 3	7	D-T8P	MR-1.0-5.0 vario
US 3007-T09P	2.0	FLAG T09P	M 3	7.4	D-T9P	MR-1.0-5.0 vario
US 3009-T09P	2.0	FLAG T09P	M 3	8.7	D-T9P	MR-1.0-5.0 vario
US 3508-T15P	3.0	FLAG T15P	M 3.5	8.3	D-T15P	MR-1.0-5.0 vario
US 3510-T15P	3.0	FLAG T15P	M 3.5	10.6	D-T15P	MR-1.0-5.0 vario
US 4011-T15P	3.5	FLAG T15P	M 4	10.7	D-T15P	MR-1.0-5.0 vario
US 5012-T15P	5.0	FLAG T15P	M 5	12.2	D-T15P	MR-1.0-5.0 vario



GROUPES DE MATÉRIAUX À USINER (WMG)

Groupe ISO	Groupes de matériaux à usiner (WMG)		Dureté (HB ou HRC)	Résistance à la traction max. (MPa)		
P	P1	P1.1	Manganèse	< 240 HB	≤ 830	
		P1.2	Acier de décolletage	Manganèse et phosphore	< 180 HB	≤ 620
		P1.3	(aciers au carbone, usinabilité accrue)	Manganèse/phosphore et plomb	< 180 HB	≤ 620
	P2	P2.1	Acier simple au carbone (aciers principalement composés de fer et de carbone)	Teneur en carbone <0,25 %c	< 180 HB	≤ 620
		P2.2		Teneur en carbone <0,55 %c	< 240 HB	≤ 830
		P2.3		Teneur en carbone <0,55 %c	< 300 HB	≤ 1030
	P3	P3.1	Acier allié (aciers au carbone avec une teneur en alliage ≤ 10 %)	Recuit	< 180 HB	≤ 620
		P3.2		Durci et trempé	180 – 260 HB	> 620 ≤ 900
		P3.3			260 – 360 HB	> 900 ≤ 1240
	P4	P4.1	Acier à outil (acier allié spécial pour outils, moules et matrices)	Recuit	< 26 HRC	≤ 900
P4.2		Durci et trempé		26 – 39 HRC	> 900 ≤ 1240	
P4.3				39 – 45 HRC	> 1240 ≤ 1450	
M	M1	M1.1	Acier inoxydable ferritique (alliages non durcissables au chrome droit)	< 160 HB	≤ 520	
		M1.2		160 – 220 HB	> 520 ≤ 700	
	M2	M2.1	Acier inoxydable martensitique (alliages durcissables au chrome droit)	Recuit	< 200 HB	≤ 670
		M2.2		Revenu et trempé	200 – 280 HB	> 670 ≤ 950
		M2.3		Durci par précipitation	280 – 380 HB	> 950 ≤ 1300
	M3	M3.1	Acier inoxydable austénitique (alliages chrome-nickel et chrome-nickel-manganèse)	< 200 HB	≤ 750	
		M3.2		200 – 260 HB	> 750 ≤ 870	
		M3.3		260 – 300 HB	> 870 ≤ 1040	
	M4	M4.1	Acier inoxydable super-austénitique et austéno-ferritique (duplex)	< 300 HB	≤ 990	
		M4.2	Acier inoxydable austénitique à durcissement par précipitation	300 – 380 HB	≤ 1320	
K	K1	K1.1	Fonte grise (ASTM A48) ou fonte grise pour l'automobile (ASTM A159) (pièces moulées en fer-carbone avec micro-structure graphite lamellaire)	Ferritique ou ferritique-perlitique	< 180 HB	≤ 190
		K1.2		Ferritique-perlitique ou perlitique	180 – 240 HB	> 190 ≤ 310
		K1.3		Perlitique	240 – 280 HB	> 310 ≤ 390
	K2	K2.1	Fonte malléable (ASTM A602) (pièces moulées en fer-carbone avec micro-structure sans graphite)	Ferritique	< 160 HB	≤ 400
		K2.2		Ferritique ou perlitique	160 – 200 HB	> 400 ≤ 550
		K2.3		Perlitique	200 – 240 HB	> 550 ≤ 660
	K3	K3.1	Fonte malléable (ASTM A536) (pièces moulées en fer-carbone avec micro-structure en graphite nodulaire)	Ferritique	< 180 HB	≤ 560
		K3.2		Ferritique ou perlitique	180 – 220 HB	> 560 ≤ 680
		K3.3		Perlitique	220 – 260 HB	> 680 ≤ 800
	K4	K4.1	Fonte grise austénitique (ASTM A436) (pièces moulées en alliage fer-carbone avec micro-structure graphite lamellaire austénitique)	< 180 HB	≤ 190	
		K4.2	Fonte malléable austénitique (ASTM A439 ou ASTM A571) (alliage fer-carbone avec micro-structure graphite nodulaire austénitique)	< 240 HB	≤ 740	
		K4.3	Fonte malléable à trempe étagée (ASTM A897) (alliage fer-carbone avec micro-structure ausferritique)	< 280 HB	> 840 ≤ 980	
		K4.4		280 – 320 HB	> 980 ≤ 1130	
K4.5		320 – 360 HB		> 1130 ≤ 1280		
K5	K5.1	Fonte à graphite vermiculaire compactée (ASTM A842) (pièces moulées en fer-carbone avec structure graphite vermiculaire)	Ferritique	< 180 HB	≤ 400	
	K5.2		Ferritique-perlitique	180 – 220 HB	> 400 ≤ 450	
	K5.3		Perlitique	220 – 260 HB	> 450 ≤ 500	
N	N1	N1.1	Aluminium pur corroyé	< 60 HB	≤ 240	
		N1.2		Semi-trempé	60 – 100 HB	> 240 ≤ 400
		N1.3		Trempé	100 – 150 HB	> 400 ≤ 590
	N2	N2.1	Alliages d'aluminium corroyé	< 75 HB	≤ 240	
		N2.2		75 – 90 HB	> 240 ≤ 270	
		N2.3		90 – 140 HB	> 270 ≤ 440	
	N3	N3.1	Alliages de cuivre de décolletage avec d'excellentes propriétés d'usinage	–	–	
		N3.2	Alliages de cuivre à copeaux courts avec des propriétés d'usinage bonnes à moyennes	–	–	
		N3.3	Alliages de cuivre à longs copeaux et cuivre électrolytique avec des propriétés d'usinage médiocres à moyennes	–	–	
			N4.1	Polymères et thermoplastiques	–	–
N4	N4.2	Polymères thermodurcissables	–	–		
	N4.3	Polymères renforcés ou composites	–	–		
N5	N5.1	Graphite	–	–		
S	S1	S1.1	Titane ou alliages de titane	< 200 HB	≤ 660	
		S1.2		200 – 280 HB	> 660 ≤ 950	
		S1.3		280 – 360 HB	> 950 ≤ 1200	
	S2	S2.1	Alliages à base de fer haute température	< 200 HB	≤ 690	
		S2.2		200 – 280 HB	> 690 ≤ 970	
	S3	S3.1	Alliages à base de nickel haute température	< 280 HB	≤ 940	
		S3.2		280 – 360 HB	> 940 ≤ 1200	
	S4	S4.1	Alliages à base de cuivre haute température	< 240 HB	≤ 800	
S4.2		240 – 320 HB		> 800 ≤ 1070		
H	H1	H1.1	Fonte en coquille	< 440 HB	–	
	H2	H2.1	Fonte trempée	< 55 HRC	–	
		H2.2		> 55 HRC	–	
	H3	H3.1	Acier trempé < 55 HRC	< 51 HRC	–	
		H3.2		51 – 55 HRC	–	
	H4	H4.1	Acier trempé > 55 HRC	55 – 59 HRC	–	
H4.2		> 59 HRC		–		



TABLE DE CONVERSION DE DURETÉ

Résistance (MPa)	Dureté			
	BRINELL	VICKERS	ROCKWELL	ROCKWELL
R_m	HB	HV	HRB	HRC
285	86	90	1190	–
320	95	100	56.2	–
350	105	110	62.3	–
385	114	120	66.7	–
415	124	130	71.2	–
450	133	140	75.0	–
480	143	150	78.7	–
510	152	160	81.7	–
545	162	170	85.8	–
575	171	180	87.1	–
610	181	190	89.5	–
640	190	200	91.5	–
675	199	210	93.5	–
705	209	220	95	–
740	219	230	96.7	–
770	228	240	98.1	–
800	238	250	99.5	–
820	242	255	–	23.1
850	252	265	–	24.8
880	261	275	–	26.4
900	266	280	–	27.1
930	276	290	–	28.5
950	280	295	–	29.2
995	295	310	–	31.0
1030	304	320	–	32.2
1060	314	330	–	33.3
1095	323	340	–	34.4
1125	333	350	–	35.5
1155	342	360	–	36.6

Résistance (MPa)	Dureté			
	BRINELL	VICKERS	ROCKWELL	ROCKWELL
R_m	HB	HV	HRB	HRC
1190	352	370	–	37.7
1220	361	380	–	38.8
1255	371	390	–	39.8
1290	380	400	–	40.8
1320	390	410	–	41.8
1350	399	420	–	42.7
1385	409	430	–	43.6
1420	418	440	–	44.5
1455	428	450	–	45.3
1485	437	460	–	46.1
1520	447	470	–	46.9
1555	456	480	–	47.7
1595	466	490	–	48.4
1630	475	500	–	49.1
1665	485	510	–	49.8
1700	494	520	–	50.5
1740	504	530	–	51.1
1775	513	540	–	51.7
1810	523	550	–	52.3
1845	532	560	–	53.0
1880	542	570	–	53.6
1920	551	580	–	54.1
1955	561	590	–	54.7
1995	570	600	–	55.2
2030	580	610	–	55.7
2070	589	620	–	56.3
2105	599	630	–	56.8
2145	608	640	–	57.3
2180	618	650	–	57.8

SIMPLY RELIABLE

Un copeau peut vous raconter une histoire de part sa forme et son fractionnement. En tant que professionnel, vous pouvez juger de la qualité d'un usinage rien qu'en le regardant. Le copeau envoie un message clair et évident, c'est pourquoi nous l'avons choisi comme symbole, **efficace tout simplement.**

DORMER PRAMET

www.dormerpramet.com



**CONTACTEZ VOTRE
SERVICE CLIENTS LOCAL
TOUJOURS À JOUR!**



DP-CAT-HOLEMAKING-2024-FR

FOLLOW US...



ONLINE



SEGMENTS



LIBRARY APP.



CALCULATOR APP.