

DORMER PRAMET

**FRAISAGE
MONOBLOC**



2024



DORMER

FRAISAGE MONOBLOC – CONTENU GÉNÉRAL

Navigateur (par matériau à usiner)			P	M	K	N	S	H	
FRAISAGE MONOBLOC Outils pour la fabrication de base, l'entretien, la réparation, la révision. Généralement utilisés avec des machines conventionnelles. Convient pour des paramètres de coupe faibles.		Rainurage	C1 C3	C1 C3	C1 C3	C366			5
		Ebauche	C9 C4	C908 C948	C9 C4	C9 C4	C908 C948		25
		Semi-finition	C2	C2	C2	C333 C2	C2		35
		Finition et copiage	C5 C907 C920	C5 C907 C920	C2 C907 C920	C159	C907 C920		45
		Fraises de forme	C8 C7	C8 C7	C8 C7	C8 C7	C8 C7		49
		Fraises disques et fraises 3T	D2 D7 D4	D2 D7 D4	D2 D7 D4	D2 D7 D4	D2 D76 D42		54
		Gamme de base de fraises carbure	S9		S9	S9			69
Outils en carbure monobloc pour la fabrication mixte. Convient aux paramètres de coupe modérés.		Rainurage	S8	S71.	S8	S8	S71.		79
		Semi-finition	S8	S71.	S8	S8	S71.		95
Outils en carbure monobloc pour des processus productifs et sécurisés. Généralement utilisés avec des machines à commande numérique et pour la fabrication automatisée. Utilisables avec des paramètres de coupe élevés.		Chanfreinage	S739 S740	S739 S740	S739 S740		S739 S740		105
		Ebauche et grande avance (HFC)	S765	S765	S765	S6..	S765	S536 (HFC)	109
		Fraisage trochoïdal	S77.	S77.	S77.		S77.	S52.	121
		Semi-finition	S76.	S26.	S76.	S662 S612	S76.	S5	126
		Finition	S768	S2	S768		S2	S5	145
		Copiage	S791	S2 S791	S511	S629	S2	S5	153
		Fraisage de filets	Formes de filets : M, MF, UNC, UNF, G, NPT						
FRAISES LIMES		(en fonction de l'aptitude)	P ST	M VA	PMKSH DC	N AL GRP	S AS	Sets P100 P101	180

INSTRUCTIONS	Comment lire les données du catalogue ? (ISO 13399, icônes, navigation)								250	
	Vue d'ensemble des matériaux et des revêtements								256	
	Fraises HSS + HM – Informations techniques								257	
	 HSS	Tableaux des vitesses d'avance, corrections				261	 HM	Tableaux des vitesses d'avance, corrections		266
	Fraises à fileter – Conseils				271	Tableaux des vitesses d'avance				272
	Fraises limes – Conseilss				275	Vitesses de fonctionnement				277
	Groupes de matériaux à usiner (WMG)								278	



OUTILS ROTATIFS MONOBLOCS – CONTENU (PAR ORDRE ALPHABÉTIQUE)

FAMILLE		FAMILLE		FAMILLE		FAMILLE	
C		P		S		S804HA	96
C110	6	P100	246	S219	137	S804HB	97
C122	16	P101	247	S225	146	S812HA	82
C123	11	P501	234	S226	147	S812HB	83
C126	8	P505	235	S227	148	S813HA	88
C135	15	P507	236	S229	156	S813HB	89
C139	13	P509	237	S231	157	S814HA	98
C159	10	P511	238	S233	158	S814HB	99
C167	14	P513	239	S260	134	S822	85
C246	40	P515	240	S262	135	S823	91
C247	38	P521	241	S501	154	S902	70
C273	41	P523	242	S511	155	S903	72
C295	43	P601	214	S521	140	S904	74
C299	36	P605	215	S523	141	S922	71
C305	21	P607	216	S524	143	S933	73
C306	17	P609	217	S525	149	S944	75
C346	24	P611	218	S526	150	S991	76
C352	23	P613	219	S527	151		
C353	18	P615	220	S529	160		
C367	20	P621	221	S531	161		
C400	27	P701	204	S533	162		
C407	29	P703	205	S534	163		
C413	28	P705	206	S535	164		
C428	30	P707	207	S536	119		
C492	32	P709	208	S561	144		
C500	47	P711	209	S610	113		
C505	48	P713	210	S611	114		
C700	50	P715	211	S612	138		
C800	52	P721	212	S614	118		
C822	53	P801	182	S629	159		
C830	51	P801C	183	S637	112		
C907	37	P803	184	S638	115		
C908	31	P803C	185	S650	116		
C920	46	P805	186	S654	117		
C922	26	P805C	187	S662	139		
C948	33	P807	188	S710	84		
D		P807C	189	S713	90		
D400	65	P809	190	S714	92		
D402	67	P811	191	S715	93		
D420	66	P811C	192	S716	100		
D745	56	P813	193	S717	101		
D747	58	P813C	194	S718	102		
D750	60	P815	195	S722HB	132		
D751	61	P815C	196	S739	106		
D752	62	P817	197	S740	107		
D753	63	P819	198	S761	128		
D763	64	P821	199	S763	129		
J		P821C	200	S765	110		
J200	168	P823	201	S765HB	111		
J205	169	P825	202	S766	130		
J210	170	P831	224	S767	131		
J215	171	P833	225	S768	133		
J220	172	P835	226	S770HB	122		
J225	173	P837	227	S771HB	123		
J235	174	P841	228	S772HB	124		
J245	175	P842	229	S773HB	125		
J260	176	P843	230	S791	165		
J280	177	P844	231	S802HA	80		
M		P880	244	S802HB	81		
M902	248	P890	245	S803HA	86		
				S803HB	87		



**OUTILS POUR LA FABRICATION DE BASE, L'ENTRETIEN, LA RÉPARATION, LA RÉVISION.
GÉNÉRALEMENT UTILISÉS AVEC DES MACHINES CONVENTIONNELLES.**

Code de matériau du corps (BMC)		HSS-E PM	HSS-E PM	HSS-E	HSS-E PM	HSS-E PM	HSS-E	HSS-E	HSS-E	HSS-E PM	HSS-E PM	HSS-E PM	HSS-E PM	HSS-E	
Profil de fraise		N	N	W	N	N	N	N	N	N	N	N	N	N	
Nombre de goujures (NOF)		NOF 2	NOF 2	NOF 2	NOF 2	NOF 2	NOF 2	NOF 2	NOF 2	NOF 3	NOF 3	NOF 3	NOF 3	NOF 3	
Longueur de coupe															
Angle d'hélice de goujure (FHA)		λ 30°	λ 30°	λ 40°	λ 30°	λ 30°	λ 30°	λ 30°	λ 30°	λ 30°	λ 30°	λ 40°	λ 30°	λ 30°	
Angle d'hélice de goujure (FHA)		λ 30°	λ 30°	λ 40°	λ 30°	λ 30°	λ 30°	λ 30°	λ 30°	λ 30°	λ 30°	λ 40°	λ 30°	λ 30°	
Angle de coupe radial (GAMF)		γ 12°	γ 12°	γ 20°	γ 12°	γ 12°	γ 12°	γ 12°	γ 12°	γ 12°	γ 12°	γ 15°	γ 12°	γ 12°	
Queue															
Revêtement		Bright	TiCN	Bright	Bright	TiCN	Bright	Bright	Bright	Bright	Alcrona	Alcrona	Bright	Alcrona	
Classe de tolérance du diamètre de coupe (TCDC)		DC e8	DC e8	DC e8	DC e8	DC js14	DC e8	DC e8	DC e8	DC e8	DC e8	DC e8	DC e8	DC e8	
Direction de coupe															
Groupe standard de base (BSG)		DIN 327D	DIN 327D	DIN 844K	DIN 844K	DORMER	DORMER	DORMER	DIN 327D	DIN 327D	DIN 327D	DIN 844K	DIN 844K	DIN 844L	
Code de famille de produits		C110	C126	C159	C123	C139	C167	C135	C122	C306	C353	C367	C305	C352	C346
Plage de diamètres de coupe PSF		1.00 – 40.00	1.00 – 25.00	2.00 – 20.00	1/16 – 30.00	2.00 – 22.00	6.00 – 16.00	2.00 – 20.00	5.00 – 22.00	3.00 – 30.00	3.00 – 30.00	2.00 – 20.00	2.00 – 32.00	3.00 – 20.00	3.00 – 20.00
P	P1	■	■	■	■	■	■	■	■	■	■	■	■	■	■
	P2	■	■	■	■	■	■	■	■	■	■	■	■	■	■
	P3	■	■	■	■	■	■	■	■	■	■	■	■	■	■
	P4	■	■	■	■	■	■	■	■	■	■	■	■	■	■
M	M1	■	■	■	■	■	■	■	■	■	■	■	■	■	■
	M2	■	■	■	■	■	■	■	■	■	■	■	■	■	■
	M3	■	■	■	■	■	■	■	■	■	■	■	■	■	■
	M4	■	■	■	■	■	■	■	■	■	■	■	■	■	■
K	K1	■	■	■	■	■	■	■	■	■	■	■	■	■	■
	K2	■	■	■	■	■	■	■	■	■	■	■	■	■	■
	K3	■	■	■	■	■	■	■	■	■	■	■	■	■	■
	K4	■	■	■	■	■	■	■	■	■	■	■	■	■	■
	K5	■	■	■	■	■	■	■	■	■	■	■	■	■	■
N	N1	■	■	■	■	■	■	■	■	■	■	■	■	■	■
	N2	■	■	■	■	■	■	■	■	■	■	■	■	■	■
	N3	■	■	■	■	■	■	■	■	■	■	■	■	■	■
	N4	■	■	■	■	■	■	■	■	■	■	■	■	■	■
	N5	■	■	■	■	■	■	■	■	■	■	■	■	■	■
S	S1	■	■	■	■	■	■	■	■	■	■	■	■	■	■
	S2	■	■	■	■	■	■	■	■	■	■	■	■	■	■
	S3	■	■	■	■	■	■	■	■	■	■	■	■	■	■
	S4	■	■	■	■	■	■	■	■	■	■	■	■	■	■
H	H1														
	H2														
	H3														
	H4														



C110



Fraise à rainurer P9 en HSS-E-PM à 2 dents, série extra-courte, finition brillante

Fraise à 2 dents avec une longueur de coupe extra courte assurant une grande rigidité. Convient pour le fraisage de rainures peu profondes et le ramping. La grande précision du diamètre de coupe permet le fraisage de rainures de clavettes standards avec une tolérance P9. Polyvalente, elle peut être utilisée dans les aciers doux, les matériaux non-ferreux et les alliages de titane de résistance moyenne.

HSS-E PM	N	NOF 2
	λ 30°	γ 12°
	Bright	DC e8
	DIN 327D	

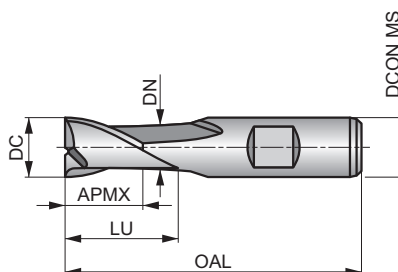

Adéquation du groupe de matériaux de la pièce, valeurs de départ pour la vitesse de coupe (m/min) et code alpha. Tableaux d'avances par dent et facteurs de correction à partir de la page 261.

P1.1 ■ 53 E	P1.2 ■ 59 E	P1.3 ■ 61 E	P2.1 ■ 45 E	P2.2 ■ 40 E	P3.1 ■ 37 E	P3.2 ■ 30 D	P4.1 ■ 22 D	M1.1 ■ 41 E	M1.2 ■ 35 E	M2.1 ■ 37 E	M2.2 ■ 30 D	K1.1 ■ 35 E	K1.2 ■ 26 E
K1.3 ■ 19 E	K2.1 ■ 62 E	K2.2 ■ 50 E	K2.3 ■ 40 D	K3.1 ■ 54 E	K3.2 ■ 42 E	K3.3 ■ 34 D	K4.1 ■ 50 D	K4.2 ■ 38 D	K4.3 ■ 28 D	K4.4 ■ 24 C	K4.5 ■ 20 C	K5.1 ■ 57 D	K5.2 ■ 43 D
K5.3 ■ 33 D	N1.1 ■ 95 G	N1.2 ■ 71 F	N1.3 ■ 48 F	N2.1 ■ 48 E	N2.2 ■ 43 E	N2.3 ■ 31 E	N3.1 ■ 50 E	N3.2 ■ 29 E	N3.3 ■ 15 E	N4.1 ■ 50 E	S1.1 ■ 35 D	S1.2 ■ 25 D	S2.1 ■ 20 C
S3.1 ■ 15 C	S4.1 ■ 12 C												

DCON MS tolérance h6.

Product	DC (inch)	DC (mm)	DCON MS (mm)	APMX (mm)	OAL (mm)	NOF	LU (mm)	DN (mm)
C1101.0	–	1.00	6.00	2.50	47.0	2	–	–
C1101.5	–	1.50	6.00	3.00	47.0	2	–	–
C1101/16	1/16	1.59	6.00	3.00	47.0	2	–	–
C1101.8	–	1.80	6.00	4.00	48.0	2	–	–
C1102.0	–	2.00	6.00	4.00	48.0	2	–	–
C1103/32	3/32	2.38	6.00	5.00	49.0	2	–	–
C1102.5	–	2.50	6.00	5.00	49.0	2	–	–
C1102.8	–	2.80	6.00	5.00	49.0	2	–	–
C1103.0	–	3.00	6.00	5.00	49.0	2	–	–
C1101/8	1/8	3.18	6.00	6.00	50.0	2	–	–
C1103.5	–	3.50	6.00	6.00	50.0	2	–	–
C1103.8	–	3.80	6.00	7.00	51.0	2	–	–
C1104.0	–	4.00	6.00	7.00	51.0	2	–	–
C1104.5	–	4.50	6.00	7.00	51.0	2	–	–
C1103/16	3/16	4.76	6.00	8.00	52.0	2	–	–
C1105.0	–	5.00	6.00	8.00	52.0	2	–	–
C1105.5	–	5.50	6.00	8.00	52.0	2	–	–
C1105.75 ²⁾	–	5.75	6.00	8.00	52.0	2	–	–
C1106.0	–	6.00	6.00	8.00	52.0	2	–	–
C1101/4	1/4	6.35	10.00	10.00	60.0	2	–	–
C1106.5	–	6.50	10.00	10.00	60.0	2	–	–
C1107.0	–	7.00	10.00	10.00	60.0	2	–	–
C1107.5	–	7.50	10.00	10.00	60.0	2	–	–
C1107.75 ²⁾	–	7.75	10.00	11.00	61.0	2	–	–
C1105/16	5/16	7.94	10.00	11.00	61.0	2	–	–



Product	DC	DC	DCON MS	APMX	OAL	NOF	LU	DN
	(inch)	(mm)	(mm)	(mm)	(mm)		(mm)	(mm)
C1108.0	–	8.00	10.00	11.00	61.0	2	–	–
C1108.5	–	8.50	10.00	11.00	61.0	2	–	–
C1109.0	–	9.00	10.00	11.00	61.0	2	–	–
C1109.5	–	9.50	10.00	11.00	61.0	2	–	–
C1103/8	3/8	9.52	10.00	13.00	63.0	2	22.50	9.50
C11010.0	–	10.00	10.00	13.00	63.0	2	22.50	9.50
C11013/32	13/32	10.32	12.00	13.00	70.0	2	–	–
C11010.5	–	10.50	12.00	13.00	70.0	2	–	–
C11011.0	–	11.00	12.00	13.00	70.0	2	–	–
C1107/16	7/16	11.11	12.00	13.00	70.0	2	–	–
C11011.5	–	11.50	12.00	13.00	70.0	2	–	–
C11012.0	–	12.00	12.00	16.00	73.0	2	27.50	11.50
C11012.5	–	12.50	12.00	16.00	73.0	2	27.50	11.50
C1101/2	1/2	12.70	12.00	16.00	73.0	2	27.50	11.50
C11013.0	–	13.00	12.00	16.00	73.0	2	27.50	11.50
C11017/32	17/32	13.49	12.00	16.00	73.0	2	27.50	11.50
C11014.0	–	14.00	12.00	16.00	73.0	2	27.50	11.50
C1109/16	9/16	14.29	12.00	16.00	73.0	2	27.50	11.50
C11015.0	–	15.00	12.00	16.00	73.0	2	27.50	11.50
C1105/8	5/8	15.88	16.00	19.00	79.0	2	30.50	15.50
C11016.0	–	16.00	16.00	19.00	79.0	2	30.50	15.50
C11017.0	–	17.00	16.00	19.00	79.0	2	30.50	15.50
C11011/16	11/16	17.46	16.00	19.00	79.0	2	30.50	15.50
C11018.0	–	18.00	16.00	19.00	79.0	2	30.50	15.50
C11019.0	–	19.00	16.00	19.00	79.0	2	30.50	15.50
C1103/4	3/4	19.05	20.00	22.00	88.0	2	37.50	18.50
C11020.0	–	20.00	20.00	22.00	88.0	2	37.50	19.50
C11022.0	–	22.00	20.00	22.00	88.0	2	37.50	19.50
C1107/8	7/8	22.22	20.00	22.00	88.0	2	37.50	19.50
C11024.0	–	24.00	25.00	26.00	102.0	2	45.50	23.50
C11025.0	–	25.00	25.00	26.00	102.0	2	45.50	24.50
C1101	1"	25.40	25.00	26.00	102.0	2	45.50	24.50
C11026.0	–	26.00	25.00	26.00	102.0	2	45.50	24.50
C11028.0	–	28.00	25.00	26.00	102.0	2	45.50	24.50
C11030.0	–	30.00	25.00	26.00	102.0	2	45.50	24.50
C11032.0	–	32.00	32.00	32.00	112.0	2	51.50	31.50
C11035.0¹⁾	–	35.00	32.00	32.00	112.0	2	51.50	31.50
C11036.0¹⁾	–	36.00	32.00	32.00	112.0	2	51.50	31.50
C11040.0¹⁾	–	40.00	40.00	38.00	130.0	2	59.50	39.00

¹⁾ DC tolérance h10; disponible seulement en HSS-E.

²⁾ DC tolérance h10; rainure non en tolérance P9.

C126



Fraise à rainurer P9 en HSS-E-PM à 2 dents, série extra-courte, revêtement TiCN

Fraise à 2 dents avec une longueur de coupe extra courte assurant une grande rigidité. Convient pour le fraisage de rainures peu profondes et le ramping. La grande précision du diamètre de coupe permet le fraisage de rainures de clavettes standards avec une tolérance P9. Le revêtement TiCN augmente la durée de vie de l'outil et améliore les performances lors du fraisage de matériaux durs et abrasifs.

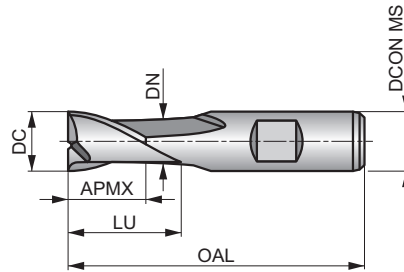

HSS-E PM	N	NOF 2
	λ 30°	γ 12°
DIN 1835B	TiCN	DC e8
	DIN 327D	



Adéquation du groupe de matériaux de la pièce, valeurs de départ pour la vitesse de coupe (m/min) et code alpha. Tableaux d'avances par dent et facteurs de correction à partir de la page 261.

P1.1 ■ 126 E	P1.2 ■ 141 E	P1.3 ■ 146 E	P2.1 ■ 108 E	P2.2 ■ 95 E	P2.3 ▣ 84 D	P3.1 ■ 81 E	P3.2 ■ 65 D	P3.3 ▣ 55 D	P4.1 ■ 48 D	P4.2 ▣ 41 D	P4.3 ▣ 34 D	M1.1 ▣ 62 E	M1.2 ▣ 52 E
M2.1 ▣ 55 E	M2.2 ▣ 45 D	M3.3 ▣ 26 C	M4.1 ▣ 25 C	K1.1 ■ 60 E	K1.2 ■ 44 E	K1.3 ■ 33 E	K2.1 ■ 111 E	K2.2 ■ 90 E	K2.3 ■ 72 D	K3.1 ■ 98 E	K3.2 ■ 75 E	K3.3 ■ 61 D	K4.1 ■ 91 D
K4.2 ■ 68 D	K4.3 ■ 50 D	K4.4 ■ 43 C	K4.5 ■ 36 C	K5.1 ■ 103 D	K5.2 ■ 77 D	K5.3 ■ 60 D	N1.1 ▣ 177 G	N1.2 ▣ 133 F	N1.3 ▣ 89 F	N2.1 ▣ 89 E	N2.2 ■ 80 E	N2.3 ■ 57 E	N3.1 ■ 93 E
N3.2 ■ 55 E	N3.3 ■ 28 E	N4.1 ▣ 93 E	S1.1 ■ 45 D	S1.2 ■ 40 D	S1.3 ▣ 15 C	S2.1 ■ 33 C	S2.2 ▣ 14 C	S3.1 ■ 25 C	S3.2 ▣ 10 C	S4.1 ■ 20 C	S4.2 ▣ 8 C		

DCON MS tolérance h6.

Product	DC (mm)	DCON MS (mm)	APMX (mm)	OAL (mm)	NOF	LU (mm)	DN (mm)
C1261.0	1.00	6.00	2.50	47.0	2	-	-
C1261.5	1.50	6.00	3.00	47.0	2	-	-
C1262.0	2.00	6.00	4.00	48.0	2	-	-
C1262.5	2.50	6.00	5.00	49.0	2	-	-
C1263.0	3.00	6.00	5.00	49.0	2	-	-
C1263.5	3.50	6.00	6.00	50.0	2	-	-
C1264.0	4.00	6.00	7.00	51.0	2	-	-
C1264.5	4.50	6.00	7.00	51.0	2	-	-
C1265.0	5.00	6.00	8.00	52.0	2	-	-
C1265.5	5.50	6.00	8.00	52.0	2	-	-
C1266.0	6.00	6.00	8.00	52.0	2	-	-
C1266.5	6.50	10.00	10.00	60.0	2	-	-
C1267.0	7.00	10.00	10.00	60.0	2	-	-
C1267.5	7.50	10.00	10.00	60.0	2	-	-
C1268.0	8.00	10.00	11.00	61.0	2	-	-
C1268.5	8.50	10.00	11.00	61.0	2	-	-
C1269.0	9.00	10.00	11.00	61.0	2	-	-
C12610.0	10.00	10.00	13.00	63.0	2	22.50	9.50
C12610.5	10.50	12.00	13.00	70.0	2	-	-
C12611.0	11.00	12.00	13.00	70.0	2	-	-
C12611.5	11.50	12.00	13.00	70.0	2	-	-
C12612.0	12.00	12.00	16.00	73.0	2	27.50	11.50
C12612.5	12.50	12.00	16.00	73.0	2	27.50	11.50
C12613.0	13.00	12.00	16.00	73.0	2	27.50	11.50
C12614.0	14.00	12.00	16.00	73.0	2	27.50	11.50



Product	DC	DCON MS	APMX	OAL	NOF	LU	DN
	(mm)	(mm)	(mm)	(mm)		(mm)	(mm)
C12615.0	15.00	12.00	16.00	73.0	2	27.50	11.50
C12616.0	16.00	16.00	19.00	79.0	2	30.50	15.50
C12618.0	18.00	16.00	19.00	79.0	2	30.50	15.50
C12620.0	20.00	20.00	22.00	88.0	2	37.50	19.50
C12622.0	22.00	20.00	22.00	88.0	2	37.50	19.50
C12624.0	24.00	25.00	26.00	102.0	2	45.50	23.50
C12625.0	25.00	25.00	26.00	102.0	2	45.50	24.50

C159

DORMER



Fraise à rainurer P9 en HSS-E à 2 dents, série courte, finition brillante

Fraise à 2 dents avec hélice à 40° et une longueur de coupe courte convenant pour le fraisage de rainures et le fraisage de profil dans les matériaux tendres. La grande précision du diamètre de coupe permet le fraisage de rainures de clavettes standards avec une tolérance P9. Conçue spécialement pour le fraisage dans les matériaux non-ferreux.

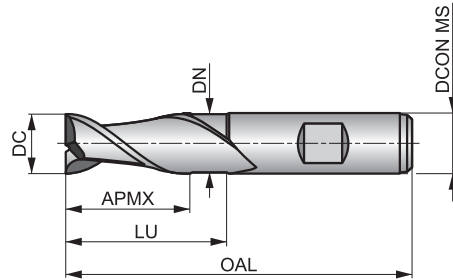

HSS-E	W	NOF 2
	λ 40°	γ 20°
DIN 1835B	Bright	DC e8
	DIN 844K	



Adéquation du groupe de matériaux de la pièce, valeurs de départ pour la vitesse de coupe (m/min) et code alpha. Tableaux d'avances par dent et facteurs de correction à partir de la page 261.

P1.1 ■ 46 D	P1.2 ■ 52 D	P1.3 ■ 54 D	P2.1 ■ 40 D	P2.2 ■ 35 D	M1.1 ■ 32 D	M1.2 ■ 27 D	M2.1 ■ 28 D	M2.2 ■ 23 C	M3.1 ■ 22 C	M3.2 ■ 19 C	N1.1 ■ 142 F	N1.2 ■ 107 E	N1.3 ■ 72 E
N2.1 ■ 72 D	N2.2 ■ 64 D	N2.3 ■ 46 D	N3.1 ■ 75 D	N3.2 ■ 44 D	N3.3 ■ 22 D	N4.1 ■ 75 D	N4.2 ■ 29 D	S1.1 ■ 28 C					

DCON MS tolérance h6.

Product	DC (mm)	DCON MS (mm)	APMX (mm)	OAL (mm)	NOF	LU (mm)	DN (mm)
C1592.0	2.00	6.00	7.00	51.0	2	—	—
C1593.0	3.00	6.00	8.00	52.0	2	—	—
C1594.0	4.00	6.00	11.00	55.0	2	—	—
C1595.0	5.00	6.00	13.00	57.0	2	—	—
C1596.0	6.00	6.00	13.00	57.0	2	—	—
C1598.0	8.00	10.00	19.00	69.0	2	—	—
C15910.0	10.00	10.00	22.00	72.0	2	—	—
C15912.0	12.00	12.00	26.00	83.0	2	—	—
C15914.0	14.00	12.00	26.00	83.0	2	37.50	11.50
C15916.0	16.00	16.00	32.00	92.0	2	43.50	15.50
C15918.0	18.00	16.00	32.00	92.0	2	43.50	15.50
C15920.0	20.00	20.00	38.00	104.0	2	53.50	19.50

C123



Fraise à rainurer P9 en HSS-E-PM à 2 dents, série courte, finition brillante

Fraise à 2 dents avec une longueur de coupe courte assurant une grande rigidité. Convient pour le fraisage de rainures peu profondes et le ramping. La grande précision du diamètre de coupe permet le fraisage de rainures de clavettes standards avec une tolérance P9. Polyvalente, elle peut être utilisée dans les aciers doux, les matériaux non-ferreux et les alliages de titane de résistance moyenne.

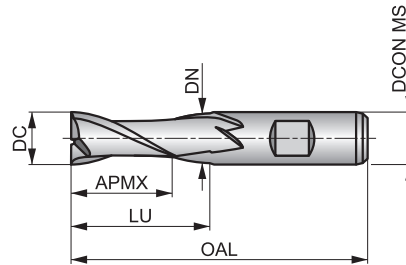

HSS-E PM	N	NOF 2
	λ 30°	γ 12°
DIN 1835B	Bright	DC e8
	DIN 844K	



Adéquation du groupe de matériaux de la pièce, valeurs de départ pour la vitesse de coupe (m/min) et code alpha. Tableaux d'avances par dent et facteurs de correction à partir de la page 261.

P1.1 ■ 53 D	P1.2 ■ 59 D	P1.3 ■ 61 D	P2.1 ■ 45 D	P2.2 ■ 40 D	P3.1 ■ 37 D	P3.2 ■ 30 C	P4.1 ■ 22 C	M1.1 ▣ 34 D	M1.2 ▣ 29 D	M2.1 ▣ 31 D	M2.2 ▣ 25 C	K1.1 ▣ 30 D	K1.2 ▣ 22 D
K1.3 ▣ 17 D	K2.1 ▣ 55 D	K2.2 ▣ 45 D	K2.3 ▣ 36 C	K3.1 ▣ 49 D	K3.2 ▣ 37 D	K3.3 ▣ 30 B	K4.1 ▣ 45 C	K4.2 ▣ 34 C	K4.3 ▣ 25 C	K4.4 ▣ 22 B	K4.5 ▣ 18 B	K5.1 ▣ 51 C	K5.2 ▣ 39 C
K5.3 ▣ 30 C	N1.1 ▣ 95 F	N1.2 ▣ 71 E	N1.3 ▣ 48 E	N2.1 ▣ 48 D	N2.2 ▣ 43 D	N2.3 ▣ 31 D	N3.1 ■ 50 D	N3.2 ■ 29 D	N3.3 ■ 15 D	N4.1 ▣ 50 D	S1.1 ■ 30 C	S1.2 ▣ 25 C	S2.1 ▣ 20 B
S3.1 ▣ 15 B	S4.1 ▣ 12 B												

DCON MS tolérance h6.

Product	DC	DC	DCON MS	APMX	OAL	NOF	LU	DN
	(inch)	(mm)						
C1231/16 ¹⁾	1/16	1.59	6.00	7.00	51.0	2	–	–
C1232.0	–	2.00	6.00	7.00	51.0	2	–	–
C1232.5	–	2.50	6.00	8.00	52.0	2	–	–
C1233.0	–	3.00	6.00	8.00	52.0	2	–	–
C1231/8 ¹⁾	1/8	3.18	6.00	10.00	54.0	2	–	–
C1233.5	–	3.50	6.00	10.00	54.0	2	–	–
C1235/32 ¹⁾	5/32	3.97	6.00	11.00	55.0	2	–	–
C1234.0	–	4.00	6.00	11.00	55.0	2	–	–
C1234.5	–	4.50	6.00	11.00	55.0	2	–	–
C1233/16 ¹⁾	3/16	4.76	6.00	13.00	57.0	2	–	–
C1235.0	–	5.00	6.00	13.00	57.0	2	–	–
C1235.5	–	5.50	6.00	13.00	57.0	2	–	–
C1236.0	–	6.00	6.00	13.00	57.0	2	–	–
C1231/4 ¹⁾	1/4	6.35	10.00	16.00	66.0	2	–	–
C1236.5	–	6.50	10.00	16.00	66.0	2	–	–
C1237.0	–	7.00	10.00	16.00	66.0	2	–	–
C1237.5	–	7.50	10.00	16.00	66.0	2	–	–
C1235/16 ¹⁾	5/16	7.94	10.00	19.00	69.0	2	–	–
C1238.0	–	8.00	10.00	19.00	69.0	2	–	–
C1238.5	–	8.50	10.00	19.00	69.0	2	–	–
C1239.0	–	9.00	10.00	19.00	69.0	2	–	–
C1239.5	–	9.50	10.00	19.00	69.0	2	–	–
C1233/8 ¹⁾	3/8	9.52	10.00	22.00	72.0	2	31.50	9.50
C12310.0	–	10.00	10.00	22.00	72.0	2	31.50	9.50
C12311.0	–	11.00	12.00	22.00	79.0	2	–	–

Product	DC	DC	D CON MS	APMX	OAL	NOF	LU	DN
	(inch)	(mm)	(mm)	(mm)	(mm)		(mm)	(mm)
C12312.0	–	12.00	12.00	26.00	83.0	2	37.50	11.50
C12312 ¹⁾	1/2	12.70	12.00	26.00	83.0	2	37.50	11.50
C12313.0	–	13.00	12.00	26.00	83.0	2	37.50	11.50
C12314.0	–	14.00	12.00	26.00	83.0	2	37.50	11.50
C12315.0	–	15.00	12.00	26.00	83.0	2	37.50	11.50
C12316.0	–	16.00	16.00	32.00	92.0	2	43.50	15.50
C12318.0	–	18.00	16.00	32.00	92.0	2	43.50	15.50
C12320.0	–	20.00	20.00	38.00	104.0	2	53.50	19.50
C12322.0	–	22.00	20.00	38.00	104.0	2	53.50	19.50
C12325.0	–	25.00	25.00	45.00	121.0	2	64.50	24.50
C12330.0	–	30.00	25.00	45.00	121.0	2	64.50	24.50

¹⁾ DC tolérance -0.0005 pouces / -0.0013 pouces.

C139



Fraise à rainurer P9 en HSS-E-PM à 2 dents, série courte, revêtement TiCN

Fraise à 2 dents avec une longueur de coupe courte assurant une grande rigidité. Convient pour le fraisage de rainures peu profondes et le ramping. La grande précision du diamètre de coupe permet le fraisage de rainures de clavettes standards avec une tolérance P9. Le revêtement TiCN augmente la durée de vie de la fraise et améliore les performances lors du fraisage de matériaux durs et abrasifs.

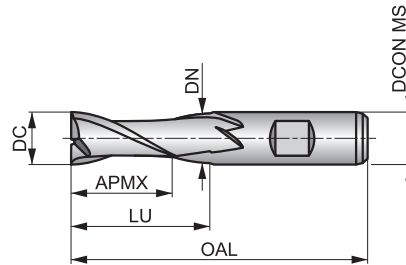

HSS-E PM	N	NOF 2
	λ 30°	γ 12°
DIN 1835B	TiCN	DC e8
	DIN 844K	



Adéquation du groupe de matériaux de la pièce, valeurs de départ pour la vitesse de coupe (m/min) et code alpha. Tableaux d'avances par dent et facteurs de correction à partir de la page 261.

P1.1 ■ 113 D	P1.2 ■ 126 D	P1.3 ■ 131 D	P2.1 ■ 97 D	P2.2 ■ 85 D	P2.3 ▣ 75 C	P3.1 ■ 74 D	P3.2 ■ 59 C	P3.3 ▣ 50 C	P4.1 ■ 44 C	P4.2 ▣ 37 C	P4.3 ▣ 31 C	M1.1 ▣ 62 D	M1.2 ▣ 52 D
M2.1 ▣ 55 D	M2.2 ▣ 45 C	M3.3 ▣ 26 B	M4.1 ▣ 25 B	K1.1 ■ 55 D	K1.2 ■ 41 D	K1.3 ■ 31 D	K2.1 ■ 98 D	K2.2 ■ 80 D	K2.3 ■ 64 C	K3.1 ■ 87 D	K3.2 ■ 67 D	K3.3 ■ 54 B	K4.1 ■ 81 C
K4.2 ■ 61 C	K4.3 ■ 45 C	K4.4 ■ 38 B	K4.5 ■ 32 B	K5.1 ■ 91 C	K5.2 ■ 69 C	K5.3 ■ 53 C	N1.1 ▣ 159 F	N1.2 ▣ 120 E	N1.3 ▣ 80 E	N2.1 ▣ 80 D	N2.2 ▣ 72 D	N2.3 ■ 51 D	N3.1 ■ 84 D
N3.2 ■ 50 D	N3.3 ■ 25 D	N4.1 ▣ 84 D	S1.1 ■ 45 C	S1.2 ■ 35 C	S1.3 ▣ 15 B	S2.1 ■ 33 B	S2.2 ▣ 14 B	S3.1 ■ 25 B	S3.2 ▣ 10 B	S4.1 ■ 20 B	S4.2 ▣ 8 B		

DCON MS tolérance h6.

Product	DC (mm)	DCON MS (mm)	APMX (mm)	OAL (mm)	NOF	LU (mm)	DN (mm)
C1392.0	2.00	6.00	7.00	51.0	2	-	-
C1393.0	3.00	6.00	8.00	52.0	2	-	-
C1394.0	4.00	6.00	11.00	55.0	2	-	-
C1395.0	5.00	6.00	13.00	57.0	2	-	-
C1395.5	5.50	6.00	13.00	57.0	2	-	-
C1396.0	6.00	6.00	13.00	57.0	2	-	-
C1396.5	6.50	10.00	16.00	66.0	2	-	-
C1397.0	7.00	10.00	16.00	66.0	2	-	-
C1397.5	7.50	10.00	16.00	66.0	2	-	-
C1398.0	8.00	10.00	19.00	69.0	2	-	-
C1398.5	8.50	10.00	19.00	69.0	2	-	-
C1399.0	9.00	10.00	19.00	69.0	2	-	-
C13910.0	10.00	10.00	22.00	72.0	2	31.50	9.50
C13911.0	11.00	12.00	22.00	79.0	2	-	-
C13912.0	12.00	12.00	26.00	83.0	2	37.50	11.50
C13913.0	13.00	12.00	26.00	83.0	2	37.50	11.50
C13914.0	14.00	12.00	26.00	83.0	2	37.50	11.50
C13915.0	15.00	12.00	26.00	83.0	2	37.50	11.50
C13916.0	16.00	16.00	32.00	92.0	2	43.50	15.50
C13918.0	18.00	16.00	32.00	92.0	2	43.50	15.50
C13920.0	20.00	20.00	38.00	104.0	2	53.50	19.50
C13922.0	22.00	20.00	38.00	104.0	2	53.50	19.50

C167



Fraise de finition en HSS-E à 2 dents, très longue portée, finition brillante

Fraise à 2 dents avec une longueur de coupe courte et une portée extra longue permettant l'usinage de poches très profondes dans des zones difficiles à atteindre. Convient pour le fraisage des aciers doux et des matériaux non-ferreux.

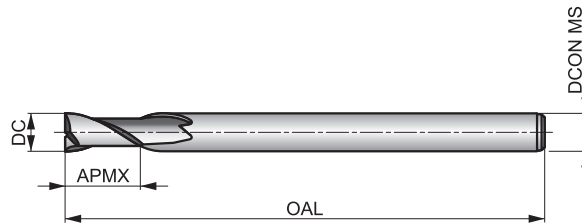

HSS-E	N	NOF 2
	λ 30°	γ 12°
DIN 1835A	Bright	DC js14



Adéquation du groupe de matériaux de la pièce, valeurs de départ pour la vitesse de coupe (m/min) et code alpha. Tableaux d'avances par dent et facteurs de correction à partir de la page 261.

P1.1 ■ 46 C	P1.2 ■ 52 C	P1.3 ■ 54 C	P2.1 ■ 40 C	P2.2 ■ 35 C	P3.1 ■ 32 C	P3.2 ■ 26 B	P4.1 ■ 19 B	M1.1 ■ 34 C	M1.2 ■ 29 C	M2.1 ■ 31 C	M2.2 ■ 25 B	K1.1 ■ 30 C	K1.2 ■ 22 C
K1.3 ■ 17 C	K2.1 ■ 49 C	K2.2 ■ 40 C	K2.3 ■ 32 B	K3.1 ■ 44 C	K3.2 ■ 33 C	K3.3 ■ 27 A	K4.1 ■ 40 B	K4.2 ■ 30 B	K4.3 ■ 22 B	K4.4 ■ 19 A	K4.5 ■ 16 A	K5.1 ■ 46 B	K5.2 ■ 34 B
K5.3 ■ 27 B	N1.1 ■ 81 E	N1.2 ■ 60 D	N1.3 ■ 41 D	N2.1 ■ 41 C	N2.2 ■ 37 C	N2.3 ■ 26 C	N3.1 ■ 43 C	N3.2 ■ 25 C	N3.3 ■ 13 C	N4.1 ■ 43 C	S1.1 ■ 30 B	S1.2 ■ 25 B	S2.1 ■ 20 A
S3.1 ■ 15 A	S4.1 ■ 12 A												

DCON MS tolérance h6.

Product	DC (mm)	DCON MS (mm)	APMX (mm)	OAL (mm)	NOF
C1676.0	6.00	6.00	13.00	180.0	2
C1678.0	8.00	8.00	19.00	180.0	2
C16710.0	10.00	10.00	22.00	200.0	2
C16712.0	12.00	12.00	26.00	200.0	2
C16716.0	16.00	16.00	32.00	200.0	2

C135

DORMER



Fraise à rainurer P9 en HSS-E à 2 dents, très longue portée, finition brillante

Fraise à 2 dents avec une longueur de coupe courte offrant une grande rigidité. La grande précision du diamètre de coupe permet le fraisage de rainures de clavettes standards avec une tolérance P9. Elle offre une résistance accrue et réduit les vibrations dans les zones difficiles à atteindre. Elle peut être utilisée dans les aciers doux et les matériaux non-ferreux.

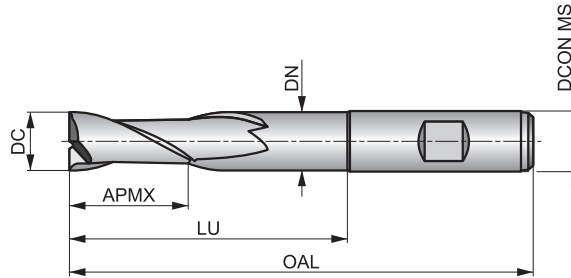

HSS-E	N	NOF 2
	λ 30°	γ 12°
DIN 1835B	Bright	DC e8



Adéquation du groupe de matériaux de la pièce, valeurs de départ pour la vitesse de coupe (m/min) et code alpha. Tableaux d'avances par dent et facteurs de correction à partir de la page 261.

P1.1 ■ 46 C	P1.2 ■ 52 C	P1.3 ■ 54 C	P2.1 ■ 40 C	P2.2 ■ 35 C	P3.1 ■ 32 C	P3.2 ■ 26 B	P4.1 ■ 19 B	M1.1 ■ 34 C	M1.2 ■ 29 C	M2.1 ■ 31 C	M2.2 ■ 25 B	K1.1 ■ 30 C	K1.2 ■ 22 C
K1.3 ■ 17 C	K2.1 ■ 49 C	K2.2 ■ 40 C	K2.3 ■ 32 B	K3.1 ■ 44 C	K3.2 ■ 33 C	K3.3 ■ 27 A	K4.1 ■ 40 B	K4.2 ■ 30 B	K4.3 ■ 22 B	K4.4 ■ 19 A	K4.5 ■ 16 A	K5.1 ■ 46 B	K5.2 ■ 34 B
K5.3 ■ 27 B	N1.1 ■ 81 E	N1.2 ■ 60 D	N1.3 ■ 41 D	N2.1 ■ 41 C	N2.2 ■ 37 C	N2.3 ■ 26 C	N3.1 ■ 43 C	N3.2 ■ 25 C	N3.3 ■ 13 C	N4.1 ■ 43 C	S1.1 ■ 30 B	S1.2 ■ 25 B	S2.1 ■ 20 A
S3.1 ■ 15 A	S4.1 ■ 12 A												

DCON MS tolérance h6.

Product	DC (mm)	DCON MS (mm)	APMX (mm)	OAL (mm)	NOF	LU (mm)	DN (mm)
C1352.0	2.00	6.00	7.00	54.0	2	18.00	1.80
C1353.0	3.00	6.00	8.00	56.0	2	20.00	2.80
C1354.0	4.00	6.00	11.00	63.0	2	27.00	3.70
C1355.0	5.00	6.00	13.00	68.0	2	32.00	4.70
C1356.0	6.00	6.00	13.00	68.0	2	32.00	5.70
C1358.0	8.00	10.00	19.00	88.0	2	48.00	7.50
C13510.0	10.00	10.00	22.00	95.0	2	54.50	9.50
C13512.0	12.00	12.00	26.00	110.0	2	64.50	11.50
C13514.0	14.00	12.00	26.00	110.0	2	64.50	11.50
C13516.0	16.00	16.00	32.00	123.0	2	74.50	15.50
C13518.0	18.00	16.00	32.00	123.0	2	74.50	15.50
C13520.0	20.00	20.00	38.00	141.0	2	90.50	19.50

C122

DORMER



Fraise de finition en HSS-E à 2 dents, série longue, finition brillante

Fraise à 2 dents avec une grande longueur de coupe offrant une grande rigidité pour le fraisage de rainures standards. Convient pour l'usinage de rainures profondes dans des zones difficiles à atteindre, dans les aciers doux et les matériaux non-ferreux.

HSS-E	N	NOF 2
	λ 30°	γ 12°
DIN 1835A	Bright	DC e8
	DORMER	

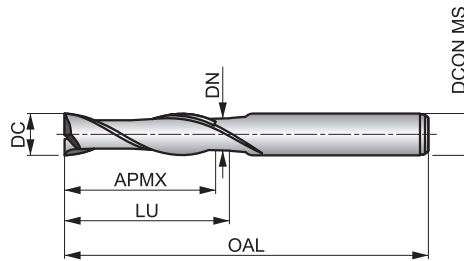

Adéquation du groupe de matériaux de la pièce, valeurs de départ pour la vitesse de coupe (m/min) et code alpha. Tableaux d'avances par dent et facteurs de correction à partir de la page 261.

P1.1 ■ 41 C	P1.2 ■ 46 C	P1.3 ■ 48 C	P2.1 ■ 35 C	P2.2 ▣ 31 C	P3.1 ▣ 28 C	P3.2 ▣ 23 B	P4.1 ▣ 17 B	M1.1 ▣ 27 C	M1.2 ▣ 23 C	M2.1 ▣ 24 C	M2.2 ▣ 20 B	K1.1 ▣ 25 C	K1.2 ▣ 19 C
K1.3 ▣ 14 C	K2.1 ▣ 44 C	K2.2 ▣ 36 C	K2.3 ▣ 29 B	K3.1 ▣ 39 C	K3.2 ▣ 30 C	K3.3 ▣ 24 A	K4.1 ▣ 36 B	K4.2 ▣ 27 B	K4.3 ▣ 20 B	K4.4 ▣ 17 A	K4.5 ▣ 14 A	K5.1 ▣ 41 B	K5.2 ▣ 31 B
K5.3 ▣ 24 B	N1.1 ▣ 76 E	N1.2 ▣ 57 D	N1.3 ▣ 38 D	N2.1 ▣ 38 C	N2.2 ▣ 34 C	N2.3 ▣ 25 C	N3.1 ■ 40 C	N3.2 ■ 23 C	N3.3 ■ 12 C	N4.1 ▣ 40 C	S1.1 ▣ 25 B	S1.2 ▣ 20 B	S2.1 ▣ 15 A
S3.1 ▣ 11 A	S4.1 ▣ 9 A												

DCON MS tolérance h6.

Product	DC (mm)	DCON MS (mm)	APMX (mm)	OAL (mm)	NOF	LU (mm)	DN (mm)
C1225.0	5.00	5.00	22.00	65.0	2	–	–
C1226.0	6.00	6.00	27.00	75.0	2	–	–
C1227.0	7.00	8.00	33.00	85.0	2	–	–
C1228.0	8.00	8.00	33.00	85.0	2	–	–
C12210.0	10.00	10.00	40.00	95.0	2	–	–
C12212.0	12.00	12.00	45.00	110.0	2	–	–
C12214.0	14.00	12.00	52.00	125.0	2	–	–
C12216.0	16.00	16.00	58.00	140.0	2	69.50	15.50
C12218.0	18.00	16.00	65.00	150.0	2	76.50	15.50
C12220.0	20.00	20.00	70.00	160.0	2	85.50	19.50
C12222.0	22.00	20.00	75.00	170.0	2	90.50	19.50

C306



Fraise à rainurer P9 en HSS-E-PM à 3 dents, série extra-courte, finition brillante

Fraise à 3 dents avec une longueur de coupe extra courte offrant une grande rigidité. Convient au fraisage de rainures peu profondes et au ramping. La grande précision du diamètre de coupe permet le fraisage de rainures de clavettes standards avec une tolérance P9. Polyvalente, elle peut être utilisée dans les aciers doux et les matériaux non-ferreux.

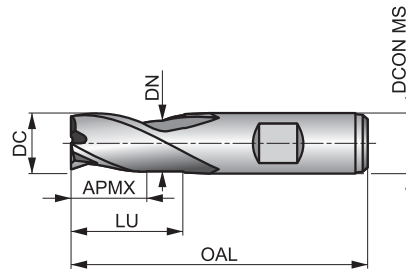

HSS-E PM	N	NOF 3
	λ 30°	γ 12°
DIN 1835B	Bright	DC e8
	DIN 327D	



Adéquation du groupe de matériaux de la pièce, valeurs de départ pour la vitesse de coupe (m/min) et code alpha. Tableaux d'avances par dent et facteurs de correction à partir de la page 261.

P1.1 ■ 54 E	P1.2 ■ 61 E	P1.3 ■ 63 E	P2.1 ■ 47 E	P2.2 ■ 41 E	P3.1 ▣ 38 E	P3.2 ▣ 31 D	P4.1 ▣ 23 D	M1.1 ▣ 36 E	M1.2 ▣ 30 E	M2.1 ▣ 32 E	M2.2 ▣ 26 D	K1.1 ▣ 32 E	K1.2 ▣ 24 E
K1.3 ▣ 18 E	K2.1 ▣ 59 E	K2.2 ▣ 48 E	K2.3 ▣ 38 D	K3.1 ▣ 52 E	K3.2 ▣ 40 E	K3.3 ▣ 32 D	K4.1 ▣ 48 D	K4.2 ▣ 37 D	K4.3 ▣ 27 D	K4.4 ▣ 23 C	K4.5 ▣ 19 C	K5.1 ▣ 55 D	K5.2 ▣ 41 D
K5.3 ▣ 32 D	N1.3 ▣ 50 F	N2.1 ▣ 50 E	N2.2 ▣ 45 E	N2.3 ▣ 32 E	N3.1 ■ 52 E	N3.2 ■ 30 E	N3.3 ■ 16 E	N4.1 ▣ 52 E	S1.1 ■ 33 D	S1.2 ▣ 26 D	S2.1 ▣ 20 C	S3.1 ▣ 15 C	S4.1 ▣ 12 C

DCON MS tolérance h6.

Product	DC (mm)	DCON MS (mm)	APMX (mm)	OAL (mm)	NOF	LU (mm)	DN (mm)
C3063.0	3.00	6.00	5.00	49.0	3	–	–
C3064.0	4.00	6.00	7.00	51.0	3	–	–
C3065.0	5.00	6.00	8.00	52.0	3	–	–
C3066.0	6.00	6.00	8.00	52.0	3	–	–
C3067.0	7.00	10.00	10.00	60.0	3	–	–
C3068.0	8.00	10.00	11.00	61.0	3	–	–
C3069.0	9.00	10.00	11.00	61.0	3	–	–
C30610.0	10.00	10.00	13.00	63.0	3	22.50	9.50
C30611.0	11.00	12.00	13.00	70.0	3	–	–
C30612.0	12.00	12.00	16.00	73.0	3	27.50	11.50
C30614.0	14.00	12.00	16.00	73.0	3	27.50	11.50
C30615.0	15.00	12.00	16.00	73.0	3	27.50	11.50
C30616.0	16.00	16.00	19.00	79.0	3	30.50	15.50
C30618.0	18.00	16.00	19.00	79.0	3	30.50	15.50
C30620.0	20.00	20.00	22.00	88.0	3	37.50	19.50
C30622.0	22.00	20.00	22.00	88.0	3	37.50	19.50
C30625.0	25.00	25.00	26.00	102.0	3	45.50	24.50
C30630.0	30.00	25.00	26.00	102.0	3	45.50	24.50

C353

DORMER



Fraise à rainurer P9 en HSS-E-PM à 3 dents, série extra-courte, revêtement Alcrona

Fraise à 3 dents avec une longueur de coupe extra courte offrant une grande rigidité. Convient au fraisage de rainures peu profondes et au ramping. La grande précision du diamètre de coupe permet le fraisage de rainures de clavettes standards avec une tolérance P9. Le revêtement Alcrona améliore les performances et prolonge la durée de vie de l'outil.

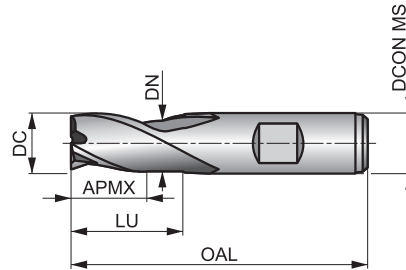

HSS-E PM	N	NOF 3
	λ 30°	γ 12°
DIN 1835B	Alcrona	DC e8
	DIN 327D	



Adéquation du groupe de matériaux de la pièce, valeurs de départ pour la vitesse de coupe (m/min) et code alpha. Tableaux d'avances par dent et facteurs de correction à partir de la page 261.

P1.1 ■ 133 E	P1.2 ■ 148 E	P1.3 ■ 154 E	P2.1 ■ 114 E	P2.2 ■ 100 E	P2.3 ■ 88 D	P3.1 ■ 88 E	P3.2 ■ 71 D	P3.3 ■ 60 D	P4.1 ■ 53 D	P4.2 ■ 45 D	P4.3 ▣ 37 D	M1.1 ▣ 69 E	M1.2 ▣ 58 E
M2.1 ▣ 61 E	M2.2 ▣ 50 D	M3.1 ▣ 52 D	M3.2 ▣ 45 D	M3.3 ▣ 41 C	M4.1 ▣ 30 C	K1.1 ■ 65 E	K1.2 ■ 48 E	K1.3 ■ 36 E	K2.1 ■ 117 E	K2.2 ■ 95 E	K2.3 ■ 76 D	K3.1 ■ 103 E	K3.2 ■ 79 E
K3.3 ■ 64 D	K4.1 ■ 96 D	K4.2 ■ 72 D	K4.3 ■ 53 D	K4.4 ■ 45 C	K4.5 ■ 38 C	K5.1 ■ 108 D	K5.2 ■ 82 D	K5.3 ■ 63 D	N1.3 ▣ 89 F	N2.1 ▣ 89 E	N2.2 ■ 80 E	N2.3 ■ 57 E	N3.1 ■ 93 E
N3.2 ■ 55 E	N3.3 ■ 28 E	N4.1 ▣ 93 E	S1.1 ■ 50 D	S1.2 ■ 40 D	S1.3 ▣ 20 C	S2.1 ■ 40 C	S2.2 ▣ 21 C	S3.1 ■ 30 C	S3.2 ▣ 15 C	S4.1 ■ 23 C	S4.2 ▣ 12 C		

DCON MS tolérance h6.

Product	DC (mm)	DCON MS (mm)	APMX (mm)	OAL (mm)	NOF	LU (mm)	DN (mm)
C3533.0	3.00	6.00	5.00	49.0	3	-	-
C3533.5	3.50	6.00	6.00	50.0	3	-	-
C3534.0	4.00	6.00	7.00	51.0	3	-	-
C3534.5	4.50	6.00	7.00	51.0	3	-	-
C3535.0	5.00	6.00	8.00	52.0	3	-	-
C3535.5	5.50	6.00	8.00	52.0	3	-	-
C3536.0	6.00	6.00	8.00	52.0	3	-	-
C3536.5	6.50	10.00	10.00	60.0	3	-	-
C3537.0	7.00	10.00	10.00	60.0	3	-	-
C3537.5	7.50	10.00	10.00	60.0	3	-	-
C3538.0	8.00	10.00	11.00	61.0	3	-	-
C3538.5	8.50	10.00	11.00	61.0	3	-	-
C3539.0	9.00	10.00	11.00	61.0	3	-	-
C3539.5	9.50	10.00	11.00	61.0	3	-	-
C35310.0	10.00	10.00	13.00	63.0	3	22.50	9.50
C35311.0	11.00	12.00	13.00	70.0	3	-	-
C35312.0	12.00	12.00	16.00	73.0	3	27.50	11.50
C35313.0	13.00	12.00	16.00	73.0	3	27.50	11.50
C35314.0	14.00	12.00	16.00	73.0	3	27.50	11.50
C35315.0	15.00	12.00	16.00	73.0	3	27.50	11.50
C35316.0	16.00	16.00	19.00	79.0	3	30.50	15.50
C35318.0	18.00	16.00	19.00	79.0	3	30.50	15.50
C35320.0	20.00	20.00	22.00	88.0	3	37.50	19.50
C35322.0	22.00	20.00	22.00	88.0	3	37.50	19.50
C35325.0	25.00	25.00	26.00	102.0	3	45.50	24.50



Product	DC	DCON MS	APMX	OAL	NOF	LU	DN
	(mm)	(mm)	(mm)	(mm)		(mm)	(mm)
C35328.0	28.00	25.00	26.00	102.0	3	45.50	24.50
C35330.0	30.00	25.00	26.00	102.0	3	45.50	24.50

C367

DORMER



Fraise à rainurer P9 en HSS-E-PM à 3 dents, série extra-courte, revêtement Alcrona

Fraise à 3 dents avec hélice à 40° et une longueur de coupe extra courte convenant pour usiner les aciers doux, en particulier les aciers inoxydables de moyenne à haute résistance, et les matériaux non-ferreux doux. La grande précision du diamètre de coupe permet le fraisage de rainures de clavettes standards avec une tolérance P9. Le revêtement Alcrona prolonge la durée de vie de l'outil.

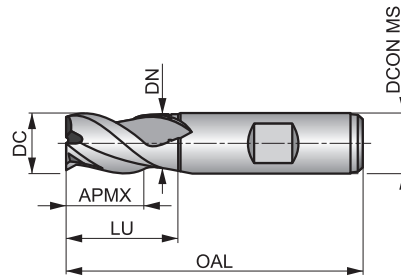

HSS-E PM	N	NOF 3
	λ 40°	γ 15°
DIN 1835B	Alcrona	DC e8
	DIN 327D	



Adéquation du groupe de matériaux de la pièce, valeurs de départ pour la vitesse de coupe (m/min) et code alpha. Tableaux d'avances par dent et facteurs de correction à partir de la page 261.

P1.1 ■ 135 E	P1.2 ■ 151 E	P1.3 ■ 157 E	P2.1 ■ 116 E	P2.2 ■ 102 E	P3.1 ■ 94 E	P3.2 ■ 75 D	P4.1 ■ 56 D	M1.1 ■ 92 E	M1.2 ■ 78 E	M2.1 ■ 82 E	M2.2 ■ 67 D	M2.3 ■ 56 D	M3.1 ■ 64 D
M3.2 ■ 55 D	M3.3 ■ 50 C	M4.1 ■ 35 C	M4.2 ■ 30 C	N1.1 ■ 177 G	N1.2 ■ 133 F	N1.3 ■ 89 F	N2.1 ■ 89 E	N2.2 ■ 180 E	N2.3 ■ 57 E	N3.1 ■ 93 E	N3.2 ■ 55 E	N3.3 ■ 28 E	N4.1 ■ 93 E
S1.1 ■ 50 D													

DCON MS tolérance h6.

Product	DC (mm)	DCON MS (mm)	APMX (mm)	OAL (mm)	NOF	LU (mm)	DN (mm)
C3672.0	2.00	6.00	4.00	48.0	3	—	—
C3673.0	3.00	6.00	5.00	49.0	3	—	—
C3674.0	4.00	6.00	7.00	51.0	3	—	—
C3675.0	5.00	6.00	8.00	52.0	3	—	—
C3676.0	6.00	6.00	8.00	52.0	3	—	—
C3677.0	7.00	10.00	10.00	60.0	3	—	—
C3678.0	8.00	10.00	11.00	61.0	3	—	—
C36710.0	10.00	10.00	13.00	63.0	3	22.50	9.50
C36711.0	11.00	12.00	13.00	70.0	3	—	—
C36712.0	12.00	12.00	16.00	73.0	3	27.50	11.50
C36714.0	14.00	12.00	16.00	73.0	3	27.50	11.50
C36716.0	16.00	16.00	19.00	79.0	3	30.50	15.50
C36718.0	18.00	16.00	19.00	79.0	3	30.50	15.50
C36720.0	20.00	20.00	22.00	88.0	3	37.50	19.50

C305



Fraise à rainurer P9 en HSS-E-PM à 3 dents, série courte, finition brillante

Fraise à 3 dents avec une longueur de coupe courte offrant une grande rigidité pour le fraisage de rainures. La grande précision du diamètre de coupe permet le fraisage de rainures de clavettes standards avec une tolérance P9. Convient également pour le fraisage de rainures et de profils dans les aciers doux, les matériaux non-ferreux et les alliages haute température de résistance moyenne.

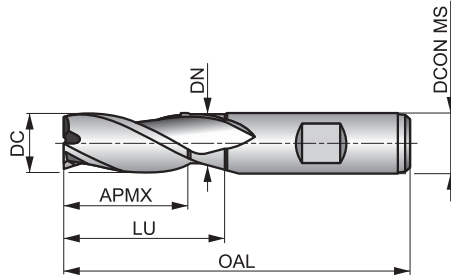

HSS-E PM	N	NOF 3
	λ 30°	γ 12°
DIN 1835B	Bright	DC e8
	DIN 844K	



Adéquation du groupe de matériaux de la pièce, valeurs de départ pour la vitesse de coupe (m/min) et code alpha. Tableaux d'avances par dent et facteurs de correction à partir de la page 261.

P1.1 ■ 52 D	P1.2 ■ 58 D	P1.3 ■ 60 D	P2.1 ■ 44 D	P2.2 ■ 39 D	P3.1 ■ 36 D	P3.2 ■ 29 C	P4.1 ■ 21 C	M1.1 ■ 36 D	M1.2 ■ 30 D	M2.1 ■ 32 D	M2.2 ■ 26 C	K1.1 ■ 30 D	K1.2 ■ 22 D
K1.3 ■ 17 D	K2.1 ■ 55 D	K2.2 ■ 45 D	K2.3 ■ 36 C	K3.1 ■ 49 D	K3.2 ■ 37 D	K3.3 ■ 30 B	K4.1 ■ 45 C	K4.2 ■ 34 C	K4.3 ■ 25 C	K4.4 ■ 22 B	K4.5 ■ 18 B	K5.1 ■ 51 C	K5.2 ■ 39 C
K5.3 ■ 30 C	N1.3 ■ 48 E	N2.1 ■ 48 D	N2.2 ■ 43 D	N2.3 ■ 31 D	N3.1 ■ 50 D	N3.2 ■ 29 D	N3.3 ■ 15 D	N4.1 ■ 50 D	S1.1 ■ 29 C	S1.2 ■ 24 C	S2.1 ■ 17 B	S3.1 ■ 13 B	S4.1 ■ 10 B

DCON MS tolérance h6.

Product	DC (mm)	DCON MS (mm)	APMX (mm)	OAL (mm)	NOF	LU (mm)	DN (mm)
C3052.0	2.00	6.00	7.00	51.0	3	-	-
C3052.5	2.50	6.00	8.00	52.0	3	-	-
C3053.0	3.00	6.00	8.00	52.0	3	-	-
C3053.5	3.50	6.00	10.00	54.0	3	-	-
C3054.0	4.00	6.00	11.00	55.0	3	-	-
C3054.5	4.50	6.00	11.00	55.0	3	-	-
C3055.0	5.00	6.00	13.00	57.0	3	-	-
C3055.5	5.50	6.00	13.00	57.0	3	-	-
C3056.0	6.00	6.00	13.00	57.0	3	-	-
C3056.5	6.50	10.00	16.00	66.0	3	-	-
C3057.0	7.00	10.00	16.00	66.0	3	-	-
C3057.5	7.50	10.00	16.00	66.0	3	-	-
C3058.0	8.00	10.00	19.00	69.0	3	-	-
C3058.5	8.50	10.00	19.00	69.0	3	-	-
C3059.0	9.00	10.00	19.00	69.0	3	-	-
C30510.0	10.00	10.00	22.00	72.0	3	31.50	9.50
C30511.0	11.00	12.00	22.00	79.0	3	-	-
C30512.0	12.00	12.00	26.00	83.0	3	37.50	11.50
C30513.0	13.00	12.00	26.00	83.0	3	37.50	11.50
C30514.0	14.00	12.00	26.00	83.0	3	37.50	11.50
C30515.0	15.00	12.00	26.00	83.0	3	37.50	11.50
C30516.0	16.00	16.00	32.00	92.0	3	43.50	15.50
C30517.0	17.00	16.00	32.00	92.0	3	43.50	15.50
C30518.0	18.00	16.00	32.00	92.0	3	43.50	15.50
C30519.0	19.00	16.00	32.00	92.0	3	43.50	15.50
C30520.0	20.00	20.00	38.00	104.0	3	53.50	19.50
C30522.0	22.00	20.00	38.00	104.0	3	53.50	19.50



Product	DC	DCON MS	APMX	OAL	NOF	LU	DN
	(mm)	(mm)	(mm)	(mm)		(mm)	(mm)
C30525.0	25.00	25.00	45.00	121.0	3	–	–
C30528.0	28.00	25.00	45.00	121.0	3	–	–
C30532.0	32.00	32.00	53.00	133.0	3	–	–

C352

DORMER



Fraise à rainurer P9 en HSS-E-PM à 3 dents, série courte, revêtement Alcrona

Fraise à 3 dents avec une longueur de coupe courte offrant une grande rigidité pour le fraisage de rainures. La grande précision du diamètre de coupe permet le fraisage de rainures de clavettes standards avec une tolérance P9. Convient également pour le rainurage et le fraisage de profil dans les matériaux doux. Le revêtement Alcrona améliore les performances et prolonge la durée de vie de l'outil.

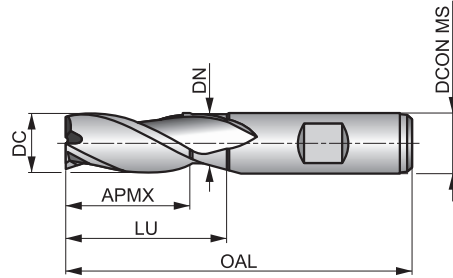

HSS-E PM	N	NOF 3
	λ 30°	γ 12°
DIN 1835B	Alcrona	DC e8
	DIN 844K	



Adéquation du groupe de matériaux de la pièce, valeurs de départ pour la vitesse de coupe (m/min) et code alpha. Tableaux d'avances par dent et facteurs de correction à partir de la page 261.

P1.1 ■ 126 D	P1.2 ■ 141 D	P1.3 ■ 146 D	P2.1 ■ 108 D	P2.2 ■ 95 D	P2.3 ■ 84 C	P3.1 ■ 81 D	P3.2 ■ 65 C	P3.3 ■ 55 C	P4.1 ■ 48 C	P4.2 ■ 41 C	P4.3 ▣ 34 C	M1.1 ▣ 69 D	M1.2 ▣ 58 D
M2.1 ▣ 61 D	M2.2 ▣ 50 C	M3.1 ▣ 47 C	M3.2 ▣ 40 C	M3.3 ▣ 36 B	M4.1 ▣ 25 B	K1.1 ■ 60 D	K1.2 ■ 44 D	K1.3 ■ 33 D	K2.1 ■ 111 D	K2.2 ■ 90 D	K2.3 ■ 72 C	K3.1 ■ 98 D	K3.2 ■ 75 D
K3.3 ■ 61 B	K4.1 ■ 91 C	K4.2 ■ 68 C	K4.3 ■ 50 C	K4.4 ■ 43 B	K4.5 ■ 36 B	K5.1 ■ 103 C	K5.2 ■ 77 C	K5.3 ■ 60 C	N1.3 ▣ 89 E	N2.1 ▣ 89 D	N2.2 ■ 80 D	N2.3 ■ 57 D	N3.1 ■ 93 D
N3.2 ■ 55 D	N3.3 ■ 28 D	N4.1 ▣ 93 D	S1.1 ■ 45 C	S1.2 ■ 35 C	S1.3 ▣ 15 B	S2.1 ■ 33 B	S2.2 ▣ 14 B	S3.1 ■ 25 B	S3.2 ▣ 10 B	S4.1 ■ 20 B	S4.2 ▣ 8 B		

DCON MS tolérance h6.

Product	DC (mm)	DCON MS (mm)	APMX (mm)	OAL (mm)	NOF	LU (mm)	DN (mm)
C3523.0	3.00	6.00	8.00	52.0	3	–	–
C3524.0	4.00	6.00	11.00	55.0	3	–	–
C3525.0	5.00	6.00	13.00	57.0	3	–	–
C3526.0	6.00	6.00	13.00	57.0	3	–	–
C3528.0	8.00	10.00	19.00	69.0	3	–	–
C35210.0	10.00	10.00	22.00	72.0	3	31.50	9.50
C35212.0	12.00	12.00	26.00	83.0	3	37.50	11.50
C35214.0	14.00	12.00	26.00	83.0	3	37.50	11.50
C35216.0	16.00	16.00	32.00	92.0	3	43.50	15.50
C35218.0	18.00	16.00	32.00	92.0	3	43.50	15.50
C35220.0	20.00	20.00	38.00	104.0	3	53.50	19.50

C346



Fraise de finition en HSS-E à 3 dents, série longue, finition brillante

Fraise à 3 dents avec une grande longueur de coupe offrant une grande rigidité pour le rainurage standard et le fraisage de profil dans les aciers doux et les matériaux non-ferreux. La fraise série longue est conçue pour l'usinage de rainures et de parois plus profondes dans des endroits difficiles à atteindre.

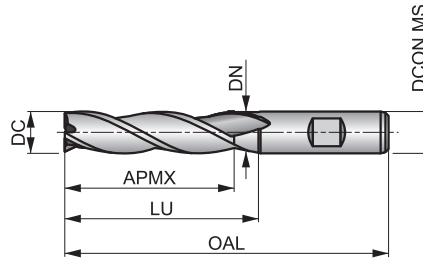

HSS-E	N	NOF 3
	λ 30°	γ 12°
DIN 1835B	Bright	DC e8
	DIN 844L	



Adéquation du groupe de matériaux de la pièce, valeurs de départ pour la vitesse de coupe (m/min) et code alpha. Tableaux d'avances par dent et facteurs de correction à partir de la page 261.

P1.1 ■ 40 C	P1.2 ■ 45 C	P1.3 ■ 46 C	P2.1 ■ 34 C	P2.2 ■ 30 C	P3.1 ■ 28 C	P3.2 ■ 22 B	P4.1 ■ 16 B	M1.1 ■ 27 C	M1.2 ■ 23 C	M2.1 ■ 24 C	M2.2 ■ 20 B	K1.1 ■ 25 C	K1.2 ■ 19 C
K1.3 ■ 14 C	K2.1 ■ 43 C	K2.2 ■ 35 C	K2.3 ■ 28 B	K3.1 ■ 38 C	K3.2 ■ 29 C	K3.3 ■ 24 A	K4.1 ■ 35 B	K4.2 ■ 27 B	K4.3 ■ 20 B	K4.4 ■ 17 A	K4.5 ■ 14 A	K5.1 ■ 40 B	K5.2 ■ 30 B
K5.3 ■ 23 B	N1.1 ■ 76 E	N1.2 ■ 57 D	N1.3 ■ 38 D	N3.1 ■ 40 C	N3.2 ■ 23 C	N3.3 ■ 12 C	N4.1 ■ 40 C	S1.1 ■ 25 B	S1.2 ■ 20 B	S2.1 ■ 13 A	S3.1 ■ 10 A	S4.1 ■ 8 A	

DCON MS tolérance h6.

Product	DC (mm)	DCON MS (mm)	APMX (mm)	OAL (mm)	NOF	LU (mm)	DN (mm)
C3463.0	3.00	6.00	12.00	56.0	3	—	—
C3464.0	4.00	6.00	19.00	63.0	3	—	—
C3465.0	5.00	6.00	24.00	68.0	3	—	—
C3466.0	6.00	6.00	24.00	68.0	3	—	—
C3467.0	7.00	10.00	30.00	80.0	3	—	—
C3468.0	8.00	10.00	38.00	88.0	3	—	—
C3469.0	9.00	10.00	38.00	88.0	3	—	—
C34610.0	10.00	10.00	45.00	95.0	3	—	—
C34611.0	11.00	12.00	45.00	102.0	3	—	—
C34612.0	12.00	12.00	53.00	110.0	3	—	—
C34613.0	13.00	12.00	53.00	110.0	3	64.50	11.50
C34615.0	15.00	12.00	53.00	110.0	3	64.50	11.50
C34616.0	16.00	16.00	63.00	123.0	3	74.50	15.50
C34620.0	20.00	20.00	75.00	141.0	3	90.50	19.50

Code de matériau du corps (BMC)	HSS-E PM	HSS-E	HSS-E	HSS-E PM	HSS-E PM	HSS-E PM	HSS-E PM	HSS-E PM						
Profil de fraise	HRA	NF	NF	NRA	HRA	NRA	HRA	NRA						
Nombre de goujures (NOF)	NOF 3-4	NOF 4	NOF 4	NOF 4	NOF 4-6	NOF 4-6	NOF 3-6	NOF 4-6						
Longueur de coupe														
Angle d'hélice de goujure (FHA)	λ 35°	λ 30°	λ 30°	λ 35°	λ 35°	λ 35°	λ 35°	λ 35°						
Angle d'hélice de goujure (FHA)	λ 35°	λ 30°	λ 30°	λ 35°	λ 35°	λ 35°	λ 35°	λ 35°						
Angle de coupe radial (GAMF)	γ 12°	γ 12°	γ 12°	γ 12°	γ 12°	γ 12°	γ 12°	γ 12°						
Queue														
Revêtement	Alcrona	Bright	TiCN	Bright	Alcrona	Alcrona	Alcrona	Alcrona						
Classe de tolérance du diamètre de coupe (TCDC)	DC k12	DC k12	DC k12	DC k12	DC k12	DC k12	DC k12	DC k12						
Direction de coupe														
Groupe standard de base (BSG)	DIN 844K	DIN 844K	DIN 844K	DIN 844K	DIN 844K	DIN 844K	DIN 844L	DIN 844L						
Code de famille de produits	C922	C400	C413	C407	C428	C908	C492	C948						
Plage de diamètres de coupe PSF	6.00 – 24.00	6.00 – 20.00	6.00 – 20.00	6.00 – 20.00	6.00 – 32.00	6.00 – 32.00	6.00 – 30.00	6.00 – 32.00						
	26	27	28	29	30	31	32	33						
P	P1	■	■	■	■	■	■	■						
	P2	▣	■	■	■	▣	■	■						
	P3	■	▣	■	■	■	■	■						
	P4	■	▣	▣	■	■	■	■						
M	M1	■	▣	▣	■	■	■	■						
	M2	■	▣	▣	■	■	■	■						
	M3	■	■	▣	▣	■	■	■						
	M4	■	■	▣	■	■	■	■						
K	K1	■	▣	■	■	■	■	■						
	K2	■	▣	■	■	■	■	■						
	K3	■	▣	■	■	■	■	■						
	K4	■	▣	■	■	■	■	■						
	K5	■	▣	■	■	■	■	■						
N	N1		▣	▣										
	N2		▣	▣										
	N3	■	■	■	■	■	■	■						
	N4		▣	▣										
	N5													
S	S1	■	▣	▣	■	■	■	■						
	S2	■	▣	▣	■	■	■	■						
	S3	■	▣	▣	■	■	■	■						
	S4	■	▣	▣	■	■	■	■						
H	H1													
	H2													
	H3													
	H4													

C922

DORMER



Fraise d'ébauche en HSS-E-PM à 3-4 dents, série courte, revêtement Alcrona

Fraise à 3 ou 4 dents avec une longueur de coupe courte et un profil HRA fragmentant les copeaux pour une application d'ébauche efficace. Une hélice à 35° réduit les vibrations et améliore les performances. Queue détalonnée sur les diamètres de coupe importants. Le revêtement Alcrona améliore les performances et prolonge la durée de vie de l'outil.

HSS-E PM	HRA	NOF 3-4
	λ 35°	γ 12°
DIN 1835B	Alcrona	DC k12
	DIN 844K	

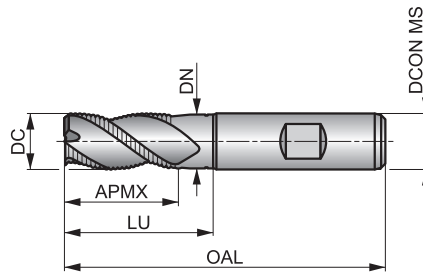

Adéquation du groupe de matériaux de la pièce, valeurs de départ pour la vitesse de coupe (m/min) et code alpha. Tableaux d'avances par dent et facteurs de correction à partir de la page 261.

P2.2 ■ 95 F	P2.3 ■ 84 E	P3.1 ■ 81 F	P3.2 ■ 65 E	P3.3 ■ 55 E	P4.1 ■ 48 E	P4.2 ■ 41 E	P4.3 ■ 34 E	M1.1 ■ 69 F	M1.2 ■ 58 F	M2.1 ■ 61 F	M2.2 ■ 50 E	M3.1 ■ 47 E	M3.2 ■ 40 E
M3.3 ■ 36 D	M4.1 ■ 25 D	K1.1 ■ 60 F	K1.2 ■ 44 F	K1.3 ■ 33 F	K2.1 ■ 111 F	K2.2 ■ 90 F	K2.3 ■ 72 E	K3.1 ■ 98 F	K3.2 ■ 75 F	K3.3 ■ 61 E	K4.1 ■ 91 E	K4.2 ■ 68 E	K4.3 ■ 50 E
K4.4 ■ 43 D	K4.5 ■ 36 D	K5.1 ■ 103 E	K5.2 ■ 77 E	K5.3 ■ 60 E	N3.1 ■ 93 F	N3.2 ■ 55 F	S1.1 ■ 45 E	S1.2 ■ 35 E	S1.3 ■ 15 D	S2.1 ■ 33 D	S2.2 ■ 14 D	S3.1 ■ 25 D	S3.2 ■ 10 D
S4.1 ■ 20 D	S4.2 ■ 8 D												

DCON MS tolérance h6.

Product	DC (mm)	DCON MS (mm)	APMX (mm)	OAL (mm)	NOF	LU (mm)	DN (mm)
C9226.0	6.00	6.00	13.00	57.0	3	-	-
C9227.0	7.00	10.00	16.00	66.0	3	-	-
C9228.0	8.00	10.00	19.00	69.0	3	-	-
C9229.0	9.00	10.00	19.00	69.0	3	-	-
C92210.0	10.00	10.00	22.00	72.0	3	31.50	9.50
C92211.0	11.00	12.00	22.00	79.0	3	-	-
C92212.0	12.00	12.00	26.00	83.0	3	37.50	11.50
C92213.0	13.00	12.00	26.00	83.0	3	37.50	11.50
C92214.0	14.00	12.00	26.00	83.0	3	37.50	11.50
C92215.0	15.00	12.00	26.00	83.0	3	37.50	11.50
C92216.0	16.00	16.00	32.00	92.0	3	43.50	15.50
C92218.0	18.00	16.00	32.00	92.0	3	43.50	15.50
C92220.0	20.00	20.00	38.00	104.0	3	53.50	19.50
C92222.0	22.00	20.00	38.00	104.0	3	53.50	19.50
C92224.0	24.00	25.00	45.00	121.0	4	64.50	23.50

C400



Fraise d'ébauche en HSS-E à 4 dents, série courte, finition brillante

Fraise à 4 dents sans coupe au centre avec une longueur de coupe courte convenant uniquement pour les opérations d'ébauche périphérique. Le profil NF brise les copeaux pour une opération d'ébauche efficace. Une hélice à 30° réduit les vibrations et améliore les performances lors de l'ébauche de matériaux doux.

HSS-E	NF	NOF 4
	λ 30°	γ 12°
DIN 1835B	Bright	DC k12
	DIN 844K	

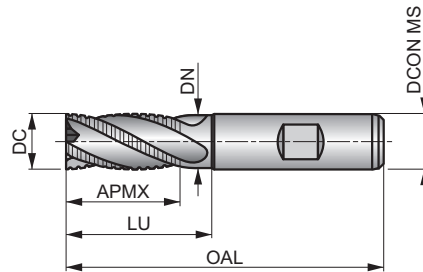

Adéquation du groupe de matériaux de la pièce, valeurs de départ pour la vitesse de coupe (m/min) et code alpha. Tableaux d'avances par dent et facteurs de correction à partir de la page 261.

P1.1 ■ 46 E	P1.2 ■ 52 E	P1.3 ■ 54 E	P2.1 ■ 40 E	P2.2 ■ 35 E	P3.1 ▣ 32 E	P3.2 ▣ 26 D	P4.1 ▣ 19 D	M1.1 ▣ 34 E	M1.2 ▣ 29 E	M2.1 ▣ 31 E	M2.2 ▣ 25 D	K1.1 ▣ 30 E	K1.2 ▣ 22 E
K1.3 ▣ 17 E	K2.1 ▣ 49 E	K2.2 ▣ 40 E	K2.3 ▣ 32 D	K3.1 ▣ 44 E	K3.2 ▣ 33 E	K3.3 ▣ 27 D	K4.1 ▣ 40 D	K4.2 ▣ 30 D	K4.3 ▣ 22 D	K4.4 ▣ 19 C	K4.5 ▣ 16 C	K5.1 ▣ 46 D	K5.2 ▣ 34 D
K5.3 ▣ 27 D	N1.3 ▣ 41 F	N2.1 ▣ 41 E	N2.2 ▣ 37 E	N2.3 ▣ 26 E	N3.1 ■ 43 E	N3.2 ■ 25 E	N3.3 ▣ 13 E	N4.1 ▣ 43 E	S1.1 ▣ 30 D	S1.2 ▣ 25 D	S2.1 ▣ 20 C	S3.1 ▣ 15 C	S4.1 ▣ 12 C

DCON MS tolérance h6.

Product	DC (mm)	DCON MS (mm)	APMX (mm)	OAL (mm)	NOF	LU (mm)	DN (mm)
C4006.0	6.00	6.00	13.00	57.0	4	–	–
C4008.0	8.00	10.00	19.00	69.0	4	–	–
C40010.0	10.00	10.00	22.00	72.0	4	–	–
C40012.0	12.00	12.00	26.00	83.0	4	–	–
C40014.0	14.00	12.00	26.00	83.0	4	37.50	11.50
C40016.0	16.00	16.00	32.00	92.0	4	43.50	15.50
C40018.0	18.00	16.00	32.00	92.0	4	43.50	15.50
C40020.0	20.00	20.00	38.00	104.0	4	53.50	19.50

C413

DORMER



Fraise d'ébauche en HSS-E à 4 dents, série courte, revêtement TiCN

Fraise à 4 dents avec une longueur de coupe courte convenant uniquement aux opérations d'ébauche périphérique. Le profil NF brise les copeaux pour une application d'ébauche efficace. Une hélice à 30° réduit les vibrations et améliore les performances en ébauche. Le revêtement TiCN augmente la durée de vie de la fraise et améliore les performances lors du fraisage de matériaux durs et abrasifs.

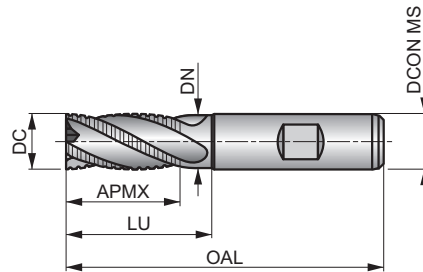

HSS-E	NF	NOF 4
	λ 30°	γ 12°
DIN 1835B	TiCN	DC k12
	DIN 844K	



Adéquation du groupe de matériaux de la pièce, valeurs de départ pour la vitesse de coupe (m/min) et code alpha. Tableaux d'avances par dent et facteurs de correction à partir de la page 261.

P1.1 ■ 93 E	P1.2 ■ 104 E	P1.3 ■ 108 E	P2.1 ■ 80 E	P2.2 ■ 70 E	P2.3 ▣ 62 D	P3.1 ■ 59 E	P3.2 ■ 47 D	P3.3 ▣ 40 D	P4.1 ■ 35 D	P4.2 ▣ 30 D	P4.3 ▣ 24 D	M1.1 ▣ 48 E	M1.2 ▣ 41 E
M2.1 ▣ 43 E	M2.2 ▣ 35 D	M3.3 ▣ 21 C	M4.1 ▣ 20 C	K1.1 ■ 45 E	K1.2 ■ 33 E	K1.3 ■ 25 E	K2.1 ■ 80 E	K2.2 ■ 65 E	K2.3 ■ 52 D	K3.1 ■ 71 E	K3.2 ■ 54 E	K3.3 ■ 44 D	K4.1 ■ 66 D
K4.2 ■ 49 D	K4.3 ■ 36 D	K4.4 ■ 31 C	K4.5 ■ 26 C	K5.1 ■ 74 D	K5.2 ■ 56 D	K5.3 ■ 43 D	N1.3 ▣ 82 F	N2.1 ▣ 182 E	N2.2 ■ 74 E	N2.3 ■ 52 E	N3.1 ■ 86 E	N3.2 ■ 50 E	N3.3 ▣ 126 E
N4.1 ▣ 86 E	S1.1 ▣ 35 D	S1.2 ■ 30 D	S1.3 ▣ 10 C	S2.1 ■ 27 C	S2.2 ▣ 14 C	S3.1 ■ 20 C	S3.2 ▣ 10 C	S4.1 ■ 16 C	S4.2 ▣ 8 C				

DCON MS tolérance h6.

Product	DC (mm)	DCON MS (mm)	APMX (mm)	OAL (mm)	NOF	LU (mm)	DN (mm)
C4136.0	6.00	6.00	13.00	57.0	4	–	–
C4138.0	8.00	10.00	19.00	69.0	4	–	–
C41310.0	10.00	10.00	22.00	72.0	4	–	–
C41312.0	12.00	12.00	26.00	83.0	4	–	–
C41314.0	14.00	12.00	26.00	83.0	4	37.50	11.50
C41316.0	16.00	16.00	32.00	92.0	4	43.50	15.50
C41318.0	18.00	16.00	32.00	92.0	4	43.50	15.50
C41320.0	20.00	20.00	38.00	104.0	4	53.50	19.50

C407

DORMER



Fraise d'ébauche en HSS-E-PM à 4 dents, série courte, finition brillante

Fraise à 4 dents avec une longueur de coupe courte et un profil NRA brisant les copeaux pour des applications d'ébauche efficaces. Une hélice à 35° réduit les vibrations et améliore les performances dans les opérations d'ébauche. Détalonnage arrière sur les gros diamètres de coupe.

HSS-E PM	NRA	NOF 4
	λ 35°	γ 12°
DIN 1835B	Bright	DC k12
	DIN 844K	

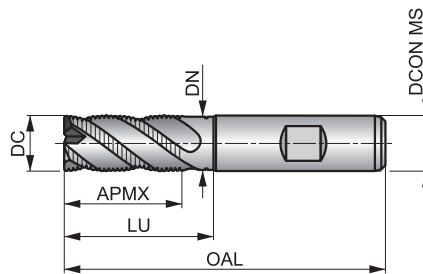

Adéquation du groupe de matériaux de la pièce, valeurs de départ pour la vitesse de coupe (m/min) et code alpha. Tableaux d'avances par dent et facteurs de correction à partir de la page 261.

P1.1 ■ 50 G	P1.2 ■ 56 G	P1.3 ■ 58 G	P2.1 ■ 43 G	P2.2 ■ 38 G	P2.3 ■ 34 F	P3.1 ■ 32 G	P3.2 ■ 26 F	P3.3 ■ 22 F	P4.1 ■ 19 F	P4.2 ■ 16 F	P4.3 ■ 13 F	M1.1 ■ 34 G	M1.2 ■ 29 G
M2.1 ■ 31 G	M2.2 ■ 25 F	M3.1 ■ 24 F	M3.2 ■ 21 F	M3.3 ■ 19 E	M4.1 ■ 13 E	K1.1 ■ 30 G	K1.2 ■ 22 G	K1.3 ■ 17 G	K2.1 ■ 54 G	K2.2 ■ 44 G	K2.3 ■ 35 F	K3.1 ■ 48 G	K3.2 ■ 37 G
K3.3 ■ 30 F	K4.1 ■ 44 F	K4.2 ■ 33 F	K4.3 ■ 25 F	K4.4 ■ 21 E	K4.5 ■ 18 E	K5.1 ■ 50 F	K5.2 ■ 38 F	K5.3 ■ 29 F	N3.1 ■ 43 G	N3.2 ■ 25 G	S1.1 ■ 30 F	S1.2 ■ 25 F	S1.3 ■ 11 E
S2.1 ■ 19 E	S2.2 ■ 8 E	S3.1 ■ 14 E	S3.2 ■ 6 E	S4.1 ■ 11 E	S4.2 ■ 5 E								

DCON MS tolérance h6.

Product	DC (mm)	DCON MS (mm)	APMX (mm)	OAL (mm)	NOF	LU (mm)	DN (mm)
C4076.0	6.00	6.00	13.00	57.0	4	–	–
C4077.0	7.00	10.00	16.00	66.0	4	–	–
C4078.0	8.00	10.00	19.00	69.0	4	–	–
C4079.0	9.00	10.00	19.00	69.0	4	–	–
C40710.0	10.00	10.00	22.00	72.0	4	31.50	9.50
C40711.0	11.00	12.00	22.00	79.0	4	–	–
C40712.0	12.00	12.00	26.00	83.0	4	37.50	11.50
C40713.0	13.00	12.00	26.00	83.0	4	37.50	11.50
C40714.0	14.00	12.00	26.00	83.0	4	37.50	11.50
C40716.0	16.00	16.00	32.00	92.0	4	43.50	15.50
C40718.0	18.00	16.00	32.00	92.0	4	43.50	15.50
C40720.0	20.00	20.00	38.00	104.0	4	53.50	19.50

C428



Fraise d'ébauche en HSS-E-PM à 4 ou 6 dents, série courte, revêtement Alcrona

Fraise à 4 ou 6 dents avec une longueur de coupe courte et un profil HRA brisant les copeaux pour une application d'ébauche efficace. Une hélice à 35° réduit les vibrations et améliore les performances. Détalonnage arrière sur les diamètres de coupe importants. Le revêtement Alcrona améliore les performances et prolonge la durée de vie de l'outil.

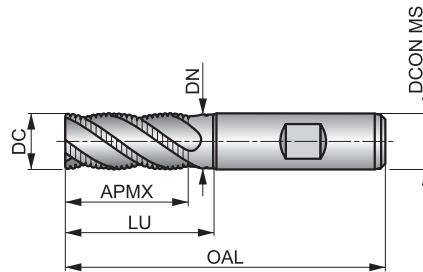

HSS-E PM	HRA	NOF 4-6
	λ 35°	γ 12°
DIN 1835B	Alcrona	DC k12
	DIN 844K	



Adéquation du groupe de matériaux de la pièce, valeurs de départ pour la vitesse de coupe (m/min) et code alpha. Tableaux d'avances par dent et facteurs de correction à partir de la page 261.

P2.2 ■ 93 F	P2.3 ■ 82 E	P3.1 ■ 80 F	P3.2 ■ 64 E	P3.3 ■ 54 E	P4.1 ■ 48 E	P4.2 ■ 40 E	P4.3 ■ 33 E	M1.1 ■ 66 F	M1.2 ■ 56 F	M2.1 ■ 59 F	M2.2 ■ 48 E	M3.1 ■ 47 E	M3.2 ■ 40 E
M3.3 ■ 36 D	M4.1 ■ 26 D	K1.1 ■ 61 F	K1.2 ■ 45 F	K1.3 ■ 34 F	K2.1 ■ 108 F	K2.2 ■ 88 F	K2.3 ■ 70 E	K3.1 ■ 96 F	K3.2 ■ 73 F	K3.3 ■ 59 E	K4.1 ■ 89 E	K4.2 ■ 67 E	K4.3 ■ 49 E
K4.4 ■ 42 D	K4.5 ■ 35 D	K5.1 ■ 100 E	K5.2 ■ 76 E	K5.3 ■ 58 E	N3.1 ■ 116 F	N3.2 ■ 68 F	S1.1 ■ 46 E	S1.2 ■ 37 E	S1.3 ■ 16 D	S2.1 ■ 36 D	S2.2 ■ 16 D	S3.1 ■ 27 D	S3.2 ■ 11 D
S4.1 ■ 21 D	S4.2 ■ 9 D												

DCON MS tolérance h6.

Product	DC (mm)	DCON MS (mm)	APMX (mm)	OAL (mm)	NOF	LU (mm)	DN (mm)
C4286.0	6.00	6.00	13.00	57.0	4	–	–
C4287.0	7.00	10.00	16.00	66.0	4	–	–
C4288.0	8.00	10.00	19.00	69.0	4	–	–
C4289.0	9.00	10.00	19.00	69.0	4	–	–
C42810.0	10.00	10.00	22.00	72.0	4	31.50	9.50
C42811.0	11.00	12.00	22.00	79.0	4	–	–
C42812.0	12.00	12.00	26.00	83.0	4	37.50	11.50
C42813.0	13.00	12.00	26.00	83.0	4	37.50	11.50
C42814.0	14.00	12.00	26.00	83.0	4	37.50	11.50
C42815.0	15.00	12.00	26.00	83.0	4	37.50	11.50
C42816.0	16.00	16.00	32.00	92.0	4	43.50	15.50
C42818.0	18.00	16.00	32.00	92.0	4	43.50	15.50
C42820.0	20.00	20.00	38.00	104.0	4	53.50	19.50
C42822.0	22.00	20.00	38.00	104.0	4	53.50	19.50
C42825.0	25.00	25.00	45.00	121.0	6	64.50	24.50
C42828.0	28.00	25.00	45.00	121.0	6	64.50	24.50
C42830.0	30.00	25.00	45.00	121.0	6	64.50	24.50
C42832.0	32.00	32.00	53.00	133.0	6	72.50	31.50

C908



Fraise d'ébauche en HSS-E-PM à 4 ou 6 dents, série courte, revêtement Alcrona

Fraise à 4 ou 6 dents avec une longueur de coupe courte et un profil NRA brisant les copeaux pour une application d'ébauche efficace. Une hélice à 35° réduit les vibrations et améliore les performances en ébauche. Détalonnage arrière sur les gros diamètres de coupe. Le revêtement Alcrona améliore les performances et prolonge la durée de vie de l'outil.

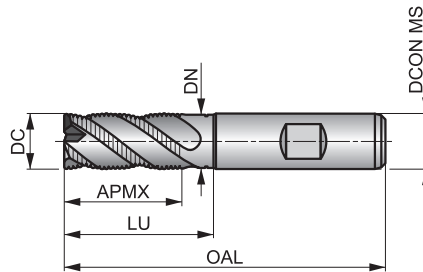

HSS-E PM	NRA	NOF 4-6
	λ 35°	γ 12°
DIN 1835B	Alcrona	DC k12
	DIN 844K	



Adéquation du groupe de matériaux de la pièce, valeurs de départ pour la vitesse de coupe (m/min) et code alpha. Tableaux d'avances par dent et facteurs de correction à partir de la page 261.

P2.2 ■ 93 G	P2.3 ■ 82 F	P3.1 ■ 80 G	P3.2 ■ 64 F	P3.3 ■ 54 F	P4.1 ■ 48 F	P4.2 ■ 40 F	P4.3 ■ 33 F	M1.1 ■ 66 G	M1.2 ■ 56 G	M2.1 ■ 59 G	M2.2 ■ 48 F	M3.1 ■ 47 F	M3.2 ■ 40 F
M3.3 ■ 36 E	M4.1 ■ 26 E	K1.1 ■ 61 G	K1.2 ■ 45 G	K1.3 ■ 34 G	K2.1 ■ 108 G	K2.2 ■ 88 G	K2.3 ■ 70 F	K3.1 ■ 96 G	K3.2 ■ 73 G	K3.3 ■ 59 F	K4.1 ■ 89 F	K4.2 ■ 67 F	K4.3 ■ 49 F
K4.4 ■ 42 E	K4.5 ■ 35 E	K5.1 ■ 100 F	K5.2 ■ 76 F	K5.3 ■ 58 F	N3.1 ■ 93 G	N3.2 ■ 55 G	S1.1 ■ 46 F	S1.2 ■ 37 F	S1.3 ■ 16 E	S2.1 ■ 36 E	S2.2 ■ 16 E	S3.1 ■ 27 E	S3.2 ■ 11 E
S4.1 ■ 21 E	S4.2 ■ 9 E												

DCON MS tolérance h6.

Product	DC (mm)	DCON MS (mm)	APMX (mm)	OAL (mm)	NOF	LU (mm)	DN (mm)
C9086.0	6.00	6.00	13.00	57.0	4	-	-
C9087.0	7.00	10.00	16.00	66.0	4	-	-
C9088.0	8.00	10.00	19.00	69.0	4	-	-
C9089.0	9.00	10.00	19.00	69.0	4	-	-
C90810.0	10.00	10.00	22.00	72.0	4	31.50	9.50
C90811.0	11.00	12.00	22.00	79.0	4	-	-
C90812.0	12.00	12.00	26.00	83.0	4	37.50	11.50
C90813.0	13.00	12.00	26.00	83.0	4	37.50	11.50
C90814.0	14.00	12.00	26.00	83.0	4	37.50	11.50
C90816.0	16.00	16.00	32.00	92.0	4	43.50	15.50
C90818.0	18.00	16.00	32.00	92.0	4	43.50	15.50
C90820.0	20.00	20.00	38.00	104.0	4	53.50	19.50
C90822.0	22.00	20.00	38.00	104.0	4	53.50	19.50
C90825.0	25.00	25.00	45.00	121.0	6	64.50	24.50
C90830.0	30.00	25.00	45.00	121.0	6	64.50	24.50
C90832.0	32.00	32.00	53.00	133.0	6	72.50	31.50

C492

DORMER



Fraise d'ébauche en HSS-E-PM à 3, 4 ou 6 dents, série longue, revêtement Alcrona

Fraise à 3, 4 ou 6 dents avec un profil HRA et une grande longueur de coupe brisant les copeaux efficacement lors de l'ébauche de profils profonds. Queue détalonnée sur diamètre de coupe égal ou supérieur à 10 mm. Une hélice à 35° réduit les vibrations et améliore les performances en ébauche. Le revêtement Alcrona améliore les performances et prolonge la durée de vie de l'outil.

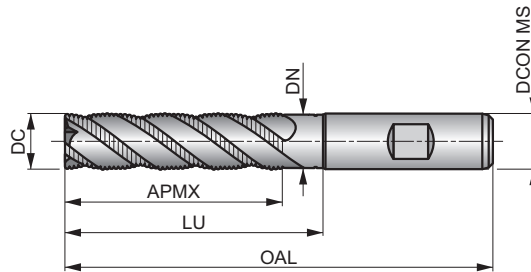

HSS-E PM	HRA	NOF 3-6
	λ 35°	γ 12°
DIN 1835B	Alcrona	DC k12
	DIN 844L	

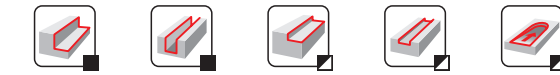

Adéquation du groupe de matériaux de la pièce, valeurs de départ pour la vitesse de coupe (m/min) et code alpha. Tableaux d'avances par dent et facteurs de correction à partir de la page 261.

P2.2 ■ 83 E	P2.3 ■ 73 D	P3.1 ■ 72 E	P3.2 ■ 58 D	P3.3 ■ 49 D	P4.1 ■ 43 D	P4.2 ■ 37 D	P4.3 ■ 30 D	M1.1 ■ 59 E	M1.2 ■ 50 E	M2.1 ■ 53 E	M2.2 ■ 43 D	M3.1 ■ 42 D	M3.2 ■ 36 D
M3.3 ■ 32 C	M4.1 ■ 23 C	K1.1 ■ 55 E	K1.2 ■ 41 E	K1.3 ■ 31 E	K2.1 ■ 97 E	K2.2 ■ 79 E	K2.3 ■ 63 D	K3.1 ■ 86 E	K3.2 ■ 66 E	K3.3 ■ 53 D	K4.1 ■ 80 D	K4.2 ■ 60 D	K4.3 ■ 44 D
K4.4 ■ 38 C	K4.5 ■ 31 C	K5.1 ■ 90 D	K5.2 ■ 68 D	K5.3 ■ 52 D	N3.1 ■ 104 E	N3.2 ■ 61 E	S1.1 ■ 41 D	S1.2 ■ 34 D	S1.3 ■ 15 C	S2.1 ■ 32 C	S2.2 ■ 14 C	S3.1 ■ 24 C	S3.2 ■ 10 C
S4.1 ■ 19 C	S4.2 ■ 8 C												

DCON MS tolérance h6.

Product	DC (mm)	DCON MS (mm)	APMX (mm)	OAL (mm)	NOF	LU (mm)	DN (mm)
C4926.0	6.00	6.00	24.00	68.0	3	–	–
C4928.0	8.00	10.00	38.00	88.0	3	–	–
C49210.0	10.00	10.00	45.00	95.0	4	54.50	9.50
C49212.0	12.00	12.00	53.00	110.0	4	64.50	11.50
C49214.0	14.00	12.00	53.00	110.0	4	64.50	11.50
C49216.0	16.00	16.00	63.00	123.0	4	74.50	15.50
C49218.0	18.00	16.00	63.00	123.0	4	74.50	15.50
C49220.0	20.00	20.00	75.00	141.0	4	90.50	19.50
C49222.0	22.00	20.00	75.00	141.0	4	90.50	19.50
C49225.0	25.00	25.00	90.00	166.0	6	109.50	24.50
C49230.0	30.00	25.00	90.00	166.0	6	109.50	24.50

C948

DORMER



Fraise d'ébauche en HSS-E-PM à 4 ou 6 dents, série longue, revêtement Alcrona

Fraise à 4 ou 6 dents avec un profil NRA et une grande longueur de coupe brisant les copeaux efficacement lors de l'ébauche de profils profonds. Une hélice à 35° réduit les vibrations et améliore les performances dans les opérations d'ébauche. Queue détalonnée sur diamètre de coupe égal ou supérieur à 10 mm. Le revêtement Alcrona améliore les performances et prolonge la durée de vie de l'outil.

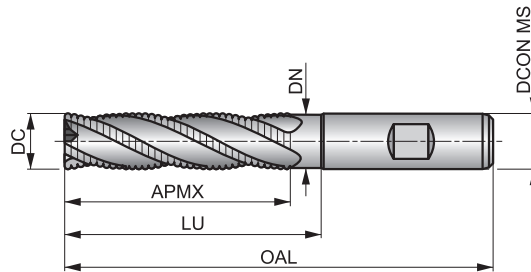

HSS-E PM	NRA	NOF 4-6
	λ 35°	γ 12°
DIN 1835B	Alcrona	DC k12
	DIN 844L	

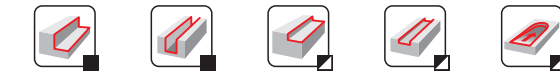

Adéquation du groupe de matériaux de la pièce, valeurs de départ pour la vitesse de coupe (m/min) et code alpha. Tableaux d'avances par dent et facteurs de correction à partir de la page 261.

P2.2 ■ 83 F	P2.3 ■ 73 E	P3.1 ■ 72 F	P3.2 ■ 58 E	P3.3 ■ 49 E	P4.1 ■ 43 E	P4.2 ■ 37 E	P4.3 ■ 30 E	M1.1 ■ 59 F	M1.2 ■ 50 F	M2.1 ■ 53 F	M2.2 ■ 43 E	M3.1 ■ 42 E	M3.2 ■ 36 E
M3.3 ■ 32 D	M4.1 ■ 23 D	K1.1 ■ 55 F	K1.2 ■ 41 F	K1.3 ■ 31 F	K2.1 ■ 97 F	K2.2 ■ 79 F	K2.3 ■ 63 E	K3.1 ■ 86 F	K3.2 ■ 66 F	K3.3 ■ 53 E	K4.1 ■ 80 E	K4.2 ■ 60 E	K4.3 ■ 44 E
K4.4 ■ 38 D	K4.5 ■ 31 D	K5.1 ■ 90 E	K5.2 ■ 68 E	K5.3 ■ 52 E	N3.1 ■ 83 F	N3.2 ■ 49 F	S1.1 ■ 41 E	S1.2 ■ 34 E	S1.3 ■ 15 D	S2.1 ■ 32 D	S2.2 ■ 14 D	S3.1 ■ 24 D	S3.2 ■ 10 D
S4.1 ■ 19 D	S4.2 ■ 8 D												

DCON MS tolérance h6.

Product	DC (mm)	DCON MS (mm)	APMX (mm)	OAL (mm)	NOF	LU (mm)	DN (mm)
C9486.0	6.00	6.00	24.00	68.0	4	–	–
C9488.0	8.00	10.00	38.00	88.0	4	–	–
C94810.0	10.00	10.00	45.00	95.0	4	54.50	9.50
C94812.0	12.00	12.00	53.00	110.0	4	64.50	11.50
C94814.0	14.00	12.00	53.00	110.0	4	64.50	11.50
C94816.0	16.00	16.00	63.00	123.0	4	74.50	15.50
C94818.0	18.00	16.00	63.00	123.0	4	74.50	15.50
C94820.0	20.00	20.00	75.00	141.0	4	90.50	19.50
C94825.0	25.00	25.00	90.00	166.0	6	109.50	24.50
C94832.0	32.00	32.00	106.00	186.0	6	125.50	31.50

Code de matériau du corps (BMC)	HSS-E PM	HSS-E PM	HSS-E PM	HSS-E PM	HSS-E PM	HSS-E PM						
Profil de fraise	N	N	N	N	N	N						
Nombre de goujures (NOF)	NOF 3-4	NOF 3-6	NOF 4-6	NOF 4-5	NOF 4-6	NOF 4-6						
Longueur de coupe												
Angle d'hélice de goujure (FHA)	λ 45°	λ 45°	λ 30°	λ 30°	λ 30°	λ 30°						
Angle d'hélice de goujure (FHA)	λ 45°	λ 45°	λ 30°	λ 30°	λ 30°	λ 30°						
Angle de coupe radial (GAMF)	γ 12°	γ 12°	γ 12°	γ 12°	γ 12°	γ 12°						
Queue												
Revêtement	Bright	Alcrona	Bright	TiCN	Bright	TiCN						
Classe de tolérance du diamètre de coupe (TCDC)	DC k10	DC k10	DC k10	DC k10	DC k10	DC k10						
Direction de coupe												
Groupe standard de base (BSG)	DIN 844K	DIN 844K	DIN 844K	DIN 844K	DIN 844L	DIN 844L						

Code de famille de produits		C299	C907	C247	C246	C273	C295					
Plage de diamètres de coupe PSF		3.00 – 20.00	3.00 – 32.00	2.00 – 40.00	2.00 – 25.00	2.00 – 40.00	2.00 – 40.00					
P	P1	■	■	■	■	■	■					
	P2	■	■	■	■	■	■					
	P3	■	■	■	■	■	■					
	P4	■	■	■	■	■	■					
M	M1	■	■	■	■	■	■					
	M2	■	■	■	■	■	■					
	M3	■	■	■	■	■	■					
	M4	■	■	■	■	■	■					
K	K1	■	■	■	■	■	■					
	K2	■	■	■	■	■	■					
	K3	■	■	■	■	■	■					
	K4	■	■	■	■	■	■					
	K5	■	■	■	■	■	■					
N	N1			■	■	■	■					
	N2			■	■	■	■					
	N3	■	■	■	■	■	■					
	N4			■	■	■	■					
	N5			■	■	■	■					
S	S1	■	■	■	■	■	■					
	S2	■	■	■	■	■	■					
	S3	■	■	■	■	■	■					
	S4	■	■	■	■	■	■					
H	H1											
	H2											
	H3											
	H4											

C299

DORMER



Fraise de finition en HSS-E-PM à 3 ou 4 dents, série courte, finition brillante

Fraise à 3 ou 4 dents avec hélice à 45° et une longueur de coupe courte offrant une grande rigidité pour les applications générales de fraisage de profil et de ramping. Prévue pour l'usinage de matériaux plus résistants. Queue détalonnée sur un diamètre de coupe égal ou supérieur à 10 mm.

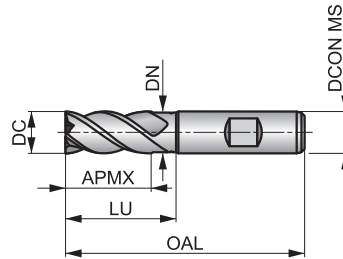

HSS-E PM	N	NOF 3-4
	λ 45°	γ 12°
DIN 1835B	Bright	DC k10
	DIN 844K	



Adéquation du groupe de matériaux de la pièce, valeurs de départ pour la vitesse de coupe (m/min) et code alpha. Tableaux d'avances par dent et facteurs de correction à partir de la page 261.

P2.2 ■ 37 D	P2.3 ■ 33 C	P3.1 ■ 32 D	P3.2 ■ 26 C	P3.3 ■ 22 C	P4.1 ■ 19 C	P4.2 ■ 16 C	P4.3 ■ 13 C	M1.1 ■ 36 D	M1.2 ■ 30 D	M2.1 ■ 32 D	M2.2 ■ 26 C	M3.1 ■ 24 C	M3.2 ■ 21 C
M3.3 ■ 19 B	M4.1 ■ 13 B	K1.1 ■ 30 D	K1.2 ■ 22 D	K1.3 ■ 17 D	K2.1 ■ 55 D	K2.2 ■ 45 D	K2.3 ■ 36 C	K3.1 ■ 49 D	K3.2 ■ 37 D	K3.3 ■ 30 B	K4.1 ■ 45 C	K4.2 ■ 34 C	K4.3 ■ 25 C
K4.4 ■ 22 B	K4.5 ■ 18 B	K5.1 ■ 51 C	K5.2 ■ 39 C	K5.3 ■ 30 C	N3.1 ■ 43 D	N3.2 ■ 25 D	S1.1 ■ 29 C	S1.2 ■ 57 C	S1.3 ■ 10 B	S2.1 ■ 17 B	S2.2 ■ 7 B	S3.1 ■ 13 B	S3.2 ■ 5 B
S4.1 ■ 10 B	S4.2 ■ 4 B												

DCON MS tolérance h6.

Product	DC (mm)	DCON MS (mm)	APMX (mm)	OAL (mm)	NOF	LU (mm)	DN (mm)
C2993.0	3.00	6.00	8.00	52.0	3	–	–
C2994.0	4.00	6.00	11.00	55.0	3	–	–
C2995.0	5.00	6.00	13.00	57.0	3	–	–
C2996.0	6.00	6.00	13.00	57.0	3	–	–
C2998.0	8.00	10.00	19.00	69.0	4	–	–
C29910.0	10.00	10.00	22.00	72.0	4	31.50	9.50
C29912.0	12.00	12.00	26.00	83.0	4	37.50	11.50
C29914.0	14.00	12.00	26.00	83.0	4	37.50	11.50
C29916.0	16.00	16.00	32.00	92.0	4	43.50	15.50
C29920.0	20.00	20.00	38.00	104.0	4	53.50	19.50

C907

DORMER



Fraise de finition en HSS-E-PM à 3, 4, 5 ou 6 dents, série courte, revêtement Alcrona

Fraise à 3, 4, 5 ou 6 dents avec hélice à 45° et une longueur de coupe courte offrant une grande rigidité pour les applications générales de fraisage de profil et de ramping. Convient pour l'usinage de matériaux plus résistants. Queue détalonnée sur diamètre de coupe égal ou supérieur à 10 mm. Le revêtement Alcrona améliore les performances et prolonge la durée de vie de l'outil.

HSS-E PM	N	NOF 3-6
	λ 45°	γ 12°
DIN 1835B	Alcrona	DC k10
	DIN 844K	

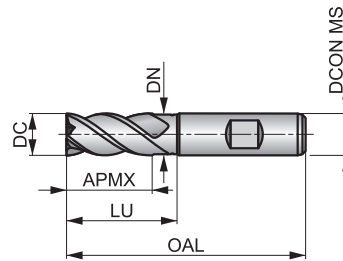

Adéquation du groupe de matériaux de la pièce, valeurs de départ pour la vitesse de coupe (m/min) et code alpha. Tableaux d'avances par dent et facteurs de correction à partir de la page 261.

P2.2 ■ 95 D	P2.3 ■ 84 C	P3.1 ■ 81 D	P3.2 ■ 65 C	P3.3 ■ 55 C	P4.1 ■ 48 C	P4.2 ■ 41 C	P4.3 ■ 34 C	M1.1 ■ 69 D	M1.2 ■ 58 D	M2.1 ■ 61 D	M2.2 ■ 50 C	M3.1 ■ 47 C	M3.2 ■ 40 C
M3.3 ■ 36 B	M4.1 ■ 25 B	K1.1 ■ 60 D	K1.2 ■ 44 D	K1.3 ■ 33 D	K2.1 ■ 111 D	K2.2 ■ 90 D	K2.3 ■ 72 C	K3.1 ■ 98 D	K3.2 ■ 75 D	K3.3 ■ 61 B	K4.1 ■ 91 C	K4.2 ■ 68 C	K4.3 ■ 50 C
K4.4 ■ 43 B	K4.5 ■ 36 B	K5.1 ■ 103 C	K5.2 ■ 77 C	K5.3 ■ 60 C	N3.1 ■ 93 D	N3.2 ■ 55 D	S1.1 ■ 45 C	S1.2 ■ 85 C	S1.3 ■ 15 B	S2.1 ■ 33 B	S2.2 ■ 14 B	S3.1 ■ 25 B	S3.2 ■ 10 B
S4.1 ■ 20 B	S4.2 ■ 8 B												

DCON MS tolérance h6.

Product	DC (mm)	DCON MS (mm)	APMX (mm)	OAL (mm)	NOF	LU (mm)	DN (mm)
C9073.0	3.00	6.00	8.00	52.0	3	—	—
C9074.0	4.00	6.00	11.00	55.0	3	—	—
C9075.0	5.00	6.00	13.00	57.0	3	—	—
C9076.0	6.00	6.00	13.00	57.0	3	—	—
C9078.0	8.00	10.00	19.00	69.0	4	—	—
C90710.0	10.00	10.00	22.00	72.0	4	31.50	9.50
C90712.0	12.00	12.00	26.00	83.0	4	37.50	11.50
C90714.0	14.00	12.00	26.00	83.0	4	37.50	11.50
C90716.0	16.00	16.00	32.00	92.0	4	43.50	15.50
C90718.0	18.00	16.00	32.00	92.0	4	43.50	15.50
C90720.0	20.00	20.00	38.00	104.0	4	53.50	19.50
C90722.0	22.00	20.00	38.00	104.0	5	53.50	19.50
C90725.0	25.00	25.00	45.00	121.0	5	64.50	24.50
C90728.0	28.00	25.00	45.00	121.0	6	64.50	24.50
C90730.0	30.00	25.00	45.00	121.0	6	64.50	24.50
C90732.0	32.00	32.00	53.00	133.0	6	72.50	31.50

C247

DORMER



Fraise de finition en HSS-E-PM à 4, 5, 6 ou 8 dents, série courte, finition brillante

Fraise à 4, 5 ou 6 dents avec une longueur de coupe courte offrant une grande rigidité pour les applications générales de fraisage de profil et de ramping dans les aciers doux et les matériaux non-ferreux.

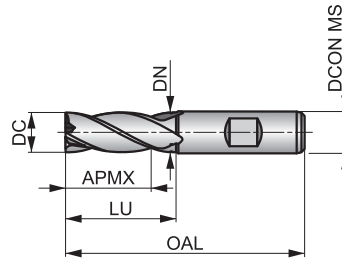

HSS-E PM	N	NOF 4-6
	λ 30°	γ 12°
DIN 1835B	Bright	DC k10
	DIN 844K	



Adéquation du groupe de matériaux de la pièce, valeurs de départ pour la vitesse de coupe (m/min) et code alpha. Tableaux d'avances par dent et facteurs de correction à partir de la page 261.

P1.1 ■ 53 D	P1.2 ■ 59 D	P1.3 ■ 61 D	P2.1 ■ 45 D	P2.2 ■ 40 D	P3.1 ▣ 36 D	P3.2 ▣ 29 C	P4.1 ▣ 22 C	M1.1 ▣ 34 D	M1.2 ▣ 29 D	M2.1 ▣ 31 D	M2.2 ▣ 25 C	K1.1 ▣ 30 D	K1.2 ▣ 22 D
K1.3 ▣ 17 D	K2.1 ▣ 55 D	K2.2 ▣ 45 D	K2.3 ▣ 36 C	K3.1 ▣ 49 D	K3.2 ▣ 37 D	K3.3 ▣ 30 B	K4.1 ▣ 45 C	K4.2 ▣ 34 C	K4.3 ▣ 25 C	K4.4 ▣ 22 B	K4.5 ▣ 18 B	K5.1 ▣ 51 C	K5.2 ▣ 39 C
K5.3 ▣ 30 C	N1.1 ▣ 95 F	N1.2 ▣ 71 E	N1.3 ▣ 48 E	N2.1 ▣ 48 D	N2.2 ▣ 43 D	N2.3 ▣ 31 D	N3.1 ■ 50 D	N3.2 ■ 29 D	N3.3 ■ 15 D	N4.1 ▣ 50 D	S1.1 ■ 30 C	S1.2 ▣ 25 C	S2.1 ▣ 20 B
S3.1 ▣ 15 B	S4.1 ▣ 12 B												

DCON MS tolérance h6.

Product	DC (inch)	DC (mm)	DCON MS (mm)	APMX (mm)	OAL (mm)	NOF	LU (mm)	DN (mm)
C2472.0	–	2.00	6.00	7.00	51.0	4	–	–
C2472.5	–	2.50	6.00	8.00	52.0	4	–	–
C2473.0	–	3.00	6.00	8.00	52.0	4	–	–
C2471/8 ²⁾	1/8	3.18	6.00	10.00	54.0	4	–	–
C2473.5	–	3.50	6.00	10.00	54.0	4	–	–
C2474.0	–	4.00	6.00	11.00	55.0	4	–	–
C2474.5	–	4.50	6.00	11.00	55.0	4	–	–
C2473/16 ²⁾	3/16	4.76	6.00	13.00	57.0	4	–	–
C2475.0	–	5.00	6.00	13.00	57.0	4	–	–
C2475.5	–	5.50	6.00	13.00	57.0	4	–	–
C2476.0	–	6.00	6.00	13.00	57.0	4	–	–
C2471/4 ²⁾	1/4	6.35	10.00	16.00	66.0	4	–	–
C2476.5	–	6.50	10.00	16.00	66.0	4	–	–
C2477.0	–	7.00	10.00	16.00	66.0	4	–	–
C2477.5	–	7.50	10.00	16.00	66.0	4	–	–
C2475/16 ²⁾	5/16	7.94	10.00	19.00	69.0	4	–	–
C2478.0	–	8.00	10.00	19.00	69.0	4	–	–
C2478.5	–	8.50	10.00	19.00	69.0	4	–	–
C2479.0	–	9.00	10.00	19.00	69.0	4	–	–
C2479.5	–	9.50	10.00	19.00	69.0	4	–	–
C2473/8 ²⁾	3/8	9.52	10.00	22.00	72.0	4	31.50	9.50
C24710.0	–	10.00	10.00	22.00	72.0	4	31.50	9.50
C24711.0	–	11.00	12.00	22.00	79.0	4	–	–
C24712.0	–	12.00	12.00	26.00	83.0	4	37.50	11.50
C2471/2 ²⁾	1/2	12.70	12.00	26.00	83.0	4	37.50	11.50

Product	DC	DC	DCON MS	APMX	OAL	NOF	LU	DN
	(inch)	(mm)	(mm)	(mm)	(mm)		(mm)	(mm)
C24713.0	–	13.00	12.00	26.00	83.0	4	37.50	11.50
C24714.0	–	14.00	12.00	26.00	83.0	4	37.50	11.50
C2479/16²⁾	9/16	14.29	12.00	26.00	83.0	4	37.50	11.50
C24715.0	–	15.00	12.00	26.00	83.0	4	37.50	11.50
C2475/8²⁾	5/8	15.88	16.00	32.00	92.0	4	43.50	15.50
C24716.0	–	16.00	16.00	32.00	92.0	4	43.50	15.50
C24717.0	–	17.00	16.00	32.00	92.0	4	43.50	15.50
C24718.0	–	18.00	16.00	32.00	92.0	4	43.50	15.50
C24719.0	–	19.00	16.00	32.00	92.0	4	43.50	15.50
C2473/4²⁾	3/4	19.05	20.00	38.00	104.0	4	53.50	18.50
C24720.0	–	20.00	20.00	38.00	104.0	4	53.50	19.50
C24721.0	–	21.00	20.00	38.00	104.0	4	53.50	19.50
C24722.0	–	22.00	20.00	38.00	104.0	5	53.50	19.50
C2477/8²⁾	7/8	22.22	20.00	38.00	104.0	5	53.50	19.50
C24723.0	–	23.00	20.00	38.00	104.0	5	53.50	19.50
C24724.0	–	24.00	25.00	45.00	121.0	5	64.50	23.50
C24725.0	–	25.00	25.00	45.00	121.0	5	64.50	24.50
C2471²⁾	1"	25.40	25.00	45.00	121.0	5	64.50	24.50
C24726.0	–	26.00	25.00	45.00	121.0	6	64.50	24.50
C24728.0	–	28.00	25.00	45.00	121.0	6	64.50	24.50
C24730.0	–	30.00	25.00	45.00	121.0	6	64.50	24.50
C24732.0	–	32.00	32.00	53.00	133.0	6	72.50	31.50
C24736.0¹⁾	–	36.00	32.00	53.00	133.0	6	72.50	31.50
C24740.0¹⁾	–	40.00	40.00	63.00	155.0	6	84.50	39.00

¹⁾ Disponible seulement en HSS-E; pas de coupe au centre.

²⁾ DC tolérance +0.0025 pouces / -0.0005 pouces.

C246

DORMER



Fraise de finition en HSS-E-PM à 4 ou 5 dents, série courte, revêtement TiCN

Fraise à 4 ou 5 dents avec une longueur de coupe courte offrant une grande rigidité pour les applications générales de fraisage de profil et de ramping. Le revêtement TiCN augmente la durée de vie de la fraise et améliore les performances lors du fraisage de matériaux durs et abrasifs.

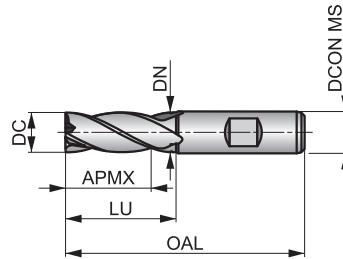

HSS-E PM	N	NOF 4-5
	λ 30°	γ 12°
DIN 1835B	TiCN	DC k10
	DIN 844K	



Adéquation du groupe de matériaux de la pièce, valeurs de départ pour la vitesse de coupe (m/min) et code alpha. Tableaux d'avances par dent et facteurs de correction à partir de la page 261.

P1.1 ■ 113 D	P1.2 ■ 126 D	P1.3 ■ 131 D	P2.1 ■ 97 D	P2.2 ■ 85 D	P2.3 ▣ 75 C	P3.1 ■ 74 D	P3.2 ■ 59 C	P3.3 ▣ 50 C	P4.1 ■ 44 C	P4.2 ▣ 37 C	P4.3 ▣ 31 C	M1.1 ▣ 62 D	M1.2 ▣ 52 D
M2.1 ▣ 55 D	M2.2 ▣ 45 C	M3.3 ▣ 26 B	M4.1 ▣ 25 B	K1.1 ■ 55 D	K1.2 ■ 41 D	K1.3 ■ 31 D	K2.1 ■ 97 D	K2.2 ■ 79 D	K2.3 ■ 63 C	K3.1 ■ 86 D	K3.2 ■ 66 D	K3.3 ■ 53 B	K4.1 ■ 80 C
K4.2 ■ 60 C	K4.3 ■ 44 C	K4.4 ■ 38 B	K4.5 ■ 31 B	K5.1 ■ 90 C	K5.2 ■ 68 C	K5.3 ■ 52 C	N1.1 ▣ 159 F	N1.2 ▣ 120 E	N1.3 ▣ 80 E	N2.1 ▣ 80 D	N2.2 ▣ 72 D	N2.3 ■ 51 D	N3.1 ■ 84 D
N3.2 ■ 50 D	N3.3 ■ 25 D	N4.1 ▣ 84 D	S1.1 ■ 43 C	S1.2 ■ 35 C	S1.3 ▣ 15 B	S2.1 ■ 32 B	S2.2 ▣ 14 B	S3.1 ■ 24 B	S3.2 ▣ 10 B	S4.1 ■ 19 B	S4.2 ▣ 8 B		

DCON MS tolérance h6.

Product	DC (mm)	DCON MS (mm)	APMX (mm)	OAL (mm)	NOF	LU (mm)	DN (mm)
C2462.0	2.00	6.00	7.00	51.0	4	–	–
C2463.0	3.00	6.00	8.00	52.0	4	–	–
C2464.0	4.00	6.00	11.00	55.0	4	–	–
C2465.0	5.00	6.00	13.00	57.0	4	–	–
C2466.0	6.00	6.00	13.00	57.0	4	–	–
C2467.0	7.00	10.00	16.00	66.0	4	–	–
C2468.0	8.00	10.00	19.00	69.0	4	–	–
C24610.0	10.00	10.00	22.00	72.0	4	31.50	9.50
C24611.0	11.00	12.00	22.00	79.0	4	–	–
C24612.0	12.00	12.00	26.00	83.0	4	37.50	11.50
C24613.0	13.00	12.00	26.00	83.0	4	37.50	11.50
C24614.0	14.00	12.00	26.00	83.0	4	37.50	11.50
C24615.0	15.00	12.00	26.00	83.0	4	37.50	11.50
C24616.0	16.00	16.00	32.00	92.0	4	43.50	15.50
C24618.0	18.00	16.00	32.00	92.0	4	43.50	15.50
C24620.0	20.00	20.00	38.00	104.0	4	53.50	19.50
C24622.0	22.00	20.00	38.00	104.0	5	53.50	19.50
C24625.0	25.00	25.00	45.00	121.0	5	64.50	24.50

C273

DORMER



Fraise de finition en HSS-E-PM à 4, 5 ou 6 dents, série longue, finition brillante

Fraise à 4, 5 ou 6 dents avec une grande longueur de coupe offrant une grande rigidité pour la finition de profils profonds dans les aciers doux et les matériaux non-ferreux, tels que l'aluminium et les alliages de titane à résistance moyenne.

HSS-E PM	N	NOF 4-6
	λ 30°	γ 12°
DIN 1835B	Bright	DC k10
	DIN 844L	

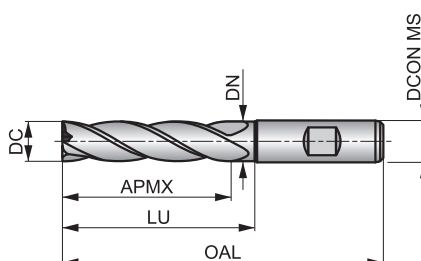

Adéquation du groupe de matériaux de la pièce, valeurs de départ pour la vitesse de coupe (m/min) et code alpha. Tableaux d'avances par dent et facteurs de correction à partir de la page 261.

P1.1 ■ 46 C	P1.2 ■ 52 C	P1.3 ■ 54 C	P2.1 ■ 40 C	P2.2 ■ 35 C	P3.1 ■ 32 C	P3.2 ■ 26 B	P4.1 ■ 19 B	M1.1 ■ 14 C	M1.2 ■ 12 C	M2.1 ■ 12 C	M2.2 ■ 10 B	K1.1 ■ 25 C	K1.2 ■ 19 C
K1.3 ■ 14 C	K2.1 ■ 49 C	K2.2 ■ 40 C	K2.3 ■ 32 B	K3.1 ■ 44 C	K3.2 ■ 33 C	K3.3 ■ 27 A	K4.1 ■ 40 B	K4.2 ■ 30 B	K4.3 ■ 22 B	K4.4 ■ 19 A	K4.5 ■ 16 A	K5.1 ■ 46 B	K5.2 ■ 34 B
K5.3 ■ 27 B	N1.1 ■ 81 E	N1.2 ■ 60 D	N1.3 ■ 41 D	N2.1 ■ 41 C	N2.2 ■ 37 C	N2.3 ■ 26 C	N3.1 ■ 43 C	N3.2 ■ 25 C	N3.3 ■ 13 C	N4.1 ■ 43 C	S1.1 ■ 25 B	S1.2 ■ 20 B	S2.1 ■ 13 A
S3.1 ■ 10 A	S4.1 ■ 8 A												

DCON MS tolérance h6.

Product	DC (inch)	DC (mm)	DCON MS (mm)	APMX (mm)	OAL (mm)	NOF	LU (mm)	DN (mm)
C2732.0	–	2.00	6.00	10.00	54.0	4	–	–
C2732.5	–	2.50	6.00	12.00	56.0	4	–	–
C2733.0	–	3.00	6.00	12.00	56.0	4	–	–
C2731/8 ²⁾	1/8	3.18	6.00	15.00	59.0	4	–	–
C2733.5	–	3.50	6.00	15.00	59.0	4	–	–
C2734.0	–	4.00	6.00	19.00	63.0	4	–	–
C2734.5	–	4.50	6.00	19.00	63.0	4	–	–
C2733/16 ²⁾	3/16	4.76	6.00	24.00	68.0	4	–	–
C2735.0	–	5.00	6.00	24.00	68.0	4	–	–
C2735.5	–	5.50	6.00	24.00	68.0	4	–	–
C2736.0	–	6.00	6.00	24.00	68.0	4	–	–
C2731/4 ²⁾	1/4	6.35	10.00	30.00	80.0	4	–	–
C2737.0	–	7.00	10.00	30.00	80.0	4	–	–
C2738.0	–	8.00	10.00	38.00	88.0	4	–	–
C2739.0	–	9.00	10.00	38.00	88.0	4	–	–
C2733/8 ²⁾	3/8	9.52	10.00	45.00	95.0	4	54.50	9.50
C27310.0	–	10.00	10.00	45.00	95.0	4	54.50	9.50
C27311.0	–	11.00	12.00	45.00	102.0	4	–	–
C27312.0	–	12.00	12.00	53.00	110.0	4	64.50	11.50
C2731/2 ²⁾	1/2	12.70	12.00	53.00	110.0	4	64.50	11.50
C27313.0	–	13.00	12.00	53.00	110.0	4	64.50	11.50
C27314.0	–	14.00	12.00	53.00	110.0	4	64.50	11.50
C27315.0	–	15.00	12.00	53.00	110.0	4	64.50	11.50
C2735/8 ²⁾	5/8	15.88	16.00	63.00	123.0	4	74.50	15.50
C27316.0	–	16.00	16.00	63.00	123.0	4	74.50	15.50

Product	DC	DC	DCON MS	APMX	OAL	NOF	LU	DN
	(inch)	(mm)	(mm)	(mm)	(mm)		(mm)	(mm)
C27318.0	–	18.00	16.00	63.00	123.0	4	74.50	15.50
C2733/4 ²⁾	3/4	19.05	20.00	75.00	141.0	4	90.50	18.50
C27320.0	–	20.00	20.00	75.00	141.0	4	90.50	19.50
C27322.0	–	22.00	20.00	75.00	141.0	5	90.50	19.50
C27325.0	–	25.00	25.00	90.00	166.0	5	109.50	24.50
C2731 ²⁾	1"	25.40	25.00	90.00	166.0	5	109.50	24.50
C27330.0	–	30.00	25.00	90.00	166.0	6	109.50	24.50
C27332.0	–	32.00	32.00	106.00	186.0	6	125.50	31.50
C27340.0 ¹⁾	–	40.00	40.00	125.00	217.0	6	146.50	39.00

¹⁾ Disponible seulement en HSS-E; pas de coupe au centre.

²⁾ DC tolérance +0.0025 pouces / -0.0005 pouces.

C295



Fraise de finition en HSS-E-PM à 4, 5 ou 6 dents, série longue, revêtement TiCN

Fraise à 4, 5 ou 6 dents avec une longueur de coupe importante offrant une grande rigidité pour la finition de profils profonds. Le revêtement TiCN augmente la durée de vie de la fraise et améliore les performances lors du fraisage de matériaux durs et abrasifs.

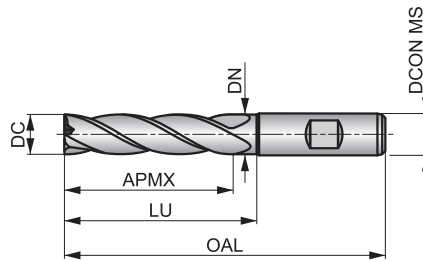

HSS-E PM	N	NOF 4-6
	λ 30°	γ 12°
DIN 1835B	TiCN	DC k10
	DIN 844L	



Adéquation du groupe de matériaux de la pièce, valeurs de départ pour la vitesse de coupe (m/min) et code alpha. Tableaux d'avances par dent et facteurs de correction à partir de la page 261.

P1.1 ■ 99 C	P1.2 ■ 111 C	P1.3 ■ 115 C	P2.1 ■ 85 C	P2.2 ■ 75 C	P2.3 ▣ 66 B	P3.1 ■ 66 C	P3.2 ■ 53 B	P3.3 ▣ 45 B	P4.1 ■ 40 B	P4.2 ▣ 34 B	P4.3 ▣ 27 B	M1.1 ▣ 55 C	M1.2 ▣ 46 C
M2.1 ▣ 49 C	M2.2 ▣ 40 B	M3.3 ▣ 21 A	M4.1 ▣ 20 A	K1.1 ■ 50 C	K1.2 ■ 37 C	K1.3 ■ 28 C	K2.1 ■ 86 C	K2.2 ■ 70 C	K2.3 ■ 56 B	K3.1 ■ 76 C	K3.2 ■ 58 C	K3.3 ■ 47 A	K4.1 ■ 71 B
K4.2 ■ 53 B	K4.3 ■ 39 B	K4.4 ■ 33 A	K4.5 ■ 28 A	K5.1 ■ 80 B	K5.2 ■ 60 B	K5.3 ■ 46 B	N1.1 ▣ 139 E	N1.2 ▣ 105 D	N1.3 ▣ 70 D	N2.1 ▣ 70 C	N2.2 ■ 63 C	N2.3 ■ 45 C	N3.1 ■ 73 C
N3.2 ■ 43 C	N3.3 ■ 22 C	N4.1 ▣ 73 C	S1.1 ■ 40 B	S1.2 ■ 30 B	S1.3 ▣ 15 A	S2.1 ■ 27 A	S2.2 ▣ 14 A	S3.1 ■ 20 A	S3.2 ▣ 10 A	S4.1 ■ 16 A	S4.2 ▣ 8 A		

DCON MS tolérance h6.

Product	DC (mm)	DCON MS (mm)	APMX (mm)	OAL (mm)	NOF	LU (mm)	DN (mm)
C2952.0	2.00	6.00	10.00	54.0	4	–	–
C2953.0	3.00	6.00	12.00	56.0	4	–	–
C2954.0	4.00	6.00	19.00	63.0	4	–	–
C2955.0	5.00	6.00	24.00	68.0	4	–	–
C2956.0	6.00	6.00	24.00	68.0	4	–	–
C2957.0	7.00	10.00	30.00	80.0	4	–	–
C2958.0	8.00	10.00	38.00	88.0	4	–	–
C2959.0	9.00	10.00	38.00	88.0	4	–	–
C29510.0	10.00	10.00	45.00	95.0	4	54.50	9.50
C29512.0	12.00	12.00	53.00	110.0	4	64.50	11.50
C29515.0	15.00	12.00	53.00	110.0	4	64.50	11.50
C29516.0	16.00	16.00	63.00	123.0	4	74.50	15.50
C29518.0	18.00	16.00	63.00	123.0	4	74.50	15.50
C29520.0	20.00	20.00	75.00	141.0	4	90.50	19.50
C29525.0	25.00	25.00	90.00	166.0	5	109.50	24.50
C29530.0	30.00	25.00	90.00	166.0	6	109.50	24.50
C29532.0	32.00	32.00	106.00	186.0	6	125.50	31.50
C29540.0 ¹⁾	40.00	40.00	125.00	217.0	6	146.50	39.00

¹⁾ Disponible seulement en HSS-E; pas de coupe au centre.

Code de matériau du corps (BMC)	HSS-E PM	HSS-E	HSS-E																	
Profil de fraise	N	N	N																	
Nombre de goujures (NOF)	NOF 3-5	NOF 2	NOF 2																	
Longueur de coupe																				
Angle d'hélice de goujure (FHA)	λ 45°	λ 30°	λ 30°																	
Angle d'hélice de goujure (FHA)	λ 45°	λ 30°	λ 30°																	
Angle de coupe radial (GAMF)	γ 12°	γ 12°	γ 12°																	
Queue																				
Revêtement	Alcrona	Bright	Bright																	
Classe de tolérance du diamètre de coupe (TCDC)	DC k10	DC e8	DC e8																	
Direction de coupe																				
Groupe standard de base (BSG)	DIN 844L	DIN 327D	DIN 844K																	

Code de famille de produits		C920	C500	C505																	
Plage de diamètres de coupe PSF		6.00 – 25.00	2.00 – 20.00	3.00 – 30.00																	
		46	47	48																	
P	P1	■	■	■																	
	P2	■	■	■																	
	P3	■	■	■																	
	P4	■	■	■																	
M	M1	■	■	■																	
	M2	■	■	■																	
	M3	■	■	■																	
	M4	■	■	■																	
K	K1	■	■	■																	
	K2	■	■	■																	
	K3	■	■	■																	
	K4	■	■	■																	
	K5	■	■	■																	
N	N1		■	■																	
	N2		■	■																	
	N3	■	■	■																	
	N4		■	■																	
	N5																				
S	S1	■	■	■																	
	S2	■	■	■																	
	S3	■	■	■																	
	S4	■	■	■																	
H	H1																				
	H2																				
	H3																				
	H4																				

C920

DORMER



Fraise de finition en HSS-E-PM à 3, 4 ou 5 dents, série longue, revêtement Alcrona

Fraise à 3, 4 ou 5 dents avec hélice à 45° et une grande longueur de coupe offrant une grande rigidité pour la finition de profils profonds. Conçue pour l'usinage de matériaux plus résistants. Queue détalonnée sur diamètre de coupe égal ou supérieur à 10 mm pour éviter le contact de l'outil avec la paroi et augmenter la portée. Le revêtement Alcrona prolonge la durée de vie de l'outil.

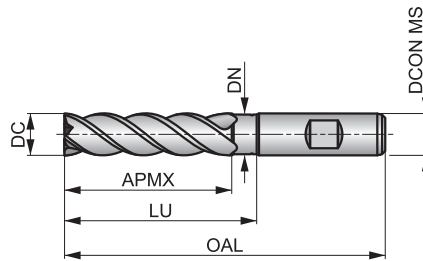

HSS-E PM	N	NOF 3-5
	λ 45°	γ 12°
DIN 1835B	Alcrona	DC k10
	DIN 844L	

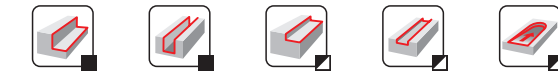

Adéquation du groupe de matériaux de la pièce, valeurs de départ pour la vitesse de coupe (m/min) et code alpha. Tableaux d'avances par dent et facteurs de correction à partir de la page 261.

P2.2 ■ 85 C	P2.3 ■ 75 B	P3.1 ■ 74 C	P3.2 ■ 59 B	P3.3 ■ 50 B	P4.1 ■ 44 B	P4.2 ■ 37 B	P4.3 ■ 31 B	M1.1 ■ 62 C	M1.2 ■ 52 C	M2.1 ■ 55 C	M2.2 ■ 45 B	M3.1 ■ 41 B	M3.2 ■ 35 B
M3.3 ■ 32 A	M4.1 ■ 25 A	K1.1 ■ 55 C	K1.2 ■ 41 C	K1.3 ■ 31 C	K2.1 ■ 98 C	K2.2 ■ 80 C	K2.3 ■ 64 B	K3.1 ■ 87 C	K3.2 ■ 67 C	K3.3 ■ 54 A	K4.1 ■ 81 B	K4.2 ■ 61 B	K4.3 ■ 45 B
K4.4 ■ 38 A	K4.5 ■ 32 A	K5.1 ■ 91 B	K5.2 ■ 69 B	K5.3 ■ 53 B	N3.1 ■ 83 C	N3.2 ■ 49 C	S1.1 ■ 40 B	S1.2 ■ 35 B	S1.3 ■ 15 A	S2.1 ■ 33 A	S2.2 ■ 14 A	S3.1 ■ 25 A	S3.2 ■ 10 A
S4.1 ■ 20 A	S4.2 ■ 8 A												

DCON MS tolérance h6.

Product	DC (mm)	DCON MS (mm)	APMX (mm)	OAL (mm)	NOF	LU (mm)	DN (mm)
C9206.0	6.00	6.00	24.00	68.0	3	–	–
C9208.0	8.00	10.00	38.00	88.0	4	–	–
C92010.0	10.00	10.00	45.00	95.0	4	54.50	9.50
C92012.0	12.00	12.00	53.00	110.0	4	64.50	11.50
C92014.0	14.00	12.00	53.00	110.0	4	64.50	11.50
C92016.0	16.00	16.00	63.00	123.0	4	74.50	15.50
C92020.0	20.00	20.00	75.00	141.0	4	90.50	19.50
C92025.0	25.00	25.00	90.00	166.0	5	109.50	24.50

C500



Fraise à bout hémisphérique en HSS-E à 2 dents, série extra-courte, finition brillante

Fraise à 2 dents avec une longueur de coupe extra courte offrant une grande rigidité pour une résistance accrue et des vibrations réduites. Géométrie conçue pour le contournage de surfaces complexes sur machines CNC. Convient aux aciers doux, aux matériaux non-ferreux doux et aux alliages de titane de résistance moyenne. Queue détalonnée sur diamètre de coupe supérieur ou égal à 14 mm.

HSS-E	N	NOF 2
	λ 30°	γ 12°
DIN 1835B	Bright	DC e8
	DIN 327D	

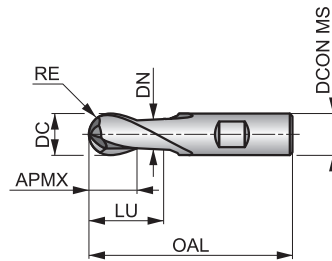

Adéquation du groupe de matériaux de la pièce, valeurs de départ pour la vitesse de coupe (m/min) et code alpha. Tableaux d'avances par dent et facteurs de correction à partir de la page 261.

P1.1 ■ 53 E	P1.2 ■ 59 E	P1.3 ■ 61 E	P2.1 ■ 45 E	P2.2 ■ 40 E	P3.1 ■ 36 E	P3.2 ■ 29 D	P4.1 ■ 22 D	M1.1 ■ 34 E	M1.2 ■ 29 E	M2.1 ■ 31 E	M2.2 ■ 25 D	K1.1 ■ 30 E	K1.2 ■ 22 E
K1.3 ■ 17 E	K2.1 ■ 55 E	K2.2 ■ 45 E	K2.3 ■ 36 D	K3.1 ■ 49 E	K3.2 ■ 37 E	K3.3 ■ 30 D	K4.1 ■ 45 D	K4.2 ■ 34 D	K4.3 ■ 25 D	K4.4 ■ 22 C	K4.5 ■ 18 C	K5.1 ■ 51 D	K5.2 ■ 39 D
K5.3 ■ 30 D	N1.1 ■ 95 G	N1.2 ■ 71 F	N1.3 ■ 48 F	N2.1 ■ 48 E	N2.2 ■ 43 E	N2.3 ■ 31 E	N3.1 ■ 50 E	N3.2 ■ 29 E	N3.3 ■ 15 E	N4.1 ■ 50 E	S1.1 ■ 30 D	S1.2 ■ 25 D	S2.1 ■ 20 C
S3.1 ■ 15 C	S4.1 ■ 12 C												

DCON MS tolérance h6; RE ±0.05 mm.

Product	DC (mm)	RE (mm)	DCON MS (mm)	APMX (mm)	OAL (mm)	NOF	LU (mm)	DN (mm)
C5002.0	2.00	1.00	6.00	4.00	48.0	2	-	-
C5003.0	3.00	1.50	6.00	5.00	49.0	2	-	-
C5004.0	4.00	2.00	6.00	7.00	51.0	2	-	-
C5005.0	5.00	2.50	6.00	8.00	52.0	2	-	-
C5006.0	6.00	3.00	6.00	8.00	52.0	2	-	-
C5007.0	7.00	3.50	10.00	10.00	60.0	2	-	-
C5008.0	8.00	4.00	10.00	11.00	61.0	2	-	-
C50010.0	10.00	5.00	10.00	13.00	63.0	2	-	-
C50012.0	12.00	6.00	12.00	16.00	73.0	2	-	-
C50014.0	14.00	7.00	12.00	16.00	73.0	2	27.50	11.50
C50015.0	15.00	7.50	12.00	16.00	73.0	2	27.50	11.50
C50016.0	16.00	8.00	16.00	19.00	79.0	2	30.50	15.50
C50018.0	18.00	9.00	16.00	19.00	79.0	2	30.50	15.50
C50020.0	20.00	10.00	20.00	22.00	88.0	2	37.50	19.50

C505

DORMER



Fraise à bout hémisphérique en HSS-E à 2 dents, série courte, finition brillante

Fraise à 2 dents avec une longueur de coupe courte offrant une grande rigidité pour une résistance accrue et des vibrations réduites. Géométrie conçue pour le contourage de surfaces complexes sur machines CNC. Convient aux aciers doux, aux matériaux non-ferreux doux et aux alliages de titane de résistance moyenne. Queue détalonnée sur diamètre de coupe égal ou supérieur à 14 mm.

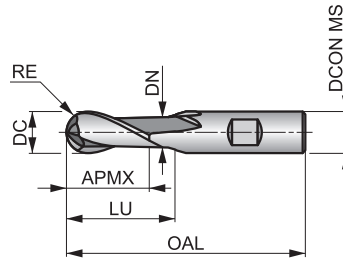

HSS-E	N	NOF 2
	λ 30°	γ 12°
DIN 1835B	Bright	DC e8
	DIN 844K	



Adéquation du groupe de matériaux de la pièce, valeurs de départ pour la vitesse de coupe (m/min) et code alpha. Tableaux d'avances par dent et facteurs de correction à partir de la page 261.

P1.1 ■ 46 D	P1.2 ■ 52 D	P1.3 ■ 54 D	P2.1 ■ 40 D	P2.2 ■ 35 D	P3.1 ■ 32 D	P3.2 ■ 26 C	P4.1 ■ 19 C	M1.1 ■ 34 D	M1.2 ■ 29 D	M2.1 ■ 31 D	M2.2 ■ 25 C	K1.1 ■ 30 D	K1.2 ■ 22 D
K1.3 ■ 17 D	K2.1 ■ 49 D	K2.2 ■ 40 D	K2.3 ■ 32 C	K3.1 ■ 44 D	K3.2 ■ 33 D	K3.3 ■ 27 B	K4.1 ■ 40 C	K4.2 ■ 30 C	K4.3 ■ 22 C	K4.4 ■ 19 B	K4.5 ■ 16 B	K5.1 ■ 46 C	K5.2 ■ 34 C
K5.3 ■ 27 C	N1.1 ■ 81 F	N1.2 ■ 60 E	N1.3 ■ 41 E	N2.1 ■ 41 D	N2.2 ■ 37 D	N2.3 ■ 26 D	N3.1 ■ 43 D	N3.2 ■ 25 D	N3.3 ■ 13 D	N4.1 ■ 43 D	S1.1 ■ 30 C	S1.2 ■ 25 C	S2.1 ■ 20 B
S3.1 ■ 15 B	S4.1 ■ 12 B												

DCON MS tolérance h6; RE ±0.05 mm.

Product	DC (mm)	RE (mm)	DCON MS (mm)	APMX (mm)	OAL (mm)	NOF	LU (mm)	DN (mm)
C5053.0	3.00	1.50	6.00	8.00	52.0	2	–	–
C5054.0	4.00	2.00	6.00	11.00	55.0	2	–	–
C5055.0	5.00	2.50	6.00	13.00	57.0	2	–	–
C5056.0	6.00	3.00	6.00	13.00	57.0	2	–	–
C5058.0	8.00	4.00	10.00	19.00	69.0	2	–	–
C50510.0	10.00	5.00	10.00	22.00	72.0	2	–	–
C50512.0	12.00	6.00	12.00	26.00	83.0	2	–	–
C50514.0	14.00	7.00	12.00	26.00	83.0	2	37.50	11.50
C50516.0	16.00	8.00	16.00	32.00	92.0	2	43.50	15.50
C50520.0	20.00	10.00	20.00	38.00	104.0	2	53.50	19.50
C50522.0	22.00	11.00	20.00	38.00	104.0	2	53.50	19.50
C50530.0	30.00	15.00	25.00	45.00	121.0	2	64.50	24.50

Code de matériau du corps (BMC)	HSS-E	HSS-E	HSS-E	HSS-E						
Profil de fraise	N	N	N	N						
Nombre de goujures (NOF)	NOF 4-5	NOF 10-12	NOF 6-8	NOF 6-12						
Longueur de coupe										
Angle d'hélice de goujure (FHA)	λ 0°	λ 0°	λ 15°	λ 10°						
Angle d'hélice de goujure (FHA)	λ 0°	λ 0°	λ 15°	λ 10°						
Angle de coupe radial (GAMF)	γ 0°	γ 0°	γ 10°	γ 10°						
Queue										
Revêtement	Bright	Bright	Bright	Bright						
Classe de tolérance du diamètre de coupe (TCDC)		DC js16	DC d11	DC h11						
Direction de coupe										
Groupe standard de base (BSG)		DIN 1833C	DIN 851	DIN 850						

Code de famille de produits		C700	C830	C800	C822					
Plage de diamètres de coupe PSF		1.00 – 15.00	12.00 – 32.00	11.00 – 32.00	4.50 – 45.50					
P	P1	■	■	■	■					
	P2	■	■	■	■					
	P3	■	■	■	■					
	P4	■	■	■	■					
M	M1	■	■	■	■					
	M2	■	■	■	■					
	M3	■	■	■	■					
	M4	■	■	■	■					
K	K1	■	■	■	■					
	K2	■	■	■	■					
	K3	■	■	■	■					
	K4	■	■	■	■					
	K5	■	■	■	■					
N	N1	■	■	■	■					
	N2	■	■	■	■					
	N3	■	■	■	■					
	N4		■	■	■					
	N5			■	■					
S	S1	■	■	■	■					
	S2	■	■	■	■					
	S3	■	■	■	■					
	S4	■	■	■	■					
H	H1									
	H2									
	H3									
	H4									

C700



Fraise à rayonner en HSS (1/4 de cercle)

Fraise avec un rayon concave rectifié précis capable de réaliser des rayons d'angle précis autour du périmètre d'un composant. Elle est dotée d'une queue Weldon pour garantir une bonne tenue de l'outil et améliorer l'état de surface du rayon. Finition brillante.

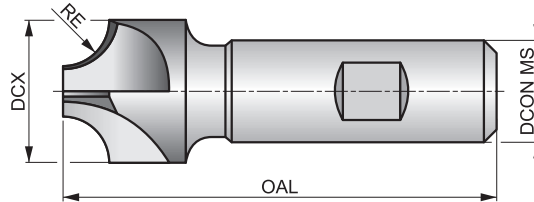

HSS-E	N	NOF 4-5
	λ 0°	γ 0°
DIN 1835B	Bright	
DORMER		



Adéquation du groupe de matériaux de la pièce, valeurs de départ pour la vitesse de coupe (m/min) et code alpha. Tableaux d'avances par dent et facteurs de correction à partir de la page 261.

P1.1 ■ 33 W	P1.2 ■ 37 W	P1.3 ■ 38 W	P2.1 ■ 28 W	P2.2 ■ 25 W	P2.3 ■ 22 W	P3.1 ■ 22 W	P3.2 ■ 18 W	P3.3 ■ 15 W	P4.1 ■ 13 W	P4.2 ■ 11 W	P4.3 ■ 9 W	M1.1 ■ 27 U	M1.2 ■ 23 U
M2.1 ■ 24 U	M2.2 ■ 20 U	M3.1 ■ 17 U	M3.2 ■ 15 U	M3.3 ■ 14 U	M4.1 ■ 10 U	K1.1 ■ 20 W	K1.2 ■ 15 W	K1.3 ■ 11 W	K2.1 ■ 31 W	K2.2 ■ 25 W	K2.3 ■ 20 W	K3.1 ■ 27 W	K3.2 ■ 21 W
K3.3 ■ 17 W	K4.1 ■ 25 U	K4.2 ■ 19 U	K4.3 ■ 14 U	K4.4 ■ 12 U	K4.5 ■ 10 U	K5.1 ■ 29 W	K5.2 ■ 21 W	K5.3 ■ 17 W	N1.1 ■ 57 X	N1.2 ■ 43 X	N1.3 ■ 29 X	N2.1 ■ 29 X	N2.2 ■ 26 X
N2.3 ■ 19 X	N3.1 ■ 30 X	N3.2 ■ 17 X	N3.3 ■ 9 X	S1.1 ■ 25 U	S1.2 ■ 20 U	S1.3 ■ 10 U	S2.1 ■ 13 U	S2.2 ■ 7 U	S3.1 ■ 10 U	S3.2 ■ 5 U	S4.1 ■ 8 U	S4.2 ■ 4 U	

DCON MS tolérance h6.

Product	RE (mm)	DCX (mm)	DCON MS (mm)	OAL (mm)	NOF
C7001.0	1.00	10.00	10.00	60.0	4
C7001.5	1.50	10.00	10.00	60.0	4
C7002.0	2.00	10.00	10.00	60.0	4
C7002.5	2.50	10.00	10.00	60.0	4
C7003.0	3.00	12.00	12.00	60.0	4
C7003.5	3.50	12.00	12.00	60.0	4
C7004.0	4.00	15.00	12.00	60.0	4
C7005.0	5.00	18.00	16.00	70.0	4
C7006.0	6.00	21.00	16.00	70.0	4
C7007.0	7.00	24.00	16.00	70.0	4
C7008.0	8.00	24.00	16.00	70.0	4
C7009.0	9.00	28.00	20.00	85.0	4
C70010.0	10.00	28.00	20.00	85.0	4
C70012.0	12.00	35.00	20.00	100.0	4
C70012.5	12.50	35.00	20.00	100.0	4
C70015.0	15.00	48.00	25.00	105.0	5

C830

DORMER



Fraise à queue d'aronde en HSS-E

Fraise conçue avec des angles de 45° et 60° avec une queue Weldon pour un maintien précis et stable. Convient aux formes courantes en queue d'aronde. La finition brillante empêche le matériau de la pièce de coller aux arêtes de coupe de l'outil.

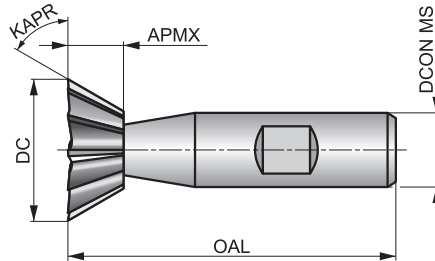

HSS-E	N	NOF 10-12
λ 0°	γ 0°	DIN 1835B
Bright	DC js16	
DIN 1833C		

Adéquation du groupe de matériaux de la pièce, valeurs de départ pour la vitesse de coupe (m/min) et code alpha. Tableaux d'avances par dent et facteurs de correction à partir de la page 261.

P1.1 ■ 33 Y	P1.2 ■ 37 Y	P1.3 ■ 38 Y	P2.1 ■ 28 Y	P2.2 ■ 25 X	P2.3 ■ 22 X	P3.1 ■ 22 X	P3.2 ■ 18 X	P3.3 ■ 15 X	P4.1 ■ 13 X	P4.2 ■ 11 X	P4.3 ■ 9 X	M1.1 ■ 27 W	M1.2 ■ 23 W
M2.1 ■ 24 W	M2.2 ■ 20 W	M3.1 ■ 17 W	M3.2 ■ 15 W	M3.3 ■ 14 W	M4.1 ■ 10 W	K1.1 ■ 20 Y	K1.2 ■ 15 Y	K1.3 ■ 11 Y	K2.1 ■ 31 X	K2.2 ■ 25 X	K2.3 ■ 20 X	K3.1 ■ 27 X	K3.2 ■ 21 X
K3.3 ■ 17 X	K4.1 ■ 25 W	K4.2 ■ 19 W	K4.3 ■ 14 W	K4.4 ■ 12 W	K4.5 ■ 10 W	K5.1 ■ 29 X	K5.2 ■ 21 X	K5.3 ■ 17 X	N1.1 ■ 59 Z	N1.2 ■ 44 Z	N1.3 ■ 30 Z	N2.1 ■ 30 Z	N2.2 ■ 27 Z
N2.3 ■ 19 Z	N3.1 ■ 31 Y	N3.2 ■ 18 Y	N3.3 ■ 9 Z	N4.1 ■ 31 Z	S1.1 ■ 25 Y	S1.2 ■ 15 Y	S1.3 ■ 10 X	S2.1 ■ 13 W	S2.2 ■ 7 W	S3.1 ■ 10 W	S3.2 ■ 5 W	S4.1 ■ 8 W	S4.2 ■ 4 W

DCON MS tolérance h6.

Product	KAPR (°)	APMX (mm)	DC (mm)	OAL (mm)	DCON MS (mm)	NOF
C83012.0X45	45	3.50	12.00	54.0	10.00	10
C83016.0X45	45	4.00	16.00	60.0	12.00	10
C83020.0X45	45	5.00	20.00	63.0	12.00	10
C83025.0X45	45	6.30	25.00	67.0	12.00	10
C83032.0X45	45	8.00	32.00	71.0	16.00	12
C83012.0X60	60	5.00	12.00	54.0	10.00	10
C83016.0X60	60	6.30	16.00	60.0	12.00	10
C83020.0X60	60	8.00	20.00	63.0	12.00	10
C83025.0X60	60	10.00	25.00	67.0	12.00	10
C83032.0X60	60	12.50	32.00	71.0	16.00	12

C800

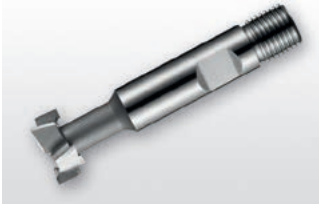

Fraise à rainurer en T en HSS

Fraise convenant pour le fraisage de rainures en T permettant d'accepter des boulons en T standards. Elle possède une queue combinée pour un maintien précis et stable dans tous les types de porte-outils. La finition brillante empêche le matériau de la pièce de coller aux arêtes de coupe de l'outil.

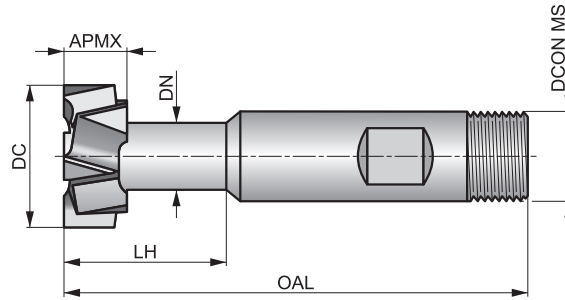

HSS-E	N	NOF 6-8
λ 15°	γ 10°	DIN 1835
Bright	DC d11	
DIN 851		



Adéquation du groupe de matériaux de la pièce, valeurs de départ pour la vitesse de coupe (m/min) et code alpha. Tableaux d'avances par dent et facteurs de correction à partir de la page 261.

P1.1 ■ 40V	P1.2 ■ 45V	P1.3 ■ 46V	P2.1 ■ 34V	P2.2 ■ 30U	P2.3 ■ 27T	P3.1 ■ 29U	P3.2 ■ 24U	P3.3 ■ 20T	P4.1 ■ 18U	P4.2 ■ 15T	P4.3 ■ 12T	M1.1 ■ 27S	M1.2 ■ 23S
M2.1 ■ 24S	M2.2 ■ 20S	M3.1 ■ 17S	M3.2 ■ 15S	M3.3 ■ 14S	M4.1 ■ 10S	K1.1 ■ 20V	K1.2 ■ 15V	K1.3 ■ 11V	K2.1 ■ 37U	K2.2 ■ 30U	K2.3 ■ 24U	K3.1 ■ 33U	K3.2 ■ 25U
K3.3 ■ 20U	K4.1 ■ 30S	K4.2 ■ 23S	K4.3 ■ 17S	K4.4 ■ 14S	K4.5 ■ 12S	K5.1 ■ 34U	K5.2 ■ 26U	K5.3 ■ 20U	N1.1 ■ 71Y	N1.2 ■ 53Y	N1.3 ■ 36Y	N2.1 ■ 36Y	N2.2 ■ 32Y
N2.3 ■ 23Y	N3.1 ■ 38V	N3.2 ■ 22V	N3.3 ■ 11W	N4.1 ■ 38Y	S1.1 ■ 30V	S1.2 ■ 20V	S1.3 ■ 10U	S2.1 ■ 13U	S2.2 ■ 7T	S3.1 ■ 10U	S3.2 ■ 5T	S4.1 ■ 8U	S4.2 ■ 4T

DCON MS tolérance h6.

Product	APMX (mm)	DC (mm)	T DIN650	DN (mm)	LH (mm)	OAL (mm)	DCON MS (mm)	NOF
C80011.0X5.0	4.00	11.00	5	4.00	10.5	53.5	10.00	6
C80012.5X6.0	6.00	12.50	6	5.00	15.0	57.0	10.00	6
C80016.0X8.0	8.00	16.00	8	7.00	20.0	62.0	10.00	6
C80018.0X10.0	8.00	18.00	10	8.00	23.0	70.0	12.00	6
C80021.0X12.0	9.00	21.00	12	10.00	27.0	74.0	12.00	8
C80025.0X14.0	11.00	25.00	14	12.00	31.0	82.0	16.00	8
C80032.0X18.0	14.00	32.00	18	15.00	40.0	90.0	16.00	8

C822



Fraise Woodruff en HSS-E

Fraise convenant pour le fraisage des clavettes demi-lune (Woodruff) dans les broches et les arbres. La queue combinée permet un maintien stable et précis dans tous les types de supports. La finition brillante empêche le matériau de la pièce de coller aux arêtes de coupe de l'outil.

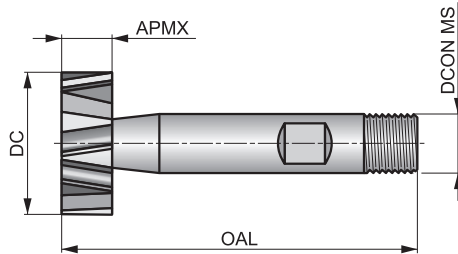

HSS-E	N	NOF 6-12
λ 10°	γ 10°	DIN 1835
Bright	DC h11	
DIN 850		



Adéquation du groupe de matériaux de la pièce, valeurs de départ pour la vitesse de coupe (m/min) et code alpha. Tableaux d'avances par dent et facteurs de correction à partir de la page 261.

P1.1 ■ 40V	P1.2 ■ 45V	P1.3 ■ 46V	P2.1 ■ 34V	P2.2 ■ 30U	P2.3 ■ 27T	P3.1 ■ 29U	P3.2 ■ 24U	P3.3 ■ 20T	P4.1 ■ 18U	P4.2 ■ 15T	P4.3 ■ 12T	M1.1 ■ 34S	M1.2 ■ 29S
M2.1 ■ 31S	M2.2 ■ 25S	M3.1 ■ 17S	M3.2 ■ 15S	M3.3 ■ 14S	M4.1 ■ 15S	K1.1 ■ 25V	K1.2 ■ 19V	K1.3 ■ 14V	K2.1 ■ 37U	K2.2 ■ 30U	K2.3 ■ 24U	K3.1 ■ 33U	K3.2 ■ 25U
K3.3 ■ 20U	K4.1 ■ 30S	K4.2 ■ 23S	K4.3 ■ 17S	K4.4 ■ 14S	K4.5 ■ 12S	K5.1 ■ 34U	K5.2 ■ 26U	K5.3 ■ 20U	N1.1 ■ 71Y	N1.2 ■ 53Y	N1.3 ■ 36Y	N2.1 ■ 36Y	N2.2 ■ 32Y
N2.3 ■ 23Y	N3.1 ■ 38V	N3.2 ■ 22V	N3.3 ■ 11W	N4.1 ■ 38Y	S1.1 ■ 30V	S1.2 ■ 20V	S1.3 ■ 10U	S2.1 ■ 13U	S2.2 ■ 7T	S3.1 ■ 10U	S3.2 ■ 5T	S4.1 ■ 8U	S4.2 ■ 4T

DCON MS tolérance h6.

Product	APMX (mm)	DC (mm)	OAL (mm)	DCON MS (mm)	NOF
C8224.5X1.0	1.00	4.50	50.0	6.00	6
C8227.5X1.5	1.50	7.50	50.0	6.00	6
C8227.5X2.0	2.00	7.50	50.0	6.00	6
C82210.5X2.0	2.00	10.50	50.0	6.00	8
C82210.5X2.5	2.50	10.50	50.0	6.00	8
C82210.5X3.0	3.00	10.50	50.0	6.00	8
C82213.5X3.0	3.00	13.50	56.0	10.00	8
C82213.5X4.0	4.00	13.50	56.0	10.00	8
C82216.5X3.0	3.00	16.50	56.0	10.00	8
C82216.5X4.0	4.00	16.50	56.0	10.00	8
C82216.5X5.0	5.00	16.50	56.0	10.00	8
C82219.5X3.0	3.00	19.50	63.0	10.00	10
C82219.5X4.0	4.00	19.50	63.0	10.00	10
C82219.5X5.0	5.00	19.50	63.0	10.00	10
C82222.5X5.0	5.00	22.50	63.0	10.00	10
C82222.5X6.0	6.00	22.50	63.0	10.00	10
C82222.5X8.0	8.00	22.50	63.0	10.00	10
C82225.5X6.0	6.00	25.50	63.0	10.00	12
C82228.5X6.0	6.00	28.50	63.0	10.00	12
C82228.5X8.0	8.00	28.50	63.0	10.00	12
C82228.5X10.0	10.00	28.50	71.0	12.00	12
C82232.5X8.0	8.00	32.50	71.0	12.00	12
C82232.5X10.0	10.00	32.50	71.0	12.00	12
C82245.5X10.0	10.00	45.50	71.0	12.00	12

Code de matériau du corps (BMC)		HSS	HSS	HSS	HSS	HSS	HSS
Profil de fraise							
Nombre de goujures (NOF)							
Angle d'hélice de goujure (FHA)							
Angle d'hélice de goujure (FHA)							
Angle de coupe radial (GAMF)		γ 15°	γ 5°	γ 18°	γ 18°	γ 18°	γ 18°
Revêtement		Bright	Bright	ST	ST	ST	ST
Classe de tolérance du diamètre de coupe (TCDC)							
Direction de coupe							
Groupe standard de base (BSG)		DIN 1838	DIN 1837	DORMER	DORMER	DORMER	DORMER
Code de famille de produits		D745	D747	D750	D751	D752	D753
Plage de diamètres de coupe PSF		50.00 – 250.00	32.00 – 200.00	200.00 – 350.00	200.00 – 350.00	250.00 – 350.00	250.00 – 350.00
		56	58	60	61	62	63
P	P1	■	■	■	■	■	■
	P2	■	■	■	■	■	■
	P3	■	■	■	■	■	■
	P4	■	■	■	■	■	■
M	M1	▣	▣	▣	▣	▣	▣
	M2	▣	▣	▣	▣	▣	▣
	M3	▣	▣	▣	▣	▣	▣
	M4						
K	K1	■	■	■	■	■	■
	K2	■	■	■	■	■	■
	K3	■	■	■	■	■	■
	K4	■	■	■	■	■	■
	K5	■	■	■	■	■	■
N	N1	■	■	■	■	■	■
	N2	■	■	■	■	■	■
	N3	■	■	■	■	■	■
	N4	■	■	■	■	■	■
	N5						
S	S1						
	S2						
	S3						
	S4						
H	H1						
	H2						
	H3						
	H4						

HSS-E	HSS-E	HSS-E	HSS-E
	N	N	NR
λ 15°	λ 30°	λ 30°	λ 30°
λ 15°	λ 30°	λ 30°	λ 30°
γ 10°	γ 12°	γ 12°	γ 12°
Bright	Bright	TiCN	Bright
DC js16	DC js16	DC js16	DC js16
DIN 885A	DIN 1880	DIN 1880	DIN 1880



D763	D400	D420	D402
------	------	------	------

63.00 – 125.00	40.00 – 50.00	63.00	63.00
----------------	---------------	-------	-------

64	65	66	67
----	----	----	----

P1	■	■	■				
P2	■	■	■	■			
P3	■	■	■	■			
P4	■	▣	■	▣			
M1	■	■	■	■			
M2	■	■	■	■			
M3	■	▣	■	▣			
M4	■	■	■	■			
K1	■	■	■	■			
K2	■	■	■	■			
K3	■	■	■	■			
K4	■	■	■	■			
K5	■	■	■	■			
N1	■	▣	▣	▣			
N2	■	■	■	■			
N3	■	■	■	■			
N4	■	▣	▣	▣			
N5							
S1	■	▣	■	▣			
S2	■	▣	■	▣			
S3	■	▣	■	▣			
S4	■	▣	■	▣			
H1							
H2							
H3							
H4							

D745

DORMER



Fraise scie en HSS à pas gros

Fraise conçue avec un pas gros, idéale pour réaliser des ouvertures étroites et profondes. La géométrie de la denture parabolique et neutre permet de contrôler les copeaux et d'éviter le frottement lors du fraisage de rainures profondes. Convient pour le fraisage horizontal de rainures et les applications de tronçonnage. Finition brillante.

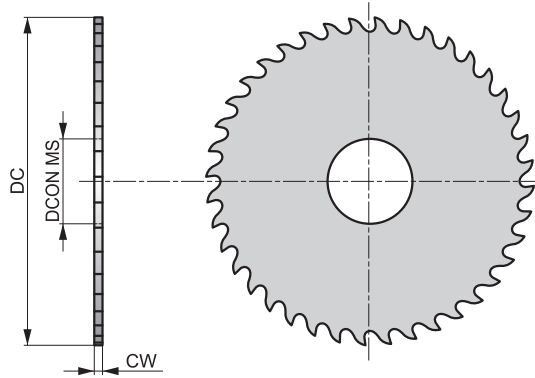

HSS		γ 15°
Bright	DIN 1838	



Adéquation du groupe de matériaux de la pièce, valeurs de départ pour la vitesse de coupe (m/min) et code alpha. Tableaux d'avances par dent et facteurs de correction à partir de la page 261.

P1.1 ■ 40 Q	P1.2 ■ 45 Q	P1.3 ■ 46 Q	P2.1 ■ 34 Q	P2.2 ■ 30 Q	P3.1 ■ 29 P	P3.2 ■ 24 P	P4.1 ■ 18 P	M1.1 ▣ 14 P	M1.2 ▣ 12 P	M2.1 ▣ 12 P	M2.2 ▣ 10 P	M3.1 ▣ 12 P	M3.2 ▣ 10 P
K1.1 ■ 40 Q	K1.2 ■ 30 Q	K1.3 ■ 22 Q	K2.1 ■ 37 Q	K2.2 ■ 30 Q	K3.1 ■ 33 Q	K3.2 ■ 25 Q	K4.1 ■ 30 P	K4.2 ■ 23 P	K5.1 ■ 34 Q	K5.2 ■ 26 Q	N1.1 ■ 600 R	N1.2 ■ 450 R	N1.3 ■ 300 R
N2.1 ■ 769 R	N2.2 ■ 692 R	N2.3 ■ 500 R	N3.1 ■ 339 R	N3.2 ■ 200 R	N3.3 ■ 100 Q	N4.1 ■ 60 R							

Product	DC	CW	DCON MS	NOF
	(mm)	(mm)	(mm)	
D74550.0X.5	50.00	0.5	13.00	48
D74550.0X.8	50.00	0.8	13.00	40
D74550.0X1.0	50.00	1.0	13.00	40
D74550.0X1.2	50.00	1.2	13.00	40
D74550.0X1.5	50.00	1.5	13.00	32
D74550.0X1.6	50.00	1.6	13.00	32
D74550.0X2.0	50.00	2.0	13.00	32
D74563.0X.5	63.00	0.5	16.00	64
D74563.0X.6	63.00	0.6	16.00	48
D74563.0X.8	63.00	0.8	16.00	48
D74563.0X1.0	63.00	1.0	16.00	48
D74563.0X1.2	63.00	1.2	16.00	40
D74563.0X1.5	63.00	1.5	16.00	40
D74563.0X1.6	63.00	1.6	16.00	40
D74563.0X2.0	63.00	2.0	16.00	40
D74580.0X1.0	80.00	1.0	22.00	48
D74580.0X1.2	80.00	1.2	22.00	48
D74580.0X1.5	80.00	1.5	22.00	48
D74580.0X1.6	80.00	1.6	22.00	48
D74580.0X2.0	80.00	2.0	22.00	40
D74580.0X2.5	80.00	2.5	22.00	40
D74580.0X3.0	80.00	3.0	22.00	40
D745100.0X1.0	100.00	1.0	22.00	64
D745100.0X1.2	100.00	1.2	22.00	64
D745100.0X1.5	100.00	1.5	22.00	48
D745100.0X1.6	100.00	1.6	22.00	48
D745100.0X2.0	100.00	2.0	22.00	48
D745100.0X2.5	100.00	2.5	22.00	48

Product	DC	CW	DCON MS	NOF
	(mm)	(mm)	(mm)	
D745100.0X3.0	100.00	3.0	22.00	40
D745100.0X4.0	100.00	4.0	22.00	40
D745125.0X1.0	125.00	1.0	22.00	80
D745125.0X1.2	125.00	1.2	22.00	64
D745125.0X1.5	125.00	1.5	22.00	64
D745125.0X1.6	125.00	1.6	22.00	64
D745125.0X2.0	125.00	2.0	22.00	64
D745125.0X2.5	125.00	2.5	22.00	48
D745125.0X3.0	125.00	3.0	22.00	48
D745160.0X2.0	160.00	2.0	32.00	64
D745160.0X2.5	160.00	2.5	32.00	64
D745160.0X3.0	160.00	3.0	32.00	64
D745200.0X1.6	200.00	1.6	32.00	80
D745200.0X2.0	200.00	2.0	32.00	80
D745200.0X2.5	200.00	2.5	32.00	80
D745200.0X3.0	200.00	3.0	32.00	64
D745250.0X2.0	250.00	2.0	32.00	100

D747



Fraise scie en HSS à pas fin

Fraise conçue avec une géométrie de dents neutre pour faciliter le contrôle des copeaux et éviter les frottements lors du fraisage de rainures profondes. La conception à pas fin est idéale pour les rainures étroites et profondes et peut être utilisée pour le fraisage horizontal de rainures et les applications de tronçonnage. Finition brillante.

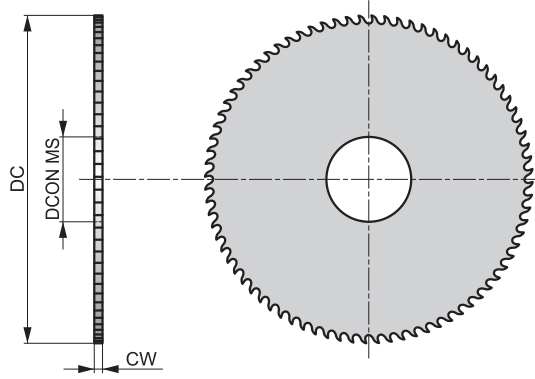

HSS		γ 5°
Bright	DIN 1837	



Adéquation du groupe de matériaux de la pièce, valeurs de départ pour la vitesse de coupe (m/min) et code alpha. Tableaux d'avances par dent et facteurs de correction à partir de la page 261.

P1.1 ■ 40 Q	P1.2 ■ 45 Q	P1.3 ■ 46 Q	P2.1 ■ 34 Q	P2.2 ■ 30 Q	P3.1 ■ 29 P	P3.2 ■ 24 P	P4.1 ■ 18 P	M1.1 ▣ 14 P	M1.2 ▣ 12 P	M2.1 ▣ 12 P	M2.2 ▣ 10 P	M3.1 ▣ 12 P	M3.2 ▣ 10 P
K1.1 ■ 40 Q	K1.2 ■ 30 Q	K1.3 ■ 22 Q	K2.1 ■ 37 Q	K2.2 ■ 30 Q	K3.1 ■ 33 Q	K3.2 ■ 25 Q	K4.1 ■ 30 P	K4.2 ■ 23 P	K5.1 ■ 34 Q	K5.2 ■ 26 Q	N1.1 ■ 600 R	N1.2 ■ 450 R	N1.3 ■ 300 R
N2.1 ■ 769 R	N2.2 ■ 692 R	N2.3 ■ 500 R	N3.1 ■ 339 R	N3.2 ■ 200 R	N3.3 ■ 100 Q	N4.1 ■ 60 R							

Product	DC	CW	DCON MS	NOF
	(mm)	(mm)	(mm)	
D74732.0X.3	32.00	0.3	8.00	80
D74732.0X.4	32.00	0.4	8.00	80
D74732.0X.5	32.00	0.5	8.00	80
D74732.0X.6	32.00	0.6	8.00	64
D74732.0X.8	32.00	0.8	8.00	64
D74732.0X1.0	32.00	1.0	8.00	64
D74732.0X1.2	32.00	1.2	8.00	48
D74732.0X1.5	32.00	1.5	8.00	48
D74732.0X1.6	32.00	1.6	8.00	48
D74732.0X2.0	32.00	2.0	8.00	48
D74740.0X.3	40.00	0.3	10.00	100
D74740.0X.4	40.00	0.4	10.00	100
D74740.0X.5	40.00	0.5	10.00	80
D74740.0X.8	40.00	0.8	10.00	80
D74740.0X1.0	40.00	1.0	10.00	64
D74740.0X1.2	40.00	1.2	10.00	64
D74740.0X1.5	40.00	1.5	10.00	64
D74740.0X1.6	40.00	1.6	10.00	64
D74740.0X2.0	40.00	2.0	10.00	48
D74750.0X.3	50.00	0.3	13.00	128
D74750.0X.4	50.00	0.4	13.00	100
D74750.0X.5	50.00	0.5	13.00	100
D74750.0X.6	50.00	0.6	13.00	100
D74750.0X.8	50.00	0.8	13.00	80
D74750.0X1.0	50.00	1.0	13.00	80
D74750.0X1.2	50.00	1.2	13.00	80
D74750.0X1.5	50.00	1.5	13.00	64
D74750.0X1.6	50.00	1.6	13.00	64



Product	DC	CW	DCON MS	NOF
	(mm)	(mm)	(mm)	
D74750.0X2.0	50.00	2.0	13.00	64
D74750.0X2.5	50.00	2.5	13.00	64
D74750.0X3.0	50.00	3.0	13.00	48
D74763.0X.5	63.00	0.5	16.00	128
D74763.0X.6	63.00	0.6	16.00	100
D74763.0X.8	63.00	0.8	16.00	100
D74763.0X1.0	63.00	1.0	16.00	100
D74763.0X1.2	63.00	1.2	16.00	80
D74763.0X1.5	63.00	1.5	16.00	80
D74763.0X1.6	63.00	1.6	16.00	80
D74763.0X2.0	63.00	2.0	16.00	80
D74763.0X2.5	63.00	2.5	16.00	64
D74763.0X3.0	63.00	3.0	16.00	64
D74763.0X4.0	63.00	4.0	16.00	64
D74780.0X.5	80.00	0.5	22.00	128
D74780.0X.6	80.00	0.6	22.00	128
D74780.0X.8	80.00	0.8	22.00	128
D74780.0X1.0	80.00	1.0	22.00	100
D74780.0X1.2	80.00	1.2	22.00	100
D74780.0X1.5	80.00	1.5	22.00	100
D74780.0X1.6	80.00	1.6	22.00	100
D74780.0X2.0	80.00	2.0	22.00	80
D74780.0X2.5	80.00	2.5	22.00	80
D74780.0X3.0	80.00	3.0	22.00	80
D74780.0X4.0	80.00	4.0	22.00	64
D747100.0X.5	100.00	0.5	22.00	160
D747100.0X.6	100.00	0.6	22.00	160
D747100.0X.8	100.00	0.8	22.00	128
D747100.0X1.0	100.00	1.0	22.00	128
D747100.0X1.2	100.00	1.2	22.00	128
D747100.0X1.5	100.00	1.5	22.00	100
D747100.0X1.6	100.00	1.6	22.00	100
D747100.0X2.0	100.00	2.0	22.00	100
D747100.0X2.5	100.00	2.5	22.00	100
D747100.0X3.0	100.00	3.0	22.00	80
D747100.0X4.0	100.00	4.0	22.00	80
D747125.0X1.0	125.00	1.0	22.00	160
D747125.0X1.2	125.00	1.2	22.00	128
D747125.0X1.5	125.00	1.5	22.00	128
D747125.0X1.6	125.00	1.6	22.00	128
D747125.0X2.0	125.00	2.0	22.00	128
D747125.0X2.5	125.00	2.5	22.00	100
D747125.0X3.0	125.00	3.0	22.00	100
D747125.0X4.0	125.00	4.0	22.00	100
D747160.0X1.0	160.00	1.0	32.00	160
D747160.0X1.2	160.00	1.2	32.00	160
D747160.0X1.5	160.00	1.5	32.00	160
D747160.0X2.0	160.00	2.0	32.00	128
D747160.0X2.5	160.00	2.5	32.00	128
D747160.0X3.0	160.00	3.0	32.00	128
D747200.0X1.0	200.00	1.0	32.00	200
D747200.0X1.2	200.00	1.2	32.00	200
D747200.0X2.0	200.00	2.0	32.00	160
D747200.0X3.0	200.00	3.0	32.00	128

D750

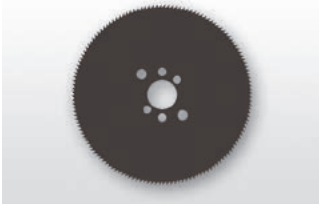

Fraise scie en HSS à pas fin

Fraise conçue avec un pas fin, idéale pour les pièces à section fine. Convient pour la coupe et la découpe. Avec des gammes de 130 à 220 dents, la géométrie neutre des dents permet de contrôler les copeaux et d'éviter les frottements lors de la coupe de tubes et de tuyaux. La finition traitée vapeur retient le liquide de coupe et empêche le collage des copeaux à l'outil.

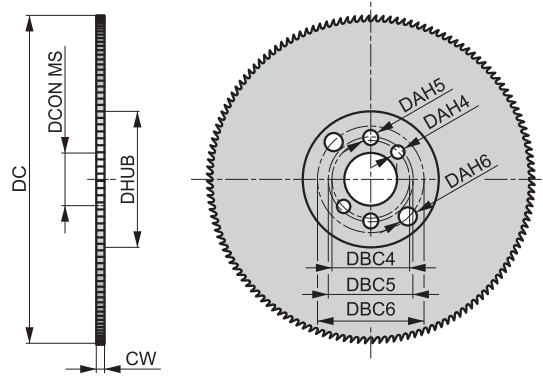

HSS

 γ 18°



Adéquation du groupe de matériaux de la pièce, valeurs de départ pour la vitesse de coupe (m/min) et code alpha. Tableaux d'avances par dent et facteurs de correction à partir de la page 261.

P1.1 ■ 40 Q	P1.2 ■ 45 Q	P1.3 ■ 46 Q	P2.1 ■ 34 Q	P2.2 ■ 30 Q	P3.1 ■ 29 P	P3.2 ■ 24 P	P4.1 ■ 18 P	M1.1 ▣ 14 P	M1.2 ▣ 12 P	M2.1 ▣ 12 P	M2.2 ▣ 10 P	M3.1 ▣ 12 P	M3.2 ▣ 10 P
K1.1 ■ 40 Q	K1.2 ■ 30 Q	K1.3 ■ 22 Q	K2.1 ■ 37 Q	K2.2 ■ 30 Q	K3.1 ■ 33 Q	K3.2 ■ 25 Q	K4.1 ■ 30 P	K4.2 ■ 23 P	K5.1 ■ 34 Q	K5.2 ■ 26 Q	N1.1 ■ 600 R	N1.2 ■ 450 R	N1.3 ■ 300 R
N2.1 ■ 769 R	N2.2 ■ 692 R	N2.3 ■ 500 R	N3.1 ■ 339 R	N3.2 ■ 200 R	N3.3 ■ 100 Q	N4.1 ■ 60 R							

Product	DC (mm)	CW (mm)	DCON MS (mm)	NOF	P (mm)	DHUB (mm)	DAH4 (mm)	DBC4 (mm)	DAH5 (mm)	DBC5 (mm)	DAH6 (mm)	DBC6 (mm)
D750200.0X1.8	200.00	1.8	32.00	130	5	100	8	45	9	50	11	63
D750225.0X2.0	225.00	2.0	32.00	140	5	100	8	45	9	50	11	63
D750250.0X2.0	250.00	2.0	32.00	160	5	100	8	45	9	50	11	63
D750275.0X2.5	275.00	2.5	32.00	180	5	100	8	45	9	50	11	63
D750300.0X2.5	300.00	2.5	32.00	180	5	100	8	45	9	50	11	63
D750315.0X2.5	315.00	2.5	32.00	200	5	100	8	45	9	50	11	63
D750350.0X2.5	350.00	2.5	32.00	220	5	120	8	45	9	59	11	63

D751

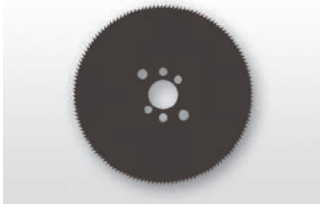

Fraise scie en HSS à pas fin

Fraise conçue avec un pas fin, idéale pour les pièces à section fine. Convient pour la coupe et la découpe. Avec des gammes de 160 à 350 dents, la géométrie neutre des dents permet de contrôler les copeaux et d'éviter les frottements lors de la coupe de tubes et de tuyaux. La finition traitée vapeur retient le liquide de coupe et empêche le collage des copeaux à l'outil.

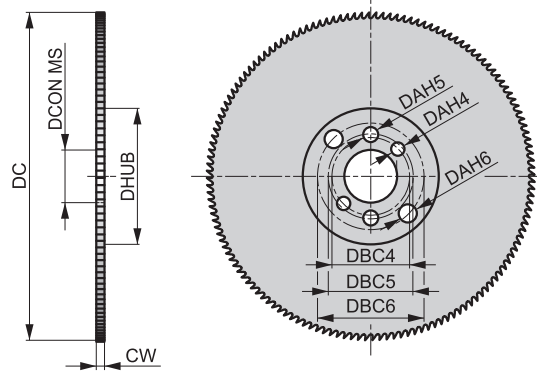

HSS
 γ 18°



Adéquation du groupe de matériaux de la pièce, valeurs de départ pour la vitesse de coupe (m/min) et code alpha. Tableaux d'avances par dent et facteurs de correction à partir de la page 261.

P1.1 ■ 40 Q	P1.2 ■ 45 Q	P1.3 ■ 46 Q	P2.1 ■ 34 Q	P2.2 ■ 30 Q	P3.1 ■ 29 P	P3.2 ■ 24 P	P4.1 ■ 18 P	M1.1 ▣ 14 P	M1.2 ▣ 12 P	M2.1 ▣ 12 P	M2.2 ▣ 10 P	M3.1 ▣ 12 P	M3.2 ▣ 10 P
K1.1 ■ 40 Q	K1.2 ■ 30 Q	K1.3 ■ 22 Q	K2.1 ■ 37 Q	K2.2 ■ 30 Q	K3.1 ■ 33 Q	K3.2 ■ 25 Q	K4.1 ■ 30 P	K4.2 ■ 23 P	K5.1 ■ 34 Q	K5.2 ■ 26 Q	N1.1 ■ 600 R	N1.2 ■ 450 R	N1.3 ■ 300 R
N2.1 ■ 769 R	N2.2 ■ 692 R	N2.3 ■ 500 R	N3.1 ■ 339 R	N3.2 ■ 200 R	N3.3 ■ 100 Q	N4.1 ■ 60 R							

Product	DC (mm)	CW (mm)	DCON MS (mm)	NOF	P (mm)	DHUB (mm)	DAH4 (mm)	DBC4 (mm)	DAH5 (mm)	DBC5 (mm)	DAH6 (mm)	DBC6 (mm)
D751200.0X1.8X160	200.00	1.8	32.00	160	4	100	8	45	9	50	11	63
D751200.0X1.8X200	200.00	1.8	32.00	200	3	100	8	45	9	50	11	63
D751225.0X2.0X180	225.00	2.0	32.00	180	4	100	8	45	9	50	11	63
D751225.0X2.0X220	225.00	2.0	32.00	220	3	100	8	45	9	50	11	63
D751250.0X2.0X200	250.00	2.0	32.00	200	4	100	8	45	9	50	11	63
D751250.0X2.0X250	250.00	2.0	32.00	250	3	100	8	45	9	50	11	63
D751275.0X2.5X220	275.00	2.5	32.00	220	4	100	8	45	9	50	11	63
D751300.0X2.5X220	300.00	2.5	32.00	220	4	100	8	45	9	50	11	63
D751300.0X2.5X300	300.00	2.5	32.00	300	3	100	8	45	9	50	11	63
D751315.0X2.5X240	315.00	2.5	32.00	240	4	100	8	45	9	50	11	63
D751350.0X2.5X280	350.00	2.5	32.00	280	4	120	8	45	9	50	11	63
D751350.0X2.5X350	350.00	2.5	32.00	350	3	120	8	45	9	50	11	63

D752

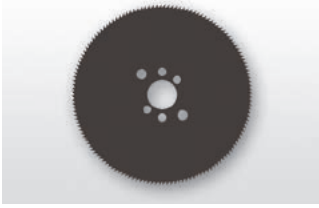

Fraise scie en HSS à pas gros

Fraise conçue avec un pas gros, idéale pour les pièces à section fine. La géométrie de la denture parabolique et neutre, en plus d'aider à contrôler les copeaux, empêche également le frottement lors de la coupe de tubes et de tuyaux. Convient pour la coupe et la découpe. La finition traitée vapeur retient le liquide de coupe et empêche le collage des copeaux à l'outil.

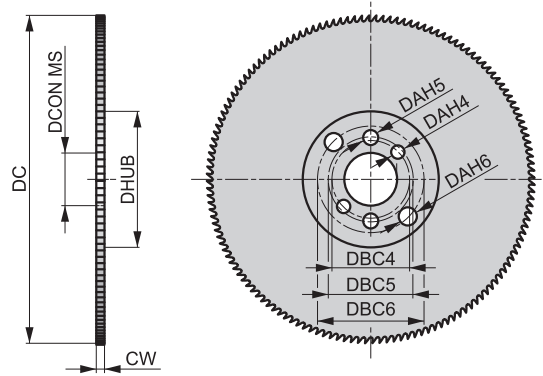

HSS		γ 18°
ST		



Adéquation du groupe de matériaux de la pièce, valeurs de départ pour la vitesse de coupe (m/min) et code alpha. Tableaux d'avances par dent et facteurs de correction à partir de la page 261.

P1.1 ■ 40 Q	P1.2 ■ 45 Q	P1.3 ■ 46 Q	P2.1 ■ 34 Q	P2.2 ■ 30 Q	P3.1 ■ 29 P	P3.2 ■ 24 P	P4.1 ■ 18 P	M1.1 ▣ 14 P	M1.2 ▣ 12 P	M2.1 ▣ 12 P	M2.2 ▣ 10 P	M3.1 ▣ 12 P	M3.2 ▣ 10 P
K1.1 ■ 40 Q	K1.2 ■ 30 Q	K1.3 ■ 22 Q	K2.1 ■ 37 Q	K2.2 ■ 30 Q	K3.1 ■ 33 Q	K3.2 ■ 25 Q	K4.1 ■ 30 P	K4.2 ■ 23 P	K5.1 ■ 34 Q	K5.2 ■ 26 Q	N1.1 ■ 600 R	N1.2 ■ 450 R	N1.3 ■ 300 R
N2.1 ■ 769 R	N2.2 ■ 692 R	N2.3 ■ 500 R	N3.1 ■ 339 R	N3.2 ■ 200 R	N3.3 ■ 100 Q	N4.1 ■ 60 R							

Product	DC (mm)	CW (mm)	DCON MS (mm)	NOF	P (mm)	DHUB (mm)	DAH4 (mm)	DBC4 (mm)	DAH5 (mm)	DBC5 (mm)	DAH6 (mm)	DBC6 (mm)
D752250.0X2.0X128	250.00	2.0	32.00	128	6	100	8	45	9	50	11	63
D752300.0X2.5X160	300.00	2.5	32.00	160	6	100	8	45	9	50	11	63
D752315.0X2.5X160	315.00	2.5	32.00	160	6	100	8	45	9	50	11	63
D752350.0X2.5X180	350.00	2.5	32.00	180	6	120	8	45	9	50	11	63

D753



Fraise scie en HSS à pas gros

Fraise conçue avec un pas gros, idéale pour les pièces à section fine. La géométrie de la denture parabolique et neutre, en plus d'aider à contrôler les copeaux, empêche également le frottement lors de la coupe de tubes et de tuyaux. Convient pour la coupe et la découpe. La finition traitée vapeur retient le liquide de coupe et empêche le collage des copeaux à l'outil.

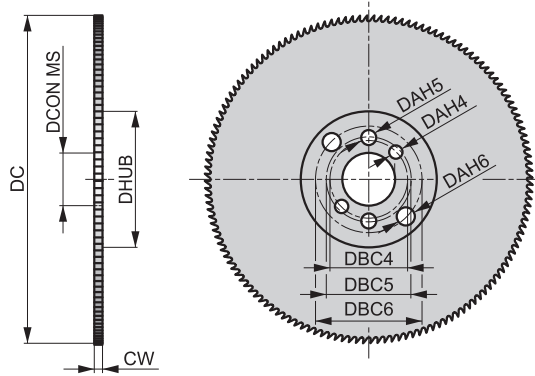

HSS
 γ 18°



Adéquation du groupe de matériaux de la pièce, valeurs de départ pour la vitesse de coupe (m/min) et code alpha. Tableaux d'avances par dent et facteurs de correction à partir de la page 261.

P1.1 ■ 40 Q	P1.2 ■ 45 Q	P1.3 ■ 46 Q	P2.1 ■ 34 Q	P2.2 ■ 30 Q	P3.1 ■ 29 P	P3.2 ■ 24 P	P4.1 ■ 18 P	M1.1 ▣ 14 P	M1.2 ▣ 12 P	M2.1 ▣ 12 P	M2.2 ▣ 10 P	M3.1 ▣ 12 P	M3.2 ▣ 10 P
K1.1 ■ 40 Q	K1.2 ■ 30 Q	K1.3 ■ 22 Q	K2.1 ■ 37 Q	K2.2 ■ 30 Q	K3.1 ■ 33 Q	K3.2 ■ 25 Q	K4.1 ■ 30 P	K4.2 ■ 23 P	K5.1 ■ 34 Q	K5.2 ■ 26 Q	N1.1 ■ 600 R	N1.2 ■ 450 R	N1.3 ■ 300 R
N2.1 ■ 769 R	N2.2 ■ 692 R	N2.3 ■ 500 R	N3.1 ■ 339 R	N3.2 ■ 200 R	N3.3 ■ 100 Q	N4.1 ■ 60 R							

Product	DC (mm)	CW (mm)	DCON MS (mm)	NOF	P (mm)	DHUB (mm)	DAH4 (mm)	DBC4 (mm)	DAH5 (mm)	DBC5 (mm)	DAH6 (mm)	DBC6 (mm)
D753250.0X2.0	250.00	2.0	32.00	100	8	100	8	45	9	50	11	63
D753350.0X2.5	350.00	2.5	32.00	140	8	120	8	45	9	50	11	63

D763

DORMER



Fraise 3 tailles en HSS-E à pas fin

Fraise conçue avec un pas fin, idéale pour réaliser des rainures étroites et profondes. La géométrie des dents alternées aide également à contrôler les copeaux pendant le fraisage. Un outil très polyvalent qui peut être utilisé pour le fraisage horizontal de rainures et les applications de tronçonnage. La finition brillante empêche la matière de la pièce de coller aux arêtes de coupe de l'outil.

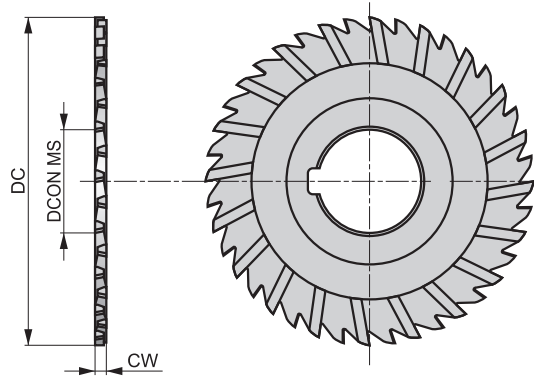

HSS-E		λ 15°
γ 10°	Bright	DC js16
DIN 885A		



Adéquation du groupe de matériaux de la pièce, valeurs de départ pour la vitesse de coupe (m/min) et code alpha. Tableaux d'avances par dent et facteurs de correction à partir de la page 261.

P1.1 ■ 46 X	P1.2 ■ 52 X	P1.3 ■ 54 X	P2.1 ■ 40 X	P2.2 ■ 35 X	P2.3 ■ 31 X	P3.1 ■ 29 X	P3.2 ■ 24 X	P3.3 ■ 20 X	P4.1 ■ 18 X	P4.2 ■ 15 X	P4.3 ■ 12 X	M1.1 ■ 41 X	M1.2 ■ 35 X
M2.1 ■ 37 X	M2.2 ■ 30 X	M3.1 ■ 23 X	M3.2 ■ 20 X	M3.3 ■ 18 X	M4.1 ■ 10 X	K1.1 ■ 30 X	K1.2 ■ 22 X	K1.3 ■ 17 X	K2.1 ■ 49 X	K2.2 ■ 40 X	K2.3 ■ 32 X	K3.1 ■ 44 X	K3.2 ■ 33 X
K3.3 ■ 27 X	K4.1 ■ 40 X	K4.2 ■ 30 X	K4.3 ■ 22 X	K4.4 ■ 19 X	K4.5 ■ 16 X	K5.1 ■ 46 X	K5.2 ■ 34 X	K5.3 ■ 27 X	N1.1 ■ 83 X	N1.2 ■ 62 X	N1.3 ■ 42 X	N2.1 ■ 42 X	N2.2 ■ 37 X
N2.3 ■ 27 X	N3.1 ■ 44 X	N3.2 ■ 25 X	N3.3 ■ 13 X	N4.1 ■ 44 S	S1.1 ■ 30 V	S1.2 ■ 20 W	S1.3 ■ 15 W	S2.1 ■ 20 W	S2.2 ■ 14 S	S3.1 ■ 15 W	S3.2 ■ 10 S	S4.1 ■ 12 W	S4.2 ■ 8 S

Product	DC	CW	DCON MS	NOF
	(mm)	(mm)	(mm)	
D76363.0X1.6	63.00	1.6	22.00	32
D76363.0X2.0	63.00	2.0	22.00	32
D76380.0X3.0	80.00	3.0	27.00	32
D763100.0X2.0	100.00	2.0	32.00	44
D763125.0X3.0	125.00	3.0	32.00	44

D400



Fraise 2 tailles de finition à trou lisse, en HSS-E avec finition brillante

Fraise avec une taille d'alésage standard se montant dans les mandrins porte-fraises standards et pouvant être utilisée pour le rainurage et la découpe. Disponible dans une large gamme de tailles avec des diamètres allant jusqu'à 50 mm. Finition brillante.

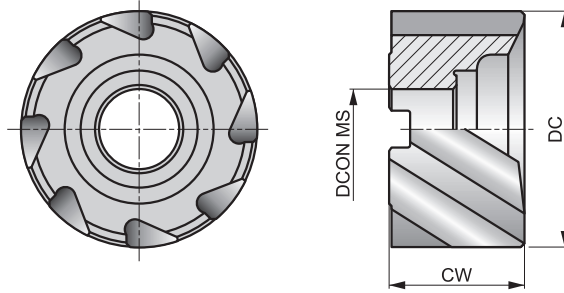

HSS-E	N	NOF 8
λ 30°	γ 12°	Bright
DC js16		DIN 1880



Adéquation du groupe de matériaux de la pièce, valeurs de départ pour la vitesse de coupe (m/min) et code alpha. Tableaux d'avances par dent et facteurs de correction à partir de la page 261.

P1.1 ■ 40 C	P1.2 ■ 45 C	P1.3 ■ 46 C	P2.1 ■ 34 C	P2.2 ■ 30 C	P2.3 ▧ 27 B	P3.1 ■ 29 C	P3.2 ■ 24 B	P3.3 ▧ 20 B	P4.1 ■ 18 B	P4.2 ▧ 15 B	P4.3 ▧ 12 B	M1.1 ■ 34 C	M1.2 ■ 29 C
M2.1 ■ 31 C	M2.2 ■ 25 B	M3.1 ▧ 17 B	M3.2 ▧ 15 B	M3.3 ■ 14 A	M4.1 ■ 10 A	K1.1 ■ 20 C	K1.2 ■ 15 C	K1.3 ■ 11 C	K2.1 ■ 37 C	K2.2 ■ 30 C	K2.3 ■ 24 B	K3.1 ■ 33 C	K3.2 ■ 25 C
K3.3 ■ 20 A	K4.1 ■ 30 B	K4.2 ■ 23 B	K4.3 ■ 17 B	K4.4 ■ 14 A	K4.5 ■ 12 A	K5.1 ■ 34 B	K5.2 ■ 26 B	K5.3 ■ 20 B	N1.1 ▧ 76 E	N1.2 ▧ 57 D	N1.3 ■ 38 D	N2.1 ■ 38 C	N2.2 ■ 34 C
N2.3 ■ 25 C	N3.1 ■ 40 C	N3.2 ■ 23 C	N3.3 ■ 12 C	N4.1 ▧ 40 C	N4.2 ▧ 15 C	N4.3 ▧ 17 C	S1.1 ■ 30 B	S1.2 ▧ 20 B	S1.3 ▧ 10 A	S2.1 ▧ 13 A	S2.2 ▧ 7 A	S3.1 ▧ 10 A	S3.2 ▧ 5 A
S4.1 ▧ 8 A	S4.2 ▧ 4 A												

Product	DC (mm)	CW (mm)	DCON MS (mm)	NOF
D40040.0	40.00	32.0	16.00	8
D40050.0	50.00	36.0	22.00	8

D420

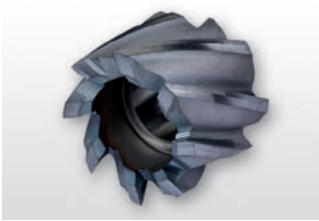

Fraise 2 tailles de finition à trou lisse, en HSS-E avec revêtement TiCN

Fraise avec une taille d'alésage standard se montant dans les mandrins porte-fraises standards et pouvant être utilisée pour le rainurage et la découpe. Disponible dans une large gamme de tailles avec des diamètres allant jusqu'à 63 mm. Le revêtement TiCN augmente la durée de vie de la fraise et améliore les performances lors du fraisage de matériaux durs et abrasifs.

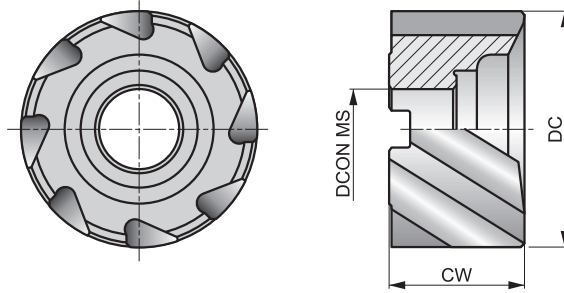

HSS-E	N	NOF 8
λ 30°	γ 12°	TiCN
DC js16		DIN 1880



Adéquation du groupe de matériaux de la pièce, valeurs de départ pour la vitesse de coupe (m/min) et code alpha. Tableaux d'avances par dent et facteurs de correction à partir de la page 261.

P1.1 ■ 86 C	P1.2 ■ 96 C	P1.3 ■ 100 C	P2.1 ■ 74 C	P2.2 ■ 65 C	P2.3 ■ 57 B	P3.1 ■ 52 C	P3.2 ■ 42 B	P3.3 ■ 35 B	P4.1 ■ 31 B	P4.2 ■ 26 B	P4.3 ■ 21 B	M1.1 ■ 48 C	M1.2 ■ 41 C
M2.1 ■ 43 C	M2.2 ■ 35 B	M3.1 ■ 35 B	M3.2 ■ 30 B	M3.3 ■ 27 A	M4.1 ■ 20 A	K1.1 ■ 35 C	K1.2 ■ 26 C	K1.3 ■ 19 C	K2.1 ■ 62 C	K2.2 ■ 50 C	K2.3 ■ 40 B	K3.1 ■ 54 C	K3.2 ■ 42 C
K3.3 ■ 34 A	K4.1 ■ 50 B	K4.2 ■ 38 B	K4.3 ■ 28 B	K4.4 ■ 24 A	K4.5 ■ 20 A	K5.1 ■ 57 B	K5.2 ■ 43 B	K5.3 ■ 33 B	N1.1 ▣ 159 E	N1.2 ▣ 120 D	N1.3 ■ 80 D	N2.1 ■ 80 C	N2.2 ■ 72 C
N2.3 ■ 51 C	N3.1 ■ 84 C	N3.2 ■ 50 C	N3.3 ■ 25 C	N4.1 ■ 84 C	N4.2 ▣ 32 C	N4.3 ▣ 35 C	S1.1 ■ 35 B	S1.2 ■ 25 B	S1.3 ■ 15 A	S2.1 ■ 27 A	S2.2 ■ 14 A	S3.1 ■ 20 A	S3.2 ■ 10 A
S4.1 ■ 16 A	S4.2 ■ 8 A												

Product	DC (mm)	CW (mm)	DCON MS (mm)	NOF
D42063.0	63.00	40.0	27.00	8

D402



Fraise 2 tailles d'ébauche à trou lisse, en HSS-E avec finition brillante

Fraise conçue avec un profil d'ébauche NR à pas gros pour un enlèvement de métal élevé. Disponible avec une taille d'alésage standard, la fraise peut être serrée dans un mandrin porte-fraises et convenir aux applications d'ébauche. Finition brillante.

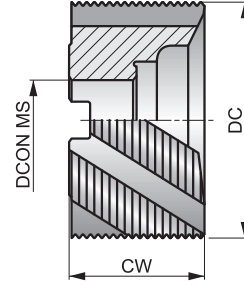
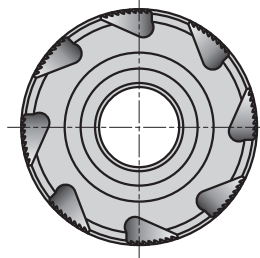

HSS-E	NR	NOF 8
λ 30°	γ 12°	Bright
DC js16		DIN 1880



Adéquation du groupe de matériaux de la pièce, valeurs de départ pour la vitesse de coupe (m/min) et code alpha. Tableaux d'avances par dent et facteurs de correction à partir de la page 261.

P1.1 ■ 40 D	P1.2 ■ 45 D	P1.3 ■ 46 D	P2.1 ■ 34 D	P2.2 ■ 30 D	P2.3 ▧ 27 C	P3.1 ■ 29 D	P3.2 ■ 24 C	P3.3 ▧ 20 C	P4.1 ■ 18 C	P4.2 ▧ 15 C	P4.3 ▧ 12 C	M1.1 ■ 34 D	M1.2 ■ 29 D
M2.1 ■ 31 D	M2.2 ■ 25 C	M3.1 ▧ 17 C	M3.2 ▧ 15 C	M3.3 ■ 14 B	M4.1 ■ 10 B	K1.1 ■ 20 D	K1.2 ■ 15 D	K1.3 ■ 11 D	K2.1 ■ 37 D	K2.2 ■ 30 D	K2.3 ■ 24 C	K3.1 ■ 33 D	K3.2 ■ 25 D
K3.3 ■ 20 B	K4.1 ■ 30 C	K4.2 ■ 23 C	K4.3 ■ 17 C	K4.4 ■ 14 B	K4.5 ■ 12 B	K5.1 ■ 34 C	K5.2 ■ 26 C	K5.3 ■ 20 C	N1.1 ▧ 76 F	N1.2 ▧ 57 E	N1.3 ■ 38 E	N2.1 ■ 38 D	N2.2 ■ 34 D
N2.3 ■ 25 D	N3.1 ■ 40 D	N3.2 ■ 23 D	N3.3 ■ 12 D	N4.1 ▧ 40 D	N4.2 ▧ 15 D	N4.3 ▧ 17 D	S1.1 ■ 30 C	S1.2 ▧ 20 C	S1.3 ▧ 10 B	S2.1 ▧ 13 B	S2.2 ▧ 7 B	S3.1 ▧ 10 B	S3.2 ▧ 5 B
S4.1 ▧ 8 B	S4.2 ▧ 4 B												

Product	DC (mm)	CW (mm)	DCON MS (mm)	NOF
D40263.0	63.00	40.0	27.00	8

Code de matériau du corps (BMC)	HM	HM	HM	HM	HM	HM	HM						
Profil de fraise	N	N	N	N	N	N	N						
Nombre de goujures (NOF)	NOF 2	NOF 2	NOF 3	NOF 3	NOF 4	NOF 4	NOF 4						
Longueur de coupe													
Angle d'hélice de goujure (FHA)	λ 30°	λ 30°	λ 30°	λ 30°	λ 30°	λ 30°	λ 30°						
Angle d'hélice de goujure (FHA)	λ 30°	λ 30°	λ 30°	λ 30°	λ 30°	λ 30°	λ 30°						
Angle de coupe radial (GAMF)	γ 12°	γ 12°	γ 12°	γ 12°	γ 12°	γ 12°	γ 12°						
Queue	 DIN 6535HA	 DIN 6535HB	 DIN 6535HA	 DIN 6535HB	 DIN 6535HA	 DIN 6535HB	 DIN 6535HB						
Revêtement	Bright	TiAlN	Bright	TiAlN	Bright	TiAlN	TiAlN						
Classe de tolérance du diamètre de coupe (TCDC)	DC h10	DC h10	DC h10	DC h10	DC h12	DC h12	DC h12						
Direction de coupe													
Groupe standard de base (BSG)													

		S902	S922	S903	S933	S904	S944	S991						
		2.00 – 20.00	2.00 – 20.00	2.00 – 20.00	2.00 – 20.00	2.00 – 20.00	2.00 – 20.00	2.00 – 20.00	Set					
		70	71	72	73	74	75	76						
P	P1	■	■	■	■	■	■							
	P2	■	■	■	■	■	■							
	P3	■	■	■	■	■	■							
	P4	▣	■	▣	■	▣	■							
M	M1													
	M2													
	M3													
	M4													
K	K1	▣	■	▣	■	▣	■							
	K2	■	■	■	■	■	■							
	K3	■	■	■	■	■	■							
	K4	▣	■	▣	■	▣	■							
	K5	■	■	■	■	■	■							
N	N1	▣	▣	▣	▣	▣	▣							
	N2	▣	■	▣	■	▣	■							
	N3	■	■	■	■	■	■							
	N4	▣	▣	▣	▣	▣	▣							
	N5													
S	S1	▣	▣	▣	▣	▣	▣							
	S2					▣	▣							
	S3					▣	▣							
	S4					▣	▣							
H	H1													
	H2													
	H3													
	H4													

S902



Fraise à rainurer en carbure monobloc à 2 dents

Fraise à 2 dents avec hélice à 30° et une longueur de coupe moyenne offrant une grande rigidité pour le fraisage de rainures standards.

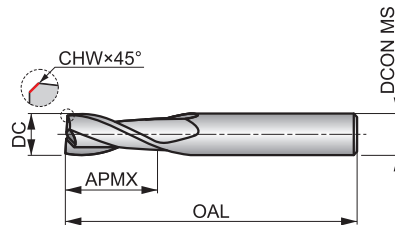

HM	N	NOF 2
	λ 30°	γ 12°
DIN 6535HA	Bright	DC h10
	DORMER	



Adéquation du groupe de matériaux de la pièce, valeurs de départ pour la vitesse de coupe (m/min) et code alpha. Tableaux d'avances par dent et facteurs de correction à partir de la page 266.

P1.1 ■ 106 K	P1.2 ■ 119 K	P1.3 ■ 123 K	P2.1 ■ 91 K	P2.2 ■ 80 K	P2.3 ▣ 71 J	P3.1 ■ 66 K	P3.2 ■ 53 J	P3.3 ▣ 45 J	P4.1 ■ 40 J	P4.2 ▣ 34 J	K1.1 ■ 80 K	K1.2 ▣ 59 K	K1.3 ▣ 44 K
K2.1 ■ 98 K	K2.2 ■ 80 K	K2.3 ▣ 64 J	K3.1 ■ 87 K	K3.2 ■ 67 K	K3.3 ▣ 54 J	K4.1 ■ 81 J	K4.2 ■ 61 J	K4.3 ▣ 45 J	K4.4 ▣ 38 J	K4.5 ▣ 32 J	K5.1 ■ 91 J	K5.2 ■ 69 J	K5.3 ▣ 53 J
N1.1 ▣ 355 K	N1.2 ■ 267 K	N1.3 ■ 179 K	N2.1 ■ 179 K	N2.2 ▣ 160 K	N2.3 ▣ 115 K	N3.1 ■ 187 K	N3.2 ■ 109 K	N3.3 ■ 56 K	N4.1 ▣ 187 K	N4.2 ▣ 172 K	S1.1 ■ 38 J	S1.2 ▣ 36 J	S1.3 ▣ 15 J

DCON MS tolérance h6; DC ≤ 10.00 mm: CHW ± 0.03 × 45° mm; DC > 10.00 mm: CHW ± 0.05 × 45° mm.

Product	DC (mm)	CHW (mm)	DCON MS (mm)	APMx (mm)	OAL (mm)	NOF
S9022.0	2.00	0.08	3.00	6.00	38.0	2
S9022.5	2.50	0.08	3.00	9.00	38.0	2
S9023.0	3.00	0.08	3.00	12.00	38.0	2
S9024.0	4.00	0.08	4.00	14.00	50.0	2
S9025.0	5.00	0.13	5.00	16.00	50.0	2
S9026.0	6.00	0.13	6.00	19.00	57.0	2
S9027.0	7.00	0.13	8.00	19.00	63.0	2
S9028.0	8.00	0.13	8.00	19.00	63.0	2
S9029.0	9.00	0.13	10.00	21.00	72.0	2
S90210.0	10.00	0.18	10.00	22.00	72.0	2
S90212.0	12.00	0.20	12.00	25.00	73.0	2
S90214.0	14.00	0.20	14.00	30.00	83.0	2
S90216.0	16.00	0.20	16.00	32.00	92.0	2
S90218.0	18.00	0.20	18.00	32.00	92.0	2
S90220.0	20.00	0.30	20.00	38.00	104.0	2

S922

DORMER



Fraise à rainurer en carbure monobloc à 2 dents

Fraise à 2 dents avec hélice à 30° offrant une grande rigidité pour le fraisage de rainures standards. Queue cylindrique pour les diamètres de coupe jusqu'à 5 mm et queue Weldon pour les diamètres supérieurs. Revêtement TiALN pour une meilleure résistance à la température et une durée de vie plus longue de l'outil.

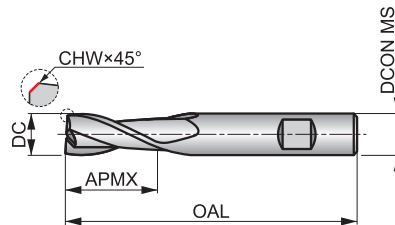

HM	N	NOF 2
	λ 30°	γ 12°
DIN 6535HB	TiALN	DC h10
	DORMER	



Adéquation du groupe de matériaux de la pièce, valeurs de départ pour la vitesse de coupe (m/min) et code alpha. Tableaux d'avances par dent et facteurs de correction à partir de la page 266.

P1.1 ■ 132 K	P1.2 ■ 148 K	P1.3 ■ 153 K	P2.1 ■ 113 K	P2.2 ■ 100 K	P2.3 ■ 88 J	P3.1 ■ 98 K	P3.2 ■ 79 J	P3.3 ■ 67 J	P4.1 ■ 59 J	P4.2 ■ 50 J	P4.3 ▣ 41 J	K1.1 ■ 100 K	K1.2 ■ 74 K
K1.3 ■ 56 K	K2.1 ■ 107 K	K2.2 ■ 87 K	K2.3 ■ 70 J	K3.1 ■ 95 K	K3.2 ■ 72 K	K3.3 ■ 59 J	K4.1 ■ 88 J	K4.2 ■ 67 J	K4.3 ■ 49 J	K4.4 ■ 42 J	K4.5 ■ 35 J	K5.1 ■ 100 J	K5.2 ■ 75 J
K5.3 ■ 58 J	N1.1 ▣ 296 K	N1.2 ▣ 222 K	N1.3 ■ 149 K	N2.1 ■ 149 K	N2.2 ■ 133 K	N2.3 ■ 96 K	N3.1 ■ 156 K	N3.2 ■ 91 K	N3.3 ▣ 47 K	N4.1 ▣ 156 K	N4.2 ▣ 60 K	N4.3 ▣ 64 K	S1.1 ■ 47 J
S1.2 ▣ 45 J	S1.3 ▣ 20 J												

DCON MS tolérance h6; DC ≤ 10.00 mm: CHW ± 0.03 × 45° mm; DC > 10.00 mm: CHW ± 0.05 × 45° mm.
Les produits de cette série sont également disponibles en coffret. Voir S991.

Product	DC (mm)	CHW (mm)	DCON MS (mm)	APM× (mm)	OAL (mm)	NOF
S9222.0 ¹⁾	2.00	0.08	3.00	6.00	38.0	2
S9222.5 ¹⁾	2.50	0.08	3.00	9.00	38.0	2
S9223.0 ¹⁾	3.00	0.08	3.00	12.00	38.0	2
S9224.0 ¹⁾	4.00	0.08	4.00	14.00	50.0	2
S9225.0 ¹⁾	5.00	0.13	5.00	16.00	50.0	2
S9226.0	6.00	0.13	6.00	19.00	57.0	2
S9227.0	7.00	0.13	8.00	19.00	63.0	2
S9228.0	8.00	0.13	8.00	19.00	63.0	2
S9229.0	9.00	0.13	10.00	21.00	72.0	2
S92210.0	10.00	0.18	10.00	22.00	72.0	2
S92212.0	12.00	0.20	12.00	25.00	73.0	2
S92214.0	14.00	0.20	14.00	30.00	83.0	2
S92216.0	16.00	0.20	16.00	32.00	92.0	2
S92218.0	18.00	0.20	18.00	32.00	92.0	2
S92220.0	20.00	0.30	20.00	38.00	104.0	2

¹⁾ Queue cylindrique.

S903



Fraise à rainurer en carbure monobloc à 3 dents

Fraise à 3 dents avec hélice à 30° et une longueur de coupe moyenne offrant une grande rigidité pour le fraisage de rainures standards.

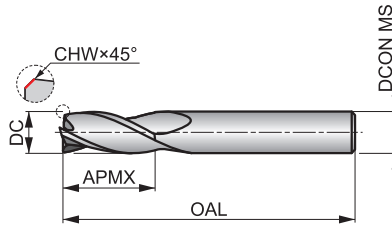

HM	N	NOF 3
	λ 30°	γ 12°
DIN 6535HA	Bright	DC h10



Adéquation du groupe de matériaux de la pièce, valeurs de départ pour la vitesse de coupe (m/min) et code alpha. Tableaux d'avances par dent et facteurs de correction à partir de la page 266.

P1.1 ■ 106 J	P1.2 ■ 119 J	P1.3 ■ 123 J	P2.1 ■ 91 J	P2.2 ■ 80 J	P2.3 ▣ 71 I	P3.1 ■ 66 J	P3.2 ■ 53 I	P3.3 ▣ 45 I	P4.1 ■ 40 I	P4.2 ▣ 34 I	K1.1 ■ 80 J	K1.2 ▣ 59 J	K1.3 ▣ 44 J
K2.1 ■ 98 J	K2.2 ■ 80 J	K2.3 ▣ 64 I	K3.1 ■ 87 J	K3.2 ■ 67 J	K3.3 ▣ 54 I	K4.1 ■ 81 I	K4.2 ■ 61 I	K4.3 ▣ 45 I	K4.4 ▣ 38 I	K4.5 ▣ 32 I	K5.1 ■ 91 I	K5.2 ■ 69 I	K5.3 ▣ 53 I
N1.1 ▣ 355 K	N1.2 ■ 267 K	N1.3 ■ 179 K	N2.1 ■ 179 J	N2.2 ▣ 160 J	N2.3 ▣ 115 J	N3.1 ■ 187 J	N3.2 ■ 109 J	N3.3 ■ 56 J	N4.1 ▣ 187 J	N4.2 ▣ 172 J	S1.1 ■ 38 I	S1.2 ▣ 36 I	S1.3 ▣ 43 I

DCON MS tolérance h6; DC ≤ 9.00 mm: CHW ± 0.03 × 45° mm; DC > 9.00 mm: CHW ± 0.05 × 45° mm.

Product	DC (mm)	CHW (mm)	DCON MS (mm)	APM× (mm)	OAL (mm)	NOF
S9032.0	2.00	0.08	3.00	6.00	38.0	3
S9032.5	2.50	0.08	3.00	9.00	38.0	3
S9033.0	3.00	0.08	3.00	12.00	38.0	3
S9034.0	4.00	0.08	4.00	14.00	50.0	3
S9035.0	5.00	0.13	5.00	16.00	50.0	3
S9036.0	6.00	0.13	6.00	19.00	57.0	3
S9037.0	7.00	0.13	8.00	19.00	63.0	3
S9038.0	8.00	0.13	8.00	19.00	63.0	3
S9039.0	9.00	0.13	10.00	21.00	72.0	3
S90310.0	10.00	0.20	10.00	22.00	72.0	3
S90312.0	12.00	0.20	12.00	25.00	73.0	3
S90314.0	14.00	0.20	14.00	30.00	83.0	3
S90316.0	16.00	0.20	16.00	32.00	92.0	3
S90318.0	18.00	0.20	18.00	32.00	92.0	3
S90320.0	20.00	0.30	20.00	38.00	104.0	3

S933

DORMER



Fraise à rainurer en carbure monobloc à 3 dents

Fraise à 3 dents avec hélice à 30° et une longueur de coupe moyenne offrant une grande rigidité pour le fraisage de rainures standards. Queue cylindrique pour un diamètre de coupe jusqu'à 5 mm. Revêtement TiAlN pour une meilleure résistance à la température et une plus grande durée de vie de l'outil.

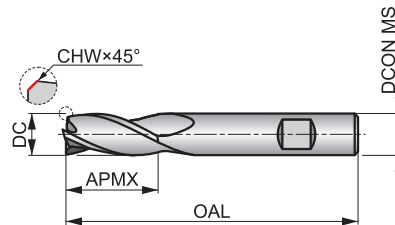

HM	N	NOF 3
	λ 30°	γ 12°
DIN 6358B	TiAlN	DC h10
	DORMER	



Adéquation du groupe de matériaux de la pièce, valeurs de départ pour la vitesse de coupe (m/min) et code alpha. Tableaux d'avances par dent et facteurs de correction à partir de la page 266.

P1.1 ■ 132 J	P1.2 ■ 148 J	P1.3 ■ 153 J	P2.1 ■ 113 J	P2.2 ■ 100 J	P2.3 ■ 88 l	P3.1 ■ 98 J	P3.2 ■ 79 l	P3.3 ■ 67 l	P4.1 ■ 59 l	P4.2 ■ 50 l	P4.3 □ 41 l	K1.1 ■ 100 J	K1.2 ■ 74 J
K1.3 ■ 56 J	K2.1 ■ 107 J	K2.2 ■ 87 J	K2.3 ■ 70 l	K3.1 ■ 95 J	K3.2 ■ 72 J	K3.3 ■ 59 l	K4.1 ■ 88 l	K4.2 ■ 67 l	K4.3 ■ 49 l	K4.4 ■ 42 l	K4.5 ■ 35 l	K5.1 ■ 100 l	K5.2 ■ 75 l
K5.3 ■ 58 l	N1.1 □ 296 K	N1.2 □ 222 K	N1.3 ■ 149 K	N2.1 ■ 149 J	N2.2 ■ 133 J	N2.3 ■ 96 J	N3.1 ■ 156 J	N3.2 ■ 91 J	N3.3 □ 47 J	N4.1 □ 156 J	N4.2 □ 60 J	N4.3 □ 64 J	S1.1 ■ 47 l
S1.2 □ 45 l	S1.3 □ 20 l												

DCON MS tolérance h6; DC ≤ 9.00 mm: CHW ± 0.03 × 45° mm; DC > 9.00 mm: CHW ± 0.05 × 45° mm.
Les produits de cette série sont également disponibles en coffret. Voir S991.

Product	DC (mm)	CHW (mm)	DCON MS (mm)	APM× (mm)	OAL (mm)	NOF
S9332.0 ¹⁾	2.00	0.08	3.00	6.00	38.0	3
S9332.5 ¹⁾	2.50	0.08	3.00	9.00	38.0	3
S9333.0 ¹⁾	3.00	0.08	3.00	12.00	38.0	3
S9334.0 ¹⁾	4.00	0.08	4.00	14.00	50.0	3
S9335.0 ¹⁾	5.00	0.13	5.00	16.00	50.0	3
S9336.0	6.00	0.13	6.00	19.00	57.0	3
S9337.0	7.00	0.13	8.00	19.00	63.0	3
S9338.0	8.00	0.13	8.00	19.00	63.0	3
S9339.0	9.00	0.13	10.00	21.00	72.0	3
S93310.0	10.00	0.20	10.00	22.00	72.0	3
S93312.0	12.00	0.20	12.00	25.00	73.0	3
S93314.0	14.00	0.20	14.00	30.00	83.0	3
S93316.0	16.00	0.20	16.00	32.00	92.0	3
S93318.0	18.00	0.20	18.00	32.00	92.0	3
S93320.0	20.00	0.30	20.00	38.00	104.0	3

¹⁾ Queue cylindrique.

S904



Fraise de finition en carbure monobloc à 4 dents

Fraise à 4 dents avec hélice à 30° et une longueur de coupe moyenne offrant une grande rigidité pour le fraisage de rainures standards.

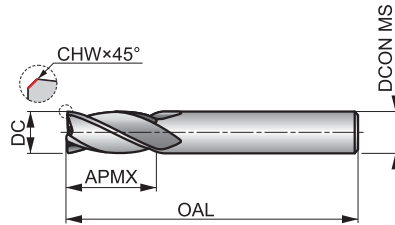

HM	N	NOF 4
	λ 30°	γ 12°
DIN 6535HA	Bright	DC h12
	DORMER	



Adéquation du groupe de matériaux de la pièce, valeurs de départ pour la vitesse de coupe (m/min) et code alpha. Tableaux d'avances par dent et facteurs de correction à partir de la page 266.

P1.1 ■ 106 J	P1.2 ■ 119 J	P1.3 ■ 123 J	P2.1 ■ 91 J	P2.2 ■ 80 J	P2.3 ▣ 71 l	P3.1 ■ 66 J	P3.2 ■ 53 l	P3.3 ▣ 45 l	P4.1 ■ 40 l	P4.2 ▣ 34 l	P4.3 ▣ 18 l	K1.1 ■ 80 J	K1.2 ▣ 59 J
K1.3 ▣ 44 J	K2.1 ■ 98 J	K2.2 ■ 80 J	K2.3 ▣ 64 l	K3.1 ■ 87 J	K3.2 ■ 67 J	K3.3 ▣ 54 l	K4.1 ■ 81 l	K4.2 ■ 61 l	K4.3 ▣ 45 l	K4.4 ▣ 38 l	K4.5 ▣ 32 l	K5.1 ■ 91 l	K5.2 ■ 69 l
K5.3 ▣ 53 l	N1.1 ▣ 355 J	N1.2 ■ 267 J	N1.3 ■ 179 J	N2.1 ■ 179 J	N2.2 ▣ 160 J	N2.3 ▣ 115 J	N3.1 ■ 187 J	N3.2 ■ 109 J	N3.3 ■ 56 J	N4.1 ▣ 187 J	N4.2 ▣ 72 J	S1.1 ■ 38 l	S1.2 ▣ 36 l
S1.3 ▣ 43 l	S2.1 ▣ 40 l	S2.2 ▣ 35 l	S3.1 ▣ 30 l	S3.2 ▣ 25 l	S4.1 ▣ 23 l	S4.2 ▣ 20 l							

DCON MS tolérance h6; DC ≤ 9.00 mm: CHW ± 0.03 × 45° mm; DC > 9.00 mm: CHW ± 0.05 × 45° mm.

Product	DC (mm)	CHW (mm)	DCON MS (mm)	APM× (mm)	OAL (mm)	NOF
S9042.0	2.00	0.08	3.00	6.00	38.0	4
S9042.5	2.50	0.08	3.00	9.00	38.0	4
S9043.0	3.00	0.08	3.00	12.00	38.0	4
S9044.0	4.00	0.08	4.00	14.00	50.0	4
S9045.0	5.00	0.13	5.00	16.00	50.0	4
S9046.0	6.00	0.13	6.00	19.00	57.0	4
S9047.0	7.00	0.13	8.00	19.00	63.0	4
S9048.0	8.00	0.13	8.00	19.00	63.0	4
S9049.0	9.00	0.13	10.00	21.00	72.0	4
S90410.0	10.00	0.20	10.00	22.00	72.0	4
S90412.0	12.00	0.20	12.00	25.00	73.0	4
S90414.0	14.00	0.20	14.00	30.00	83.0	4
S90416.0	16.00	0.20	16.00	32.00	92.0	4
S90418.0	18.00	0.20	18.00	32.00	92.0	4
S90420.0	20.00	0.30	20.00	38.00	104.0	4

S944



Fraise de finition en carbure monobloc à 4 dents

Fraise à 4 dents avec hélice à 30° et une longueur de coupe moyenne offrant une grande rigidité pour le fraisage de rainures standards. Queue cylindrique pour un diamètre de coupe jusqu'à 5 mm et queue Weldon pour les diamètres supérieurs. Revêtement TiAlN pour une meilleure résistance à la température et une plus grande durée de vie de l'outil.

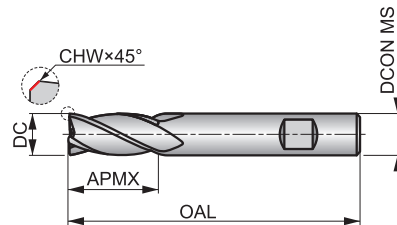

HM	N	NOF 4
	λ 30°	γ 12°
DIN 6335HB	TiAlN	DC h12
	DORMER	



Adéquation du groupe de matériaux de la pièce, valeurs de départ pour la vitesse de coupe (m/min) et code alpha. Tableaux d'avances par dent et facteurs de correction à partir de la page 266.

P1.1 ■ 132 J	P1.2 ■ 148 J	P1.3 ■ 153 J	P2.1 ■ 113 J	P2.2 ■ 100 J	P2.3 ■ 88 l	P3.1 ■ 98 J	P3.2 ■ 79 l	P3.3 ■ 67 l	P4.1 ■ 59 l	P4.2 ■ 50 l	P4.3 ▣ 41 l	K1.1 ■ 100 J	K1.2 ■ 74 J
K1.3 ■ 56 J	K2.1 ■ 107 J	K2.2 ■ 87 J	K2.3 ■ 70 l	K3.1 ■ 95 J	K3.2 ■ 72 J	K3.3 ■ 59 l	K4.1 ■ 88 l	K4.2 ■ 67 l	K4.3 ■ 49 l	K4.4 ■ 42 l	K4.5 ■ 35 l	K5.1 ■ 100 l	K5.2 ■ 75 l
K5.3 ■ 58 l	N1.1 ▣ 296 J	N1.2 ▣ 222 J	N1.3 ■ 149 J	N2.1 ■ 149 J	N2.2 ■ 133 J	N2.3 ■ 96 J	N3.1 ■ 156 J	N3.2 ■ 91 J	N3.3 ▣ 47 J	N4.1 ▣ 156 J	N4.2 ▣ 60 J	N4.3 ▣ 64 J	S1.1 ■ 47 l
S1.2 ▣ 45 l	S1.3 ▣ 45 l	S2.1 ▣ 60 l	S2.2 ▣ 49 l	S3.1 ▣ 45 l	S3.2 ▣ 35 l	S4.1 ▣ 35 l	S4.2 ▣ 28 l						

DCON MS tolérance h6; DC ≤ 9.00 mm: CHW ± 0.03 × 45° mm; DC > 9.00 mm: CHW ± 0.05 × 45° mm.
Les produits de cette série sont également disponibles en coffret. Voir S991.

Product	DC (mm)	CHW (mm)	DCON MS (mm)	APM× (mm)	OAL (mm)	NOF
S9442.0 ¹⁾	2.00	0.08	3.00	6.00	38.0	4
S9442.5 ¹⁾	2.50	0.08	3.00	9.00	38.0	4
S9443.0 ¹⁾	3.00	0.08	3.00	12.00	38.0	4
S9444.0 ¹⁾	4.00	0.08	4.00	14.00	50.0	4
S9445.0 ¹⁾	5.00	0.13	5.00	16.00	50.0	4
S9446.0	6.00	0.13	6.00	19.00	57.0	4
S9447.0	7.00	0.13	8.00	19.00	63.0	4
S9448.0	8.00	0.13	8.00	19.00	63.0	4
S9449.0	9.00	0.13	10.00	21.00	72.0	4
S94410.0	10.00	0.20	10.00	22.00	72.0	4
S94412.0	12.00	0.20	12.00	25.00	73.0	4
S94414.0	14.00	0.20	14.00	30.00	83.0	4
S94416.0	16.00	0.20	16.00	32.00	92.0	4
S94418.0	18.00	0.20	18.00	32.00	92.0	4
S94420.0	20.00	0.30	20.00	38.00	104.0	4

¹⁾ Queue cylindrique.



S991



Coffret de fraises en carbure monobloc

Coffret de 6 fraises en carbure monobloc avec revêtement TiALN. Gamme de S922, S933 ou S944 (2, 3 ou 4 dents). Les coffrets contiennent les Ø3, 4, 5, 6, 8 et 10 mm conditionnés dans une boîte ronde en plastique pour une bonne vue d'ensemble.

HM		

A=Types dans le coffret, B=Quantité dans le coffret, C=Diamètres dans le coffret.

Product	A	B	C
S991SET922	S922	6	Ø 3.00 mm, 4.00 mm, 5.00 mm, 6.00 mm, 8.00 mm, 10.00 mm
S991SET933	S933	6	Ø 3.00 mm, 4.00 mm, 5.00 mm, 6.00 mm, 8.00 mm, 10.00 mm
S991SET944	S944	6	Ø 3.00 mm, 4.00 mm, 5.00 mm, 6.00 mm, 8.00 mm, 10.00 mm



**OUTILS EN CARBURE MONOBLOC POUR LA FABRICATION MIXTE.
CONVIENT AUX PARAMÈTRES DE COUPE MODÉRÉS.**

Code de matériau du corps (BMC)	HM	HM	HM	HM	HM	HM	HM	HM	HM	HM	HM	HM	HM	HM
Profil de fraise	N	N	N	N	N	N	N	N	N	N	N	N	N	N
Nombre de goujures (NOF)	NOF 2	NOF 2	NOF 2	NOF 2	NOF 2	NOF 2	NOF 3	NOF 3	NOF 3	NOF 3	NOF 3	NOF 3	NOF 3	NOF 3
Longueur de coupe														
Angle d'hélice de goujure (FHA)	λ 28°	λ 28°	λ 28°	λ 28°	λ 40°	λ 28°	λ 28°	λ 28°	λ 28°	λ 28°	λ 40°	λ 28°	λ 40°	λ 40°
Angle d'hélice de goujure (FHA)	λ 28°	λ 28°	λ 28°	λ 28°	λ 40°	λ 28°	λ 28°	λ 28°	λ 28°	λ 28°	λ 40°	λ 28°	λ 40°	λ 40°
Angle de coupe radial (GAMF)	γ 9°	γ 9°	γ 9°	γ 9°	γ 10°	γ 9°	γ 9°	γ 9°	γ 9°	γ 9°	γ 10°	γ 9°	γ 10°	γ 10°
Queue														
Revêtement														
Classe de tolérance du diamètre de coupe (TCDC)	DC h9	DC h9	DC h9	DC h9	DC h9	DC h9	DC h9	DC h9	DC h9	DC h9	DC h9	DC h9	DC h9	DC h9
Direction de coupe														
Groupe standard de base (BSG)	DIN 6527K	DIN 6527K	DIN 6527L	DIN 6527L	DORMER	DORMER	DIN 6527K	DIN 6527K	DIN 6527L	DIN 6527L	DORMER	DORMER	DORMER	DORMER
Code de famille de produits	S802HA	S802HB	S812HA	S812HB	S710	S822	S803HA	S803HB	S813HA	S813HB	S713	S823	S714	S715
Plage de diamètres de coupe PSF	1.00 – 20.00	2.00 – 20.00	2.00 – 20.00	2.00 – 20.00	1.00 – 20.00	2.00 – 20.00	1.00 – 20.00	2.00 – 20.00	2.00 – 20.00	2.00 – 20.00	1.50 – 20.00	2.00 – 20.00	3.00 – 20.00	3.00 – 20.00
P	P1	■	■	■	■	■	■	■	■	■	■	■	■	■
	P2	■	■	■	■	■	■	■	■	■	■	■	■	■
	P3	■	■	■	■	■	■	■	■	■	■	■	■	■
	P4	■	■	■	■	■	■	■	■	■	■	■	■	■
M	M1	■	■	■	■	■	■	■	■	■	■	■	■	■
	M2	■	■	■	■	■	■	■	■	■	■	■	■	■
	M3	■	■	■	■	■	■	■	■	■	■	■	■	■
	M4	■	■	■	■	■	■	■	■	■	■	■	■	■
K	K1	■	■	■	■	■	■	■	■	■	■	■	■	■
	K2	■	■	■	■	■	■	■	■	■	■	■	■	■
	K3	■	■	■	■	■	■	■	■	■	■	■	■	■
	K4	■	■	■	■	■	■	■	■	■	■	■	■	■
	K5	■	■	■	■	■	■	■	■	■	■	■	■	■
N	N1	■	■	■	■	■	■	■	■	■	■	■	■	■
	N2	■	■	■	■	■	■	■	■	■	■	■	■	■
	N3	■	■	■	■	■	■	■	■	■	■	■	■	■
	N4	■	■	■	■	■	■	■	■	■	■	■	■	■
	N5	■	■	■	■	■	■	■	■	■	■	■	■	■
S	S1	■	■	■	■	■	■	■	■	■	■	■	■	■
	S2	■	■	■	■	■	■	■	■	■	■	■	■	■
	S3	■	■	■	■	■	■	■	■	■	■	■	■	■
	S4	■	■	■	■	■	■	■	■	■	■	■	■	■
H	H1													
	H2													
	H3													
	H4													

S802HA

DORMER



Fraise à rainurer P9 en carbure monobloc à 2 dents, queue HA DIN 6535

Fraise à 2 dents avec une longueur de coupe extra courte offrant une grande rigidité pour le fraisage de rainures peu profondes avec une tolérance P9. Peut être utilisée pour des opérations de ramping. Le revêtement AlCrN améliore les performances et prolonge la durée de vie de l'outil.

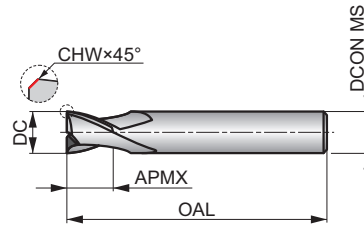

HM	N	NOF 2
	λ 28°	γ 9°
DIN 6535HA	AlCrN	
DIN 6527K		



Adéquation du groupe de matériaux de la pièce, valeurs de départ pour la vitesse de coupe (m/min) et code alpha. Tableaux d'avances par dent et facteurs de correction à partir de la page 266.

P1.1 ■ 206 K	P1.2 ■ 230 K	P1.3 ■ 238 K	P2.1 ■ 176 K	P2.2 ■ 155 K	P2.3 ■ 137 J	P3.1 ■ 143 K	P3.2 ■ 114 J	P3.3 ■ 97 J	P4.1 ■ 84 J	P4.2 ■ 72 J	P4.3 ■ 58 J	M1.1 ■ 121 K	M1.2 ■ 102 K
M2.1 ■ 107 K	M2.2 ■ 89 J	M2.3 ▣ 75 J	M3.1 ■ 99 J	M3.2 ■ 85 J	M3.3 ▣ 76 J	M4.1 ▣ 75 J	M4.2 ▣ 63 J	K1.1 ■ 205 K	K1.2 ■ 152 K	K1.3 ■ 114 K	K2.1 ■ 210 K	K2.2 ■ 171 K	K2.3 ■ 137 J
K3.1 ■ 186 K	K3.2 ■ 143 K	K3.3 ■ 115 J	K4.1 ■ 173 J	K4.2 ■ 131 J	K4.3 ■ 95 J	K4.4 ■ 82 J	K4.5 ■ 68 J	K5.1 ■ 196 J	K5.2 ■ 147 J	K5.3 ■ 114 J	N1.1 ▣ 408 K	N1.2 ▣ 307 K	N1.3 ■ 206 K
N2.1 ■ 206 K	N2.2 ■ 184 K	N2.3 ■ 132 K	N3.1 ■ 215 K	N3.2 ■ 125 K	N3.3 ▣ 64 K	N4.1 ▣ 215 K	N4.2 ▣ 83 K	S1.1 ▣ 81 J	S1.2 ▣ 71 J	S2.1 ▣ 55 J	S3.1 ▣ 41 J	S4.1 ▣ 32 J	

DCON MS tolérance h6; DC ≤ 7.75 mm: CHW ±0.03×45° mm; DC > 7.75 mm: CHW ±0.05×45° mm.

Product	DC (mm)	CHW (mm)	DCON MS (mm)	APMX (mm)	OAL (mm)	NOF
S802HA1.0	1.00	–	3.00	3.00	38.0	2
S802HA1.5	1.50	–	3.00	3.00	38.0	2
S802HA2.0	2.00	–	6.00	3.00	50.0	2
S802HA2.5	2.50	0.08	6.00	3.00	50.0	2
S802HA3.0	3.00	0.08	6.00	4.00	50.0	2
S802HA3.5	3.50	0.08	6.00	4.00	50.0	2
S802HA4.0	4.00	0.13	6.00	5.00	54.0	2
S802HA4.5	4.50	0.13	6.00	5.00	54.0	2
S802HA5.0	5.00	0.13	6.00	6.00	54.0	2
S802HA6.0	6.00	0.13	6.00	7.00	54.0	2
S802HA7.0	7.00	0.13	8.00	8.00	58.0	2
S802HA8.0	8.00	0.20	8.00	9.00	58.0	2
S802HA9.0	9.00	0.20	10.00	10.00	66.0	2
S802HA10.0	10.00	0.20	10.00	11.00	66.0	2
S802HA12.0	12.00	0.20	12.00	12.00	73.0	2
S802HA14.0	14.00	0.20	14.00	14.00	75.0	2
S802HA16.0	16.00	0.20	16.00	16.00	82.0	2
S802HA18.0	18.00	0.20	18.00	18.00	84.0	2
S802HA20.0	20.00	0.30	20.00	20.00	92.0	2

S802HB

DORMER



Fraise à rainurer P9 en carbure monobloc à 2 dents, queue HB DIN 6535

Fraise à 2 dents avec une longueur de coupe extra courte offrant une grande rigidité pour le fraisage de rainures peu profondes avec une tolérance P9. Peut être utilisée pour des opérations de ramping. La queue Weldon empêche la fraise de glisser dans le porte-outil. Le revêtement AlCrN améliore les performances et prolonge la durée de vie de l'outil.

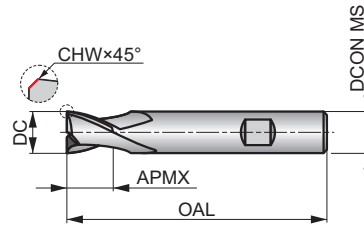

HM	N	NOF 2
	λ 28°	γ 9°
DIN 6535HB	AlCrN	
DIN 6527K		



Adéquation du groupe de matériaux de la pièce, valeurs de départ pour la vitesse de coupe (m/min) et code alpha. Tableaux d'avances par dent et facteurs de correction à partir de la page 266.

P1.1 ■ 206 K	P1.2 ■ 230 K	P1.3 ■ 238 K	P2.1 ■ 176 K	P2.2 ■ 155 K	P2.3 ■ 137 J	P3.1 ■ 143 K	P3.2 ■ 114 J	P3.3 ■ 97 J	P4.1 ■ 84 J	P4.2 ■ 72 J	P4.3 ■ 58 J	M1.1 ■ 121 K	M1.2 ■ 102 K
M2.1 ■ 107 K	M2.2 ■ 89 J	M2.3 ▣ 75 J	M3.1 ■ 99 J	M3.2 ■ 85 J	M3.3 ▣ 76 J	M4.1 ▣ 75 J	M4.2 ▣ 63 J	K1.1 ■ 205 K	K1.2 ■ 152 K	K1.3 ■ 114 K	K2.1 ■ 210 K	K2.2 ■ 171 K	K2.3 ■ 137 J
K3.1 ■ 186 K	K3.2 ■ 143 K	K3.3 ■ 115 J	K4.1 ■ 173 J	K4.2 ■ 131 J	K4.3 ■ 95 J	K4.4 ■ 82 J	K4.5 ■ 68 J	K5.1 ■ 196 J	K5.2 ■ 147 J	K5.3 ■ 114 J	N1.1 ▣ 408 K	N1.2 ▣ 307 K	N1.3 ■ 206 K
N2.1 ■ 206 K	N2.2 ■ 184 K	N2.3 ■ 132 K	N3.1 ■ 215 K	N3.2 ■ 125 K	N3.3 ▣ 64 K	N4.1 ▣ 215 K	N4.2 ▣ 83 K	S1.1 ▣ 81 J	S1.2 ▣ 71 J	S2.1 ▣ 55 J	S3.1 ▣ 41 J	S4.1 ▣ 32 J	

DCON MS tolérance h6; DC ≤ 7.75 mm: CHW ±0.03×45° mm; DC > 7.75 mm: CHW ±0.05×45° mm.

Product	DC (mm)	CHW (mm)	DCON MS (mm)	APMX (mm)	OAL (mm)	NOF
S802HB2.0	2.00	—	6.00	3.00	50.0	2
S802HB2.5	2.50	0.08	6.00	3.00	50.0	2
S802HB3.0	3.00	0.08	6.00	4.00	50.0	2
S802HB3.5	3.50	0.08	6.00	4.00	50.0	2
S802HB4.0	4.00	0.13	6.00	5.00	54.0	2
S802HB4.5	4.50	0.13	6.00	5.00	54.0	2
S802HB5.0	5.00	0.13	6.00	6.00	54.0	2
S802HB6.0	6.00	0.13	6.00	7.00	54.0	2
S802HB7.0	7.00	0.13	8.00	8.00	58.0	2
S802HB8.0	8.00	0.20	8.00	9.00	58.0	2
S802HB9.0	9.00	0.20	10.00	10.00	66.0	2
S802HB10.0	10.00	0.20	10.00	11.00	66.0	2
S802HB12.0	12.00	0.20	12.00	12.00	73.0	2
S802HB14.0	14.00	0.20	14.00	14.00	75.0	2
S802HB16.0	16.00	0.20	16.00	16.00	82.0	2
S802HB18.0	18.00	0.20	18.00	18.00	84.0	2
S802HB20.0	20.00	0.30	20.00	20.00	92.0	2

S812HA

DORMER



Fraise à rainurer P9 en carbure monobloc à 2 dents, queue HA DIN 6535

Fraise à 2 dents avec une longueur de coupe courte offrant une grande rigidité pour le fraisage de rainures standards avec une tolérance P9 et pour les opérations de ramping. Le revêtement AlCrN améliore les performances et prolonge la durée de vie de l'outil.

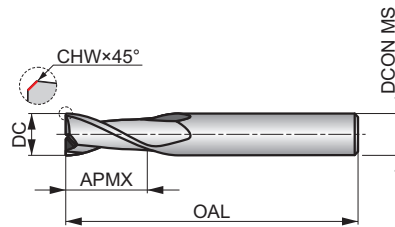

HM	N	NOF 2
	λ 28°	γ 9°
DIN 6535HA	AlCrN	
DIN 6527L		



Adéquation du groupe de matériaux de la pièce, valeurs de départ pour la vitesse de coupe (m/min) et code alpha. Tableaux d'avances par dent et facteurs de correction à partir de la page 266.

P1.1 ■ 166 K	P1.2 ■ 186 K	P1.3 ■ 192 K	P2.1 ■ 142 K	P2.2 ■ 125 K	P2.3 ■ 111 J	P3.1 ■ 115 K	P3.2 ■ 93 J	P3.3 ■ 78 J	P4.1 ■ 68 J	P4.2 ■ 59 J	P4.3 ■ 47 J	M1.1 ■ 97 K	M1.2 ■ 81 K
M2.1 ■ 85 K	M2.2 ■ 71 J	M3.1 ■ 79 J	M3.2 ■ 68 J	M3.3 ■ 61 J	M4.1 ■ 60 J	K1.1 ■ 166 K	K1.2 ■ 123 K	K1.3 ■ 92 K	K2.1 ■ 170 K	K2.2 ■ 138 K	K2.3 ■ 110 J	K3.1 ■ 150 K	K3.2 ■ 115 K
K3.3 ■ 93 J	K4.1 ■ 140 J	K4.2 ■ 105 J	K4.3 ■ 77 J	K4.4 ■ 66 J	K4.5 ■ 56 J	K5.1 ■ 159 J	K5.2 ■ 118 J	K5.3 ■ 92 J	N1.1 ■ 330 K	N1.2 ■ 247 K	N1.3 ■ 166 K	N2.1 ■ 166 K	N2.2 ■ 148 K
N2.3 ■ 107 K	N3.1 ■ 173 K	N3.2 ■ 101 K	N3.3 ■ 52 K	N4.1 ■ 173 K	N4.2 ■ 67 K	S1.1 ■ 72 J	S1.2 ■ 64 J	S2.1 ■ 49 J	S3.1 ■ 38 J	S4.1 ■ 30 J			

DCON MS tolérance h6; DC ≤ 7.00 mm: CHW ±0.03×45° mm; DC > 7.00 mm: CHW ±0.05×45° mm.

Product	DC (mm)	CHW (mm)	DCON MS (mm)	APMX (mm)	OAL (mm)	NOF
S812HA2.0	2.00	—	6.00	6.00	57.0	2
S812HA2.5	2.50	0.08	6.00	7.00	57.0	2
S812HA3.0	3.00	0.08	6.00	7.00	57.0	2
S812HA3.5	3.50	0.08	6.00	7.00	57.0	2
S812HA4.0	4.00	0.13	6.00	8.00	57.0	2
S812HA4.5	4.50	0.13	6.00	8.00	57.0	2
S812HA5.0	5.00	0.13	6.00	10.00	57.0	2
S812HA6.0	6.00	0.13	6.00	10.00	57.0	2
S812HA7.0	7.00	0.13	8.00	13.00	63.0	2
S812HA8.0	8.00	0.20	8.00	16.00	63.0	2
S812HA9.0	9.00	0.20	10.00	16.00	72.0	2
S812HA10.0	10.00	0.20	10.00	19.00	72.0	2
S812HA12.0	12.00	0.20	12.00	22.00	83.0	2
S812HA14.0	14.00	0.20	14.00	22.00	83.0	2
S812HA16.0	16.00	0.20	16.00	26.00	92.0	2
S812HA18.0	18.00	0.20	18.00	26.00	92.0	2
S812HA20.0	20.00	0.30	20.00	32.00	104.0	2

S812HB

DORMER



Fraise à rainurer P9 en carbure monobloc à 2 dents, queue HB DIN 6535

Fraise à 2 dents avec une longueur de coupe courte offrant une grande rigidité pour le fraisage de rainures standards avec une tolérance P9 et pour les opérations de ramping. La queue Weldon empêche la fraise de glisser dans le porte-outil. Le revêtement AlCrN améliore les performances et prolonge la durée de vie de l'outil.

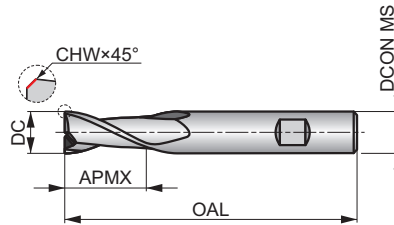

HM	N	NOF 2
	λ 28°	γ 9°
DIN 6535HB	AlCrN	
DIN 6527L		



Adéquation du groupe de matériaux de la pièce, valeurs de départ pour la vitesse de coupe (m/min) et code alpha. Tableaux d'avances par dent et facteurs de correction à partir de la page 266.

P1.1 ■ 166 K	P1.2 ■ 186 K	P1.3 ■ 192 K	P2.1 ■ 142 K	P2.2 ■ 125 K	P2.3 ■ 111 J	P3.1 ■ 115 K	P3.2 ■ 93 J	P3.3 ■ 78 J	P4.1 ■ 68 J	P4.2 ■ 59 J	P4.3 ■ 47 J	M1.1 ■ 97 K	M1.2 ■ 81 K
M2.1 ■ 85 K	M2.2 ■ 71 J	M3.1 ■ 79 J	M3.2 ■ 68 J	M3.3 ■ 61 J	M4.1 ■ 60 J	K1.1 ■ 166 K	K1.2 ■ 123 K	K1.3 ■ 92 K	K2.1 ■ 170 K	K2.2 ■ 138 K	K2.3 ■ 110 J	K3.1 ■ 150 K	K3.2 ■ 115 K
K3.3 ■ 93 J	K4.1 ■ 140 J	K4.2 ■ 105 J	K4.3 ■ 77 J	K4.4 ■ 66 J	K4.5 ■ 56 J	K5.1 ■ 159 J	K5.2 ■ 118 J	K5.3 ■ 92 J	N1.1 ■ 330 K	N1.2 ■ 247 K	N1.3 ■ 166 K	N2.1 ■ 166 K	N2.2 ■ 148 K
N2.3 ■ 107 K	N3.1 ■ 173 K	N3.2 ■ 101 K	N3.3 ■ 52 K	N4.1 ■ 173 K	N4.2 ■ 67 K	S1.1 ■ 72 J	S1.2 ■ 64 J	S2.1 ■ 49 J	S3.1 ■ 38 J	S4.1 ■ 30 J			

DCON MS tolérance h6; DC ≤ 7.00 mm: CHW ±0.03×45° mm; DC > 7.00 mm: CHW ±0.05×45° mm.

Product	DC (mm)	CHW (mm)	DCON MS (mm)	APMX (mm)	OAL (mm)	NOF
S812HB2.0	2.00	0.00	6.00	6.00	57.0	2
S812HB2.5	2.50	0.08	6.00	7.00	57.0	2
S812HB3.0	3.00	0.08	6.00	7.00	57.0	2
S812HB3.5	3.50	0.08	6.00	7.00	57.0	2
S812HB4.0	4.00	0.13	6.00	8.00	57.0	2
S812HB4.5	4.50	0.13	6.00	8.00	57.0	2
S812HB5.0	5.00	0.13	6.00	10.00	57.0	2
S812HB6.0	6.00	0.13	6.00	10.00	57.0	2
S812HB7.0	7.00	0.13	8.00	13.00	63.0	2
S812HB8.0	8.00	0.20	8.00	16.00	63.0	2
S812HB9.0	9.00	0.20	10.00	16.00	72.0	2
S812HB10.0	10.00	0.20	10.00	19.00	72.0	2
S812HB12.0	12.00	0.20	12.00	22.00	83.0	2
S812HB14.0	14.00	0.20	14.00	22.00	83.0	2
S812HB16.0	16.00	0.20	16.00	26.00	92.0	2
S812HB18.0	18.00	0.20	18.00	26.00	92.0	2
S812HB20.0	20.00	0.30	20.00	32.00	104.0	2

S710



Fraise à rainurer en carbure monobloc à 2 dents

Fraise à 2 dents avec hélice à 40° et une longueur de coupe courte offrant une grande rigidité pour le fraisage de rainures standards. Le revêtement AlCrN améliore les performances et prolonge la durée de vie de l'outil.

HM	N	NOF 2
	λ 40°	γ 10°
DIN 6535HA	AlCrN	DC h9

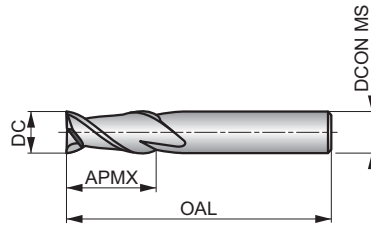

Adéquation du groupe de matériaux de la pièce, valeurs de départ pour la vitesse de coupe (m/min) et code alpha. Tableaux d'avances par dent et facteurs de correction à partir de la page 266.

P1.1 ■ 199 K	P1.2 ■ 223 K	P1.3 ■ 230 K	P2.1 ■ 170 K	P2.2 ■ 150 K	P2.3 ■ 133 J	P3.1 ■ 138 K	P3.2 ■ 111 J	P3.3 ■ 94 J	P4.1 ■ 82 J	P4.2 ■ 70 J	M1.1 ■ 115 K	M1.2 ■ 97 K	M2.1 ■ 102 K
M2.2 ■ 84 J	M3.1 ■ 94 J	M3.2 ■ 81 J	K1.1 ■ 196 K	K1.2 ■ 145 K	K1.3 ■ 109 K	K2.1 ■ 202 K	K2.2 ■ 164 K	K2.3 ■ 131 J	K3.1 ■ 178 K	K3.2 ■ 136 K	K3.3 ■ 110 J	K4.1 ■ 165 J	K4.2 ■ 125 J
K4.3 ■ 91 J	K4.4 ■ 78 J	K4.5 ■ 65 J	K5.1 ■ 187 J	K5.2 ■ 141 J	K5.3 ■ 109 J	S1.2 ■ 69 J	S2.1 ■ 53 J	S3.1 ■ 40 J	S4.1 ■ 31 J				

DCON MS tolérance h6.

Product	DC (mm)	DCON MS (mm)	APMX (mm)	OAL (mm)	NOF
S7101.0	1.00	3.00	3.00	40.0	2
S7101.5	1.50	3.00	4.50	40.0	2
S7102.0	2.00	3.00	6.50	40.0	2
S7102.5	2.50	3.00	6.50	40.0	2
S7103.0	3.00	6.00	9.00	50.0	2
S7104.0	4.00	6.00	12.00	50.0	2
S7105.0	5.00	6.00	15.00	50.0	2
S7106.0	6.00	6.00	20.00	60.0	2
S7108.0	8.00	8.00	20.00	64.0	2
S71010.0	10.00	10.00	22.00	75.0	2
S71012.0	12.00	12.00	25.00	75.0	2
S71016.0	16.00	16.00	32.00	90.0	2
S71020.0	20.00	20.00	38.00	100.0	2

S822



Fraise à rainurer P9 en carbure monobloc à 2 dents

Fraise à 2 dents avec une longueur de coupe moyenne offrant une grande rigidité pour le fraisage de rainures standards avec une tolérance P9 et pour les opérations de ramping. Le revêtement AlCrN améliore les performances et prolonge la durée de vie de l'outil.

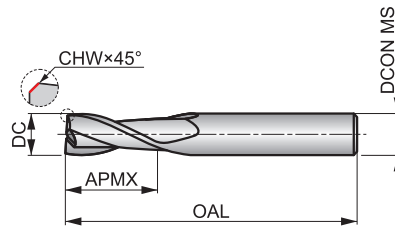

HM	N	NOF 2
	λ 28°	γ 9°
DIN 6535HA	AlCrN	
DORMER		



Adéquation du groupe de matériaux de la pièce, valeurs de départ pour la vitesse de coupe (m/min) et code alpha. Tableaux d'avances par dent et facteurs de correction à partir de la page 266.

P1.1 ■ 146 K	P1.2 ■ 164 K	P1.3 ■ 169 K	P2.1 ■ 125 K	P2.2 ■ 110 K	P2.3 ■ 98 J	P3.1 ■ 101 K	P3.2 ■ 82 J	P3.3 ■ 69 J	P4.1 ■ 61 J	P4.2 ■ 52 J	P4.3 ■ 41 J	M1.1 ■ 85 K	M1.2 ■ 72 K
M2.1 ■ 76 K	M2.2 ■ 62 J	M3.1 ■ 70 J	M3.2 ■ 60 J	M3.3 ■ 54 J	M4.1 ■ 53 J	K1.1 ■ 145 K	K1.2 ■ 108 K	K1.3 ■ 81 K	K2.1 ■ 150 K	K2.2 ■ 122 K	K2.3 ■ 97 J	K3.1 ■ 133 K	K3.2 ■ 102 K
K3.3 ■ 82 J	K4.1 ■ 123 J	K4.2 ■ 93 J	K4.3 ■ 68 J	K4.4 ■ 59 J	K4.5 ■ 48 J	K5.1 ■ 139 J	K5.2 ■ 105 J	K5.3 ■ 81 J	N1.1 ■ 287 K	N1.2 ■ 216 K	N1.3 ■ 144 K	N2.1 ■ 144 K	N2.2 ■ 129 K
N2.3 ■ 93 K	N3.1 ■ 152 K	N3.2 ■ 88 K	N3.3 ■ 45 K	N4.1 ■ 152 K	N4.2 ■ 59 K	S1.1 ■ 58 J	S1.2 ■ 51 J	S2.1 ■ 39 J	S3.1 ■ 29 J	S4.1 ■ 23 J			

DCON MS tolérance h6; DC ≤ 7.00 mm: CHW ±0.03×45° mm; DC > 7.00 mm: CHW ±0.05×45° mm.

Product	DC (mm)	CHW (mm)	DCON MS (mm)	APMX (mm)	OAL (mm)	NOF
S8222.0	2.00	—	6.00	8.00	57.0	2
S8222.5	2.50	0.08	6.00	12.00	57.0	2
S8223.0	3.00	0.08	6.00	12.00	57.0	2
S8224.0	4.00	0.13	6.00	14.00	57.0	2
S8225.0	5.00	0.13	6.00	16.00	57.0	2
S8226.0	6.00	0.13	6.00	19.00	57.0	2
S8227.0	7.00	0.13	8.00	19.00	63.0	2
S8228.0	8.00	0.20	8.00	19.00	63.0	2
S8229.0	9.00	0.20	10.00	21.00	72.0	2
S82210.0	10.00	0.20	10.00	22.00	72.0	2
S82212.0	12.00	0.20	12.00	25.00	83.0	2
S82214.0	14.00	0.20	14.00	30.00	83.0	2
S82216.0	16.00	0.20	16.00	32.00	92.0	2
S82218.0	18.00	0.20	18.00	32.00	92.0	2
S82220.0	20.00	0.30	20.00	38.00	104.0	2

S803HA



Fraise à rainurer P9 en carbure monobloc à 3 dents, queue HA DIN 6535

Fraise à 3 dents avec une longueur de coupe extra courte offrant une grande rigidité pour le fraisage de rainures peu profondes avec une tolérance P9. Le revêtement AlCrN augmente la durée de vie et améliore les performances. Convient également pour le tréflage et le fraisage en ramping.

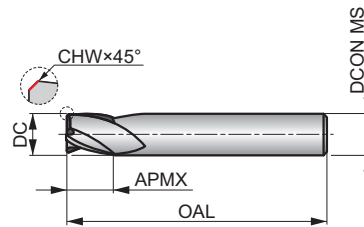

HM	N	NOF 3
	λ 28°	γ 9°
DIN 6535HA	AlCrN	
DIN 6527K		



Adéquation du groupe de matériaux de la pièce, valeurs de départ pour la vitesse de coupe (m/min) et code alpha. Tableaux d'avances par dent et facteurs de correction à partir de la page 266.

P1.1 ■ 206 J	P1.2 ■ 230 J	P1.3 ■ 238 J	P2.1 ■ 176 J	P2.2 ■ 155 J	P2.3 ■ 137 I	P3.1 ■ 143 J	P3.2 ■ 114 I	P3.3 ■ 97 I	P4.1 ■ 84 I	P4.2 ■ 72 I	P4.3 ■ 58 I	M1.1 ■ 121 J	M1.2 ■ 102 J
M2.1 ■ 107 J	M2.2 ■ 89 I	M2.3 ▣ 75 I	M3.1 ■ 99 I	M3.2 ■ 85 I	M3.3 ▣ 76 I	M4.1 ▣ 75 I	M4.2 ▣ 63 I	K1.1 ■ 205 J	K1.2 ■ 152 J	K1.3 ■ 114 J	K2.1 ■ 210 J	K2.2 ■ 171 J	K2.3 ■ 137 I
K3.1 ■ 186 J	K3.2 ■ 143 J	K3.3 ■ 115 I	K4.1 ■ 173 I	K4.2 ■ 131 I	K4.3 ■ 95 I	K4.4 ■ 82 I	K4.5 ■ 68 I	K5.1 ■ 196 I	K5.2 ■ 147 I	K5.3 ■ 114 I	N1.1 ▣ 408 K	N1.2 ▣ 307 K	N1.3 ■ 206 K
N2.1 ■ 206 J	N2.2 ■ 184 J	N2.3 ■ 132 J	N3.1 ■ 215 J	N3.2 ■ 125 J	N3.3 ▣ 64 J	N4.1 ▣ 215 J	N4.2 ▣ 183 J	S1.1 ▣ 81 I	S1.2 ▣ 71 I	S2.1 ▣ 55 I	S3.1 ▣ 41 I	S4.1 ▣ 32 I	

DCON MS tolérance h6; DC ≤ 7.75 mm: CHW ±0.03×45° mm; DC > 7.75 mm: CHW ±0.05×45° mm.

Product	DC (mm)	CHW (mm)	DCON MS (mm)	APMX (mm)	OAL (mm)	NOF
S803HA1.0	1.00	–	3.00	3.00	38.0	3
S803HA1.5	1.50	–	3.00	3.00	38.0	3
S803HA2.0	2.00	–	6.00	3.00	50.0	3
S803HA2.5	2.50	0.08	6.00	3.00	50.0	3
S803HA2.8	2.80	0.08	6.00	4.00	50.0	3
S803HA3.0	3.00	0.08	6.00	4.00	50.0	3
S803HA3.5	3.50	0.08	6.00	4.00	50.0	3
S803HA3.8	3.80	0.08	6.00	5.00	54.0	3
S803HA4.0	4.00	0.13	6.00	5.00	54.0	3
S803HA4.5	4.50	0.13	6.00	5.00	54.0	3
S803HA4.8	4.80	0.13	6.00	6.00	54.0	3
S803HA5.0	5.00	0.13	6.00	6.00	54.0	3
S803HA6.0	6.00	0.13	6.00	7.00	54.0	3
S803HA7.0	7.00	0.13	8.00	8.00	58.0	3
S803HA8.0	8.00	0.20	8.00	9.00	58.0	3
S803HA9.0	9.00	0.20	10.00	10.00	66.0	3
S803HA10.0	10.00	0.20	10.00	11.00	66.0	3
S803HA12.0	12.00	0.20	12.00	12.00	73.0	3
S803HA14.0	14.00	0.20	14.00	14.00	75.0	3
S803HA16.0	16.00	0.20	16.00	16.00	82.0	3
S803HA18.0	18.00	0.20	18.00	18.00	84.0	3
S803HA20.0	20.00	0.30	20.00	20.00	92.0	3

S803HB



Fraise à rainurer P9 en carbure monobloc à 3 dents, queue HB DIN 6535

Fraise à 3 dents avec une longueur de coupe extra courte offrant une grande rigidité pour le fraisage de rainures peu profondes avec une tolérance P9. La queue Weldon empêche la fraise de glisser dans le porte-outil. Le revêtement AlCrN augmente la durée de vie et améliore les performances. Convient également pour le treflage et le fraisage en ramping.

HM	N	NOF 3
	λ 28°	γ 9°
DIN 6535HB	AlCrN	
DIN 6527K		

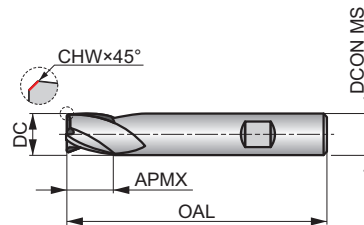

Adéquation du groupe de matériaux de la pièce, valeurs de départ pour la vitesse de coupe (m/min) et code alpha. Tableaux d'avances par dent et facteurs de correction à partir de la page 266.

P1.1 ■ 206 J	P1.2 ■ 230 J	P1.3 ■ 238 J	P2.1 ■ 176 J	P2.2 ■ 155 J	P2.3 ■ 137 I	P3.1 ■ 143 J	P3.2 ■ 114 I	P3.3 ■ 97 I	P4.1 ■ 84 I	P4.2 ■ 72 I	P4.3 ■ 58 I	M1.1 ■ 121 J	M1.2 ■ 102 J
M2.1 ■ 107 J	M2.2 ■ 89 I	M2.3 ■ 75 I	M3.1 ■ 99 I	M3.2 ■ 85 I	M3.3 ■ 76 I	M4.1 ■ 75 I	M4.2 ■ 63 I	K1.1 ■ 205 J	K1.2 ■ 152 J	K1.3 ■ 114 J	K2.1 ■ 210 J	K2.2 ■ 171 J	K2.3 ■ 137 I
K3.1 ■ 186 J	K3.2 ■ 143 J	K3.3 ■ 115 I	K4.1 ■ 173 I	K4.2 ■ 131 I	K4.3 ■ 95 I	K4.4 ■ 82 I	K4.5 ■ 68 I	K5.1 ■ 196 I	K5.2 ■ 147 I	K5.3 ■ 114 I	N1.1 ■ 408 K	N1.2 ■ 307 K	N1.3 ■ 206 K
N2.1 ■ 206 J	N2.2 ■ 184 J	N2.3 ■ 132 J	N3.1 ■ 215 J	N3.2 ■ 125 J	N3.3 ■ 64 J	N4.1 ■ 215 J	N4.2 ■ 183 J	S1.1 ■ 81 I	S1.2 ■ 71 I	S2.1 ■ 55 I	S3.1 ■ 41 I	S4.1 ■ 32 I	

DCON MS tolérance h6; DC ≤ 7.75 mm: CHW ±0.03×45° mm; DC > 7.75 mm: CHW ±0.05×45° mm.

Product	DC (mm)	CHW (mm)	DCON MS (mm)	APMX (mm)	OAL (mm)	NOF
S803HB2.0	2.00	—	6.00	3.00	50.0	3
S803HB2.5	2.50	0.08	6.00	3.00	50.0	3
S803HB2.8	2.80	0.08	6.00	4.00	50.0	3
S803HB3.0	3.00	0.08	6.00	4.00	50.0	3
S803HB3.5	3.50	0.08	6.00	4.00	50.0	3
S803HB3.8	3.80	0.08	6.00	5.00	54.0	3
S803HB4.0	4.00	0.13	6.00	5.00	54.0	3
S803HB4.5	4.50	0.13	6.00	5.00	54.0	3
S803HB4.8	4.80	0.13	6.00	6.00	54.0	3
S803HB5.0	5.00	0.13	6.00	6.00	54.0	3
S803HB5.75	5.75	0.13	6.00	7.00	54.0	3
S803HB6.0	6.00	0.13	6.00	7.00	54.0	3
S803HB6.75	6.75	0.13	8.00	8.00	58.0	3
S803HB7.0	7.00	0.13	8.00	8.00	58.0	3
S803HB7.75	7.75	0.13	8.00	9.00	58.0	3
S803HB8.0	8.00	0.20	8.00	9.00	58.0	3
S803HB9.0	9.00	0.20	10.00	10.00	66.0	3
S803HB9.7	9.70	0.20	10.00	11.00	66.0	3
S803HB10.0	10.00	0.20	10.00	11.00	66.0	3
S803HB11.7	11.70	0.20	12.00	12.00	73.0	3
S803HB12.0	12.00	0.20	12.00	12.00	73.0	3
S803HB14.0	14.00	0.20	14.00	14.00	75.0	3
S803HB16.0	16.00	0.20	16.00	16.00	82.0	3
S803HB18.0	18.00	0.20	18.00	18.00	84.0	3
S803HB20.0	20.00	0.30	20.00	20.00	92.0	3

S813HA

DORMER



Fraise à rainurer P9 en carbure monobloc à 3 dents, queue HA DIN 6535

Fraise à 3 dents avec une longueur de coupe courte offrant une grande rigidité pour le fraisage de rainures standards avec une tolérance P9. Le revêtement AlCrN augmente la durée de vie et améliore les performances. Convient également pour le tréflage et le fraisage en ramping.

HM	N	NOF 3
	λ 28°	γ 9°
DIN 6535HA	AlCrN	
DIN 6527L		

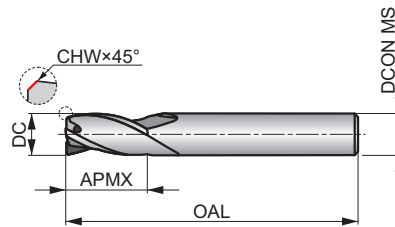

Adéquation du groupe de matériaux de la pièce, valeurs de départ pour la vitesse de coupe (m/min) et code alpha. Tableaux d'avances par dent et facteurs de correction à partir de la page 266.

P1.1 ■ 166 J	P1.2 ■ 186 J	P1.3 ■ 192 J	P2.1 ■ 142 J	P2.2 ■ 125 J	P2.3 ■ 111 I	P3.1 ■ 115 J	P3.2 ■ 93 I	P3.3 ■ 78 I	P4.1 ■ 68 I	P4.2 ■ 59 I	P4.3 ▣ 47 I	M1.1 ■ 97 J	M1.2 ■ 81 J
M2.1 ■ 85 J	M2.2 ■ 71 I	M3.1 ▣ 79 I	M3.2 ▣ 68 I	M3.3 ▣ 61 I	M4.1 ▣ 60 I	K1.1 ■ 166 J	K1.2 ■ 123 J	K1.3 ■ 92 J	K2.1 ■ 170 J	K2.2 ■ 138 J	K2.3 ■ 110 I	K3.1 ■ 150 J	K3.2 ■ 115 J
K3.3 ■ 93 I	K4.1 ■ 140 I	K4.2 ■ 105 I	K4.3 ■ 77 I	K4.4 ■ 66 I	K4.5 ■ 56 I	K5.1 ■ 159 I	K5.2 ■ 118 I	K5.3 ■ 92 I	N1.1 ▣ 330 K	N1.2 ▣ 247 K	N1.3 ■ 166 K	N2.1 ■ 166 J	N2.2 ■ 148 J
N2.3 ■ 107 J	N3.1 ■ 173 J	N3.2 ■ 101 J	N3.3 ▣ 52 J	N4.1 ▣ 173 J	N4.2 ▣ 67 J	S1.1 ▣ 72 I	S1.2 ▣ 64 I	S2.1 ▣ 49 I	S3.1 ▣ 38 I	S4.1 ▣ 30 I			

DCON MS tolérance h6; DC ≤ 7.00 mm: CHW ±0.03×45° mm; DC > 7.00 mm: CHW ±0.05×45° mm.

Product	DC (mm)	CHW (mm)	DCON MS (mm)	APMX (mm)	OAL (mm)	NOF
S813HA2.0	2.00	0.00	6.00	6.00	57.0	3
S813HA2.5	2.50	0.08	6.00	7.00	57.0	3
S813HA3.0	3.00	0.08	6.00	7.00	57.0	3
S813HA3.5	3.50	0.08	6.00	7.00	57.0	3
S813HA4.0	4.00	0.13	6.00	8.00	57.0	3
S813HA4.5	4.50	0.13	6.00	8.00	57.0	3
S813HA5.0	5.00	0.13	6.00	10.00	57.0	3
S813HA6.0	6.00	0.13	6.00	10.00	57.0	3
S813HA7.0	7.00	0.13	8.00	13.00	63.0	3
S813HA8.0	8.00	0.20	8.00	16.00	63.0	3
S813HA9.0	9.00	0.20	10.00	16.00	72.0	3
S813HA10.0	10.00	0.20	10.00	19.00	72.0	3
S813HA12.0	12.00	0.20	12.00	22.00	83.0	3
S813HA14.0	14.00	0.20	14.00	22.00	83.0	3
S813HA16.0	16.00	0.20	16.00	26.00	92.0	3
S813HA18.0	18.00	0.20	18.00	26.00	92.0	3
S813HA20.0	20.00	0.30	20.00	32.00	104.0	3

S813HB

DORMER



Fraise à rainurer P9 en carbure monobloc à 3 dents, queue HB DIN 6535

Fraise à 3 dents avec une longueur de coupe courte offrant une grande rigidité pour le fraisage de rainures standards avec une tolérance P9. La queue Weldon empêche la fraise de glisser dans le porte-outil. Le revêtement AlCrN améliore les performances et prolonge la durée de vie de l'outil. Convient également pour le tréflage et le fraisage en ramping.

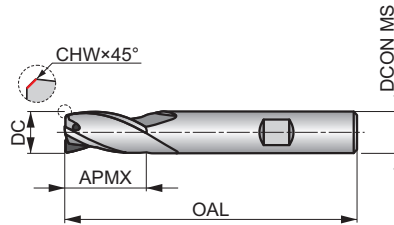

HM	N	NOF 3
	λ 28°	γ 9°
DIN 6535HB	AlCrN	
DIN 6527L		



Adéquation du groupe de matériaux de la pièce, valeurs de départ pour la vitesse de coupe (m/min) et code alpha. Tableaux d'avances par dent et facteurs de correction à partir de la page 266.

P1.1 ■ 166 J	P1.2 ■ 186 J	P1.3 ■ 192 J	P2.1 ■ 142 J	P2.2 ■ 125 J	P2.3 ■ 111 I	P3.1 ■ 115 J	P3.2 ■ 93 I	P3.3 ■ 78 I	P4.1 ■ 68 I	P4.2 ■ 59 I	P4.3 ■ 47 I	M1.1 ■ 97 J	M1.2 ■ 81 J
M2.1 ■ 85 J	M2.2 ■ 71 I	M3.1 ■ 79 I	M3.2 ■ 68 I	M3.3 ■ 61 I	M4.1 ■ 60 I	K1.1 ■ 166 J	K1.2 ■ 123 J	K1.3 ■ 92 J	K2.1 ■ 170 J	K2.2 ■ 138 J	K2.3 ■ 110 I	K3.1 ■ 150 J	K3.2 ■ 115 J
K3.3 ■ 93 I	K4.1 ■ 140 I	K4.2 ■ 105 I	K4.3 ■ 77 I	K4.4 ■ 66 I	K4.5 ■ 56 I	K5.1 ■ 159 I	K5.2 ■ 118 I	K5.3 ■ 92 I	N1.1 ■ 330 K	N1.2 ■ 247 K	N1.3 ■ 166 K	N2.1 ■ 166 J	N2.2 ■ 148 J
N2.3 ■ 107 J	N3.1 ■ 173 J	N3.2 ■ 101 J	N3.3 ■ 52 J	N4.1 ■ 173 J	N4.2 ■ 67 J	S1.1 ■ 72 I	S1.2 ■ 64 I	S2.1 ■ 49 I	S3.1 ■ 38 I	S4.1 ■ 30 I			

DCON MS tolérance h6; DC ≤ 7.00 mm: CHW ±0.03×45° mm; DC > 7.00 mm: CHW ±0.05×45° mm.

Product	DC (mm)	CHW (mm)	DCON MS (mm)	APMX (mm)	OAL (mm)	NOF
S813HB2.0	2.00	0.00	6.00	6.00	57.0	3
S813HB2.5	2.50	0.08	6.00	7.00	57.0	3
S813HB3.0	3.00	0.08	6.00	7.00	57.0	3
S813HB3.5	3.50	0.08	6.00	7.00	57.0	3
S813HB4.0	4.00	0.13	6.00	8.00	57.0	3
S813HB4.5	4.50	0.13	6.00	8.00	57.0	3
S813HB5.0	5.00	0.13	6.00	10.00	57.0	3
S813HB6.0	6.00	0.13	6.00	10.00	57.0	3
S813HB7.0	7.00	0.13	8.00	13.00	63.0	3
S813HB8.0	8.00	0.20	8.00	16.00	63.0	3
S813HB9.0	9.00	0.20	10.00	16.00	72.0	3
S813HB10.0	10.00	0.20	10.00	19.00	72.0	3
S813HB12.0	12.00	0.20	12.00	22.00	83.0	3
S813HB14.0	14.00	0.20	14.00	22.00	83.0	3
S813HB16.0	16.00	0.20	16.00	26.00	92.0	3
S813HB18.0	18.00	0.20	18.00	26.00	92.0	3
S813HB20.0	20.00	0.30	20.00	32.00	104.0	3

S713

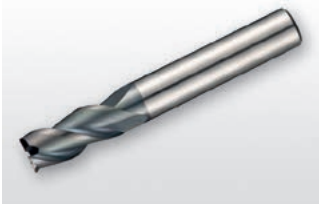

Fraise à rainurer en carbure monobloc à 3 dents

Fraise à 3 dents avec hélice à 40° et une longueur de coupe courte offrant une grande rigidité pour le fraisage de rainures standards. Le revêtement AlCrN améliore les performances et prolonge la durée de vie de l'outil.

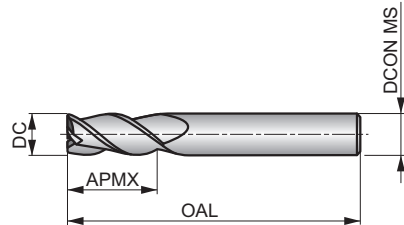

HM	N	NOF 3
	λ 40°	γ 10°
DIN 6535HA	AlCrN	DC h9

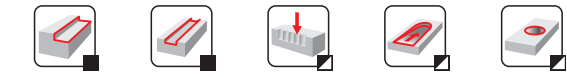

Adéquation du groupe de matériaux de la pièce, valeurs de départ pour la vitesse de coupe (m/min) et code alpha. Tableaux d'avances par dent et facteurs de correction à partir de la page 266.

P1.1 ■ 199 J	P1.2 ■ 223 J	P1.3 ■ 230 J	P2.1 ■ 170 J	P2.2 ■ 150 J	P2.3 ■ 133 I	P3.1 ■ 138 J	P3.2 ■ 111 I	P3.3 ■ 94 I	P4.1 ■ 82 I	P4.2 ■ 70 I	M1.1 ■ 115 J	M1.2 ■ 97 J	M2.1 ■ 102 J
M2.2 ■ 84 I	M3.1 ■ 94 I	M3.2 ■ 81 I	K1.1 ■ 196 J	K1.2 ■ 145 J	K1.3 ■ 109 J	K2.1 ■ 202 J	K2.2 ■ 164 J	K2.3 ■ 131 I	K3.1 ■ 178 J	K3.2 ■ 136 J	K3.3 ■ 110 I	K4.1 ■ 165 I	K4.2 ■ 125 I
K4.3 ■ 91 I	K4.4 ■ 78 I	K4.5 ■ 65 I	K5.1 ■ 187 I	K5.2 ■ 141 I	K5.3 ■ 109 I	S1.2 ■ 69 I	S2.1 ■ 53 I	S3.1 ■ 40 I	S4.1 ■ 31 I				

DCON MS tolérance h6.

Product	DC (mm)	DCON MS (mm)	APMX (mm)	OAL (mm)	NOF
S7131.5	1.50	4.00	4.50	40.0	3
S7132.0	2.00	4.00	6.50	40.0	3
S7133.0	3.00	3.00	9.00	40.0	3
S7134.0	4.00	4.00	12.00	50.0	3
S7135.0	5.00	5.00	15.00	50.0	3
S7136.0	6.00	6.00	16.00	50.0	3
S7138.0	8.00	8.00	20.00	64.0	3
S71310.0	10.00	10.00	22.00	70.0	3
S71312.0	12.00	12.00	25.00	75.0	3
S71314.0	14.00	14.00	32.00	90.0	3
S71316.0	16.00	16.00	32.00	90.0	3
S71318.0	18.00	18.00	38.00	100.0	3
S71320.0	20.00	20.00	38.00	100.0	3

S823

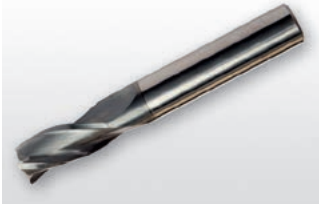

Fraise à rainurer P9 en carbure monobloc à 3 dents

Fraise à 3 dents avec une longueur de coupe moyenne offrant une grande rigidité pour le fraisage de rainures standards avec une tolérance P9 et pour les opérations de ramping. Le revêtement AlCrN améliore les performances et prolonge la durée de vie de l'outil.

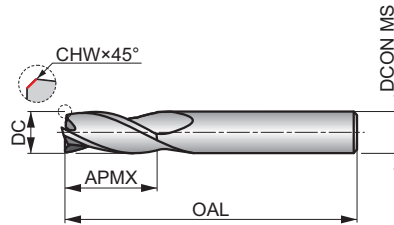

HM	N	NOF 3
	λ 28°	γ 9°
DIN 6535HA	AlCrN	
DORMER		



Adéquation du groupe de matériaux de la pièce, valeurs de départ pour la vitesse de coupe (m/min) et code alpha. Tableaux d'avances par dent et facteurs de correction à partir de la page 266.

P1.1 ■ 145 J	P1.2 ■ 162 J	P1.3 ■ 167 J	P2.1 ■ 124 J	P2.2 ■ 109 J	P2.3 ■ 97 I	P3.1 ■ 100 J	P3.2 ■ 81 I	P3.3 ■ 68 I	P4.1 ■ 60 I	P4.2 ■ 51 I	P4.3 ▣ 41 I	M1.1 ■ 84 J	M1.2 ■ 71 J
M2.1 ■ 75 J	M2.2 ■ 61 I	M3.1 ▣ 69 I	M3.2 ▣ 59 I	M3.3 ▣ 53 I	M4.1 ▣ 52 I	K1.1 ■ 144 J	K1.2 ■ 107 J	K1.3 ■ 80 J	K2.1 ■ 149 J	K2.2 ■ 121 J	K2.3 ■ 96 I	K3.1 ■ 132 J	K3.2 ■ 101 J
K3.3 ■ 81 I	K4.1 ■ 122 I	K4.2 ■ 92 I	K4.3 ■ 67 I	K4.4 ■ 58 I	K4.5 ■ 48 I	K5.1 ■ 138 I	K5.2 ■ 104 I	K5.3 ■ 80 I	N1.1 ▣ 284 K	N1.2 ▣ 214 K	N1.3 ■ 143 K	N2.1 ■ 143 J	N2.2 ■ 128 J
N2.3 ■ 92 J	N3.1 ■ 150 J	N3.2 ■ 87 J	N3.3 ▣ 45 J	N4.1 ▣ 150 J	N4.2 ▣ 58 J	S1.1 ▣ 113 I	S1.2 ▣ 100 I	S2.1 ▣ 77 I	S3.1 ▣ 58 I	S4.1 ▣ 45 I			

DCON MS tolérance h6; DC ≤ 7.00 mm: CHW ±0.03×45° mm; DC > 7.00 mm: CHW ±0.05×45° mm.

Product	DC (mm)	CHW (mm)	DCON MS (mm)	APMX (mm)	OAL (mm)	NOF
S8232.0	2.00	—	6.00	8.00	57.0	3
S8232.5	2.50	0.08	6.00	12.00	57.0	3
S8233.0	3.00	0.08	6.00	12.00	57.0	3
S8234.0	4.00	0.13	6.00	14.00	57.0	3
S8235.0	5.00	0.13	6.00	16.00	57.0	3
S8236.0	6.00	0.13	6.00	19.00	57.0	3
S8237.0	7.00	0.13	8.00	19.00	63.0	3
S8238.0	8.00	0.20	8.00	19.00	63.0	3
S8239.0	9.00	0.20	10.00	21.00	72.0	3
S82310.0	10.00	0.20	10.00	22.00	72.0	3
S82312.0	12.00	0.20	12.00	25.00	83.0	3
S82314.0	14.00	0.20	14.00	30.00	83.0	3
S82316.0	16.00	0.20	16.00	32.00	92.0	3
S82318.0	18.00	0.20	18.00	32.00	92.0	3
S82320.0	20.00	0.30	20.00	38.00	104.0	3

S714



Fraise à rainurer en carbure monobloc à 3 dents, série longue

Fraise à 3 dents avec hélice à 40° offrant une grande rigidité pour le fraisage de profil de parois profondes. Le revêtement AlCrN améliore les performances et prolonge la durée de vie de l'outil.

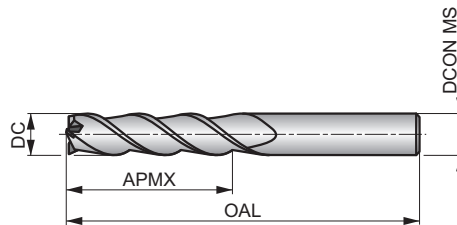

HM	N	NOF 3
	λ 40°	γ 10°
DIN 6535HA	AlCrN	DC h9



Adéquation du groupe de matériaux de la pièce, valeurs de départ pour la vitesse de coupe (m/min) et code alpha. Tableaux d'avances par dent et facteurs de correction à partir de la page 266.

P1.1 ■ 140 J	P1.2 ■ 157 J	P1.3 ■ 162 J	P2.1 ■ 120 J	P2.2 ■ 106 J	P2.3 ■ 94 I	P3.1 ■ 97 J	P3.2 ■ 78 I	P3.3 ■ 66 I	P4.1 ■ 58 I	P4.2 ■ 49 I	M1.1 ■ 81 J	M1.2 ■ 68 J	M2.1 ■ 71 J
M2.2 ■ 59 I	M3.1 ■ 66 I	M3.2 ■ 57 I	K1.1 ■ 138 J	K1.2 ■ 102 J	K1.3 ■ 77 J	K2.1 ■ 142 J	K2.2 ■ 115 J	K2.3 ■ 92 I	K3.1 ■ 125 J	K3.2 ■ 96 J	K3.3 ■ 78 I	K4.1 ■ 116 I	K4.2 ■ 88 I
K4.3 ■ 64 I	K4.4 ■ 55 I	K4.5 ■ 46 I	K5.1 ■ 132 I	K5.2 ■ 99 I	K5.3 ■ 77 I	N1.1 ▣ 249 K	N1.2 ▣ 187 K	N1.3 ▣ 125 K	N2.1 ▣ 125 J	N2.2 ▣ 112 J	N2.3 ▣ 81 J	N3.1 ▣ 131 J	N3.2 ▣ 76 J
N3.3 ▣ 39 J	S1.2 ■ 49 I	S2.1 ■ 37 I	S3.1 ■ 28 I	S4.1 ■ 22 I									

DCON MS tolérance h6.

Product	DC (mm)	DCON MS (mm)	APMX (mm)	OAL (mm)	NOF
S7143.0	3.00	3.00	19.00	60.0	3
S7144.0	4.00	4.00	19.00	60.0	3
S7145.0	5.00	5.00	19.00	60.0	3
S7146.0	6.00	6.00	31.00	75.0	3
S7148.0	8.00	8.00	31.00	75.0	3
S71410.0	10.00	10.00	31.00	75.0	3
S71412.0	12.00	12.00	50.00	100.0	3
S71414.0	14.00	14.00	57.00	125.0	3
S71416.0	16.00	16.00	57.00	125.0	3
S71418.0	18.00	18.00	57.00	125.0	3
S71420.0	20.00	20.00	57.00	125.0	3

S715



Fraise à rainurer en carbure monobloc à 3 dents, série extra longue

Fraise à 3 dents avec hélice à 40° et une longueur de coupe extra longue offrant une grande rigidité pour le fraisage de profil de parois très profondes. Le revêtement AlCrN améliore les performances et prolonge la durée de vie de l'outil.

HM	N	NOF 3
	λ 40°	γ 10°
DIN 6335HA	AlCrN	DC h9

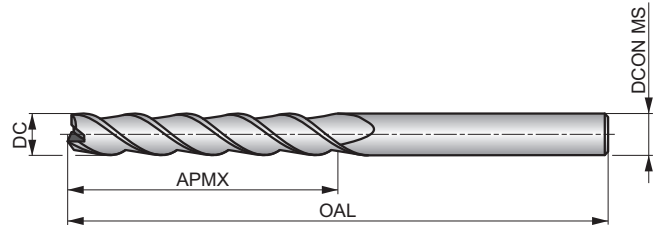

Adéquation du groupe de matériaux de la pièce, valeurs de départ pour la vitesse de coupe (m/min) et code alpha. Tableaux d'avances par dent et facteurs de correction à partir de la page 266.

P1.1 ■ 88 J	P1.2 ■ 98 J	P1.3 ■ 101 J	P2.1 ■ 75 J	P2.2 ■ 66 J	P2.3 ■ 59 I	P3.1 ■ 61 J	P3.2 ■ 49 I	P3.3 ■ 41 I	P4.1 ■ 36 I	P4.2 ■ 31 I	M1.1 ■ 50 J	M1.2 ■ 42 J	M2.1 ■ 44 J
M2.2 ■ 36 I	M3.1 ■ 41 I	M3.2 ■ 35 I	K1.1 ■ 86 J	K1.2 ■ 64 J	K1.3 ■ 48 J	K2.1 ■ 89 J	K2.2 ■ 72 J	K2.3 ■ 58 I	K3.1 ■ 79 J	K3.2 ■ 60 J	K3.3 ■ 49 I	K4.1 ■ 73 I	K4.2 ■ 55 I
K4.3 ■ 40 I	K4.4 ■ 35 I	K4.5 ■ 29 I	K5.1 ■ 83 I	K5.2 ■ 62 I	K5.3 ■ 48 I	N1.1 ▣ 178 K	N1.2 ▣ 134 K	N1.3 ▣ 190 K	N2.1 ▣ 190 J	N2.2 ▣ 180 J	N2.3 ▣ 158 J	N3.1 ▣ 194 J	N3.2 ▣ 155 J
N3.3 ▣ 28 J	S1.2 ■ 30 I	S2.1 ■ 23 I	S3.1 ■ 18 I	S4.1 ■ 14 I									

DCON MS tolérance h6.

Product	DC (mm)	DCON MS (mm)	APMX (mm)	OAL (mm)	NOF
S7153.0	3.00	3.00	25.00	100.0	3
S7154.0	4.00	4.00	31.00	100.0	3
S7155.0	5.00	5.00	31.00	100.0	3
S7156.0	6.00	6.00	38.00	100.0	3
S7158.0	8.00	8.00	41.00	100.0	3
S71510.0	10.00	10.00	57.00	125.0	3
S71512.0	12.00	12.00	75.00	150.0	3
S71514.0	14.00	14.00	75.00	150.0	3
S71516.0	16.00	16.00	75.00	150.0	3
S71518.0	18.00	18.00	75.00	150.0	3
S71520.0	20.00	20.00	75.00	150.0	3

Code de matériau du corps (BMC)	HM	HM	HM	HM	HM	HM	HM							
Profil de fraise	N	N	N	N	N	N	N							
Nombre de goujures (NOF)	NOF 4	NOF 4	NOF 4	NOF 4	NOF 4	NOF 4	NOF 4							
Longueur de coupe														
Angle d'hélice de goujure (FHA)	λ 34°	λ 34°	λ 34°	λ 34°	λ 40°	λ 40°	λ 40°							
Angle d'hélice de goujure (FHA)	λ 34°	λ 34°	λ 34°	λ 34°	λ 40°	λ 40°	λ 40°							
Angle de coupe radial (GAMF)	γ 9°	γ 9°	γ 9°	γ 9°	γ 10°	γ 10°	γ 10°							
Queue	DIN 6535HA	DIN 6535HB	DIN 6535HA	DIN 6535HB	DIN 6535HA	DIN 6535HA	DIN 6535HA							
Revêtement	AICN	AICN	AICN	AICN	AICN	AICN	AICN							
Classe de tolérance du diamètre de coupe (TCDC)	DC h10	DC h10	DC h10	DC h10	DC h9	DC h9	DC h9							
Direction de coupe														
Groupe standard de base (BSG)	DIN 6527K	DIN 6527K	DIN 6527L	DIN 6527L	DORMER	DORMER	DORMER							

Code de famille de produits		S804HA	S804HB	S814HA	S814HB	S716	S717	S718						
Plage de diamètres de coupe PSF		2.00 – 25.00	2.00 – 25.00	2.00 – 25.00	2.00 – 25.00	2.00 – 20.00	3.00 – 20.00	3.00 – 20.00						
P	P1	■	■	■	■	■	■	■						
	P2	■	■	■	■	■	■	■						
	P3	■	■	■	■	■	■	■						
	P4	■	■	■	■	■	■	■						
M	M1	■	■	■	■	■	■	■						
	M2	■	■	■	■	■	■	■						
	M3	■	■	▣	▣	■	■	■						
	M4	▣	▣	▣	▣	■	■	■						
K	K1	■	■	■	■	■	■	■						
	K2	■	■	■	■	■	■	■						
	K3	■	■	■	■	■	■	■						
	K4	■	■	■	■	■	■	■						
	K5	■	■	■	■	■	■	■						
N	N1	▣	▣	▣	▣		▣	▣						
	N2	▣	▣	▣	▣		▣	▣						
	N3	■	■	■	■		▣	▣						
	N4	▣	▣	▣	▣									
	N5													
S	S1	▣	▣	▣	▣	■	■	■						
	S2	▣	▣	▣	▣	■	■	■						
	S3	▣	▣	▣	▣	■	■	■						
	S4	▣	▣	▣	▣	■	■	■						
H	H1													
	H2													
	H3													
	H4													

S804HA

DORMER



Fraise de finition en carbure monobloc à 4 dents, queue HA DIN 6535

Fraise à 4 dents avec une longueur de coupe extra courte offrant une grande rigidité pour les applications de fraisage de profils peu profonds et de tréflage. Le revêtement AlCrN augmente la durée de vie et améliore les performances.

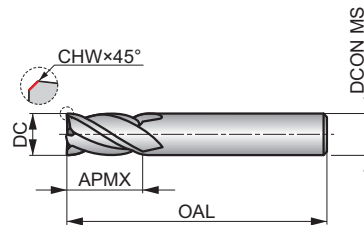

HM	N	NOF 4
	λ 34°	γ 9°
DIN 6535HA	AlCrN	DC h10
	DIN 6527K	



Adéquation du groupe de matériaux de la pièce, valeurs de départ pour la vitesse de coupe (m/min) et code alpha. Tableaux d'avances par dent et facteurs de correction à partir de la page 266.

P1.1 ■ 206 J	P1.2 ■ 230 J	P1.3 ■ 238 J	P2.1 ■ 176 J	P2.2 ■ 155 J	P2.3 ■ 137 I	P3.1 ■ 143 J	P3.2 ■ 114 I	P3.3 ■ 97 I	P4.1 ■ 84 I	P4.2 ■ 72 I	P4.3 ■ 58 I	M1.1 ■ 121 J	M1.2 ■ 102 J
M2.1 ■ 107 J	M2.2 ■ 89 I	M2.3 ▣ 175 I	M3.1 ■ 99 I	M3.2 ■ 85 I	M3.3 ▣ 176 I	M4.1 ▣ 175 I	M4.2 ▣ 163 I	K1.1 ■ 205 J	K1.2 ■ 152 J	K1.3 ■ 114 J	K2.1 ■ 210 J	K2.2 ■ 171 J	K2.3 ■ 137 I
K3.1 ■ 186 J	K3.2 ■ 143 J	K3.3 ■ 115 I	K4.1 ■ 173 I	K4.2 ■ 131 I	K4.3 ■ 95 I	K4.4 ■ 82 I	K4.5 ■ 68 I	K5.1 ■ 196 I	K5.2 ■ 147 I	K5.3 ■ 114 I	N1.1 ▣ 408 J	N1.2 ▣ 307 J	N1.3 ▣ 206 J
N2.1 ▣ 206 J	N2.2 ▣ 184 J	N2.3 ▣ 132 J	N3.1 ■ 215 J	N3.2 ■ 125 J	N3.3 ▣ 64 J	N4.1 ▣ 215 J	N4.2 ▣ 183 J	S1.1 ▣ 81 I	S1.2 ▣ 71 I	S2.1 ▣ 55 I	S3.1 ▣ 41 I	S4.1 ▣ 32 I	

DCON MS tolérance h6; DC ≤ 8.00 mm: CHW ±0.03×45° mm; DC > 8.00 mm: CHW ±0.05×45° mm.

Product	DC (mm)	CHW (mm)	DCON MS (mm)	APMX (mm)	OAL (mm)	NOF
S804HA2.0	2.00	—	6.00	4.00	50.0	4
S804HA3.0	3.00	0.08	6.00	5.00	50.0	4
S804HA4.0	4.00	0.13	6.00	8.00	54.0	4
S804HA5.0	5.00	0.13	6.00	9.00	54.0	4
S804HA6.0	6.00	0.13	6.00	10.00	54.0	4
S804HA8.0	8.00	0.13	8.00	12.00	58.0	4
S804HA10.0	10.00	0.20	10.00	14.00	66.0	4
S804HA12.0	12.00	0.20	12.00	16.00	73.0	4
S804HA16.0	16.00	0.20	16.00	22.00	82.0	4
S804HA20.0	20.00	0.30	20.00	26.00	92.0	4
S804HA25.0	25.00	0.30	25.00	32.00	121.0	4

S804HB

DORMER



Fraise de finition en carbure monobloc à 4 dents, queue HB DIN 6535

Fraise à 4 dents avec une longueur de coupe extra courte offrant une grande rigidité pour les applications de fraisage de profils peu profonds et de tréflage. La queue Weldon empêche la fraise de glisser dans le porte-outil. Le revêtement AlCrN augmente la durée de vie et améliore les performances.

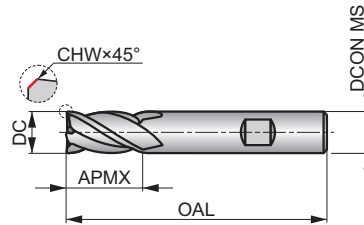

HM	N	NOF 4
	λ 34°	γ 9°
DIN 6535HB	AlCrN	DC h10
	DIN 6527K	



Adéquation du groupe de matériaux de la pièce, valeurs de départ pour la vitesse de coupe (m/min) et code alpha. Tableaux d'avances par dent et facteurs de correction à partir de la page 266.

P1.1 ■ 206 J	P1.2 ■ 230 J	P1.3 ■ 238 J	P2.1 ■ 176 J	P2.2 ■ 155 J	P2.3 ■ 137 I	P3.1 ■ 143 J	P3.2 ■ 114 I	P3.3 ■ 97 I	P4.1 ■ 84 I	P4.2 ■ 72 I	P4.3 ■ 58 I	M1.1 ■ 121 J	M1.2 ■ 102 J
M2.1 ■ 107 J	M2.2 ■ 89 I	M2.3 ■ 75 I	M3.1 ■ 99 I	M3.2 ■ 85 I	M3.3 ■ 76 I	M4.1 ■ 75 I	M4.2 ■ 63 I	K1.1 ■ 205 J	K1.2 ■ 152 J	K1.3 ■ 114 J	K2.1 ■ 210 J	K2.2 ■ 171 J	K2.3 ■ 137 I
K3.1 ■ 186 J	K3.2 ■ 143 J	K3.3 ■ 115 I	K4.1 ■ 173 I	K4.2 ■ 131 I	K4.3 ■ 95 I	K4.4 ■ 82 I	K4.5 ■ 68 I	K5.1 ■ 196 I	K5.2 ■ 147 I	K5.3 ■ 114 I	N1.1 ■ 408 J	N1.2 ■ 307 J	N1.3 ■ 206 J
N2.1 ■ 206 J	N2.2 ■ 184 J	N2.3 ■ 132 J	N3.1 ■ 215 J	N3.2 ■ 125 J	N3.3 ■ 64 J	N4.1 ■ 215 J	N4.2 ■ 183 J	S1.1 ■ 81 I	S1.2 ■ 71 I	S2.1 ■ 55 I	S3.1 ■ 41 I	S4.1 ■ 32 I	

DCON MS tolérance h6; DC ≤ 8.00 mm: CHW ±0.03×45° mm; DC > 8.00 mm: CHW ±0.05×45° mm.

Product	DC (mm)	CHW (mm)	DCON MS (mm)	APMX (mm)	OAL (mm)	NOF
S804HB2.0	2.00	—	6.00	4.00	50.0	4
S804HB3.0	3.00	0.08	6.00	5.00	50.0	4
S804HB4.0	4.00	0.13	6.00	8.00	54.0	4
S804HB5.0	5.00	0.13	6.00	9.00	54.0	4
S804HB6.0	6.00	0.13	6.00	10.00	54.0	4
S804HB8.0	8.00	0.13	8.00	12.00	58.0	4
S804HB10.0	10.00	0.20	10.00	14.00	66.0	4
S804HB12.0	12.00	0.20	12.00	16.00	73.0	4
S804HB16.0	16.00	0.20	16.00	22.00	82.0	4
S804HB20.0	20.00	0.30	20.00	26.00	92.0	4
S804HB25.0	25.00	0.30	25.00	32.00	121.0	4

S814HA



Fraise de finition en carbure monobloc à 4 dents, queue HA DIN 6535

Fraise à 4 dents avec une longueur de coupe courte offrant une grande rigidité pour les applications générales de profilage et de tréflage. Le revêtement AlCrN améliore les performances et prolonge la durée de vie de l'outil.

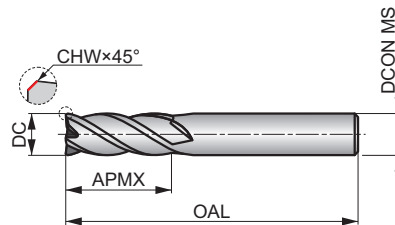

HM	N	NOF 4
	λ 34°	γ 9°
DIN 6535HA	AlCrN	
DIN 6527L	DC h10	



Adéquation du groupe de matériaux de la pièce, valeurs de départ pour la vitesse de coupe (m/min) et code alpha. Tableaux d'avances par dent et facteurs de correction à partir de la page 266.

P1.1 ■ 166 J	P1.2 ■ 186 J	P1.3 ■ 192 J	P2.1 ■ 142 J	P2.2 ■ 125 J	P2.3 ■ 111 I	P3.1 ■ 115 J	P3.2 ■ 93 I	P3.3 ■ 78 I	P4.1 ■ 68 I	P4.2 ■ 59 I	P4.3 ▣ 47 I	M1.1 ■ 97 J	M1.2 ■ 81 J
M2.1 ■ 85 J	M2.2 ■ 71 I	M3.1 ▣ 79 I	M3.2 ▣ 68 I	M3.3 ▣ 61 I	M4.1 ▣ 60 I	K1.1 ■ 166 J	K1.2 ■ 123 J	K1.3 ■ 92 J	K2.1 ■ 170 J	K2.2 ■ 138 J	K2.3 ■ 110 I	K3.1 ■ 150 J	K3.2 ■ 115 J
K3.3 ■ 93 I	K4.1 ■ 140 I	K4.2 ■ 105 I	K4.3 ■ 77 I	K4.4 ■ 66 I	K4.5 ■ 56 I	K5.1 ■ 159 I	K5.2 ■ 118 I	K5.3 ■ 92 I	N1.1 ▣ 330 J	N1.2 ▣ 247 J	N1.3 ▣ 166 J	N2.1 ▣ 166 J	N2.2 ▣ 148 J
N2.3 ▣ 107 J	N3.1 ■ 173 J	N3.2 ■ 101 J	N3.3 ▣ 52 J	N4.1 ▣ 173 J	N4.2 ▣ 67 J	S1.1 ▣ 72 I	S1.2 ▣ 64 I	S2.1 ▣ 49 I	S3.1 ▣ 38 I	S4.1 ▣ 30 I			

DCON MS tolérance h6; DC ≤ 8.00 mm: CHW ±0.03×45° mm; DC > 8.00 mm: CHW ±0.05×45° mm.

Product	DC (mm)	CHW (mm)	DCON MS (mm)	APMX (mm)	OAL (mm)	NOF
S814HA2.0	2.00	0.00	6.00	7.00	57.0	4
S814HA3.0	3.00	0.08	6.00	8.00	57.0	4
S814HA4.0	4.00	0.13	6.00	11.00	57.0	4
S814HA5.0	5.00	0.13	6.00	13.00	57.0	4
S814HA6.0	6.00	0.13	6.00	13.00	57.0	4
S814HA8.0	8.00	0.13	8.00	19.00	63.0	4
S814HA10.0	10.00	0.20	10.00	22.00	72.0	4
S814HA12.0	12.00	0.20	12.00	26.00	83.0	4
S814HA16.0	16.00	0.20	16.00	32.00	92.0	4
S814HA20.0	20.00	0.30	20.00	38.00	104.0	4
S814HA25.0	25.00	0.30	25.00	45.00	121.0	4

S814HB

DORMER



Fraise de finition en carbure monobloc à 4 dents, queue HB DIN 6535

Fraise à 4 dents avec une longueur de coupe courte offrant une grande rigidité pour les applications générales de profilage et de tréflage. La queue Weldon empêche la fraise de glisser dans le porte-outil. Le revêtement AlCrN améliore les performances et prolonge la durée de vie de l'outil.

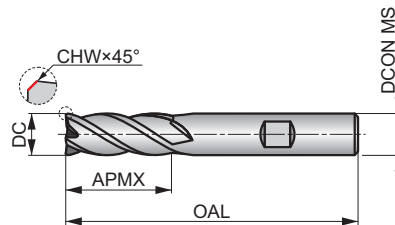

HM	N	NOF 4
	λ 34°	γ 9°
DIN 6535HB	AlCrN	DC h10
	DIN 6527L	



Adéquation du groupe de matériaux de la pièce, valeurs de départ pour la vitesse de coupe (m/min) et code alpha. Tableaux d'avances par dent et facteurs de correction à partir de la page 266.

P1.1 ■ 166 J	P1.2 ■ 186 J	P1.3 ■ 192 J	P2.1 ■ 142 J	P2.2 ■ 125 J	P2.3 ■ 111 I	P3.1 ■ 115 J	P3.2 ■ 93 I	P3.3 ■ 78 I	P4.1 ■ 68 I	P4.2 ■ 59 I	P4.3 ▣ 47 I	M1.1 ■ 97 J	M1.2 ■ 81 J
M2.1 ■ 85 J	M2.2 ■ 71 I	M3.1 ▣ 79 I	M3.2 ▣ 68 I	M3.3 ▣ 61 I	M4.1 ▣ 60 I	K1.1 ■ 166 J	K1.2 ■ 123 J	K1.3 ■ 92 J	K2.1 ■ 170 J	K2.2 ■ 138 J	K2.3 ■ 110 I	K3.1 ■ 150 J	K3.2 ■ 115 J
K3.3 ■ 93 I	K4.1 ■ 140 I	K4.2 ■ 105 I	K4.3 ■ 77 I	K4.4 ■ 66 I	K4.5 ■ 56 I	K5.1 ■ 159 I	K5.2 ■ 118 I	K5.3 ■ 92 I	N1.1 ▣ 330 J	N1.2 ▣ 247 J	N1.3 ▣ 166 J	N2.1 ▣ 166 J	N2.2 ▣ 148 J
N2.3 ▣ 107 J	N3.1 ■ 173 J	N3.2 ■ 101 J	N3.3 ▣ 52 J	N4.1 ▣ 173 J	N4.2 ▣ 67 J	S1.1 ▣ 72 I	S1.2 ▣ 64 I	S2.1 ▣ 49 I	S3.1 ▣ 38 I	S4.1 ▣ 30 I			

DCON MS tolérance h6; DC ≤ 8.00 mm: CHW ±0.03×45° mm; DC > 8.00 mm: CHW ±0.05×45° mm.

Product	DC (mm)	CHW (mm)	DCON MS (mm)	APMX (mm)	OAL (mm)	NOF
S814HB2.0	2.00	0.00	6.00	7.00	57.0	4
S814HB3.0	3.00	0.08	6.00	8.00	57.0	4
S814HB4.0	4.00	0.13	6.00	11.00	57.0	4
S814HB5.0	5.00	0.13	6.00	13.00	57.0	4
S814HB6.0	6.00	0.13	6.00	13.00	57.0	4
S814HB8.0	8.00	0.13	8.00	19.00	63.0	4
S814HB10.0	10.00	0.20	10.00	22.00	72.0	4
S814HB12.0	12.00	0.20	12.00	26.00	83.0	4
S814HB16.0	16.00	0.20	16.00	32.00	92.0	4
S814HB20.0	20.00	0.30	20.00	38.00	104.0	4
S814HB25.0	25.00	0.30	25.00	45.00	121.0	4

S716



Fraise de finition en carbure monobloc à 4 dents

Fraise à 4 dents avec hélice à 40° et une longueur de coupe courte offrant une grande rigidité pour le fraisage de profil standard. Le revêtement AlCrN améliore les performances et prolonge la durée de vie de l'outil.

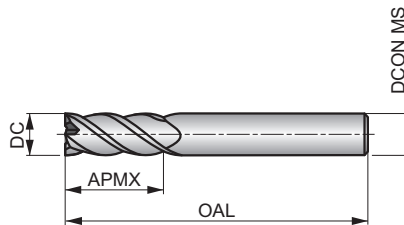

HM	N	NOF 4
	λ 40°	γ 10°
DIN 6535HA	AlCrN	DC h9



Adéquation du groupe de matériaux de la pièce, valeurs de départ pour la vitesse de coupe (m/min) et code alpha. Tableaux d'avances par dent et facteurs de correction à partir de la page 266.

P1.1 ■ 199 J	P1.2 ■ 223 J	P1.3 ■ 230 J	P2.1 ■ 170 J	P2.2 ■ 150 J	P2.3 ■ 133 I	P3.1 ■ 138 J	P3.2 ■ 111 I	P3.3 ■ 94 I	P4.1 ■ 82 I	P4.2 ■ 70 I	M1.1 ■ 115 J	M1.2 ■ 97 J	M2.1 ■ 102 J
M2.2 ■ 84 I	M3.1 ■ 94 I	M3.2 ■ 81 I	K1.1 ■ 196 J	K1.2 ■ 145 J	K1.3 ■ 109 J	K2.1 ■ 202 J	K2.2 ■ 164 J	K2.3 ■ 131 I	K3.1 ■ 178 J	K3.2 ■ 136 J	K3.3 ■ 110 I	K4.1 ■ 165 I	K4.2 ■ 125 I
K4.3 ■ 91 I	K4.4 ■ 78 I	K4.5 ■ 65 I	K5.1 ■ 187 I	K5.2 ■ 141 I	K5.3 ■ 109 I	S1.2 ■ 69 I	S2.1 ■ 53 I	S3.1 ■ 40 I	S4.1 ■ 31 I				

DCON MS tolérance h6.

Product	DC (mm)	DCON MS (mm)	APMX (mm)	OAL (mm)	NOF
S7162.0	2.00	4.00	6.50	40.0	4
S7163.0	3.00	3.00	9.00	40.0	4
S7164.0	4.00	4.00	12.00	50.0	4
S7165.0	5.00	5.00	15.00	50.0	4
S7166.0	6.00	6.00	16.00	50.0	4
S7168.0	8.00	8.00	20.00	64.0	4
S71610.0	10.00	10.00	22.00	70.0	4
S71612.0	12.00	12.00	25.00	75.0	4
S71614.0	14.00	14.00	32.00	90.0	4
S71616.0	16.00	16.00	32.00	90.0	4
S71618.0	18.00	18.00	38.00	100.0	4
S71620.0	20.00	20.00	38.00	100.0	4

S717



Fraise de finition en carbure monobloc à 4 dents, série longue

Fraise à 4 dents avec hélice à 40° et une grande longueur de coupe offrant une grande rigidité pour le fraisage de parois profondes et assurant un usinage haute performance. Le revêtement AlCrN améliore les performances et prolonge la durée de vie de l'outil.

HM	N	NOF 4
	λ 40°	γ 10°
DIN 6535HA	AlCrN	DC h9
	DORMER	

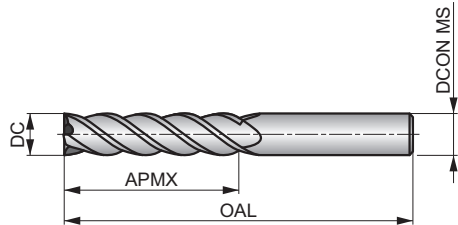

Adéquation du groupe de matériaux de la pièce, valeurs de départ pour la vitesse de coupe (m/min) et code alpha. Tableaux d'avances par dent et facteurs de correction à partir de la page 266.

P1.1 ■ 140 J	P1.2 ■ 157 J	P1.3 ■ 162 J	P2.1 ■ 120 J	P2.2 ■ 106 J	P2.3 ■ 94 I	P3.1 ■ 97 J	P3.2 ■ 78 I	P3.3 ■ 66 I	P4.1 ■ 58 I	P4.2 ■ 49 I	M1.1 ■ 81 J	M1.2 ■ 68 J	M2.1 ■ 71 J
M2.2 ■ 59 I	M3.1 ■ 66 I	M3.2 ■ 57 I	K1.1 ■ 138 J	K1.2 ■ 102 J	K1.3 ■ 77 J	K2.1 ■ 142 J	K2.2 ■ 115 J	K2.3 ■ 92 I	K3.1 ■ 125 J	K3.2 ■ 96 J	K3.3 ■ 78 I	K4.1 ■ 116 I	K4.2 ■ 88 I
K4.3 ■ 64 I	K4.4 ■ 55 I	K4.5 ■ 46 I	K5.1 ■ 132 I	K5.2 ■ 99 I	K5.3 ■ 77 I	N1.1 ▣ 249 K	N1.2 ▣ 187 K	N1.3 ▣ 125 K	N2.1 ▣ 125 J	N2.2 ▣ 112 J	N2.3 ▣ 81 J	N3.1 ▣ 131 J	N3.2 ▣ 176 J
N3.3 ▣ 39 J	S1.2 ■ 49 I	S2.1 ■ 37 I	S3.1 ■ 28 I	S4.1 ■ 22 I									

DCON MS tolérance h6.

Product	DC (mm)	DCON MS (mm)	APMX (mm)	OAL (mm)	NOF
S7173.0	3.00	3.00	19.00	60.0	4
S7174.0	4.00	4.00	19.00	60.0	4
S7175.0	5.00	5.00	19.00	60.0	4
S7176.0	6.00	6.00	31.00	75.0	4
S7178.0	8.00	8.00	31.00	75.0	4
S71710.0	10.00	10.00	31.00	75.0	4
S71712.0	12.00	12.00	50.00	100.0	4
S71714.0	14.00	14.00	57.00	125.0	4
S71716.0	16.00	16.00	57.00	125.0	4
S71718.0	18.00	18.00	57.00	125.0	4
S71720.0	20.00	20.00	57.00	125.0	4

S718

DORMER



Fraise de finition en carbure monobloc à 4 dents, série extra longue

Fraise à 4 dents avec hélice à 40° et une longueur de coupe extra longue offrant une grande rigidité pour le fraisage de profil de parois très profondes. Le revêtement AlCrN améliore les performances et prolonge la durée de vie de l'outil.

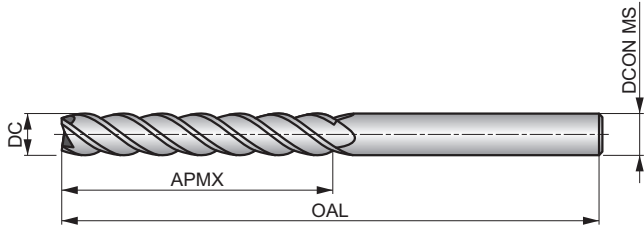

HM	N	NOF 4
	λ 40°	γ 10°
DIN 6535HA	AlCrN	DC h9



Adéquation du groupe de matériaux de la pièce, valeurs de départ pour la vitesse de coupe (m/min) et code alpha. Tableaux d'avances par dent et facteurs de correction à partir de la page 266.

P1.1 ■ 88 J	P1.2 ■ 98 J	P1.3 ■ 101 J	P2.1 ■ 75 J	P2.2 ■ 66 J	P2.3 ■ 59 I	P3.1 ■ 61 J	P3.2 ■ 49 I	P3.3 ■ 41 I	P4.1 ■ 36 I	P4.2 ■ 31 I	M1.1 ■ 50 J	M1.2 ■ 42 J	M2.1 ■ 44 J
M2.2 ■ 36 I	M3.1 ■ 41 I	M3.2 ■ 35 I	K1.1 ■ 86 J	K1.2 ■ 64 J	K1.3 ■ 48 J	K2.1 ■ 89 J	K2.2 ■ 72 J	K2.3 ■ 58 I	K3.1 ■ 79 J	K3.2 ■ 60 J	K3.3 ■ 49 I	K4.1 ■ 73 I	K4.2 ■ 55 I
K4.3 ■ 40 I	K4.4 ■ 35 I	K4.5 ■ 29 I	K5.1 ■ 83 I	K5.2 ■ 62 I	K5.3 ■ 48 I	N1.1 ▣ 178 K	N1.2 ▣ 134 K	N1.3 ▣ 190 K	N2.1 ▣ 190 J	N2.2 ▣ 180 J	N2.3 ▣ 158 J	N3.1 ▣ 194 J	N3.2 ▣ 155 J
N3.3 ▣ 28 J	S1.2 ■ 30 I	S2.1 ■ 23 I	S3.1 ■ 18 I	S4.1 ■ 14 I									

DCON MS tolérance h6.

Product	DC (mm)	DCON MS (mm)	APMX (mm)	OAL (mm)	NOF
S7183.0	3.00	3.00	25.00	100.0	4
S7184.0	4.00	4.00	31.00	100.0	4
S7185.0	5.00	5.00	31.00	100.0	4
S7186.0	6.00	6.00	38.00	100.0	4
S7188.0	8.00	8.00	41.00	100.0	4
S71810.0	10.00	10.00	57.00	125.0	4
S71812.0	12.00	12.00	75.00	150.0	4
S71814.0	14.00	14.00	75.00	150.0	4
S71816.0	16.00	16.00	75.00	150.0	4
S71818.0	18.00	18.00	75.00	150.0	4
S71820.0	20.00	20.00	75.00	150.0	4



OUTILS EN CARBURE MONOBLOC POUR DES PROCESSUS PRODUCTIFS ET SÉCURISÉS. GÉNÉRALEMENT UTILISÉS AVEC DES MACHINES À COMMANDE NUMÉRIQUE ET POUR LA FABRICATION AUTOMATISÉE.

Code de matériau du corps (BMC)	HM	HM																		
Profil de fraise	N	N																		
Nombre de goujures (NOF)	NOF 2	NOF 2																		
Longueur de coupe																				
Angle d'hélice de goujure (FHA)	λ 40°	λ 40°																		
Angle d'hélice de goujure (FHA)	λ 40°	λ 40°																		
Angle de coupe radial (GAMF)	γ 10°	γ 10°																		
Queue																				
Revêtement																				
Classe de tolérance du diamètre de coupe (TCDC)	DC h9	DC h9																		
Direction de coupe																				
Groupe standard de base (BSG)																				

Code de famille de produits	S739	S740																		
Plage de diamètres de coupe PSF	3.00 – 20.00	3.00 – 20.00																		
	106	107																		
P	P1	■	■																	
	P2	■	■																	
	P3	■	■																	
	P4	■	■																	
M	M1	■	■																	
	M2	■	■																	
	M3	■	■																	
	M4	■	■																	
K	K1	■	■																	
	K2	■	■																	
	K3	■	■																	
	K4	■	■																	
	K5	■	■																	
N	N1	■	■																	
	N2	■	■																	
	N3	■	■																	
	N4	■	■																	
	N5	■	■																	
S	S1	■	■																	
	S2	■	■																	
	S3	■	■																	
	S4	■	■																	
H	H1	■	■																	
	H2	■	■																	
	H3	■	■																	
	H4	■	■																	

S739

DORMER



Fraise à chanfreiner à 60° en carbure monobloc à 2 dents

Fraise à 2 dents avec une longueur de coupe courte assurant une grande rigidité et réduisant les vibrations. La pointe à 60° est conçue pour le fraisage de chanfreins sur les machines CNC. Le revêtement ALTiN augmente la durée de vie de l'outil et améliore les performances.

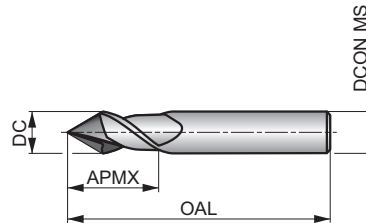

HM	N	NOF 2
	λ 40°	γ 10°
DIN 6535HA	ALTiN	DC h9
	DORMER	



Adéquation du groupe de matériaux de la pièce, valeurs de départ pour la vitesse de coupe (m/min) et code alpha. Tableaux d'avances par dent et facteurs de correction à partir de la page 266.

P1.1 ■ 199 K	P1.2 ■ 223 K	P1.3 ■ 230 K	P2.1 ■ 170 K	P2.2 ■ 150 K	P2.3 ■ 133 J	P3.1 ■ 138 K	P3.2 ■ 111 J	P3.3 ■ 94 J	P4.1 ■ 82 J	P4.2 ■ 70 J	M1.1 ■ 115 K	M1.2 ■ 97 K	M2.1 ■ 102 K
M2.2 ■ 84 J	M3.1 ■ 94 J	M3.2 ■ 81 J	K1.1 ■ 196 K	K1.2 ■ 145 K	K1.3 ■ 109 K	K2.1 ■ 202 K	K2.2 ■ 164 K	K2.3 ■ 131 J	K3.1 ■ 178 K	K3.2 ■ 136 K	K3.3 ■ 110 J	K4.1 ■ 165 J	K4.2 ■ 125 J
K4.3 ■ 91 J	K4.4 ■ 78 J	K4.5 ■ 65 J	K5.1 ■ 187 J	K5.2 ■ 141 J	K5.3 ■ 109 J	N1.1 ■ 355 N	N1.2 ■ 267 N	N1.3 ■ 179 N	N2.1 ■ 179 K	N2.2 ■ 160 K	N2.3 ■ 115 K	N3.1 ■ 187 K	N3.2 ■ 109 K
N3.3 ■ 56 K	S1.2 ■ 69 J	S2.1 ■ 53 J	S3.1 ■ 40 J	S4.1 ■ 31 J									

DCON MS tolérance h6.

Product	KAPR (°)	DC (mm)	DCON MS (mm)	APMX (mm)	OAL (mm)	NOF
S7393.0	60	3.00	3.00	9.00	40.0	2
S7394.0	60	4.00	4.00	12.00	50.0	2
S7395.0	60	5.00	5.00	15.00	50.0	2
S7396.0	60	6.00	6.00	16.00	50.0	2
S7398.0	60	8.00	8.00	20.00	64.0	2
S73910.0	60	10.00	10.00	22.00	70.0	2
S73912.0	60	12.00	12.00	25.00	75.0	2
S73916.0	60	16.00	16.00	32.00	90.0	2
S73920.0	60	20.00	20.00	38.00	100.0	2

S740

DORMER



Fraise à chanfreiner à 90° en carbure monobloc à 2 dents

Fraise à 2 dents avec une longueur de coupe courte assurant une grande rigidité et réduisant les vibrations. La pointe à 90° est conçue pour le fraisage de chanfreins sur les machines CNC. Le revêtement ALTiN augmente la durée de vie de l'outil et améliore les performances.

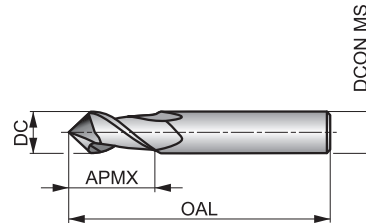

HM	N	NOF 2
	λ 40°	γ 10°
DIN 6335HA	ALTiN	DC h9
	DORMER	

Adéquation du groupe de matériaux de la pièce, valeurs de départ pour la vitesse de coupe (m/min) et code alpha. Tableaux d'avances par dent et facteurs de correction à partir de la page 266.

P1.1 ■ 199 K	P1.2 ■ 223 K	P1.3 ■ 230 K	P2.1 ■ 170 K	P2.2 ■ 150 K	P2.3 ■ 133 J	P3.1 ■ 138 K	P3.2 ■ 111 J	P3.3 ■ 94 J	P4.1 ■ 82 J	P4.2 ■ 70 J	M1.1 ■ 115 K	M1.2 ■ 97 K	M2.1 ■ 102 K
M2.2 ■ 84 J	M3.1 ■ 94 J	M3.2 ■ 81 J	K1.1 ■ 196 K	K1.2 ■ 145 K	K1.3 ■ 109 K	K2.1 ■ 202 K	K2.2 ■ 164 K	K2.3 ■ 131 J	K3.1 ■ 178 K	K3.2 ■ 136 K	K3.3 ■ 110 J	K4.1 ■ 165 J	K4.2 ■ 125 J
K4.3 ■ 91 J	K4.4 ■ 78 J	K4.5 ■ 65 J	K5.1 ■ 187 J	K5.2 ■ 141 J	K5.3 ■ 109 J	N1.1 ■ 355 N	N1.2 ■ 267 N	N1.3 ■ 179 N	N2.1 ■ 179 K	N2.2 ■ 160 K	N2.3 ■ 115 K	N3.1 ■ 187 K	N3.2 ■ 109 K
N3.3 ■ 56 K	S1.2 ■ 69 J	S2.1 ■ 53 J	S3.1 ■ 40 J	S4.1 ■ 31 J									

DCON MS tolérance h6.

Product	KAPR (°)	DC (mm)	DCON MS (mm)	APMX (mm)	OAL (mm)	NOF
S7403.0	90	3.00	3.00	9.00	40.0	2
S7404.0	90	4.00	4.00	12.00	50.0	2
S7405.0	90	5.00	5.00	15.00	50.0	2
S7406.0	90	6.00	6.00	16.00	50.0	2
S7408.0	90	8.00	8.00	20.00	64.0	2
S74010.0	90	10.00	10.00	22.00	70.0	2
S74012.0	90	12.00	12.00	25.00	75.0	2
S74016.0	90	16.00	16.00	32.00	90.0	2
S74020.0	90	20.00	20.00	38.00	100.0	2

Code de matériau du corps (BMC)	HM	HM	HM	HM	HM	HM	HM	HM	HM	HM		
Profil de fraise	NRA	NRA	W	W	W	W	W	W	W	N		
Nombre de goujures (NOF)	NOF 4 \neq	NOF 4 \neq	NOF 1	NOF 2	NOF 2	NOF 2	NOF 3 \neq	NOF 3 \neq	NOF 3	NOF 4-6		
Longueur de coupe												
Angle d'hélice de goujure (FHA)	λ 40°	λ 40°	λ 25°	λ 30°	λ 30°	λ 30°	λ 40°	λ 40°	λ 40°	λ 25°		
Angle d'hélice de goujure (FHA)	λ 40°	λ 40°	λ 25°	λ 30°	λ 30°	λ 30°	λ 40°	λ 40°	λ 40°	λ 25°		
Angle de coupe radial (GAMF)	γ 10°	γ 10°	γ 20°	γ 20°	γ 20°	γ 20°	γ 13°	γ 15°	γ 13°	γ 0°		
Queue												
Revêtement	AlCN	AlCN	Hi	Hi	Hi	Hi	Bright	Bright	Bright	TiSiN		
Classe de tolérance du diamètre de coupe (TCDC)	DC h9	DC h9	DC h9	DC h9	DC h9	DC h9	DC h9	DC h9	DC h9	DC h9		
Direction de coupe												
Groupe standard de base (BSG)												

Code de famille de produits	S765	S765HB	S637	S610	S611	S638	S650	S654	S614	S536		
Plage de diamètres de coupe PSF	6.00 – 20.00	6.00 – 20.00	2.00 – 12.00	2.00 – 20.00	3.00 – 20.00	6.20 – 20.30	1.00 – 20.00	6.00 – 20.00	3.00 – 16.00	6.00 – 12.00		
	110	111	112	113	114	115	116	117	118	119		

P	P1	■	■									
	P2	■	■									
	P3	■	■									
	P4	■	■									
M	M1	■	■									
	M2	■	■									
	M3	■	■									
	M4											
K	K1	■	■									
	K2	■	■									
	K3	■	■									
	K4	■	■									
	K5	■	■									
N	N1			■	■	■	■	■	■	■		
	N2			■	■	■	■	■	■	■		
	N3			■	■	■	■	■	■	■		
	N4			■	■	■	■	■	■	■		
	N5											
S	S1	■	■									
	S2	■	■									
	S3	■	■									
	S4	■	■									
H	H1									■		
	H2									■		
	H3									■		
	H4									■		

S765

DORMER



Fraise d'ébauche en carbure monobloc à 4 dents, queue HA DIN 6535

Fraise à 4 dents avec hélice à 40°, un pas différentiel et une longueur de coupe courte réduisant les vibrations. Le profil NRA, conçu pour briser les copeaux, autorise des applications d'ébauche efficaces. Le revêtement AlCrN améliore les performances et prolonge la durée de vie de l'outil. Convient également aux opérations de rainurage et d'ébauche trochoidale.

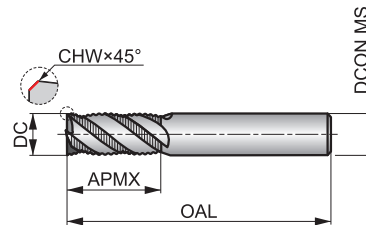

HM	NRA	NOF 4#
	λ 40°	γ 10°
DIN 6535HA	AlCrN	DC h9

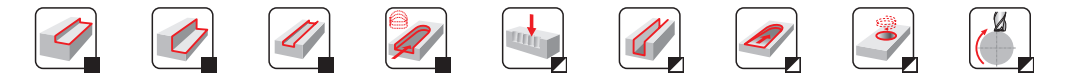

Adéquation du groupe de matériaux de la pièce, valeurs de départ pour la vitesse de coupe (m/min) et code alpha. Tableaux d'avances par dent et facteurs de correction à partir de la page 266.

P1.1 ■ 211 J	P1.2 ■ 236 J	P1.3 ■ 243 J	P2.1 ■ 180 J	P2.2 ■ 158 J	P2.3 ■ 140 J	P3.1 ■ 146 J	P3.2 ■ 117 J	P3.3 ■ 99 J	P4.1 ■ 86 J	P4.2 ■ 74 J	M1.1 ■ 122 J	M1.2 ■ 103 J	M2.1 ■ 108 J
M2.2 ■ 89 J	M3.1 ■ 100 J	M3.2 ■ 86 J	K1.1 ■ 208 J	K1.2 ■ 154 J	K1.3 ■ 116 J	K2.1 ■ 214 J	K2.2 ■ 174 J	K2.3 ■ 139 J	K3.1 ■ 189 J	K3.2 ■ 145 J	K3.3 ■ 117 J	K4.1 ■ 176 J	K4.2 ■ 132 J
K4.3 ■ 97 J	K4.4 ■ 83 I	K4.5 ■ 69 I	K5.1 ■ 199 J	K5.2 ■ 149 J	K5.3 ■ 116 J	S1.2 ■ 72 J	S2.1 ■ 56 I	S3.1 ■ 42 I	S4.1 ■ 33 I				

DCON MS tolérance h6; CHW ±0.02×45° mm.

Product	DC (mm)	CHW (mm)	DCON MS (mm)	APMX (mm)	OAL (mm)	NOF
S7656.0	6.00	0.10	6.00	16.00	50.0	4
S7658.0	8.00	0.20	8.00	20.00	64.0	4
S76510.0	10.00	0.20	10.00	22.00	70.0	4
S76512.0	12.00	0.20	12.00	26.00	75.0	4
S76514.0	14.00	0.30	14.00	32.00	90.0	4
S76516.0	16.00	0.30	16.00	32.00	90.0	4
S76518.0	18.00	0.30	18.00	38.00	100.0	4
S76520.0	20.00	0.40	20.00	38.00	100.0	4

S765HB



Fraise d'ébauche en carbure monobloc à 4 dents, queue HB DIN 6535

Fraise à 4 dents avec hélice à 40°, un pas différentiel et une longueur de coupe courte réduisant les vibrations. Le profil NRA, conçu pour briser les copeaux, autorise des applications d'ébauche efficaces. La queue Weldon empêche la fraise de glisser dans le porte-outil. Revêtement AlCrN. Convient également aux opérations de rainurage et d'ébauche trochoidale.

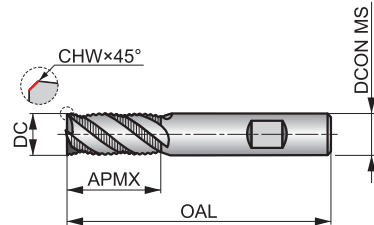

Adéquation du groupe de matériaux de la pièce, valeurs de départ pour la vitesse de coupe (m/min) et code alpha. Tableaux d'avances par dent et facteurs de correction à partir de la page 266.

P1.1 ■ 211 J	P1.2 ■ 236 J	P1.3 ■ 243 J	P2.1 ■ 180 J	P2.2 ■ 158 J	P2.3 ■ 140 J	P3.1 ■ 146 J	P3.2 ■ 117 J	P3.3 ■ 99 J	P4.1 ■ 86 J	P4.2 ■ 74 J	M1.1 ■ 122 J	M1.2 ■ 103 J	M2.1 ■ 108 J
M2.2 ■ 89 J	M3.1 ■ 100 J	M3.2 ■ 86 J	K1.1 ■ 208 J	K1.2 ■ 154 J	K1.3 ■ 116 J	K2.1 ■ 214 J	K2.2 ■ 174 J	K2.3 ■ 139 J	K3.1 ■ 189 J	K3.2 ■ 145 J	K3.3 ■ 117 J	K4.1 ■ 176 J	K4.2 ■ 132 J
K4.3 ■ 97 J	K4.4 ■ 83 I	K4.5 ■ 69 I	K5.1 ■ 199 J	K5.2 ■ 149 J	K5.3 ■ 116 J	S1.2 ■ 72 J	S2.1 ■ 56 I	S3.1 ■ 42 I	S4.1 ■ 33 I				

DCON MS tolérance h6; CHW ±0.02×45° mm.

Product	DC (mm)	CHW (mm)	DCON MS (mm)	APMX (mm)	OAL (mm)	NOF
S765HB6.0	6.00	0.10	6.00	16.00	50.0	4
S765HB8.0	8.00	0.20	8.00	20.00	64.0	4
S765HB10.0	10.00	0.20	10.00	22.00	70.0	4
S765HB12.0	12.00	0.20	12.00	26.00	75.0	4
S765HB14.0	14.00	0.30	14.00	32.00	90.0	4
S765HB16.0	16.00	0.30	16.00	32.00	90.0	4
S765HB18.0	18.00	0.30	18.00	38.00	100.0	4
S765HB20.0	20.00	0.40	20.00	38.00	100.0	4

S637



Fraise à rainurer en carbure monobloc à 1 dent

Fraise à une seule dent avec une longueur de coupe courte offrant des performances élevées lors du rainurage et du découpage. La S637, avec sa géométrie à arêtes vives est conçue pour le rainurage à grande vitesse dans les matériaux non-ferreux à paroi mince. La surface polie empêche le matériau de la pièce de coller aux arêtes de coupe de l'outil.

HM	W	NOF 1
	λ 25°	γ 20°
DIN 6335HA	Hi	DC h9
	DORMER	

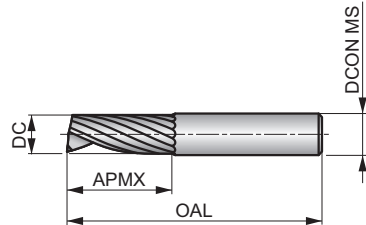

Adéquation du groupe de matériaux de la pièce, valeurs de départ pour la vitesse de coupe (m/min) et code alpha. Tableaux d'avances par dent et facteurs de correction à partir de la page 266.

N1.1 ■ 709 R	N1.2 ■ 533 R	N1.3 ■ 357 R	N2.1 ■ 357 P	N2.2 ■ 320 P	N2.3 ■ 229 P	N3.1 ■ 373 P	N3.2 ■ 219 P	N3.3 ■ 112 P	N4.1 ■ 373 S	N4.2 ■ 144 S
------------------------	------------------------	------------------------	------------------------	------------------------	------------------------	------------------------	------------------------	------------------------	------------------------	------------------------

DCON MS tolérance h6.

Product	DC (mm)	DCON MS (mm)	APMX (mm)	OAL (mm)	NOF
S6372.0	2.00	2.00	10.00	40.0	1
S6373.0	3.00	3.00	12.00	40.0	1
S6374.0	4.00	4.00	15.00	50.0	1
S6375.0	5.00	5.00	16.00	50.0	1
S6376.0	6.00	6.00	20.00	60.0	1
S6378.0	8.00	8.00	22.00	63.0	1
S63710.0	10.00	10.00	25.00	72.0	1
S63712.0	12.00	12.00	30.00	83.0	1

S610

DORMER



Fraise à rainurer en carbure monobloc à 2 dents

Fraise à 2 dents avec une longueur de coupe courte offrant une grande rigidité pour le fraisage de profils et de rainures standards. La S610, avec sa géométrie à arêtes vives, est conçue pour un usinage de haute performance dans les matériaux non-ferreux. La surface polie empêche le matériau de la pièce de coller aux arêtes de coupe de l'outil.

HM	W	NOF 2
	λ 30°	γ 20°
DIN 6358A	Hi	DC h9
	DORMER	

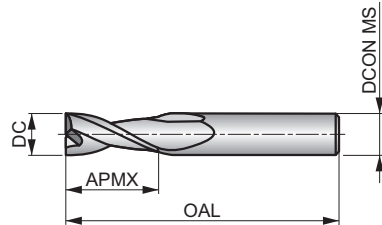

Adéquation du groupe de matériaux de la pièce, valeurs de départ pour la vitesse de coupe (m/min) et code alpha. Tableaux d'avances par dent et facteurs de correction à partir de la page 266.

N1.1 ■ 709 P	N1.2 ■ 533 P	N1.3 ■ 357 P	N2.1 ■ 357 O	N2.2 ■ 320 O	N2.3 ■ 229 O	N3.1 ■ 373 O	N3.2 ■ 219 O	N3.3 ■ 112 O	N4.1 ■ 373 R	N4.2 ■ 144 R
------------------------	------------------------	------------------------	------------------------	------------------------	------------------------	------------------------	------------------------	------------------------	------------------------	------------------------

DCON MS tolérance h6; RE ±0.02 mm.

Product	DC (mm)	RE (mm)	DCON MS (mm)	APMX (mm)	OAL (mm)	NOF
S6102.0	2.00	0.10	4.00	6.50	40.0	2
S6103.0XD3	3.00	0.10	3.00	9.00	40.0	2
S6103.0XD6	3.00	0.10	6.00	9.00	50.0	2
S6104.0XD4	4.00	0.10	4.00	12.00	50.0	2
S6104.0XD6	4.00	0.10	6.00	12.00	50.0	2
S6105.0	5.00	0.10	6.00	15.00	50.0	2
S6106.0	6.00	0.10	6.00	20.00	50.0	2
S6108.0	8.00	0.10	8.00	20.00	64.0	2
S61010.0	10.00	0.10	10.00	22.00	75.0	2
S61012.0	12.00	0.10	12.00	25.00	75.0	2
S61014.0	14.00	0.10	14.00	32.00	90.0	2
S61016.0	16.00	0.10	16.00	32.00	90.0	2
S61020.0	20.00	0.10	20.00	38.00	100.0	2

S611

DORMER



Fraise à rainurer en carbure monobloc à 2 dents, portée extra longue

Fraise à 2 dents avec une longueur de coupe courte et un détalonnage offrant une grande rigidité pour le fraisage et le contournage dans les zones difficiles à atteindre. La S611, avec sa géométrie à arêtes vives, est conçue pour un usinage de haute performance dans les matériaux non-ferreux. La surface polie empêche le matériau de la pièce de coller aux arêtes de coupe de l'outil.

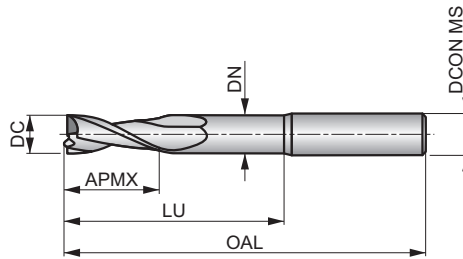

HM	W	NOF 2
	λ 30°	γ 20°
DIN 6535HA	Hi	DC h9



Adéquation du groupe de matériaux de la pièce, valeurs de départ pour la vitesse de coupe (m/min) et code alpha. Tableaux d'avances par dent et facteurs de correction à partir de la page 266.

N1.1 ■ 638 P	N1.2 ■ 480 P	N1.3 ■ 321 P	N2.1 ■ 321 O	N2.2 ■ 288 O	N2.3 ■ 206 O	N3.1 ■ 336 O	N3.2 ■ 197 O	N3.3 ■ 101 O	N4.1 ■ 336 R	N4.2 ■ 130 R
------------------------	------------------------	------------------------	------------------------	------------------------	------------------------	------------------------	------------------------	------------------------	------------------------	------------------------

DCON MS tolérance h6; RE ±0.02 mm.

Product	DC (mm)	RE (mm)	DCON MS (mm)	APMX (mm)	OAL (mm)	NOF	LU (mm)	DN (mm)
S6113.0XD3	3.00	0.10	3.00	9.00	40.0	2	15.00	2.80
S6113.0XD6	3.00	0.10	6.00	9.00	50.0	2	15.00	2.80
S6114.0XD4	4.00	0.10	4.00	12.00	50.0	2	20.00	3.70
S6114.0XD6	4.00	0.10	6.00	12.00	50.0	2	20.00	3.70
S6115.0	5.00	0.10	6.00	15.00	50.0	2	20.00	4.60
S6116.0	6.00	0.10	6.00	16.00	80.0	2	40.00	5.50
S6118.0	8.00	0.10	8.00	20.00	80.0	2	40.00	7.40
S61110.0	10.00	0.10	10.00	22.00	100.0	2	60.00	9.20
S61112.0	12.00	0.10	12.00	25.00	100.0	2	60.00	11.00
S61114.0	14.00	0.10	14.00	32.00	125.0	2	75.00	13.00
S61116.0	16.00	0.10	16.00	32.00	125.0	2	75.00	15.00
S61120.0	20.00	0.10	20.00	38.00	125.0	2	75.00	19.00

S638



Fraise à rainurer en carbure monobloc à 2 dents, portée extra longue

Fraise à 2 dents avec une longueur de coupe extra courte et une queue réduite sur sa totalité pour éviter le talonnage lors de l'usinage de parois profondes. La S638, avec sa géométrie à arêtes vives, est conçue pour l'usinage à grande vitesse dans les matériaux non-ferreux. La surface polie empêche le matériau de la pièce de coller sur les arêtes de coupe de l'outil.

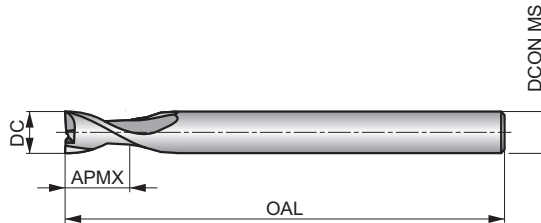

HM	W	NOF 2
	λ 30°	γ 20°
DIN 6535HA	Hi	DC h9



Adéquation du groupe de matériaux de la pièce, valeurs de départ pour la vitesse de coupe (m/min) et code alpha. Tableaux d'avances par dent et facteurs de correction à partir de la page 266.

N1.1	N1.2	N1.3	N2.1	N2.2	N2.3	N3.1	N3.2	N3.3	N4.1	N4.2
■ 709 N	■ 533 N	■ 357 N	■ 357 N	■ 320 N	■ 229 N	■ 373 N	■ 219 N	■ 112 N	■ 373 0	■ 144 0

Queue réduite; DCON MS tolérance h6; RE ±0.02 mm.

Product	DC (mm)	RE (mm)	DCON MS (mm)	APMX (mm)	OAL (mm)	NOF
S6386.2	6.20	0.10	6.00	8.00	100.0	2
S6388.2	8.20	0.10	8.00	10.00	100.0	2
S63810.3	10.30	0.10	10.00	14.00	125.0	2
S63812.3	12.30	0.10	12.00	16.00	125.0	2
S63816.3	16.30	0.10	16.00	20.00	125.0	2
S63820.3	20.30	0.10	20.00	25.00	125.0	2

S650



Fraise à rainurer en carbure monobloc à 3 dents

Fraise à 3 dents à pas différentiel conçue pour réduire les vibrations, la charge de la broche et pour améliorer l'état de surface lors du fraisage. Le brise-copeaux unique sur la dent la plus au centre facilite l'évacuation des copeaux dans les matériaux non-ferreux.

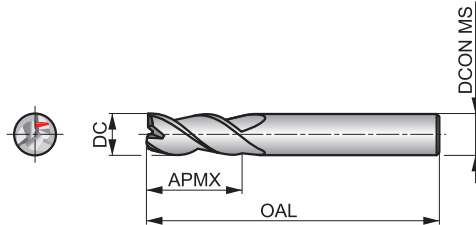

HM	W	NOF 3 \neq
	λ 40°	γ 13°
DIN 6535HA	Bright	DC h9

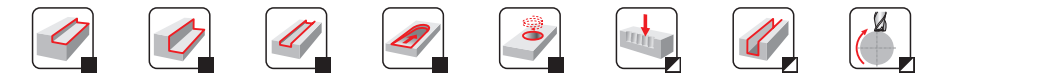

Adéquation du groupe de matériaux de la pièce, valeurs de départ pour la vitesse de coupe (m/min) et code alpha. Tableaux d'avances par dent et facteurs de correction à partir de la page 266.

N1.1 ■ 780 0	N1.2 ■ 608 0	N1.3 ■ 393 0	N2.1 ■ 393 N	N2.2 ■ 352 N	N2.3 ■ 252 N	N3.1 ■ 410 N	N3.2 ■ 241 N	N3.3 ■ 123 N	N4.1 ■ 410 P	N4.2 ■ 158 P
------------------------	------------------------	------------------------	------------------------	------------------------	------------------------	------------------------	------------------------	------------------------	------------------------	------------------------

DCON MS tolérance h6.

Product	DC (mm)	DCON MS (mm)	APMX (mm)	OAL (mm)	NOF
S6501.0	1.00	4.00	3.00	40.0	3
S6501.5	1.50	4.00	4.50	40.0	3
S6502.0	2.00	4.00	6.50	40.0	3
S6502.5	2.50	4.00	6.50	40.0	3
S6503.0XD3	3.00	3.00	9.00	40.0	3
S6503.0XD6	3.00	6.00	9.00	50.0	3
S6504.0XD4	4.00	4.00	12.00	50.0	3
S6504.0XD6	4.00	6.00	12.00	50.0	3
S6505.0	5.00	6.00	15.00	50.0	3
S6506.0	6.00	6.00	16.00	50.0	3
S6508.0	8.00	8.00	20.00	64.0	3
S65010.0	10.00	10.00	22.00	70.0	3
S65012.0	12.00	12.00	25.00	75.0	3
S65014.0	14.00	14.00	32.00	90.0	3
S65016.0	16.00	16.00	32.00	90.0	3
S65020.0 ¹⁾	20.00	20.00	38.00	100.0	3

¹⁾ Pas de pas différentiel et de brise-copeaux.

S654



Fraise d'ébauche en carbure monobloc à 3 dents, longue portée

Fraise à 3 dents à pas différentiel avec une longueur de coupe courte et un détalonnage réduisant les vibrations et maximisant la productivité et la durée de vie de l'outil. La S654, avec son profil NRA, fragmente les copeaux en petits morceaux faciles à évacuer. Elle est conçue pour une ébauche de haute performance dans les matériaux non-ferreux.

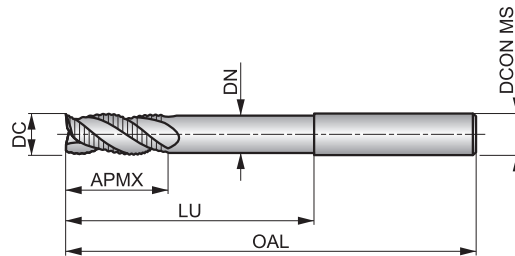

HM	W NRA	NOF 3 \neq
	λ 40°	γ 15°
DIN 6535HA	Bright	DC h9
	DORMER	



Adéquation du groupe de matériaux de la pièce, valeurs de départ pour la vitesse de coupe (m/min) et code alpha. Tableaux d'avances par dent et facteurs de correction à partir de la page 266.

N1.1 ■ 709 0	N1.2 ■ 533 0	N1.3 ■ 357 0	N2.1 ■ 357 N	N2.2 ■ 320 N	N2.3 ■ 229 N	N3.1 ■ 373 N	N3.2 ■ 219 N	N3.3 ■ 112 N	N4.1 ■ 373 P	N4.2 ■ 144 P
------------------------	------------------------	------------------------	------------------------	------------------------	------------------------	------------------------	------------------------	------------------------	------------------------	------------------------

DCON MS tolérance h6; RE ±0.02 mm.

Product	DC (mm)	RE (mm)	DCON MS (mm)	APMX (mm)	OAL (mm)	NOF	LU (mm)	DN (mm)
S6546.0	6.00	0.10	6.00	13.00	75.0	3	40.00	5.50
S6548.0	8.00	0.10	8.00	20.00	75.0	3	40.00	7.40
S65410.0	10.00	0.10	10.00	22.00	100.0	3	60.00	9.20
S65412.0	12.00	0.12	12.00	26.00	100.0	3	60.00	11.00
S65416.0	16.00	0.16	16.00	32.00	125.0	3	75.00	15.00
S65420.0	20.00	0.20	20.00	40.00	150.0	3	100.00	19.00

S614



Fraise à rainurer en carbure monobloc à 3 dents, série extra longue

Fraise à 3 dents avec une longueur de coupe extra longue prévue pour les applications de profilage léger dans les zones difficiles à atteindre. La S614, avec sa géométrie à angle vif, est conçue pour un usinage de haute performance dans les matériaux non-ferreux.

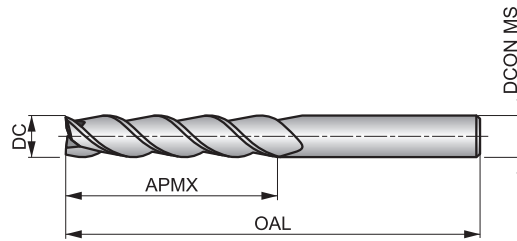

HM	W	NOF 3
	λ 40°	γ 13°
DIN 6335HA	Bright	DC h9

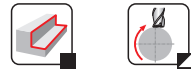

Adéquation du groupe de matériaux de la pièce, valeurs de départ pour la vitesse de coupe (m/min) et code alpha. Tableaux d'avances par dent et facteurs de correction à partir de la page 266.

N1.1	N1.2	N1.3	N2.1	N2.2	N2.3	N3.1	N3.2	N3.3	N4.1	N4.2
■ 638 G	■ 480 G	■ 321 G	■ 321 F	■ 288 F	■ 206 F	■ 336 F	■ 197 F	■ 101 F	■ 336 I	■ 130 I

DCON MS tolérance h6.

Product	DC (mm)	DCON MS (mm)	APMX (mm)	OAL (mm)	NOF
S6143.0XD3	3.00	3.00	19.00	60.0	3
S6143.0XD6	3.00	6.00	19.00	75.0	3
S6144.0XD4	4.00	4.00	19.00	60.0	3
S6144.0XD6	4.00	6.00	19.00	75.0	3
S6145.0	5.00	6.00	19.00	75.0	3
S6146.0	6.00	6.00	31.00	75.0	3
S6148.0	8.00	8.00	41.00	100.0	3
S61410.0	10.00	10.00	50.00	100.0	3
S61412.0	12.00	12.00	50.00	100.0	3
S61414.0	14.00	14.00	57.00	125.0	3
S61416.0	16.00	16.00	57.00	125.0	3

S536

DORMER



Fraise grande avance en carbure monobloc à 4, 6 dents

Fraise à 4 ou 6 dents rayonnées avec hélice à 25° et une géométrie spécifique prévue pour l'usinage grande avance dans les matériaux trempés jusqu'à 63 HRC. Le revêtement TiSiN augmente la durée de vie de l'outil et améliore les performances.

HM	N	NOF 4-6
	λ 25°	γ 0°
DIN 6335HA	TiSiN	DC h9

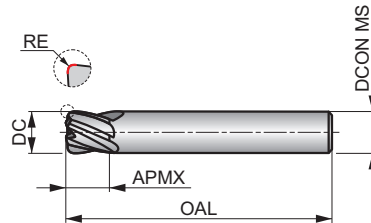

Adéquation du groupe de matériaux de la pièce, valeurs de départ pour la vitesse de coupe (m/min) et code alpha. Tableaux d'avances par dent et facteurs de correction à partir de la page 266.

H1.1	H2.1	H2.2	H3.1	H3.2	H4.1	H4.2
■ 205 E	■ 122 E	■ 104 D	■ 135 E	■ 111 E	■ 86 D	■ 73 D

DCON MS tolérance h6; RE ±0.01 mm.

Product	DC (mm)	RE (mm)	DCON MS (mm)	APMX (mm)	OAL (mm)	NOF
S5366.0XR1.0	6.00	1.00	6.00	6.00	60.0	4
S5368.0XR2.0	8.00	2.00	8.00	8.00	64.0	6
S53610.0XR2.0	10.00	2.00	10.00	10.00	75.0	6
S53612.0XR2.0	12.00	2.00	12.00	12.00	75.0	6

Code de matériau du corps (BMC)	HM	HM	HM	HM															
Profil de fraise	N	FS	N	FS															
Nombre de goujures (NOF)	NOF 5	NOF 5	NOF 5	NOF 5															
Longueur de coupe																			
Angle d'hélice de goujure (FHA)	$\lambda \neq$	$\lambda \neq$	$\lambda \neq$	$\lambda \neq$															
Angle de coupe radial (GAMF)	$\gamma 10^\circ$	$\gamma 10^\circ$	$\gamma 10^\circ$	$\gamma 10^\circ$															
Queue																			
Classe de tolérance du diamètre de coupe (TCDC)	DC h9	DC h9	DC h9	DC h9															
Revêtement	AICN	AICN	AICN	AICN															
Direction de coupe																			
Groupe standard de base (BSG)	DORMER	DORMER	DORMER	DORMER															
Propriété d'alimentation en liquide de coupe (CSP)																			

Code de famille de produits		S770HB	S771HB	S772HB	S773HB														
Plage de diamètres de coupe PSF		10.00 – 20.00	10.00 – 20.00	10.00 – 20.00	10.00 – 20.00														
P	P1	■	■	■	■														
	P2	■	■	■	■														
	P3	■	■	■	■														
	P4	■	■	■	■														
M	M1	■	■	■	■														
	M2	■	■	■	■														
	M3	■	■	■	■														
	M4																		
K	K1	■	■	■	■														
	K2	■	■	■	■														
	K3	■	■	■	■														
	K4	■	■	■	■														
	K5	■	■	■	■														
N	N1																		
	N2																		
	N3																		
	N4																		
	N5																		
S	S1	■	■	■	■														
	S2	■	■	■	■														
	S3	■	■	■	■														
	S4	■	■	■	■														
H	H1																		
	H2																		
	H3																		
	H4																		

S770HB



Fraise trochoïdale en carbure monobloc à 5 dents

Fraise à 5 dents avec hélice variable, une longueur de coupe courte et un détalonnage permettant de réduire les vibrations, notamment lors de l'utilisation avec des stratégies de fraisage dynamique. Le revêtement AlCrN améliore les performances et prolonge la durée de vie de l'outil. Convient pour le fraisage trochoïdal et le contournage, le fraisage en ramping et en interpolation hélicoïdale.

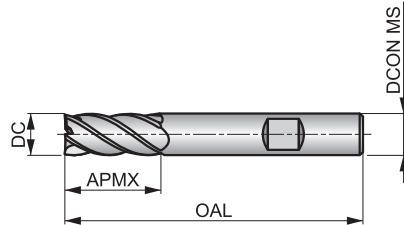

HM	N	NOF 5
	$\lambda \neq$	γ 10°
DIN 6535HB	AlCrN	DC h9
	DORMER	



Adéquation du groupe de matériaux de la pièce, valeurs de départ pour la vitesse de coupe (m/min) et code alpha. Tableaux d'avances par dent et facteurs de correction à partir de la page 266.

P1.1 ■ 211 I	P1.2 ■ 236 I	P1.3 ■ 243 I	P2.1 ■ 180 I	P2.2 ■ 158 I	P2.3 ■ 140 I	P3.1 ■ 146 I	P3.2 ■ 117 I	P3.3 ■ 99 I	P4.1 ■ 86 I	P4.2 ■ 74 I	M1.1 ■ 122 I	M1.2 ■ 103 I	M2.1 ■ 108 I
M2.2 ■ 89 I	M3.1 ■ 100 I	M3.2 ■ 86 I	K1.1 ■ 208 I	K1.2 ■ 154 I	K1.3 ■ 116 I	K2.1 ■ 214 I	K2.2 ■ 174 I	K2.3 ■ 139 I	K3.1 ■ 189 I	K3.2 ■ 145 I	K3.3 ■ 117 I	K4.1 ■ 176 I	K4.2 ■ 132 I
K4.3 ■ 97 I	K4.4 ■ 83 G	K4.5 ■ 69 G	K5.1 ■ 199 I	K5.2 ■ 149 I	K5.3 ■ 116 I	S1.2 ■ 72 I	S2.1 ■ 56 G	S3.1 ■ 42 G	S4.1 ■ 33 G				

DCON MS tolérance h6; RE ±0.01 mm.

Product	DC (mm)	RE (mm)	DCON MS (mm)	APMX (mm)	OAL (mm)	NOF
S770HB10.0	10.00	0.20	10.00	22.00	72.0	5
S770HB12.0	12.00	0.30	12.00	26.00	83.0	5
S770HB16.0	16.00	0.30	16.00	32.00	92.0	5
S770HB20.0	20.00	0.30	20.00	38.00	104.0	5

S771HB

DORMER



Fraise trochoïdale en carbure monobloc à 5 dents avec brise-copeaux, arrosage centralisé

Fraise à 5 dents avec hélice variable, une longueur de coupe courte et un détalonnage permettant de réduire les vibrations, en particulier lors de l'utilisation avec des stratégies de fraisage dynamique. Le revêtement AlCrN améliore les performances et prolonge la durée de vie de l'outil. Le brise-copeaux et l'arrosage centralisé améliorent l'évacuation des copeaux dans les opérations de poche.

HM	FS	NOF 5
	$\lambda \neq$	γ 10°
DIN 6535HB	AlCrN	DC h9
	DORMER	

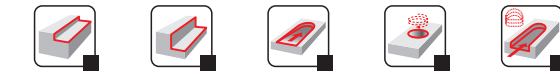
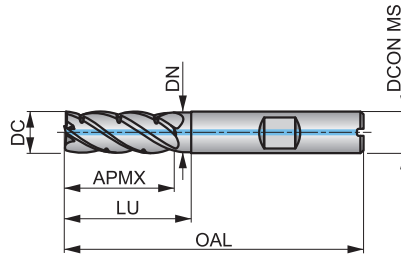

Adéquation du groupe de matériaux de la pièce, valeurs de départ pour la vitesse de coupe (m/min) et code alpha. Tableaux d'avances par dent et facteurs de correction à partir de la page 266.

P1.1 ■ 222 J	P1.2 ■ 248 J	P1.3 ■ 255 J	P2.1 ■ 189 J	P2.2 ■ 166 J	P2.3 ■ 147 I	P3.1 ■ 153 J	P3.2 ■ 123 I	P3.3 ■ 104 I	P4.1 ■ 90 I	P4.2 ■ 78 I	M1.1 ■ 128 I	M1.2 ■ 108 I	M2.1 ■ 113 I
M2.2 ■ 93 I	M3.1 ■ 105 I	M3.2 ■ 90 I	K1.1 ■ 218 J	K1.2 ■ 162 J	K1.3 ■ 122 J	K2.1 ■ 225 J	K2.2 ■ 183 J	K2.3 ■ 146 I	K3.1 ■ 198 J	K3.2 ■ 152 I	K3.3 ■ 123 I	K4.1 ■ 185 I	K4.2 ■ 139 I
K4.3 ■ 102 I	K4.4 ■ 87 I	K4.5 ■ 72 I	K5.1 ■ 209 I	K5.2 ■ 156 I	K5.3 ■ 122 I	S1.2 ■ 76 I	S2.1 ■ 59 I	S3.1 ■ 44 G	S4.1 ■ 35 G				

DCON MS tolérance h6; RE ±0.01 mm.

Product	DC (mm)	RE (mm)	DCON MS (mm)	APMX (mm)	OAL (mm)	NOF	LU (mm)	DN (mm)
S771HB10.0	10.00	0.20	10.00	25.00	72.0	5	30.00	9.70
S771HB12.0	12.00	0.20	12.00	30.00	83.0	5	38.00	11.70
S771HB16.0	16.00	0.30	16.00	39.00	92.0	5	44.00	15.70
S771HB20.0	20.00	0.30	20.00	48.00	104.0	5	54.00	19.70

S772HB



Fraise trochoïdale en carbure monobloc à 5 dents, série longue

Fraise à 5 dents avec hélice variable, une grande longueur de coupe et un détalonnage permettant de réduire les vibrations notamment lors de l'utilisation avec des stratégies de fraisage dynamique. Le revêtement AlCrN améliore les performances et prolonge la durée de vie de l'outil. Convient pour le fraisage trochoïdal et le contournage, le fraisage en ramping et en interpolation hélicoïdale.

HM	N	NOF 5
	$\lambda \neq$	γ 10°
DIN 6535HB	AlCrN	DC h9

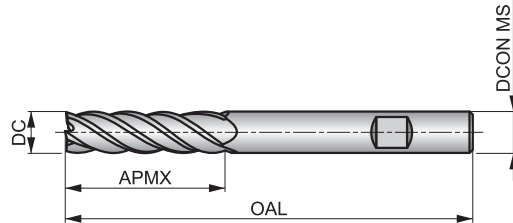

Adéquation du groupe de matériaux de la pièce, valeurs de départ pour la vitesse de coupe (m/min) et code alpha. Tableaux d'avances par dent et facteurs de correction à partir de la page 266.

P1.1 ■ 148 G	P1.2 ■ 165 G	P1.3 ■ 170 G	P2.1 ■ 126 G	P2.2 ■ 111 G	P2.3 ■ 98 F	P3.1 ■ 102 G	P3.2 ■ 82 F	P3.3 ■ 69 F	P4.1 ■ 60 F	P4.2 ■ 52 F	M1.1 ■ 85 G	M1.2 ■ 72 G	M2.1 ■ 76 G
M2.2 ■ 62 G	M3.1 ■ 70 G	M3.2 ■ 60 G	K1.1 ■ 146 G	K1.2 ■ 108 G	K1.3 ■ 81 G	K2.1 ■ 150 G	K2.2 ■ 122 G	K2.3 ■ 97 F	K3.1 ■ 132 G	K3.2 ■ 102 G	K3.3 ■ 82 F	K4.1 ■ 123 F	K4.2 ■ 92 F
K4.3 ■ 68 F	K4.4 ■ 58 G	K4.5 ■ 48 G	K5.1 ■ 139 F	K5.2 ■ 104 F	K5.3 ■ 81 F	S1.2 ■ 50 F	S2.1 ■ 39 F	S3.1 ■ 29 F	S4.1 ■ 23 F				

DCON MS tolérance h6; RE ±0.01 mm.

Product	DC (mm)	RE (mm)	DCON MS (mm)	APMX (mm)	OAL (mm)	NOF
S772HB10.0	10.00	0.20	10.00	38.00	100.0	5
S772HB12.0	12.00	0.30	12.00	45.00	100.0	5
S772HB16.0	16.00	0.30	16.00	55.00	125.0	5
S772HB20.0	20.00	0.30	20.00	65.00	125.0	5

S773HB

DORMER



Fraise trochoïdale en carbure monobloc à 5 dents, série longue avec brise-copeaux, arrosage centralisé
 Fraise à 5 dents avec hélice variable, une grande longueur de coupe et un détalonnage permettant de réduire les vibrations en particulier lors de l'utilisation avec des stratégies de fraisage dynamique. Le revêtement AlCrN améliore les performances et prolonge la durée de vie de l'outil. Le brise-copeaux et l'arrosage centralisé améliorent l'évacuation des copeaux dans les opérations de poche.

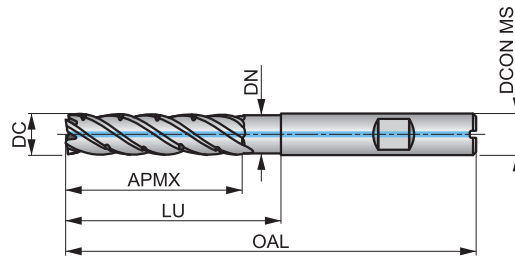

HM	FS	NOF 5
	$\lambda \neq$	γ 10°
DIN 6535HB	AlCrN	DC h9
	DORMER	



Adéquation du groupe de matériaux de la pièce, valeurs de départ pour la vitesse de coupe (m/min) et code alpha. Tableaux d'avances par dent et facteurs de correction à partir de la page 266.

P1.1 ■ 155 G	P1.2 ■ 173 G	P1.3 ■ 179 G	P2.1 ■ 132 G	P2.2 ■ 117 G	P2.3 ■ 103 F	P3.1 ■ 107 G	P3.2 ■ 86 F	P3.3 ■ 72 F	P4.1 ■ 63 F	P4.2 ■ 55 F	M1.1 ■ 89 F	M1.2 ■ 76 F	M2.1 ■ 80 F
M2.2 ■ 65 F	M3.1 ■ 74 F	M3.2 ■ 63 F	K1.1 ■ 153 G	K1.2 ■ 113 G	K1.3 ■ 85 G	K2.1 ■ 158 G	K2.2 ■ 128 G	K2.3 ■ 102 F	K3.1 ■ 139 G	K3.2 ■ 107 G	K3.3 ■ 86 F	K4.1 ■ 129 F	K4.2 ■ 97 F
K4.3 ■ 71 F	K4.4 ■ 61 F	K4.5 ■ 50 F	K5.1 ■ 146 F	K5.2 ■ 109 F	K5.3 ■ 85 F	S1.2 ■ 53 F	S2.1 ■ 41 F	S3.1 ■ 30 F	S4.1 ■ 24 F				

DCON MS tolérance h6; RE ±0.01 mm.

Product	DC (mm)	RE (mm)	DCON MS (mm)	APMX (mm)	OAL (mm)	NOF	LU (mm)	DN (mm)
S773HB10.0	10.00	0.20	10.00	42.00	100.0	5	52.00	9.70
S773HB12.0	12.00	0.20	12.00	42.00	100.0	5	54.00	11.70
S773HB16.0	16.00	0.30	16.00	60.00	125.0	5	68.00	15.70
S773HB20.0	20.00	0.30	20.00	67.00	125.0	5	75.00	19.70

		HM	HM	HM	HM	HM	HM	HM	HM	HM	HM	HM	HM	
Code de matériau du corps (BMC)		HM	HM	HM	HM	HM	HM	HM	HM	HM	HM	HM	HM	
Profil de fraise		N	N	N	N	N	N	N	N	N	W	N	N	
Nombre de goujures (NOF)		NOF 4	NOF 4	NOF 4	NOF 4	NOF 4	NOF 4	NOF 4	NOF 4	NOF 4	NOF 4	NOF 4	NOF 4	
Longueur de coupe														
Angle d'hélice de goujure (FHA)		λ 40°	λ 40°	λ ≠	λ ≠	λ 40°	λ ≠	λ 40°	λ 40°	λ 40°	λ 40°	λ 45°	λ 40°	
Angle d'hélice de goujure (FHA)		λ 40°	λ 40°	λ ≠	λ ≠	λ 40°	λ ≠	λ 40°	λ 40°	λ 40°	λ 40°	λ 45°	λ 40°	
Angle de coupe radial (GAMF)		γ 10°	γ 10°	γ 10°	γ 10°	γ 7°	γ 10°	γ 4°	γ 4°	γ 3°	γ 10°	γ 10°	γ -10°	γ -6°
Queue														
Revêtement		AICN	AICN	TiSiN	TiSiN	AICN	TiSiN	AICN	AICN	AlTiN	Diamond	Bright	TiSiN	TiSiN
Classe de tolérance du diamètre de coupe (TCDC)		DC h9	DC h9	DC h9	DC h9	DC h9	DC h9	DC h9	DC h9	DC h9	DC h9	DC h9	DC h9	DC h9
Direction de coupe														
Groupe standard de base (BSG)		DORMER	DORMER	DORMER	DORMER	DORMER	DORMER	DORMER	DORMER	DORMER	DORMER	DORMER	DORMER	DORMER
Code de famille de produits		S761	S763	S766	S767	S722HB	S768	S260	S262	S219	S612	S662	S521	S523
Plage de diamètres de coupe PSF		3.00 – 20.00	3.00 – 20.00	4.00 – 20.00	4.00 – 20.00	3.00 – 20.00	4.00 – 20.00	3.00 – 20.00	3.00 – 20.00	3.00 – 20.00	1.00 – 12.00	3.00 – 20.00	3.00 – 16.00	1.50 – 16.00
		128	129	130	131	132	133	134	135	137	138	139	140	141
P	P1	■	■	■	■	■	■							
	P2	■	■	■	■	■	■							
	P3	■	■	■	■	■	■							
	P4	■	■	■	■	■	■			▣				
M	M1	■	■	■	■	■	■							
	M2	■	■	■	■	■	■	■	■	■				
	M3	■	■	■	■	■	■	■	■	■				
	M4							■	■	■				
K	K1	■	■	■	■	■	■							
	K2	■	■	■	■	■	■							
	K3	■	■	■	■	■	■							
	K4	■	■	■	■	■	■							
	K5	■	■	■	■	■	■							
N	N1											■		
	N2											■		
	N3											■		
	N4											■		
	N5										■			
S	S1	■	■	■	■	■	■	■	■	■				
	S2	■	■	■	■	■	■	■	■	■				
	S3	■	■	■	■	■	■	■	■	■				
	S4	■	■	■	■	■	■	■	■	■				
H	H1							■	■				■	■
	H2							■	■				■	■
	H3							■	■				■	■
	H4												■	■

■ Utilisation principale ▣ Utilisation possible

ISO
13399PMK
NSH

HM

HM

N

N

 λ
40° λ
40° λ
40° λ
40° γ
-6° γ
-6°DC
h9DC
h9

S524

S561

3.00 – 16.00

1.00 – 20.00

143

144

P1

P2

P3

P4

M1

M2

M3

M4

K1

K2

K3

K4

K5

N1

N2

N3

N4

N5

S1

S2

S3

S4

H1

H2

H3

H4



■ Utilisation principale

▣ Utilisation possible

S761



Fraise de finition en carbure monobloc à 4 dents

Fraise à 4 dents avec hélice à 40°, un pas différentiel et une longueur de coupe courte réduisant les vibrations et améliorant la finition de surface en fraisage de profil. Le revêtement AlCrN améliore les performances et prolonge la durée de vie de l'outil. Convient également pour le tréflage, le fraisage en ramping et trochoidal.

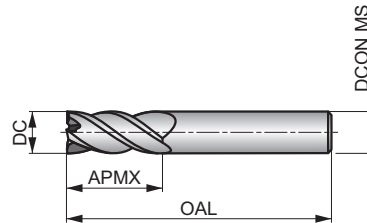

HM	N	NOF 4#
	λ 40°	γ 10°
DIN 6535HA	AlCrN	DC h9



Adéquation du groupe de matériaux de la pièce, valeurs de départ pour la vitesse de coupe (m/min) et code alpha. Tableaux d'avances par dent et facteurs de correction à partir de la page 266.

P1.1 ■ 211 J	P1.2 ■ 236 J	P1.3 ■ 243 J	P2.1 ■ 180 J	P2.2 ■ 158 J	P2.3 ■ 140 I	P3.1 ■ 146 J	P3.2 ■ 117 I	P3.3 ■ 99 I	P4.1 ■ 86 I	P4.2 ■ 74 I	M1.1 ■ 122 J	M1.2 ■ 103 J	M2.1 ■ 108 J
M2.2 ■ 89 I	M3.1 ■ 100 I	M3.2 ■ 86 I	K1.1 ■ 208 J	K1.2 ■ 154 J	K1.3 ■ 116 J	K2.1 ■ 214 J	K2.2 ■ 174 J	K2.3 ■ 139 I	K3.1 ■ 189 J	K3.2 ■ 145 J	K3.3 ■ 117 I	K4.1 ■ 176 I	K4.2 ■ 132 I
K4.3 ■ 97 I	K4.4 ■ 83 I	K4.5 ■ 69 I	K5.1 ■ 199 I	K5.2 ■ 149 I	K5.3 ■ 116 I	S1.2 ■ 72 I	S2.1 ■ 56 I	S3.1 ■ 42 I	S4.1 ■ 33 I				

DCON MS tolérance h6.

Product	DC (mm)	DCON MS (mm)	APMX (mm)	OAL (mm)	NOF
S7613.0	3.00	6.00	9.00	57.0	4
S7614.0	4.00	6.00	12.00	57.0	4
S7615.0	5.00	6.00	13.00	57.0	4
S7616.0	6.00	6.00	13.00	57.0	4
S7618.0	8.00	8.00	20.00	64.0	4
S76110.0	10.00	10.00	22.00	72.0	4
S76112.0	12.00	12.00	26.00	83.0	4
S76114.0	14.00	14.00	32.00	83.0	4
S76116.0	16.00	16.00	32.00	92.0	4
S76120.0	20.00	20.00	38.00	104.0	4

S763

DORMER



Fraise torique en carbure monobloc à 4 dents

Fraise à 4 dents avec hélice à 40°, un pas différentiel, une longueur de coupe courte et différents rayons en bout disponibles réduisant les vibrations et améliorant la finition de surface lors du fraisage de contours où un rayon d'angle est requis. Le revêtement AlCrN améliore les performances. Convient également pour le tréflage, le ramping, l'ébauche en Z et l'interpolation hélicoïdale.

HM	N	NOF 4#
	λ 40°	γ 10°
DIN 6335HA	AlCrN	DC h9

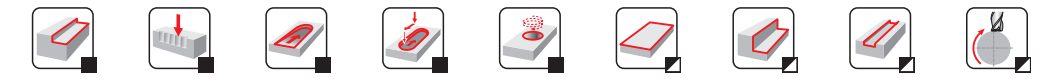
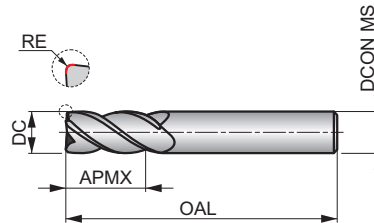

Adéquation du groupe de matériaux de la pièce, valeurs de départ pour la vitesse de coupe (m/min) et code alpha. Tableaux d'avances par dent et facteurs de correction à partir de la page 266.

P1.1 ■ 211 J	P1.2 ■ 236 J	P1.3 ■ 243 J	P2.1 ■ 180 J	P2.2 ■ 158 J	P2.3 ■ 140 I	P3.1 ■ 146 J	P3.2 ■ 117 I	P3.3 ■ 99 I	P4.1 ■ 86 I	P4.2 ■ 74 I	M1.1 ■ 122 J	M1.2 ■ 103 J	M2.1 ■ 108 J
M2.2 ■ 89 I	M3.1 ■ 100 I	M3.2 ■ 86 I	K1.1 ■ 208 J	K1.2 ■ 154 J	K1.3 ■ 116 J	K2.1 ■ 214 J	K2.2 ■ 174 J	K2.3 ■ 139 I	K3.1 ■ 189 J	K3.2 ■ 145 J	K3.3 ■ 117 I	K4.1 ■ 176 I	K4.2 ■ 132 I
K4.3 ■ 97 I	K4.4 ■ 83 I	K4.5 ■ 69 I	K5.1 ■ 199 I	K5.2 ■ 149 I	K5.3 ■ 116 I	S1.2 ■ 72 I	S2.1 ■ 56 I	S3.1 ■ 42 I	S4.1 ■ 33 I				

DCON MS tolérance h6; RE ±0.01 mm.

Product	DC (mm)	RE (mm)	DCON MS (mm)	APMX (mm)	OAL (mm)	NOF
S7633.0XR0.3	3.00	0.30	3.00	9.00	40.0	4
S7634.0XR0.3	4.00	0.30	4.00	12.00	50.0	4
S7634.0XR0.5	4.00	0.50	4.00	12.00	50.0	4
S7635.0XR0.3	5.00	0.30	5.00	15.00	50.0	4
S7635.0XR0.5	5.00	0.50	5.00	15.00	50.0	4
S7636.0XR0.5	6.00	0.50	6.00	16.00	50.0	4
S7636.0XR1.0	6.00	1.00	6.00	16.00	50.0	4
S7638.0XR0.5	8.00	0.50	8.00	20.00	64.0	4
S7638.0XR1.0	8.00	1.00	8.00	20.00	64.0	4
S76310.0XR0.5	10.00	0.50	10.00	22.00	70.0	4
S76310.0XR1.0	10.00	1.00	10.00	22.00	70.0	4
S76310.0XR2.0	10.00	2.00	10.00	22.00	70.0	4
S76312.0XR1.0	12.00	1.00	12.00	25.00	75.0	4
S76312.0XR2.0	12.00	2.00	12.00	25.00	75.0	4
S76312.0XR3.0	12.00	3.00	12.00	25.00	75.0	4
S76314.0XR1.5	14.00	1.50	14.00	32.00	90.0	4
S76316.0XR1.0	16.00	1.00	16.00	32.00	90.0	4
S76316.0XR2.0	16.00	2.00	16.00	32.00	90.0	4
S76316.0XR3.0	16.00	3.00	16.00	32.00	90.0	4
S76318.0XR2.0	18.00	2.00	18.00	38.00	100.0	4
S76320.0XR3.0	20.00	3.00	20.00	38.00	100.0	4

S766

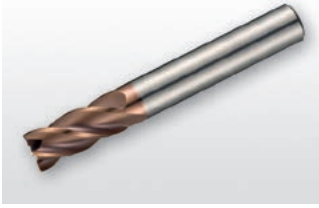

Fraise de finition en carbure monobloc à 4 dents

Fraise à 4 dents avec hélice variable, un pas différentiel et une longueur de coupe courte réduisant les vibrations et améliorant la finition de surface en fraisage de profil. Le revêtement TiSiN augmente la durée de vie de l'outil et améliore les performances. Convient également pour le tréflage, le fraisage en ramping et trochoidal.

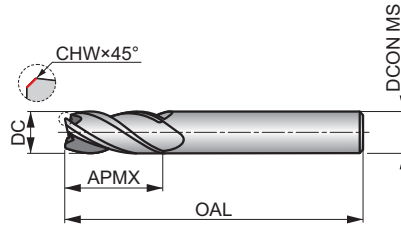

HM	N	NOF 4#
	$\lambda \neq$	γ 10°
DIN 6535HA	TiSiN	DC h9



Adéquation du groupe de matériaux de la pièce, valeurs de départ pour la vitesse de coupe (m/min) et code alpha. Tableaux d'avances par dent et facteurs de correction à partir de la page 266.

P1.1 ■ 211 J	P1.2 ■ 236 J	P1.3 ■ 243 J	P2.1 ■ 180 J	P2.2 ■ 158 J	P2.3 ■ 140 I	P3.1 ■ 146 J	P3.2 ■ 117 I	P3.3 ■ 99 I	P4.1 ■ 86 I	P4.2 ■ 74 I	M1.1 ■ 122 J	M1.2 ■ 103 J	M2.1 ■ 108 J
M2.2 ■ 89 I	M3.1 ■ 100 I	M3.2 ■ 86 I	K1.1 ■ 208 J	K1.2 ■ 154 J	K1.3 ■ 116 J	K2.1 ■ 214 J	K2.2 ■ 174 J	K2.3 ■ 139 I	K3.1 ■ 189 J	K3.2 ■ 145 J	K3.3 ■ 117 I	K4.1 ■ 176 I	K4.2 ■ 132 I
K4.3 ■ 97 I	K4.4 ■ 83 I	K4.5 ■ 69 I	K5.1 ■ 199 I	K5.2 ■ 149 I	K5.3 ■ 116 I	S1.2 ■ 72 I	S2.1 ■ 56 I	S3.1 ■ 42 I	S4.1 ■ 33 I				

DCON MS tolérance h6; CHW ±0.02X45° mm.

Product	DC (mm)	CHW (mm)	DCON MS (mm)	APMX (mm)	OAL (mm)	NOF
S7664.0	4.00	0.10	6.00	11.00	57.0	4
S7665.0	5.00	0.10	6.00	13.00	57.0	4
S7666.0	6.00	0.10	6.00	13.00	57.0	4
S7668.0	8.00	0.20	8.00	20.00	64.0	4
S76610.0	10.00	0.20	10.00	22.00	72.0	4
S76612.0	12.00	0.20	12.00	26.00	83.0	4
S76614.0	14.00	0.30	14.00	26.00	83.0	4
S76616.0	16.00	0.30	16.00	32.00	92.0	4
S76620.0	20.00	0.40	20.00	38.00	104.0	4

S767

DORMER



Fraise torique en carbure monobloc à 4 dents

Fraise à 4 dents avec hélice variable, un pas différentiel, une longueur de coupe courte et différents rayons en bout disponibles réduisant les vibrations et améliorant la finition de surface lors du fraisage de contours où un rayon d'angle est requis. Le revêtement TiSiN améliore les performances. Convient également pour le tréflage, le fraisage en ramping et trochoidal.

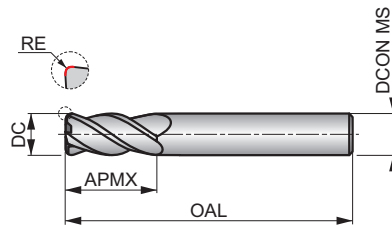

HM	N	NOF 4#
	$\lambda \neq$	γ 10°
DIN 6535HA	TiSiN	DC h9



Adéquation du groupe de matériaux de la pièce, valeurs de départ pour la vitesse de coupe (m/min) et code alpha. Tableaux d'avances par dent et facteurs de correction à partir de la page 266.

P1.1 ■ 211 J	P1.2 ■ 236 J	P1.3 ■ 243 J	P2.1 ■ 180 J	P2.2 ■ 158 J	P2.3 ■ 140 I	P3.1 ■ 146 J	P3.2 ■ 117 I	P3.3 ■ 99 I	P4.1 ■ 86 I	P4.2 ■ 74 I	M1.1 ■ 122 J	M1.2 ■ 103 J	M2.1 ■ 108 J
M2.2 ■ 89 I	M3.1 ■ 100 I	M3.2 ■ 86 I	K1.1 ■ 208 J	K1.2 ■ 154 J	K1.3 ■ 116 J	K2.1 ■ 214 J	K2.2 ■ 174 J	K2.3 ■ 139 I	K3.1 ■ 189 J	K3.2 ■ 145 J	K3.3 ■ 117 I	K4.1 ■ 176 I	K4.2 ■ 132 I
K4.3 ■ 97 I	K4.4 ■ 83 I	K4.5 ■ 69 I	K5.1 ■ 199 I	K5.2 ■ 149 I	K5.3 ■ 116 I	S1.2 ■ 72 I	S2.1 ■ 56 I	S3.1 ■ 42 I	S4.1 ■ 33 I				

DCON MS tolérance h6; RE ±0.01 mm.

Product	DC (mm)	RE (mm)	DCON MS (mm)	APMX (mm)	OAL (mm)	NOF
S7674.0XR0.3	4.00	0.30	6.00	11.00	57.0	4
S7674.0XR0.5	4.00	0.50	6.00	11.00	57.0	4
S7675.0XR0.3	5.00	0.30	6.00	13.00	57.0	4
S7675.0XR0.5	5.00	0.50	6.00	13.00	57.0	4
S7676.0XR0.3	6.00	0.30	6.00	13.00	57.0	4
S7676.0XR0.5	6.00	0.50	6.00	13.00	57.0	4
S7676.0XR1.0	6.00	1.00	6.00	13.00	57.0	4
S7678.0XR0.3	8.00	0.30	8.00	20.00	64.0	4
S7678.0XR0.5	8.00	0.50	8.00	20.00	64.0	4
S7678.0XR1.0	8.00	1.00	8.00	20.00	64.0	4
S76710.0XR0.3	10.00	0.30	10.00	22.00	72.0	4
S76710.0XR0.5	10.00	0.50	10.00	22.00	72.0	4
S76710.0XR1.0	10.00	1.00	10.00	22.00	72.0	4
S76712.0XR0.3	12.00	0.30	12.00	26.00	83.0	4
S76712.0XR0.5	12.00	0.50	12.00	26.00	83.0	4
S76712.0XR1.0	12.00	1.00	12.00	26.00	83.0	4
S76712.0XR2.0	12.00	2.00	12.00	26.00	83.0	4
S76716.0XR0.3	16.00	0.30	16.00	32.00	92.0	4
S76716.0XR0.5	16.00	0.50	16.00	32.00	92.0	4
S76716.0XR1.0	16.00	1.00	16.00	32.00	92.0	4
S76716.0XR2.0	16.00	2.00	16.00	32.00	92.0	4
S76720.0XR0.3	20.00	0.30	20.00	38.00	104.0	4
S76720.0XR0.5	20.00	0.50	20.00	38.00	104.0	4
S76720.0XR1.0	20.00	1.00	20.00	38.00	104.0	4
S76720.0XR2.0	20.00	2.00	20.00	38.00	104.0	4

S722HB

DORMER



Fraise de finition en carbure monobloc à 4 dents

Fraise à 4 dents avec hélice à 40°, une longueur de coupe moyenne, un pas différentiel et une queue Weldon offrant une grande rigidité pour le fraisage de profil sur des parois profondes. Le détalonnage de la queue évite le contact de la fraise avec la paroi et augmente la portée. Le revêtement AlCrN améliore les performances et prolonge la durée de vie de l'outil.

HM	N	NOF 4 \pm
	λ 40°	γ 7°
DIN 6535HB	AlCrN	DC h9

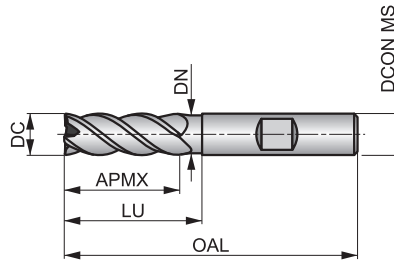

Adéquation du groupe de matériaux de la pièce, valeurs de départ pour la vitesse de coupe (m/min) et code alpha. Tableaux d'avances par dent et facteurs de correction à partir de la page 266.

P1.1 ■ 199 J	P1.2 ■ 223 J	P1.3 ■ 230 J	P2.1 ■ 170 J	P2.2 ■ 150 J	P2.3 ■ 133 I	P3.1 ■ 138 J	P3.2 ■ 111 I	P3.3 ■ 94 I	P4.1 ■ 82 I	P4.2 ■ 70 I	M1.1 ■ 115 J	M1.2 ■ 97 J	M2.1 ■ 102 J
M2.2 ■ 84 I	M3.1 ■ 94 I	M3.2 ■ 81 I	K1.1 ■ 196 J	K1.2 ■ 145 J	K1.3 ■ 109 J	K2.1 ■ 202 J	K2.2 ■ 164 J	K2.3 ■ 131 I	K3.1 ■ 178 J	K3.2 ■ 136 J	K3.3 ■ 110 I	K4.1 ■ 165 I	K4.2 ■ 125 I
K4.3 ■ 91 I	K4.4 ■ 78 I	K4.5 ■ 65 I	K5.1 ■ 187 I	K5.2 ■ 141 I	K5.3 ■ 109 I	S1.2 ■ 69 I	S2.1 ■ 53 I	S3.1 ■ 40 I	S4.1 ■ 31 I				

DCON MS tolérance h6; RE \pm 0.02 mm.

Product	DC (mm)	RE (mm)	DCON MS (mm)	APMX (mm)	OAL (mm)	NOF	LU (mm)	DN (mm)
S722HB3.0	3.00	0.10	6.00	9.00	50.0	4	15.00	2.80
S722HB4.0	4.00	0.10	6.00	11.00	57.0	4	20.00	3.70
S722HB5.0	5.00	0.10	6.00	13.00	57.0	4	20.00	4.60
S722HB6.0	6.00	0.10	6.00	20.00	60.0	4	25.00	5.50
S722HB8.0	8.00	0.20	8.00	20.00	64.0	4	26.00	7.40
S722HB10.0	10.00	0.20	10.00	27.00	70.0	4	32.00	9.20
S722HB12.0	12.00	0.20	12.00	26.00	83.0	4	37.00	11.00
S722HB14.0	14.00	0.20	14.00	26.00	83.0	4	37.00	13.00
S722HB16.0	16.00	0.20	16.00	32.00	92.0	4	42.00	15.00
S722HB18.0	18.00	0.20	18.00	32.00	92.0	4	42.00	17.00
S722HB20.0	20.00	0.20	20.00	38.00	104.0	4	50.00	19.00

S768



Fraise de finition en carbure monobloc à 4 dents, série longue

Fraise à 4 dents avec hélice variable et un pas différentiel réduisant les vibrations et améliorant l'état de surface lors du fraisage de parois profondes en fraisage de profil. Un détalonnage évite le contact de la fraise avec la paroi et augmente la portée. Le revêtement TiSiN augmente la durée de vie de l'outil et améliore les performances.

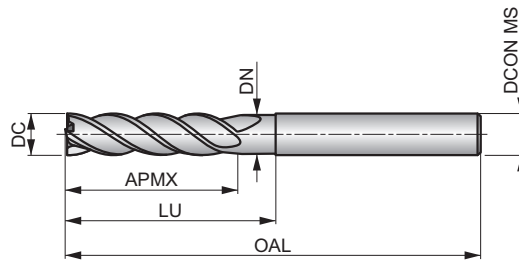

HM	N	NOF 4#
	$\lambda \neq$	γ 10°
DIN 6535HA	TiSiN	DC h9



Adéquation du groupe de matériaux de la pièce, valeurs de départ pour la vitesse de coupe (m/min) et code alpha. Tableaux d'avances par dent et facteurs de correction à partir de la page 266.

P1.1 ■ 148 l	P1.2 ■ 165 l	P1.3 ■ 170 l	P2.1 ■ 126 l	P2.2 ■ 111 l	P2.3 ■ 98 G	P3.1 ■ 102 l	P3.2 ■ 82 G	P3.3 ■ 69 G	P4.1 ■ 60 G	P4.2 ■ 52 G	M1.1 ■ 85 l	M1.2 ■ 72 l	M2.1 ■ 76 l
M2.2 ■ 62 l	M3.1 ■ 70 l	M3.2 ■ 60 l	K1.1 ■ 146 l	K1.2 ■ 108 l	K1.3 ■ 81 l	K2.1 ■ 150 l	K2.2 ■ 122 l	K2.3 ■ 97 G	K3.1 ■ 132 l	K3.2 ■ 102 l	K3.3 ■ 82 G	K4.1 ■ 123 G	K4.2 ■ 92 G
K4.3 ■ 68 G	K4.4 ■ 58 l	K4.5 ■ 48 l	K5.1 ■ 139 G	K5.2 ■ 104 G	K5.3 ■ 81 G	S1.2 ■ 50 l	S2.1 ■ 39 G	S3.1 ■ 29 G	S4.1 ■ 23 G				

DCON MS tolérance h6; RE ±0.01 mm.

Product	DC (mm)	RE (mm)	DCON MS (mm)	APMX (mm)	OAL (mm)	NOF	LU (mm)	DN (mm)
S7684.0	4.00	0.10	6.00	19.00	75.0	4	32.00	3.70
S7685.0	5.00	0.10	6.00	19.00	75.0	4	32.00	4.60
S7686.0	6.00	0.10	6.00	25.00	75.0	4	32.00	5.50
S7688.0	8.00	0.20	8.00	30.00	75.0	4	38.00	7.40
S76810.0	10.00	0.20	10.00	40.00	100.0	4	50.00	9.20
S76812.0	12.00	0.30	12.00	45.00	100.0	4	55.00	11.00
S76816.0	16.00	0.30	16.00	65.00	125.0	4	75.00	15.00
S76820.0	20.00	0.30	20.00	65.00	125.0	4	75.00	19.00

S260



Fraise de finition en carbure monobloc à 4 dents

Fraise à 4 dents avec une longueur de coupe courte offrant une grande rigidité pour le fraisage de profil standard. Le revêtement AlCrN améliore les performances et prolonge la durée de vie de l'outil lors du fraisage de matériaux difficiles à usiner. L'hélice à 40° avec un pas différentiel réduit les vibrations et maximise la productivité et la durée de vie de l'outil.

HM	N	NOF 4#
	λ 40°	γ 4°
DIN 6335HA	AlCrN	DC h9
	DORMER	

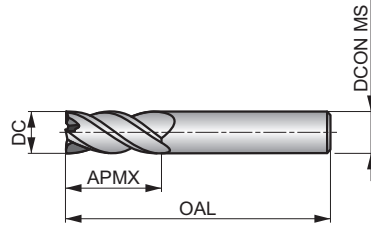

Adéquation du groupe de matériaux de la pièce, valeurs de départ pour la vitesse de coupe (m/min) et code alpha. Tableaux d'avances par dent et facteurs de correction à partir de la page 266.

P4.3 ■ 97 J	M2.3 ■ 97 J	M3.3 ■ 99 I	M4.1 ■ 97 I	M4.2 ■ 83 I	S1.3 ■ 70 I	S2.2 ■ 56 I	S3.2 ■ 40 I	S4.2 ■ 32 I	H1.1 ■ 179 I	H2.1 ■ 106 G	H3.1 ■ 118 G	H3.2 ■ 97 G
-----------------------	-----------------------	-----------------------	-----------------------	-----------------------	-----------------------	-----------------------	-----------------------	-----------------------	------------------------	------------------------	------------------------	-----------------------

DCON MS tolérance h6.

Product	DC (mm)	DCON MS (mm)	APMX (mm)	OAL (mm)	NOF
S2603.0	3.00	6.00	9.00	57.0	4
S2604.0	4.00	6.00	12.00	57.0	4
S2605.0	5.00	6.00	13.00	57.0	4
S2606.0	6.00	6.00	13.00	57.0	4
S2608.0	8.00	8.00	20.00	64.0	4
S26010.0	10.00	10.00	22.00	72.0	4
S26012.0	12.00	12.00	26.00	83.0	4
S26014.0	14.00	14.00	32.00	83.0	4
S26016.0	16.00	16.00	32.00	92.0	4
S26018.0	18.00	18.00	38.00	92.0	4
S26020.0	20.00	20.00	38.00	104.0	4

S262



Fraise torique en carbure monobloc à 4 dents

Fraise à 4 dents avec une longueur de coupe courte et différents rayons en bout disponibles offrant une grande rigidité pour le fraisage de profil standard lorsqu'un rayon d'angle est requis. Le revêtement AlCrN améliore les performances lors du fraisage de matériaux difficiles à usiner. L'hélice à 40° avec un pas différentiel réduit les vibrations et maximise la productivité.

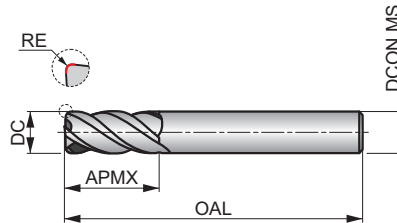

HM	N	NOF 4#
	λ 40°	γ 4°
DIN 6535HA	AlCrN	DC h9

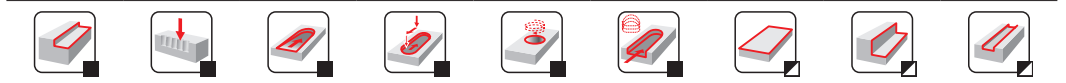

Adéquation du groupe de matériaux de la pièce, valeurs de départ pour la vitesse de coupe (m/min) et code alpha. Tableaux d'avances par dent et facteurs de correction à partir de la page 266.

P4.3 ■ 97 J	M2.3 ■ 97 J	M3.3 ■ 99 I	M4.1 ■ 97 I	M4.2 ■ 83 I	S1.3 ■ 70 I	S2.2 ■ 56 I	S3.2 ■ 40 I	S4.2 ■ 32 I	H1.1 ■ 179 I	H2.1 ■ 106 G	H3.1 ■ 118 G	H3.2 ■ 97 G
-----------------------	-----------------------	-----------------------	-----------------------	-----------------------	-----------------------	-----------------------	-----------------------	-----------------------	------------------------	------------------------	------------------------	-----------------------

DCON MS tolérance h6; RE ±0.01 mm.

Product	DC (mm)	RE (mm)	DCON MS (mm)	APMX (mm)	OAL (mm)	NOF
S2623.0XR0.3	3.00	0.30	6.00	9.00	50.0	4
S2623.0XR0.5	3.00	0.50	6.00	9.00	50.0	4
S2624.0XR0.3	4.00	0.30	6.00	12.00	57.0	4
S2624.0XR0.5	4.00	0.50	6.00	12.00	57.0	4
S2624.0XR1.0	4.00	1.00	6.00	12.00	57.0	4
S2625.0XR0.3	5.00	0.30	6.00	15.00	57.0	4
S2625.0XR0.5	5.00	0.50	6.00	15.00	57.0	4
S2626.0XR0.3	6.00	0.30	6.00	16.00	57.0	4
S2626.0XR0.5	6.00	0.50	6.00	16.00	57.0	4
S2626.0XR1.0	6.00	1.00	6.00	16.00	57.0	4
S2628.0XR0.3	8.00	0.30	8.00	20.00	64.0	4
S2628.0XR0.5	8.00	0.50	8.00	20.00	64.0	4
S2628.0XR1.0	8.00	1.00	8.00	20.00	64.0	4
S2628.0XR1.5	8.00	1.50	8.00	20.00	64.0	4
S2628.0XR2.0	8.00	2.00	8.00	20.00	64.0	4
S26210.0XR0.3	10.00	0.30	10.00	22.00	72.0	4
S26210.0XR0.5	10.00	0.50	10.00	22.00	72.0	4
S26210.0XR1.0	10.00	1.00	10.00	22.00	72.0	4
S26210.0XR1.5	10.00	1.50	10.00	22.00	72.0	4
S26210.0XR2.0	10.00	2.00	10.00	22.00	72.0	4
S26212.0XR0.3	12.00	0.30	12.00	26.00	83.0	4
S26212.0XR0.5	12.00	0.50	12.00	26.00	83.0	4
S26212.0XR1.0	12.00	1.00	12.00	26.00	83.0	4
S26212.0XR2.0	12.00	2.00	12.00	26.00	83.0	4
S26212.0XR2.5	12.00	2.50	12.00	26.00	83.0	4
S26212.0XR3.0	12.00	3.00	12.00	26.00	83.0	4
S26214.0XR0.3	14.00	0.30	14.00	32.00	83.0	4
S26214.0XR0.5	14.00	0.50	14.00	32.00	83.0	4
S26214.0XR1.0	14.00	1.00	14.00	32.00	83.0	4
S26214.0XR2.0	14.00	2.00	14.00	32.00	83.0	4
S26214.0XR3.0	14.00	3.00	14.00	32.00	83.0	4

Product	DC	RE	DCON MS	APMX	OAL	NOF
	(mm)	(mm)	(mm)	(mm)	(mm)	
S26216.0XR0.3	16.00	0.30	16.00	32.00	92.0	4
S26216.0XR0.5	16.00	0.50	16.00	32.00	92.0	4
S26216.0XR1.0	16.00	1.00	16.00	32.00	92.0	4
S26216.0XR2.0	16.00	2.00	16.00	32.00	92.0	4
S26216.0XR2.5	16.00	2.50	16.00	32.00	92.0	4
S26216.0XR3.0	16.00	3.00	16.00	32.00	92.0	4
S26216.0XR4.0	16.00	4.00	16.00	32.00	92.0	4
S26218.0XR0.3	18.00	0.30	18.00	38.00	92.0	4
S26218.0XR0.5	18.00	0.50	18.00	38.00	92.0	4
S26218.0XR1.0	18.00	1.00	18.00	38.00	92.0	4
S26218.0XR2.0	18.00	2.00	18.00	38.00	92.0	4
S26218.0XR3.0	18.00	3.00	18.00	38.00	92.0	4
S26220.0XR0.3	20.00	0.30	20.00	38.00	104.0	4
S26220.0XR0.5	20.00	0.50	20.00	38.00	104.0	4
S26220.0XR1.0	20.00	1.00	20.00	38.00	104.0	4
S26220.0XR2.0	20.00	2.00	20.00	38.00	104.0	4
S26220.0XR2.5	20.00	2.50	20.00	38.00	104.0	4
S26220.0XR3.0	20.00	3.00	20.00	38.00	104.0	4
S26220.0XR4.0	20.00	4.00	20.00	38.00	104.0	4

S219



Fraise de finition en carbure monobloc à 4 dents, longue portée

Fraise à 4 dents avec une longueur de coupe extra courte offrant une grande rigidité pour le fraisage des zones difficiles à atteindre. Le détalonnage évite le contact de la fraise avec la paroi. Le revêtement AlTiN augmente la durée de vie de l'outil et améliore les performances lors du fraisage de matériaux difficiles à usiner. L'hélice à 40° est conçue pour un usinage de haute performance.

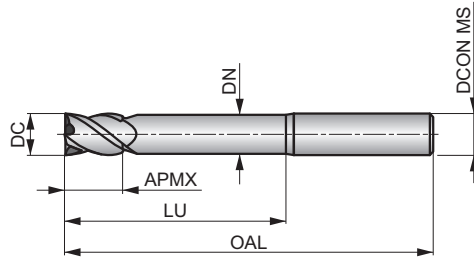

HM	N	NOF 4
	40°	3°
DIN 6335HA	AlTiN	DC h9



Adéquation du groupe de matériaux de la pièce, valeurs de départ pour la vitesse de coupe (m/min) et code alpha. Tableaux d'avances par dent et facteurs de correction à partir de la page 266.

P4.3	M2.3	M3.3	M4.1	M4.2	S1.3	S2.2	S3.2	S4.2
■ 64 J	■ 64 J	■ 65 I	■ 64 I	■ 54 I	■ 46 I	■ 38 I	■ 26 I	■ 22 I

DCON MS tolérance h6.

Product	DC (mm)	DCON MS (mm)	APMX (mm)	OAL (mm)	NOF	LU (mm)	DN (mm)
S2193.0	3.00	3.00	5.00	60.0	4	30.00	2.80
S2194.0	4.00	4.00	8.00	60.0	4	32.00	3.70
S2195.0	5.00	5.00	9.00	60.0	4	32.00	4.60
S2196.0	6.00	6.00	10.00	75.0	4	40.00	5.50
S2198.0	8.00	8.00	12.00	75.0	4	40.00	7.40
S21910.0	10.00	10.00	14.00	75.0	4	40.00	9.20
S21912.0	12.00	12.00	16.00	100.0	4	60.00	11.00
S21914.0	14.00	14.00	22.00	125.0	4	85.00	13.00
S21916.0	16.00	16.00	22.00	125.0	4	85.00	15.00
S21918.0	18.00	18.00	26.00	125.0	4	85.00	17.00
S21920.0	20.00	20.00	26.00	125.0	4	85.00	19.00

S612

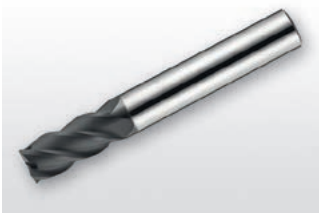

Fraise de finition en carbure monobloc à 4 dents

Fraise à 4 dents avec une longueur de coupe courte offrant une grande rigidité pour le fraisage de profil standard. Le revêtement de type diamant augmente la durée de vie et améliore les performances. Pour le fraisage de matériaux abrasifs.

HM	N	NOF 4
	λ 40°	γ 10°
DIN 6335HA	Diamond	DC h9
	DORMER	

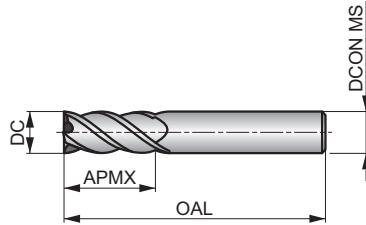

Adéquation du groupe de matériaux de la pièce, valeurs de départ pour la vitesse de coupe (m/min) et code alpha. Tableaux d'avances par dent et facteurs de correction à partir de la page 266.

N5.1

■ 350 G

DCON MS tolérance h6.

Product	DC (mm)	DCON MS (mm)	APMX (mm)	OAL (mm)	NOF
S6121.0	1.00	3.00	3.00	50.0	4
S6121.5	1.50	3.00	4.50	50.0	4
S6122.0	2.00	3.00	6.50	50.0	4
S6122.5	2.50	3.00	6.50	50.0	4
S6123.0	3.00	3.00	9.00	50.0	4
S6124.0	4.00	4.00	12.00	50.0	4
S6125.0	5.00	5.00	15.00	50.0	4
S6126.0	6.00	6.00	20.00	60.0	4
S6128.0	8.00	8.00	20.00	64.0	4
S61210.0	10.00	10.00	22.00	70.0	4
S61212.0	12.00	12.00	25.00	75.0	4

S662



Fraise torique en carbure monobloc à 4 dents

Fraise à 4 dents avec un pas différentiel, une longueur de coupe courte et différents rayons d'angle disponibles recommandée pour le fraisage de profil où un rayon d'angle est requis. La S662, avec une géométrie à arêtes vives est conçue pour un usinage de haute performance dans les matériaux non-ferreux.

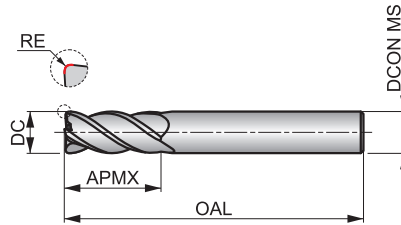

HM	W	NOF 4#
	λ 40°	γ 10°
DIN 6535HA	Bright	DC h9
	DORMER	

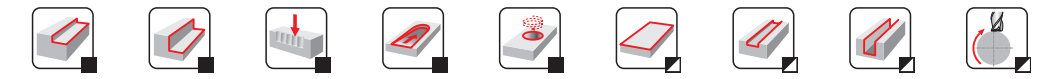

Adéquation du groupe de matériaux de la pièce, valeurs de départ pour la vitesse de coupe (m/min) et code alpha. Tableaux d'avances par dent et facteurs de correction à partir de la page 266.

N1.1 ■ 709 0	N1.2 ■ 533 0	N1.3 ■ 357 0	N2.1 ■ 357 N	N2.2 ■ 320 N	N2.3 ■ 229 N	N3.1 ■ 373 N	N3.2 ■ 219 N	N3.3 ■ 112 N	N4.1 ■ 373 P	N4.2 ■ 144 P
------------------------	------------------------	------------------------	------------------------	------------------------	------------------------	------------------------	------------------------	------------------------	------------------------	------------------------

DCON MS tolérance h6; RE ±0.01 mm.

Product	DC (mm)	RE (mm)	DCON MS (mm)	APMX (mm)	OAL (mm)	NOF
S6623.0XR0.3	3.00	0.30	6.00	9.00	57.0	4
S6624.0XR0.3	4.00	0.30	6.00	12.00	57.0	4
S6624.0XR0.5	4.00	0.50	6.00	12.00	57.0	4
S6625.0XR0.3	5.00	0.30	6.00	15.00	57.0	4
S6625.0XR0.5	5.00	0.50	6.00	15.00	57.0	4
S6626.0XR0.5	6.00	0.50	6.00	16.00	57.0	4
S6626.0XR1.0	6.00	1.00	6.00	16.00	57.0	4
S6626.0XR2.0	6.00	2.00	6.00	16.00	57.0	4
S6628.0XR0.5	8.00	0.50	8.00	20.00	64.0	4
S6628.0XR1.0	8.00	1.00	8.00	20.00	64.0	4
S6628.0XR2.0	8.00	2.00	8.00	20.00	64.0	4
S66210.0XR0.5	10.00	0.50	10.00	22.00	72.0	4
S66210.0XR1.0	10.00	1.00	10.00	22.00	72.0	4
S66210.0XR2.0	10.00	2.00	10.00	22.00	72.0	4
S66212.0XR1.0	12.00	1.00	12.00	26.00	83.0	4
S66212.0XR2.0	12.00	2.00	12.00	26.00	83.0	4
S66212.0XR2.5	12.00	2.50	12.00	26.00	83.0	4
S66212.0XR3.0	12.00	3.00	12.00	26.00	83.0	4
S66216.0XR1.0	16.00	1.00	16.00	32.00	92.0	4
S66216.0XR2.0	16.00	2.00	16.00	32.00	92.0	4
S66216.0XR3.0	16.00	3.00	16.00	32.00	92.0	4
S66216.0XR4.0	16.00	4.00	16.00	32.00	92.0	4
S66220.0XR2.0	20.00	2.00	20.00	38.00	104.0	4
S66220.0XR4.0	20.00	4.00	20.00	38.00	104.0	4

S521



Fraise torique en carbure monobloc à 4 dents

Fraise à 4 dents avec hélice à 45°, une longueur de coupe extra courte ainsi que des rayons d'angle différents offrant une grande rigidité pour le fraisage de contours lorsqu'un rayon d'angle est requis. Le revêtement TiSiN améliore les performances et l'hélice à 45° est conçue pour un usinage de haute performance dans les matériaux trempés jusqu'à 63 HRC.

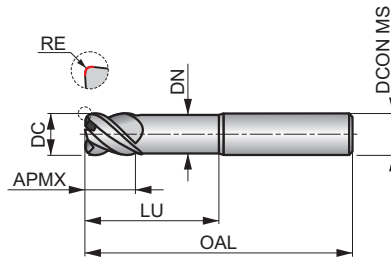

HM	N	NOF 4
	45°	γ -10°
DIN 6335HA	TiSiN	DC h9

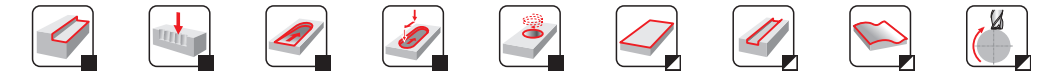

Adéquation du groupe de matériaux de la pièce, valeurs de départ pour la vitesse de coupe (m/min) et code alpha. Tableaux d'avances par dent et facteurs de correction à partir de la page 266.

H1.1 ■ 119 I	H2.1 ■ 70 G	H2.2 ■ 60 E	H3.1 ■ 78 G	H3.2 ■ 64 G	H4.1 ■ 50 E	H4.2 ■ 42 B
------------------------	-----------------------	-----------------------	-----------------------	-----------------------	-----------------------	-----------------------

DCON MS tolérance h6; RE ±0.01 mm.

Product	DC (mm)	RE (mm)	DCON MS (mm)	APMX (mm)	OAL (mm)	NOF	LU (mm)	DN (mm)
S5213.0XR0.3	3.00	0.30	6.00	4.00	60.0	4	14.00	2.80
S5214.0XR0.3	4.00	0.30	6.00	5.00	60.0	4	16.00	3.70
S5214.0XR0.5	4.00	0.50	6.00	5.00	60.0	4	16.00	3.70
S5215.0XR0.3	5.00	0.30	6.00	6.00	60.0	4	18.00	4.60
S5215.0XR0.5	5.00	0.50	6.00	6.00	60.0	4	18.00	4.60
S5216.0XR0.5	6.00	0.50	6.00	7.00	60.0	4	20.00	5.50
S5216.0XR1.0	6.00	1.00	6.00	7.00	60.0	4	20.00	5.50
S5218.0XR0.5	8.00	0.50	8.00	9.00	64.0	4	26.00	7.40
S5218.0XR1.0	8.00	1.00	8.00	9.00	64.0	4	26.00	7.40
S52110.0XR1.0	10.00	1.00	10.00	11.00	70.0	4	31.00	9.20
S52110.0XR2.0	10.00	2.00	10.00	11.00	70.0	4	31.00	9.20
S52112.0XR1.0	12.00	1.00	12.00	13.00	75.0	4	37.00	11.00
S52112.0XR2.0	12.00	2.00	12.00	13.00	75.0	4	37.00	11.00
S52116.0XR1.0	16.00	1.00	16.00	17.00	90.0	4	43.00	15.00
S52116.0XR2.0	16.00	2.00	16.00	17.00	90.0	4	43.00	15.00
S52116.0XR3.0	16.00	3.00	16.00	17.00	90.0	4	43.00	15.00

S523



Fraise torique en carbure monobloc à 4 dents

Fraise à 4 dents avec une longueur de coupe courte et différents rayons en bout disponibles offrant une grande rigidité pour le fraisage de profil standard lorsqu'un rayon d'angle est requis. Le revêtement TiSiN améliore les performances et l'hélice à 40° est conçue pour un usinage de haute performance dans les matériaux trempés jusqu'à 63 HRC.

HM	N	NOF 4
	λ 40°	γ -6°
DIN 6535HA	TiSiN	DC h9

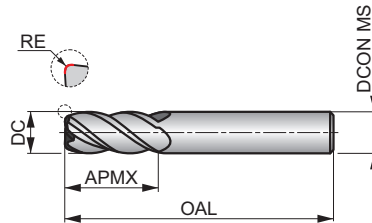

Adéquation du groupe de matériaux de la pièce, valeurs de départ pour la vitesse de coupe (m/min) et code alpha. Tableaux d'avances par dent et facteurs de correction à partir de la page 266.

H1.1	H2.1	H2.2	H3.1	H3.2	H4.1	H4.2
■ 119 I	■ 70 G	■ 60 E	■ 78 G	■ 64 G	■ 50 E	■ 42 B

DCON MS tolérance h6; RE ±0.01 mm.

Product	DC (mm)	RE (mm)	DCON MS (mm)	APMX (mm)	OAL (mm)	NOF
S5231.5XR0.2	1.50	0.20	6.00	4.50	50.0	4
S5232.0XR0.2	2.00	0.20	6.00	6.50	50.0	4
S5233.0XR0.2XD3	3.00	0.20	3.00	9.00	50.0	4
S5233.0XR0.3XD3	3.00	0.30	3.00	9.00	50.0	4
S5233.0XR0.2XD6	3.00	0.20	6.00	9.00	50.0	4
S5233.0XR0.3XD6	3.00	0.30	6.00	9.00	50.0	4
S5233.0XR0.5XD6	3.00	0.50	6.00	9.00	50.0	4
S5234.0XR0.3XD4	4.00	0.30	4.00	12.00	50.0	4
S5234.0XR0.5XD4	4.00	0.50	4.00	12.00	50.0	4
S5234.0XR0.3XD6	4.00	0.30	6.00	12.00	50.0	4
S5234.0XR0.5XD6	4.00	0.50	6.00	12.00	50.0	4
S5235.0XR0.3XD5	5.00	0.30	5.00	15.00	50.0	4
S5235.0XR0.5XD5	5.00	0.50	5.00	15.00	50.0	4
S5235.0XR0.3XD6	5.00	0.30	6.00	15.00	50.0	4
S5235.0XR0.5XD6	5.00	0.50	6.00	15.00	50.0	4
S5236.0XR0.3	6.00	0.30	6.00	16.00	50.0	4
S5236.0XR0.5	6.00	0.50	6.00	16.00	50.0	4
S5236.0XR1.0	6.00	1.00	6.00	16.00	50.0	4
S5238.0XR0.3	8.00	0.30	8.00	20.00	64.0	4
S5238.0XR0.5	8.00	0.50	8.00	20.00	64.0	4
S5238.0XR1.0	8.00	1.00	8.00	20.00	64.0	4
S5238.0XR2.0	8.00	2.00	8.00	20.00	64.0	4
S52310.0XR0.5	10.00	0.50	10.00	22.00	70.0	4
S52310.0XR1.0	10.00	1.00	10.00	22.00	70.0	4
S52310.0XR1.5	10.00	1.50	10.00	22.00	70.0	4
S52310.0XR2.0	10.00	2.00	10.00	22.00	70.0	4
S52312.0XR0.5	12.00	0.50	12.00	25.00	75.0	4
S52312.0XR1.0	12.00	1.00	12.00	25.00	75.0	4
S52312.0XR2.0	12.00	2.00	12.00	25.00	75.0	4
S52312.0XR3.0	12.00	3.00	12.00	25.00	75.0	4
S52316.0XR0.5	16.00	0.50	16.00	32.00	90.0	4



Product	DC	RE	DCON MS	APMX	OAL	NOF
	(mm)	(mm)	(mm)	(mm)	(mm)	
S52316.0XR1.0	16.00	1.00	16.00	32.00	90.0	4
S52316.0XR2.0	16.00	2.00	16.00	32.00	90.0	4
S52316.0XR3.0	16.00	3.00	16.00	32.00	90.0	4

S524

DORMER



Fraise torique en carbure monobloc à 4 dents, longue portée

Fraise à 4 dents avec hélice à 40°, une longueur de coupe extra courte ainsi que des rayons d'angle différents offrant une grande rigidité pour le fraisage de profil dans les zones difficiles d'accès où un rayon est nécessaire. Détalonnage de la queue pour éviter le contact de la fraise avec la paroi. Le revêtement TiSiN améliore les performances d'usinage dans les matériaux trempés jusqu'à 63 HRC.

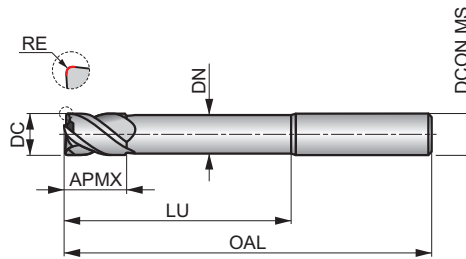

HM	N	NOF 4
	λ 40°	γ -6°
DIN 6335HA	TiSiN	DC h9

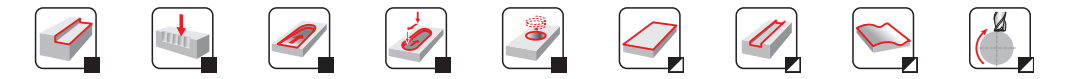

Adéquation du groupe de matériaux de la pièce, valeurs de départ pour la vitesse de coupe (m/min) et code alpha. Tableaux d'avances par dent et facteurs de correction à partir de la page 266.

H1.1 ■ 119 I	H2.1 ■ 70 G	H2.2 ■ 60 E	H3.1 ■ 78 G	H3.2 ■ 64 G	H4.1 ■ 50 E	H4.2 ■ 42 B
------------------------	-----------------------	-----------------------	-----------------------	-----------------------	-----------------------	-----------------------

DCON MS tolérance h6; RE ±0.01 mm.

Product	DC (mm)	RE (mm)	DCON MS (mm)	APMX (mm)	OAL (mm)	NOF	LU (mm)	DN (mm)
S5243.0XR0.3	3.00	0.30	6.00	5.00	75.0	4	30.00	2.80
S5244.0XR0.3	4.00	0.30	6.00	8.00	75.0	4	32.00	3.70
S5244.0XR0.5	4.00	0.50	6.00	8.00	75.0	4	32.00	3.70
S5245.0XR0.3	5.00	0.30	6.00	9.00	75.0	4	32.00	4.60
S5245.0XR0.5	5.00	0.50	6.00	9.00	75.0	4	32.00	4.60
S5246.0XR0.3	6.00	0.30	6.00	10.00	75.0	4	40.00	5.50
S5246.0XR0.5	6.00	0.50	6.00	10.00	75.0	4	40.00	5.50
S5246.0XR1.0	6.00	1.00	6.00	10.00	75.0	4	40.00	5.50
S5248.0XR0.3	8.00	0.30	8.00	12.00	75.0	4	40.00	7.40
S5248.0XR0.5	8.00	0.50	8.00	12.00	75.0	4	40.00	7.40
S5248.0XR1.0	8.00	1.00	8.00	12.00	75.0	4	40.00	7.40
S52410.0XR0.5	10.00	0.50	10.00	14.00	75.0	4	40.00	9.20
S52410.0XR1.0	10.00	1.00	10.00	14.00	75.0	4	40.00	9.20
S52410.0XR2.0	10.00	2.00	10.00	14.00	75.0	4	40.00	9.20
S52412.0XR0.5	12.00	0.50	12.00	16.00	100.0	4	60.00	11.00
S52412.0XR1.0	12.00	1.00	12.00	16.00	100.0	4	60.00	11.00
S52412.0XR2.0	12.00	2.00	12.00	16.00	100.0	4	60.00	11.00
S52416.0XR0.5	16.00	0.50	16.00	22.00	125.0	4	85.00	15.00
S52416.0XR1.0	16.00	1.00	16.00	22.00	125.0	4	85.00	15.00
S52416.0XR2.0	16.00	2.00	16.00	22.00	125.0	4	85.00	15.00
S52416.0XR3.0	16.00	3.00	16.00	22.00	125.0	4	85.00	15.00

S561

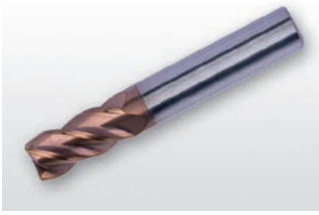

Fraise de finition en carbure monobloc à 4 dents

Fraise à 4 dents avec hélice à 40°, une longueur de coupe moyenne et un angle de coupe négatif permettant le fraisage de matériaux durs jusqu'à 70 HRC. Le revêtement TiSiN améliore les performances et le pas différentiel réduit les vibrations, maximisant la productivité et la durée de vie de l'outil. Extrémités des arêtes de coupe préparées pour produire des angles vifs.

HM	N	NOF 4#
	λ 40°	γ -6°
DIN 6535HA	TiSiN	DC h9
	DORMER	

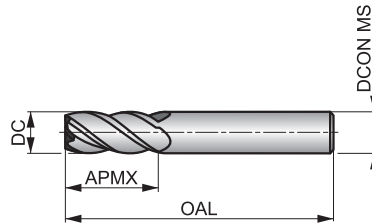

Adéquation du groupe de matériaux de la pièce, valeurs de départ pour la vitesse de coupe (m/min) et code alpha. Tableaux d'avances par dent et facteurs de correction à partir de la page 266.

H1.1	H2.1	H2.2	H3.1	H3.2	H4.1	H4.2
■ 119 I	■ 70 G	■ 60 E	■ 78 G	■ 64 G	■ 50 E	■ 42 B

DCON MS tolérance h6.

Product	DC (mm)	DCON MS (mm)	APMX (mm)	OAL (mm)	NOF
S5611.0	1.00	6.00	3.00	50.0	4
S5611.5	1.50	6.00	4.50	50.0	4
S5612.0	2.00	6.00	6.50	50.0	4
S5612.5	2.50	6.00	6.50	50.0	4
S5613.0	3.00	6.00	9.00	50.0	4
S5614.0	4.00	6.00	12.00	50.0	4
S5615.0	5.00	6.00	15.00	50.0	4
S5616.0	6.00	6.00	20.00	60.0	4
S5618.0	8.00	8.00	20.00	64.0	4
S56110.0	10.00	10.00	22.00	70.0	4
S56112.0	12.00	12.00	25.00	75.0	4
S56114.0	14.00	14.00	32.00	90.0	4
S56116.0	16.00	16.00	32.00	90.0	4
S56118.0	18.00	18.00	38.00	100.0	4
S56120.0	20.00	20.00	38.00	100.0	4

Code de matériau du corps (BMC)	HM	HM	HM	HM	HM	HM									
Profil de fraise	N	N	N	N	N	N									
Nombre de goujures (NOF)															
Longueur de coupe															
Angle d'hélice de goujure (FHA)	λ 50°	λ 50°	λ 50°	λ 50°	λ 50°	λ 50°									
Angle d'hélice de goujure (FHA)	λ 50°	λ 50°	λ 50°	λ 50°	λ 50°	λ 50°									
Angle de coupe radial (GAMF)	γ 3°	γ 3°	γ 3°	γ -26°	γ -26°	γ -26°									
Queue															
Revêtement															
Classe de tolérance du diamètre de coupe (TCDC)	DC h9	DC h9	DC h9	DC h9	DC h9	DC h9									
Direction de coupe															
Groupe standard de base (BSG)															

Code de famille de produits		S225	S226	S227	S525	S526	S527								
Plage de diamètres de coupe PSF		3.00 – 20.00	3.00 – 20.00	6.00 – 20.00	3.00 – 20.00	3.00 – 20.00	3.00 – 20.00								
P	P1														
	P2														
	P3														
	P4														
M	M1														
	M2														
	M3														
	M4														
K	K1														
	K2														
	K3														
	K4														
	K5														
N	N1														
	N2														
	N3														
	N4														
	N5														
S	S1														
	S2														
	S3														
	S4														
H	H1														
	H2														
	H3														
	H4														

S225

DORMER



Fraise de super finition en carbure monobloc à 6, 8 dents

Fraise à 6 ou 8 dents avec une longueur de coupe courte offrant une grande rigidité pour la finition des parois plus profondes. Le détalonnage de la queue évite le contact de la fraise avec la paroi et augmente la portée. Le revêtement AlTiN augmente la durée de vie et améliore les performances lors du fraisage de matériaux difficiles à usiner. L'hélice à 50° est conçue pour une qualité de finition de surface élevée.

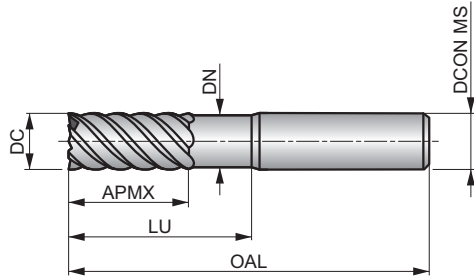

HM	N	NOF 6-8
	λ 50°	γ 3°
DIN 6535HA	AlTiN	DC h9
	DORMER	



Adéquation du groupe de matériaux de la pièce, valeurs de départ pour la vitesse de coupe (m/min) et code alpha. Tableaux d'avances par dent et facteurs de correction à partir de la page 266.

P4.3	M2.3	M3.3	M4.1	M4.2	S1.3	S2.2	S3.2	S4.2
■ 80 G	■ 80 G	■ 82 F	■ 80 F	■ 68 F	■ 58 F	■ 47 F	■ 33 F	■ 27 F

DCON MS tolérance h6.

Product	DC (mm)	DCON MS (mm)	APMX (mm)	OAL (mm)	NOF	LU (mm)	DN (mm)
S2253.0	3.00	6.00	8.00	50.0	6	20.00	2.80
S2254.0	4.00	6.00	11.00	50.0	6	20.00	3.70
S2256.0	6.00	6.00	15.00	50.0	6	20.00	5.50
S2258.0	8.00	8.00	20.00	64.0	6	30.00	7.40
S22510.0	10.00	10.00	22.00	70.0	6	32.00	9.20
S22512.0	12.00	12.00	25.00	75.0	6	37.00	11.00
S22514.0	14.00	14.00	30.00	90.0	6	44.00	13.00
S22516.0	16.00	16.00	30.00	90.0	8	46.00	15.00
S22518.0	18.00	18.00	35.00	100.0	8	53.00	17.00
S22520.0	20.00	20.00	38.00	100.0	8	58.00	19.00

S226



Fraise de super finition en carbure monobloc à 6, 8 dents, série longue

Fraise à 6 ou 8 dents avec une grande longueur de coupe offrant une grande rigidité pour la finition des parois plus profondes. Le détalonnage de la queue évite le contact de la fraise avec la paroi et augmente la portée. Le revêtement AITiN augmente la durée de vie et améliore les performances lors du fraisage de matériaux difficiles à usiner. L'hélice à 50° est conçue pour une qualité de finition de surface élevée.

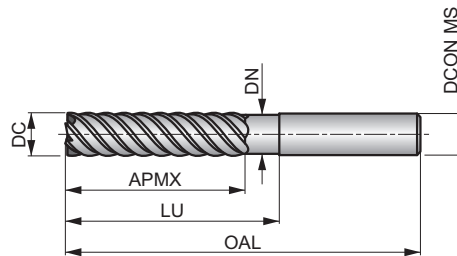

HM	N	NOF 6-8
	λ 50°	γ 3°
DIN 6535HA	AITiN	DC h9



Adéquation du groupe de matériaux de la pièce, valeurs de départ pour la vitesse de coupe (m/min) et code alpha. Tableaux d'avances par dent et facteurs de correction à partir de la page 266.

P4.3	M2.3	M3.3	M4.1	M4.2	S1.3	S2.2	S3.2	S4.2
■ 64 G	■ 64 G	■ 65 F	■ 64 F	■ 54 F	■ 46 F	■ 38 F	■ 26 F	■ 22 F

DCON MS tolérance h6.

Product	DC (mm)	DCON MS (mm)	APMX (mm)	OAL (mm)	NOF	LU (mm)	DN (mm)
S2263.0	3.00	6.00	19.00	75.0	6	30.00	2.80
S2264.0	4.00	6.00	19.00	75.0	6	32.00	3.70
S2266.0	6.00	6.00	31.00	75.0	6	40.00	5.50
S2268.0	8.00	8.00	31.00	75.0	6	40.00	7.40
S22610.0	10.00	10.00	45.00	100.0	6	60.00	9.20
S22612.0	12.00	12.00	50.00	100.0	6	60.00	11.00
S22614.0	14.00	14.00	57.00	125.0	6	85.00	13.00
S22616.0	16.00	16.00	57.00	125.0	8	85.00	15.00
S22618.0	18.00	18.00	57.00	125.0	8	85.00	17.00
S22620.0	20.00	20.00	57.00	125.0	8	85.00	19.00

S227

DORMER



Fraise de super finition en carbure monobloc à 6, 8 dents, série extra longue

Fraise à 6 ou 8 dents avec une longueur de coupe extra longue offrant une grande rigidité pour la finition des parois très profondes. Le détalonnage évite le contact de la fraise avec la paroi et augmente la portée. Le revêtement AlTiN augmente la durée de vie de l'outil et améliore les performances lors du fraisage de matériaux difficiles à usiner. L'hélice à 50° est conçue pour une qualité de finition de surface élevée.

HM	N	NOF 6-8
	λ 50°	γ 3°
DIN 6535HA	AlTiN	DC h9
	DORMER	

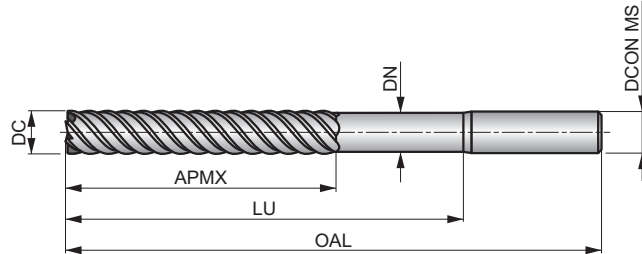

Adéquation du groupe de matériaux de la pièce, valeurs de départ pour la vitesse de coupe (m/min) et code alpha. Tableaux d'avances par dent et facteurs de correction à partir de la page 266.

P4.3	M2.3	M3.3	M4.1	M4.2	S1.3	S2.2	S3.2	S4.2
■ 40 G	■ 40 G	■ 41 F	■ 40 F	■ 34 F	■ 29 F	■ 24 F	■ 17 F	■ 14 F

DCON MS tolérance h6.

Product	DC (mm)	DCON MS (mm)	APMX (mm)	OAL (mm)	NOF	LU (mm)	DN (mm)
S2276.0	6.00	6.00	38.00	100.0	6	60.00	5.50
S2278.0	8.00	8.00	41.00	100.0	6	60.00	7.40
S22710.0	10.00	10.00	57.00	125.0	6	85.00	9.20
S22712.0	12.00	12.00	75.00	150.0	6	110.00	11.00
S22714.0	14.00	14.00	75.00	150.0	6	110.00	13.00
S22716.0	16.00	16.00	75.00	150.0	8	110.00	15.00
S22718.0	18.00	18.00	75.00	150.0	8	110.00	17.00
S22720.0	20.00	20.00	75.00	150.0	8	110.00	19.00

S525



Fraise de super finition en carbure monobloc à 6, 8 dents

Fraise à 6 ou 8 dents avec hélice à 50° et une longueur de coupe courte offrant une grande rigidité pour la finition des parois plus profondes. Le détalonnage de la queue évite le contact de la fraise avec la paroi et augmente la portée. Le revêtement TiSiN augmente la durée de vie de l'outil et améliore les performances lors du fraisage de matériaux trempés jusqu'à 63 HRC.

HM	N	NOF 6-8
	λ 50°	γ -26°
DIN 6335HA	TiSiN	DC h9
	DORMER	

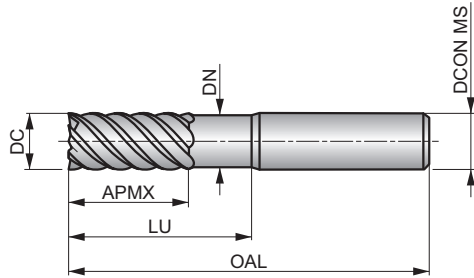

Adéquation du groupe de matériaux de la pièce, valeurs de départ pour la vitesse de coupe (m/min) et code alpha. Tableaux d'avances par dent et facteurs de correction à partir de la page 266.

H1.1	H2.1	H2.2	H3.1	H3.2	H4.1	H4.2
■ 119 G	■ 70 G	■ 60 E	■ 78 G	■ 64 G	■ 50 E	■ 42 A

DCON MS tolérance h6.

Product	DC (mm)	DCON MS (mm)	APMX (mm)	OAL (mm)	NOF	LU (mm)	DN (mm)
S5253.0	3.00	6.00	8.00	50.0	6	20.00	2.80
S5254.0	4.00	6.00	11.00	50.0	6	20.00	3.70
S5256.0	6.00	6.00	15.00	50.0	6	20.00	5.50
S5258.0	8.00	8.00	20.00	64.0	6	30.00	7.40
S52510.0	10.00	10.00	22.00	70.0	6	32.00	9.20
S52512.0	12.00	12.00	25.00	75.0	6	37.00	11.00
S52514.0	14.00	14.00	30.00	90.0	6	44.00	13.00
S52516.0	16.00	16.00	30.00	90.0	8	46.00	15.00
S52518.0	18.00	18.00	35.00	100.0	8	53.00	17.00
S52520.0	20.00	20.00	38.00	100.0	8	58.00	19.00

S526



Fraise de super finition en carbure monobloc à 6, 8 dents, série longue

Fraise à 6 ou 8 dents avec hélice à 50° et une grande longueur de coupe offrant une grande rigidité pour la finition des parois plus profondes. Le détalonnage de la queue évite le contact de la fraise avec la paroi et augmente la portée. Le revêtement TiSiN augmente la durée de vie de l'outil et améliore les performances lors du fraisage de matériaux trempés jusqu'à 63 HRC.

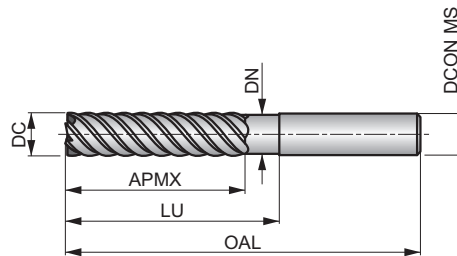

HM	N	NOF 6-8
	λ 50°	γ -26°
DIN 6535HA	TiSiN	DC h9



Adéquation du groupe de matériaux de la pièce, valeurs de départ pour la vitesse de coupe (m/min) et code alpha. Tableaux d'avances par dent et facteurs de correction à partir de la page 266.

H1.1	H2.1	H2.2	H3.1	H3.2	H4.1	H4.2
■ 96 G	■ 57 G	■ 49 E	■ 63 G	■ 52 G	■ 40 E	■ 34 A

DCON MS tolérance h6.

Product	DC (mm)	DCON MS (mm)	APMX (mm)	OAL (mm)	NOF	LU (mm)	DN (mm)
S5263.0	3.00	6.00	19.00	75.0	6	30.00	2.80
S5264.0	4.00	6.00	19.00	75.0	6	32.00	3.70
S5266.0	6.00	6.00	31.00	75.0	6	40.00	5.50
S5268.0	8.00	8.00	31.00	75.0	6	40.00	7.40
S52610.0	10.00	10.00	45.00	100.0	6	60.00	9.20
S52612.0	12.00	12.00	50.00	100.0	6	60.00	11.00
S52614.0	14.00	14.00	57.00	125.0	6	85.00	13.00
S52616.0	16.00	16.00	57.00	125.0	8	85.00	15.00
S52618.0	18.00	18.00	57.00	125.0	8	85.00	17.00
S52620.0	20.00	20.00	57.00	125.0	8	85.00	19.00

S527



Fraise de super finition en carbure monobloc à 6, 8 dents, série extra longue

Fraise à 6 ou 8 dents avec hélice à 50° et une longueur de coupe extra longue offrant une grande rigidité pour la finition des parois très profondes. Le détalonnage de la queue évite le contact de la fraise avec la paroi et augmente la portée. Le revêtement TiSiN augmente la durée de vie et améliore les performances lors du fraisage de matériaux trempés jusqu'à 63 HRC.

HM	N	NOF 6-8
	λ 50°	γ -26°
DIN 6535HA	TiSiN	DC h9
	DORMER	

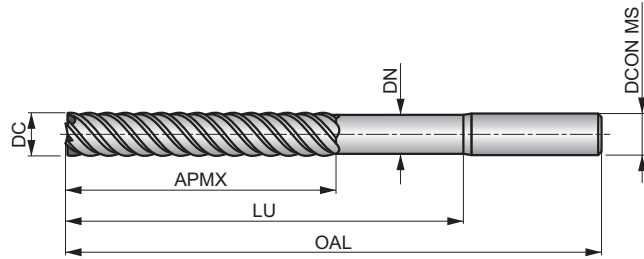

Adéquation du groupe de matériaux de la pièce, valeurs de départ pour la vitesse de coupe (m/min) et code alpha. Tableaux d'avances par dent et facteurs de correction à partir de la page 266.

H1.1 ■ 59 G	H2.1 ■ 35 G	H2.2 ■ 30 E	H3.1 ■ 39 G	H3.2 ■ 32 G	H4.1 ■ 25 E	H4.2 ■ 21 A
-----------------------	-----------------------	-----------------------	-----------------------	-----------------------	-----------------------	-----------------------

DCON MS tolérance h6.

Product	DC (mm)	DCON MS (mm)	APMX (mm)	OAL (mm)	NOF	LU (mm)	DN (mm)
S5273.0	3.00	6.00	25.00	100.0	6	60.00	2.80
S5274.0	4.00	6.00	31.00	100.0	6	60.00	3.70
S5276.0	6.00	6.00	38.00	100.0	6	60.00	5.50
S5278.0	8.00	8.00	41.00	100.0	6	60.00	7.40
S52710.0	10.00	10.00	57.00	125.0	6	85.00	9.20
S52712.0	12.00	12.00	75.00	150.0	6	110.00	11.00
S52716.0	16.00	16.00	75.00	150.0	8	110.00	15.00
S52720.0	20.00	20.00	75.00	150.0	8	110.00	19.00

Code de matériau du corps (BMC)	HM	HM	HM	HM	HM	HM	HM	HM	HM	HM	HM	HM
Profil de fraise	N	N	N	N	N	W	N	N	N	N	N	N
Nombre de goujures (NOF)	NOF 2	NOF 4	NOF 2	NOF 2	NOF 2	NOF 2	NOF 2	NOF 2	NOF 2	NOF 4	NOF 4	NOF 3-4
Longueur de coupe												
Angle d'hélice de goujure (FHA)	λ 30°	λ 30°	λ 30°	λ 30°	λ 30°	λ 30°	λ 30°	λ 30°	λ 30°	λ 30°	λ 30°	λ 30°
Angle d'hélice de goujure (FHA)	λ 30°	λ 30°	λ 30°	λ 30°	λ 30°	λ 30°	λ 30°	λ 30°	λ 30°	λ 30°	λ 30°	λ 30°
Angle de coupe radial (GAMF)	γ 10°	γ 10°	γ 3°	γ 3°	γ 3°	γ 15°	γ -10°	γ -10°	γ -10°	γ -10°	γ -10°	γ 8°
Queue												
Revêtement	X-CEED	X-CEED	TISIN	TISIN	TISIN	Bright	TISIN	TISIN	TISIN	TISIN	TISIN	AlCN
Classe de tolérance du diamètre de coupe (TCDC)	DC h9	DC h9	DC h9	DC h9	DC h9	DC h9	DC h9	DC h9	DC h9	DC h9	DC h9	
Direction de coupe												
Groupe standard de base (BSG)												

Code de famille de produits		S501	S511	S229	S231	S233	S629	S529	S531	S533	S534	S535	S791
		1.00 – 16.00	3.00 – 16.00	1.50 – 16.00	1.50 – 16.00	2.00 – 16.00	1.00 – 20.00	1.50 – 16.00	1.50 – 16.00	2.00 – 16.00	3.00 – 16.00	3.00 – 16.00	6.00 – 16.00
Plage de diamètres de coupe PSF		154	155	156	157	158	159	160	161	162	163	164	165
P	P1	■	■										■
	P2	■	■										■
	P3	■	■										■
	P4	■	■	▣	▣	▣							■
M	M1	■	■										■
	M2	■	■	■	■	■							■
	M3	▣	▣	■	■	■							▣
	M4	▣	▣	■	■	■							▣
K	K1	■	■										■
	K2	■	■										■
	K3	■	■										■
	K4	■	■										■
	K5	■	■										■
N	N1	▣	▣				■						▣
	N2	▣	▣				■						▣
	N3	■	■				■						■
	N4	▣	▣				■						▣
	N5												
S	S1	▣	▣	■	■	■							▣
	S2	▣	▣	■	■	■							▣
	S3	▣	▣	■	■	■							▣
	S4	▣	▣	■	■	■							▣
H	H1							■	■	■	■	■	
	H2							■	■	■	■	■	
	H3							■	■	■	■	■	
	H4							■	■	■	■	■	

S501

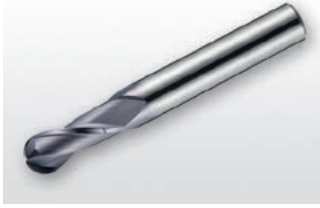

Fraise à bout hémisphérique en carbure monobloc à 2 dents

Fraise à 2 dents avec une longueur de coupe courte diminuant les vibrations et offrant une résistance accrue. La géométrie à bout hémisphérique est conçue pour un contournage haute performance de surfaces complexes. Le revêtement X-CEED améliore les performances de fraisage des matériaux difficiles à usiner.

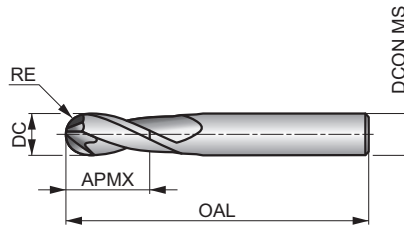

HM	N	NOF 2
	λ 30°	γ 10°
DIN 6535HA	X-CEED	DC h9



Adéquation du groupe de matériaux de la pièce, valeurs de départ pour la vitesse de coupe (m/min) et code alpha. Tableaux d'avances par dent et facteurs de correction à partir de la page 266.

P1.1 ■ 161 F	P1.2 ■ 181 F	P1.3 ■ 186 F	P2.1 ■ 138 F	P2.2 ■ 121 F	P2.3 ■ 108 F	P3.1 ■ 112 F	P3.2 ■ 90 F	P3.3 ■ 76 F	P4.1 ■ 66 F	P4.2 ■ 57 F	P4.3 ▣ 46 F	M1.1 ■ 94 F	M1.2 ■ 79 F
M2.1 ■ 83 F	M2.2 ■ 69 F	M3.1 ▣ 77 F	M3.2 ▣ 66 F	M3.3 ▣ 59 E	M4.1 ▣ 58 E	K1.1 ■ 161 F	K1.2 ■ 119 F	K1.3 ■ 89 F	K2.1 ■ 165 F	K2.2 ■ 134 F	K2.3 ■ 107 F	K3.1 ■ 146 F	K3.2 ■ 112 F
K3.3 ■ 90 F	K4.1 ■ 136 F	K4.2 ■ 102 F	K4.3 ■ 75 F	K4.4 ■ 64 E	K4.5 ■ 54 E	K5.1 ■ 154 F	K5.2 ■ 115 F	K5.3 ■ 89 F	N1.1 ▣ 355 G	N1.2 ▣ 267 G	N1.3 ▣ 179 G	N2.1 ▣ 179 F	N2.2 ▣ 160 F
N2.3 ▣ 115 F	N3.1 ■ 187 F	N3.2 ■ 109 F	N3.3 ▣ 56 F	N4.1 ▣ 187 F	N4.2 ▣ 72 F	S1.1 ▣ 126 F	S1.2 ▣ 112 F	S2.1 ▣ 186 E	S3.1 ▣ 65 E	S4.1 ▣ 51 E			

DCON MS tolérance h6; RE ±0.01 mm.

Product	DC (mm)	RE (mm)	DCON MS (mm)	APMX (mm)	OAL (mm)	NOF
S5011.0	1.00	0.50	3.00	3.00	38.0	2
S5011.5	1.50	0.75	3.00	3.00	38.0	2
S5012.0	2.00	1.00	3.00	6.00	38.0	2
S5012.5	2.50	1.25	3.00	7.00	38.0	2
S5013.0	3.00	1.50	3.00	7.00	38.0	2
S5014.0	4.00	2.00	6.00	8.00	57.0	2
S5015.0	5.00	2.50	6.00	10.00	57.0	2
S5016.0	6.00	3.00	6.00	10.00	57.0	2
S5017.0	7.00	3.50	8.00	13.00	63.0	2
S5018.0	8.00	4.00	8.00	16.00	63.0	2
S5019.0	9.00	4.50	10.00	16.00	72.0	2
S50110.0	10.00	5.00	10.00	19.00	72.0	2
S50112.0	12.00	6.00	12.00	22.00	83.0	2
S50116.0	16.00	8.00	16.00	26.00	92.0	2

S511



Fraise à bout hémisphérique en carbure monobloc à 4 dents, portée extra longue

Fraise à 4 dents avec une longueur de coupe courte et une portée extra longue offrant une grande rigidité pour une résistance accrue et des vibrations réduites dans les applications plus profondes. La géométrie à bout hémisphérique est conçue pour un contournage haute performance de surfaces complexes. Le revêtement X-CEED améliore les performances de fraisage des matériaux difficiles à usiner.

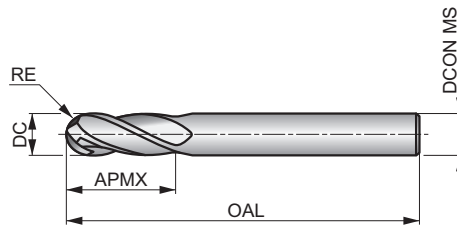

HM	N	NOF 4
	λ 30°	γ 10°
DIN 6335HA	X-CEED	DC h9



Adéquation du groupe de matériaux de la pièce, valeurs de départ pour la vitesse de coupe (m/min) et code alpha. Tableaux d'avances par dent et facteurs de correction à partir de la page 266.

P1.1 ■ 161 E	P1.2 ■ 181 E	P1.3 ■ 186 E	P2.1 ■ 138 E	P2.2 ■ 121 E	P2.3 ■ 108 E	P3.1 ■ 112 E	P3.2 ■ 90 E	P3.3 ■ 76 E	P4.1 ■ 66 E	P4.2 ■ 57 E	P4.3 ▣ 46 E	M1.1 ■ 94 E	M1.2 ■ 79 E
M2.1 ■ 83 E	M2.2 ■ 69 E	M3.1 ▣ 77 E	M3.2 ▣ 66 E	M3.3 ▣ 59 D	M4.1 ▣ 58 D	K1.1 ■ 161 E	K1.2 ■ 119 E	K1.3 ■ 89 E	K2.1 ■ 165 E	K2.2 ■ 134 E	K2.3 ■ 107 E	K3.1 ■ 146 E	K3.2 ■ 112 E
K3.3 ■ 90 E	K4.1 ■ 136 E	K4.2 ■ 102 E	K4.3 ■ 75 E	K4.4 ■ 64 D	K4.5 ■ 54 D	K5.1 ■ 154 E	K5.2 ■ 115 E	K5.3 ■ 89 E	N1.1 ▣ 355 F	N1.2 ▣ 267 F	N1.3 ▣ 179 F	N2.1 ▣ 179 E	N2.2 ▣ 160 E
N2.3 ▣ 115 E	N3.1 ■ 187 E	N3.2 ■ 109 E	N3.3 ▣ 56 E	N4.1 ▣ 187 E	N4.2 ▣ 72 E	S1.1 ▣ 126 E	S1.2 ▣ 112 E	S2.1 ▣ 186 D	S3.1 ▣ 65 D	S4.1 ▣ 51 D			

DCON MS tolérance h6; RE +0/-0.01 mm.

Product	DC (mm)	RE (mm)	DCON MS (mm)	APMX (mm)	OAL (mm)	NOF
S5113.0	3.00	1.50	6.00	8.00	80.0	4
S5114.0	4.00	2.00	6.00	11.00	80.0	4
S5115.0	5.00	2.50	6.00	13.00	80.0	4
S5116.0	6.00	3.00	6.00	13.00	80.0	4
S5117.0	7.00	3.50	8.00	16.00	100.0	4
S5118.0	8.00	4.00	8.00	19.00	100.0	4
S5119.0	9.00	4.50	10.00	19.00	100.0	4
S51110.0	10.00	5.00	10.00	22.00	100.0	4
S51112.0	12.00	6.00	12.00	26.00	100.0	4
S51116.0	16.00	8.00	16.00	32.00	100.0	4

S229



Fraise à bout hémisphérique en carbure monobloc à 2 dents

Fraise à 2 dents avec une longueur de coupe extra courte et un détalonnage offrant une grande rigidité et réduisant les vibrations. La géométrie à bout hémisphérique est conçue pour le contournage haute performance de surfaces complexes. Le revêtement TiSiN augmente la durée de vie de la fraise et améliore les performances lors du fraisage de matériaux difficiles à usiner.

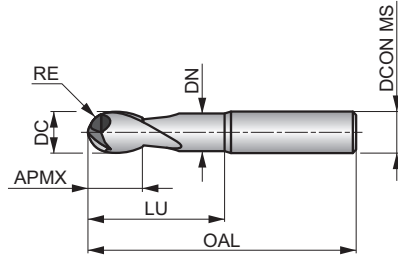

HM	N	NOF 2
	λ 30°	γ 3°
DIN 6535HA	TiSiN	DC h9



Adéquation du groupe de matériaux de la pièce, valeurs de départ pour la vitesse de coupe (m/min) et code alpha. Tableaux d'avances par dent et facteurs de correction à partir de la page 266.

P4.3	M2.3	M3.3	M4.1	M4.2	S1.3	S2.2	S3.2	S4.2
■ 80 F	■ 80 F	■ 82 F	■ 80 F	■ 68 F	■ 58 F	■ 47 F	■ 33 F	■ 27 F

DCON MS tolérance h6; RE +0/-0.02 mm.

Product	DC (mm)	RE (mm)	DCON MS (mm)	APMX (mm)	OAL (mm)	NOF	LU (mm)	DN (mm)
S2291.5XD4	1.50	0.75	4.00	3.00	50.0	2	6.00	1.40
S2292.0XD3	2.00	1.00	3.00	4.00	50.0	2	8.00	1.90
S2292.0XD4	2.00	1.00	4.00	4.00	50.0	2	8.00	1.90
S2293.0XD3	3.00	1.50	3.00	5.00	50.0	2	14.00	2.80
S2293.0XD6	3.00	1.50	6.00	5.00	50.0	2	14.00	2.80
S2294.0XD4	4.00	2.00	4.00	8.00	50.0	2	20.00	3.70
S2294.0XD6	4.00	2.00	6.00	8.00	50.0	2	20.00	3.70
S2295.0XD5	5.00	2.50	5.00	9.00	50.0	2	20.00	4.60
S2295.0XD6	5.00	2.50	6.00	9.00	50.0	2	20.00	4.60
S2296.0	6.00	3.00	6.00	10.00	50.0	2	20.00	5.50
S2298.0	8.00	4.00	8.00	12.00	64.0	2	30.00	7.40
S22910.0	10.00	5.00	10.00	14.00	70.0	2	32.00	9.20
S22912.0	12.00	6.00	12.00	16.00	75.0	2	38.00	11.00
S22914.0	14.00	7.00	14.00	32.00	90.0	2	44.00	13.00
S22916.0	16.00	8.00	16.00	32.00	90.0	2	46.00	15.00

S231



Fraise à bout hémisphérique en carbure monobloc à 2 dents, longue portée

Fraise à 2 dents avec une longueur de coupe extra courte sur une portée longue avec un détalonnage offrant une grande rigidité et réduisant les vibrations. La géométrie à bout hémisphérique est conçue pour le contourage haute performance de surfaces complexes. Le revêtement TiSiN augmente la durée de vie de l'outil et améliore les performances lors du fraisage de matériaux difficiles à usiner.

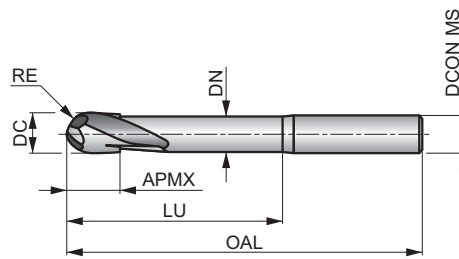

HM	N	NOF 2
	λ 30°	γ 3°
DIN 6535HA	TiSiN	DC h9



Adéquation du groupe de matériaux de la pièce, valeurs de départ pour la vitesse de coupe (m/min) et code alpha. Tableaux d'avances par dent et facteurs de correction à partir de la page 266.

P4.3	M2.3	M3.3	M4.1	M4.2	S1.3	S2.2	S3.2	S4.2
■ 64 F	■ 64 F	■ 65 F	■ 64 F	■ 54 F	■ 46 F	■ 38 F	■ 26 F	■ 22 F

DCON MS tolérance h6; RE +0/-0.02 mm.

Product	DC (mm)	RE (mm)	DCON MS (mm)	APMX (mm)	OAL (mm)	NOF	LU (mm)	DN (mm)
S2311.5XD4	1.50	0.75	4.00	3.00	75.0	2	10.00	1.40
S2312.0XD3	2.00	1.00	3.00	4.00	60.0	2	14.00	1.90
S2312.0XD4	2.00	1.00	4.00	4.00	75.0	2	14.00	1.90
S2313.0XD3	3.00	1.50	3.00	5.00	60.0	2	21.00	2.80
S2313.0XD6	3.00	1.50	6.00	5.00	75.0	2	21.00	2.80
S2314.0XD4	4.00	2.00	4.00	8.00	60.0	2	28.00	3.70
S2314.0XD6	4.00	2.00	6.00	8.00	75.0	2	28.00	3.70
S2315.0	5.00	2.50	5.00	9.00	60.0	2	32.00	4.60
S2316.0	6.00	3.00	6.00	10.00	75.0	2	40.00	5.50
S2318.0	8.00	4.00	8.00	10.00	75.0	2	40.00	7.40
S23110.0	10.00	5.00	10.00	12.00	75.0	2	40.00	9.20
S23112.0	12.00	6.00	12.00	16.00	100.0	2	60.00	11.00
S23116.0	16.00	8.00	16.00	32.00	125.0	2	80.00	15.00

S233

DORMER



Fraise à bout hémisphérique en carbure monobloc à 2 dents, portée extra longue

Fraise à 2 dents avec une longueur de coupe extra courte sur une portée extra longue avec un détalonnage offrant une grande rigidité et réduisant les vibrations. La géométrie à bout hémisphérique est conçue pour le contournage haute performance de surfaces complexes. Le revêtement TiSiN augmente la durée de vie de l'outil et améliore les performances lors du fraisage de matériaux difficiles à usiner.

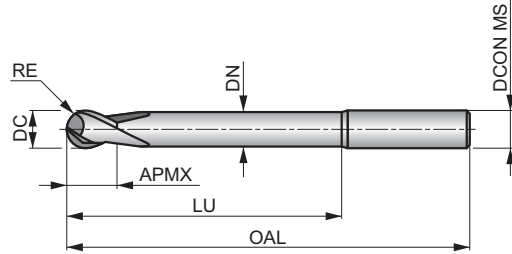

HM	N	NOF 2
	λ 30°	γ 3°
DIN 6535HA	TiSiN	DC h9



Adéquation du groupe de matériaux de la pièce, valeurs de départ pour la vitesse de coupe (m/min) et code alpha. Tableaux d'avances par dent et facteurs de correction à partir de la page 266.

P4.3 ■ 40 F	M2.3 ■ 40 F	M3.3 ■ 41 F	M4.1 ■ 40 F	M4.2 ■ 34 F	S1.3 ■ 29 F	S2.2 ■ 24 F	S3.2 ■ 17 F	S4.2 ■ 14 F
-----------------------	-----------------------	-----------------------	-----------------------	-----------------------	-----------------------	-----------------------	-----------------------	-----------------------

DCON MS tolérance h6; RE +0/-0.02 mm.

Product	DC (mm)	RE (mm)	DCON MS (mm)	APMX (mm)	OAL (mm)	NOF	LU (mm)	DN (mm)
S2332.0XD3	2.00	1.00	3.00	4.00	100.0	2	20.00	1.90
S2332.0XD4	2.00	1.00	4.00	4.00	100.0	2	20.00	1.90
S2333.0XD3	3.00	1.50	3.00	5.00	100.0	2	30.00	2.80
S2333.0XD6	3.00	1.50	6.00	5.00	100.0	2	30.00	2.80
S2334.0XD4	4.00	2.00	4.00	8.00	100.0	2	40.00	3.70
S2334.0XD6	4.00	2.00	6.00	8.00	100.0	2	40.00	3.70
S2335.0	5.00	2.50	5.00	9.00	100.0	2	50.00	4.60
S2336.0	6.00	3.00	6.00	10.00	100.0	2	60.00	5.50
S2338.0	8.00	4.00	8.00	12.00	100.0	2	60.00	7.40
S23310.0	10.00	5.00	10.00	14.00	125.0	2	85.00	9.20
S23312.0	12.00	6.00	12.00	16.00	125.0	2	85.00	11.00
S23314.0	14.00	7.00	14.00	32.00	150.0	2	110.00	13.00
S23316.0	16.00	8.00	16.00	32.00	150.0	2	110.00	15.00

S629



Fraise à bout hémisphérique en carbure monobloc à 2 dents

Fraise à 2 dents avec une longueur de coupe extra courte et un détalonnage offrant une grande rigidité et réduisant les vibrations. La géométrie à bout hémisphérique est conçue pour le contournage haute performance de surfaces complexes dans les matériaux non-ferreux.

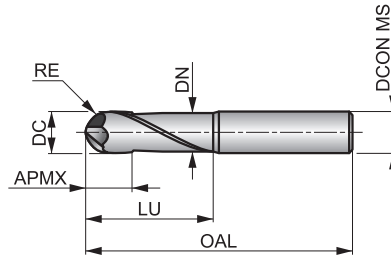

HM	W	NOF 2
	λ 30°	γ 15°
DIN 6535HA	Bright	DC h9



Adéquation du groupe de matériaux de la pièce, valeurs de départ pour la vitesse de coupe (m/min) et code alpha. Tableaux d'avances par dent et facteurs de correction à partir de la page 266.

N1.1	N1.2	N1.3	N2.1	N2.2	N2.3	N3.1	N3.2	N3.3	N4.1	N4.2
■ 709 N	■ 533 N	■ 357 N	■ 357 N	■ 320 N	■ 229 N	■ 373 N	■ 219 N	■ 112 N	■ 373 0	■ 144 0

DCON MS tolérance h6; RE +0/-0.02 mm.

Product	DC (mm)	RE (mm)	DCON MS (mm)	APMX (mm)	OAL (mm)	NOF	LU (mm)	DN (mm)
S6291.0 ¹⁾	1.00	0.50	4.00	0.80	50.0	2	10.00	0.90
S6291.5 ¹⁾	1.50	0.75	4.00	1.20	50.0	2	12.00	1.40
S6292.0 ¹⁾	2.00	1.00	4.00	1.60	60.0	2	18.00	1.90
S6293.0	3.00	1.50	6.00	5.00	57.0	2	20.00	2.80
S6294.0	4.00	2.00	6.00	6.00	57.0	2	20.00	3.70
S6295.0	5.00	2.50	6.00	7.00	57.0	2	20.00	4.60
S6296.0	6.00	3.00	6.00	8.00	57.0	2	20.00	5.50
S6298.0	8.00	4.00	8.00	10.00	64.0	2	25.00	7.40
S62910.0	10.00	5.00	10.00	12.00	75.0	2	35.00	9.20
S62912.0	12.00	6.00	12.00	14.00	75.0	2	35.00	11.00
S62916.0	16.00	8.00	16.00	18.00	90.0	2	45.00	15.00
S62920.0	20.00	10.00	20.00	22.00	100.0	2	50.00	19.00

¹⁾ angle de coupe 11°.

S529



Fraise à bout hémisphérique en carbure monobloc à 2 dents

Fraise à 2 dents avec une longueur de coupe extra courte et un détalonnage offrant une grande rigidité et réduisant les vibrations. La géométrie à bout hémisphérique est conçue pour le contourage haute performance de surfaces complexes. Le revêtement TiSiN augmente la durée de vie de l'outil et améliore les performances lors de l'usinage de matériaux trempés jusqu'à 63 HRC.

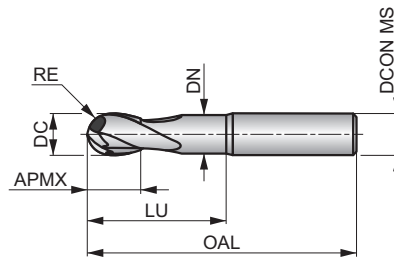

HM	N	NOF 2
	λ 30°	γ -10°
DIN 6535HA	TiSiN	DC h9



Adéquation du groupe de matériaux de la pièce, valeurs de départ pour la vitesse de coupe (m/min) et code alpha. Tableaux d'avances par dent et facteurs de correction à partir de la page 266.

H1.1	H2.1	H2.2	H3.1	H3.2	H4.1	H4.2
■ 119 F	■ 70 E	■ 60 D	■ 78 E	■ 64 E	■ 50 D	■ 42 A

DCON MS tolérance h6; RE +0/-0.02 mm.

Product	DC (mm)	RE (mm)	DCON MS (mm)	APMX (mm)	OAL (mm)	NOF	LU (mm)	DN (mm)
S5291.5	1.50	0.75	6.00	3.00	50.0	2	6.00	1.40
S5292.0XD4	2.00	1.00	4.00	4.00	50.0	2	8.00	1.90
S5292.0XD6	2.00	1.00	6.00	4.00	50.0	2	8.00	1.90
S5293.0XD3	3.00	1.50	3.00	5.00	50.0	2	14.00	2.80
S5293.0XD6	3.00	1.50	6.00	5.00	50.0	2	14.00	2.80
S5294.0XD4	4.00	2.00	4.00	8.00	50.0	2	20.00	3.70
S5294.0XD6	4.00	2.00	6.00	8.00	50.0	2	20.00	3.70
S5295.0XD5	5.00	2.50	5.00	9.00	50.0	2	20.00	4.60
S5295.0XD6	5.00	2.50	6.00	9.00	50.0	2	20.00	4.60
S5296.0	6.00	3.00	6.00	10.00	50.0	2	20.00	5.50
S5298.0	8.00	4.00	8.00	12.00	64.0	2	30.00	7.40
S52910.0	10.00	5.00	10.00	14.00	70.0	2	32.00	9.20
S52912.0	12.00	6.00	12.00	16.00	75.0	2	38.00	11.00
S52916.0	16.00	8.00	16.00	32.00	90.0	2	46.00	15.00

S531

DORMER



Fraise à bout hémisphérique en carbure monobloc à 2 dents, longue portée

Fraise à 2 dents avec une longueur de coupe extra courte sur une portée longue avec un détalonnage offrant une grande rigidité et réduisant les vibrations. La géométrie à bout hémisphérique est conçue pour le contourage haute performance de surfaces complexes. Le revêtement TiSiN augmente la durée de vie de l'outil et améliore les performances lors de l'usinage de matériaux trempés jusqu'à 63 HRC.

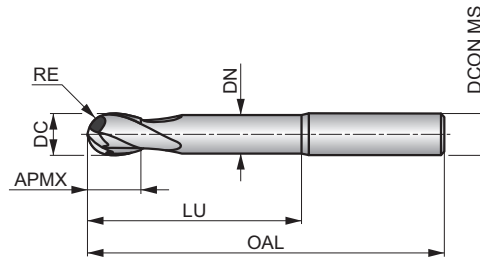

HM	N	NOF 2
	λ 30°	γ -10°
DIN 6535HA	TiSiN	DC h9



Adéquation du groupe de matériaux de la pièce, valeurs de départ pour la vitesse de coupe (m/min) et code alpha. Tableaux d'avances par dent et facteurs de correction à partir de la page 266.

H1.1 ■ 96 F	H2.1 ■ 57 E	H2.2 ■ 49 D	H3.1 ■ 63 E	H3.2 ■ 52 E	H4.1 ■ 40 D	H4.2 ■ 34 A
-----------------------	-----------------------	-----------------------	-----------------------	-----------------------	-----------------------	-----------------------

DCON MS tolérance h6; RE +0/-0.02 mm.

Product	DC (mm)	RE (mm)	DCON MS (mm)	APMX (mm)	OAL (mm)	NOF	LU (mm)	DN (mm)
S5311.5	1.50	0.75	6.00	3.00	75.0	2	10.00	1.40
S5312.0XD4	2.00	1.00	4.00	4.00	75.0	2	14.00	1.90
S5312.0XD6	2.00	1.00	6.00	4.00	75.0	2	14.00	1.90
S5313.0XD3	3.00	1.50	3.00	5.00	60.0	2	21.00	2.80
S5313.0XD6	3.00	1.50	6.00	5.00	75.0	2	21.00	2.80
S5314.0XD4	4.00	2.00	4.00	8.00	60.0	2	28.00	3.70
S5314.0XD6	4.00	2.00	6.00	8.00	75.0	2	28.00	3.70
S5315.0XD5	5.00	2.50	5.00	9.00	60.0	2	32.00	4.60
S5315.0XD6	5.00	2.50	6.00	9.00	75.0	2	32.00	4.60
S5316.0	6.00	3.00	6.00	10.00	75.0	2	40.00	5.50
S5318.0	8.00	4.00	8.00	12.00	75.0	2	40.00	7.40
S53110.0	10.00	5.00	10.00	14.00	75.0	2	40.00	9.20
S53112.0	12.00	6.00	12.00	16.00	100.0	2	60.00	11.00
S53116.0	16.00	8.00	16.00	32.00	125.0	2	80.00	15.00

S533

DORMER



Fraise à bout hémisphérique en carbure monobloc à 2 dents, portée extra longue

Fraise à 2 dents avec une longueur de coupe extra courte sur une portée extra longue avec un détalonnage offrant une grande rigidité et réduisant les vibrations. La géométrie à bout hémisphérique est conçue pour le contournage haute performance de surfaces complexes. Le revêtement TiSiN augmente la durée de vie de l'outil et améliore les performances lors de l'usinage de matériaux trempés jusqu'à 63 HRC.

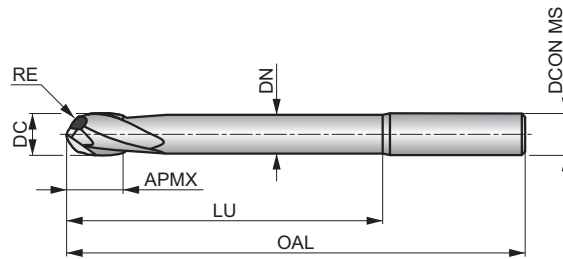

HM	N	NOF 2
	λ 30°	γ -10°
DIN 6535HA	TiSiN	DC h9



Adéquation du groupe de matériaux de la pièce, valeurs de départ pour la vitesse de coupe (m/min) et code alpha. Tableaux d'avances par dent et facteurs de correction à partir de la page 266.

H1.1 ■ 59 F	H2.1 ■ 35 E	H2.2 ■ 30 D	H3.1 ■ 39 E	H3.2 ■ 32 E	H4.1 ■ 25 D	H4.2 ■ 21 A
-----------------------	-----------------------	-----------------------	-----------------------	-----------------------	-----------------------	-----------------------

DCON MS tolérance h6; RE +0/-0.02 mm.

Product	DC (mm)	RE (mm)	DCON MS (mm)	APMX (mm)	OAL (mm)	NOF	LU (mm)	DN (mm)
S5332.0XD4	2.00	1.00	4.00	4.00	100.0	2	20.00	1.90
S5332.0XD6	2.00	1.00	6.00	4.00	100.0	2	20.00	1.90
S5333.0XD4	3.00	1.50	4.00	5.00	100.0	2	30.00	2.80
S5333.0XD6	3.00	1.50	6.00	5.00	100.0	2	30.00	2.80
S5334.0XD4	4.00	2.00	4.00	8.00	100.0	2	40.00	3.70
S5334.0XD6	4.00	2.00	6.00	8.00	100.0	2	40.00	3.70
S5335.0XD5	5.00	2.50	5.00	9.00	100.0	2	50.00	4.60
S5335.0XD6	5.00	2.50	6.00	9.00	100.0	2	50.00	4.60
S5336.0	6.00	3.00	6.00	10.00	100.0	2	60.00	5.50
S5338.0	8.00	4.00	8.00	12.00	100.0	2	60.00	7.40
S53310.0	10.00	5.00	10.00	14.00	125.0	2	85.00	9.20
S53312.0	12.00	6.00	12.00	16.00	125.0	2	85.00	11.00
S53314.0	14.00	7.00	14.00	32.00	150.0	2	110.00	13.00
S53316.0	16.00	8.00	16.00	32.00	150.0	2	110.00	15.00

S534



Fraise à bout hémisphérique en carbure monobloc à 4 dents

Fraise à 4 dents avec une longueur de coupe extra courte et un détalonnage réduisant les vibrations et assurant une grande rigidité. La géométrie à bout hémisphérique est conçue pour le contournage haute performance de surfaces complexes. Le revêtement TiSiN augmente la durée de vie de l'outil et améliore les performances lors de l'usinage de matériaux trempés jusqu'à 63 HRC.

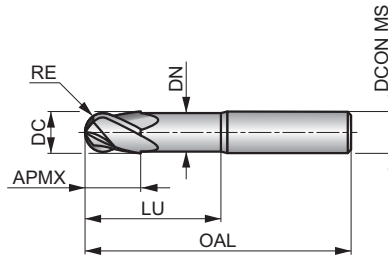

HM	N	NOF 4
	λ 30°	γ -10°
DIN 6358A	TiSiN	DC h9



Adéquation du groupe de matériaux de la pièce, valeurs de départ pour la vitesse de coupe (m/min) et code alpha. Tableaux d'avances par dent et facteurs de correction à partir de la page 266.

H1.1	H2.1	H2.2	H3.1	H3.2	H4.1	H4.2
■ 119 E	■ 70 D	■ 60 C	■ 78 D	■ 64 D	■ 50 C	■ 42 A

DCON MS tolérance h6; RE +0/-0.02 mm.

Product	DC (mm)	RE (mm)	DCON MS (mm)	APMX (mm)	OAL (mm)	NOF	LU (mm)	DN (mm)
S5343.0	3.00	1.50	6.00	5.00	50.0	4	14.00	2.80
S5344.0	4.00	2.00	6.00	8.00	50.0	4	20.00	3.70
S5345.0	5.00	2.50	6.00	9.00	50.0	4	20.00	4.60
S5346.0	6.00	3.00	6.00	10.00	50.0	4	20.00	5.50
S5348.0	8.00	4.00	8.00	12.00	64.0	4	30.00	7.40
S53410.0	10.00	5.00	10.00	14.00	70.0	4	32.00	9.20
S53412.0	12.00	6.00	12.00	16.00	75.0	4	38.00	11.00
S53414.0	14.00	7.00	14.00	32.00	90.0	4	44.00	13.00
S53416.0	16.00	8.00	16.00	32.00	90.0	4	46.00	15.00

S535

DORMER



Fraise à bout hémisphérique en carbure monobloc à 4 dents, longue portée

Fraise à 4 dents avec une longueur de coupe extra courte sur une portée longue avec un détalonnage offrant une grande rigidité et réduisant les vibrations. La géométrie à bout hémisphérique est conçue pour le contourage haute performance de surfaces complexes. Le revêtement TiSiN augmente la durée de vie de l'outil et améliore les performances lors de l'usinage de matériaux trempés jusqu'à 63 HRC.

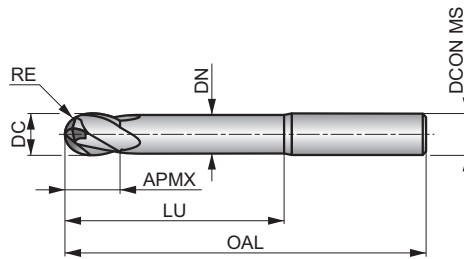

HM	N	NOF 4
	λ 30°	γ -10°
DIN 6535HA	TiSiN	DC h9



Adéquation du groupe de matériaux de la pièce, valeurs de départ pour la vitesse de coupe (m/min) et code alpha. Tableaux d'avances par dent et facteurs de correction à partir de la page 266.

H1.1	H2.1	H2.2	H3.1	H3.2	H4.1	H4.2
■ 96 E	■ 57 D	■ 49 C	■ 63 D	■ 52 D	■ 40 C	■ 34 A

DCON MS tolérance h6; RE +0/-0.02 mm.

Product	DC (mm)	RE (mm)	DCON MS (mm)	APMX (mm)	OAL (mm)	NOF	LU (mm)	DN (mm)
S5353.0	3.00	1.50	6.00	5.00	75.0	4	21.00	2.80
S5354.0	4.00	2.00	6.00	8.00	75.0	4	28.00	3.70
S5355.0	5.00	2.50	6.00	9.00	75.0	4	32.00	4.60
S5356.0	6.00	3.00	6.00	10.00	75.0	4	40.00	5.50
S5358.0	8.00	4.00	8.00	12.00	75.0	4	40.00	7.40
S53510.0	10.00	5.00	10.00	14.00	75.0	4	40.00	9.20
S53512.0	12.00	6.00	12.00	16.00	100.0	4	60.00	11.00
S53514.0	14.00	7.00	14.00	32.00	125.0	4	80.00	13.00
S53516.0	16.00	8.00	16.00	32.00	125.0	4	80.00	15.00

S791



Fraise tonneau en carbure monobloc à 3, 4 dents

Fraise à 3 ou 4 dents avec une longueur de coupe moyenne sur un grand rayon tangentiel et un bout hémisphérique augmentant le contact avec la pièce à usiner afin de réduire le temps de cycle et d'améliorer la finition de surface des parois profondes. Le revêtement AlCrN améliore les performances et prolonge la durée de vie de l'outil. Pour les opérations de semi-finition et de finition.

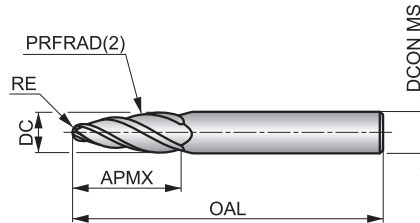

HM	N	NOF 3-4
	λ 30°	γ 8°
DIN 6335HA	AlCrN	
DORMER		



Adéquation du groupe de matériaux de la pièce, valeurs de départ pour la vitesse de coupe (m/min) et code alpha. Tableaux d'avances par dent et facteurs de correction à partir de la page 266.

P1.1 ■ 161 F	P1.2 ■ 181 F	P1.3 ■ 186 F	P2.1 ■ 138 F	P2.2 ■ 121 F	P2.3 ■ 108 E	P3.1 ■ 112 F	P3.2 ■ 90 E	P3.3 ■ 76 E	P4.1 ■ 66 E	P4.2 ■ 57 E	P4.3 ▣ 46 E	M1.1 ■ 94 F	M1.2 ■ 79 F
M2.1 ■ 83 F	M2.2 ■ 69 E	M3.1 ▣ 77 E	M3.2 ▣ 66 E	M3.3 ▣ 59 E	M4.1 ▣ 58 E	K1.1 ■ 161 F	K1.2 ■ 119 F	K1.3 ■ 89 F	K2.1 ■ 165 F	K2.2 ■ 134 F	K2.3 ■ 107 E	K3.1 ■ 146 F	K3.2 ■ 112 F
K3.3 ■ 90 E	K4.1 ■ 136 E	K4.2 ■ 102 E	K4.3 ■ 75 E	K4.4 ■ 64 E	K4.5 ■ 54 E	K5.1 ■ 154 E	K5.2 ■ 115 E	K5.3 ■ 89 E	N1.1 ▣ 1355 I	N1.2 ▣ 1267 I	N1.3 ▣ 1179 I	N2.1 ▣ 1179 F	N2.2 ▣ 1160 F
N2.3 ▣ 115 F	N3.1 ■ 187 F	N3.2 ■ 109 F	N3.3 ▣ 56 F	N4.1 ▣ 187 F	N4.2 ▣ 72 F	S1.1 ▣ 58 E	S1.2 ▣ 56 E	S2.1 ▣ 43 E	S3.1 ▣ 33 E	S4.1 ▣ 26 E			

DCN MS tolérance h6; RE ±0.01 mm; PRFRAD(2) ±0.01 mm.

Product	DC (mm)	RE (mm)	PRFRAD(2) (mm)	DCN MS (mm)	APMX (mm)	OAL (mm)	NOF
S7916.0	6.00	1.00	95.0	6.00	22.00	67.0	3
S7918.0	8.00	1.00	90.0	8.00	25.00	75.0	3
S79110.0	10.00	2.00	85.0	10.00	26.00	75.0	4
S79112.0	12.00	2.00	80.0	12.00	28.00	83.0	4
S79116.0	16.00	3.00	75.0	16.00	31.00	90.0	4

Type de forme du filet (THFT)	M	M	M	M	MF	MF	UNC	UNF	NPT	G
Groupe standard de base (BSG)	DORMER	DORMER	DORMER	DORMER	DORMER	DORMER	DORMER	DORMER	DORMER	DORMER
Rapport longueur utile diamètre (ULDR)	2xD	2xD	2xD	2xD	1.5xD	1.5xD	2xD	2xD		1.5xD
Code de matériau du corps (BMC)	HM	HM	HM	HM	HM	HM	HM	HM	HM	HM
Géométrie de goujure (FDC)										
Angle d'hélice de goujure (FHA)	λ 10°	λ 10°	λ 27°	λ 27°	λ 10°	λ 10°	λ 10°	λ 10°	λ 10°	λ 10°
Sens (direction de coupe)	R	R	R	R	R	R	R	R	R	R
Revêtement	Alcrona Pro	Alcrona Pro	Alcrona Pro	Alcrona Pro	Alcrona Pro	Alcrona Pro	Alcrona Pro	Alcrona Pro	Alcrona Pro	Alcrona Pro
Queue	DIN 6535HA	DIN 6535HB	DIN 6535HA	DIN 6535HA	DIN 6535HA	DIN 6535HB	DIN 6535HB	DIN 6535HB	DIN 6535HB	DIN 6535HA
Code de type de sortie de liquide de coupe (CXSC)										

Code de famille de produits	J200	J205	J210	J215	J220	J225	J235	J245	J260	J280
Plage de diamètres de coupe PSF	M4 – M16	M8 – M16	M6 – M16	M6 – M16	M6 – M24	M12 – M18	1/4 – 3/4	1/4 – 3/4	1/8 – 2"	1/8 – 3"
	168	169	170	171	172	173	174	175	176	177

P	P1	■	■	■	■	■	■	■	■	■
	P2	■	■	■	■	■	■	■	■	■
	P3	■	■	■	■	■	■	■	■	■
	P4	■	■	■	■	■	■	■	■	■
M	M1	■	■	■	■	■	■	■	■	■
	M2	■	■	■	■	■	■	■	■	■
	M3	■	■	■	■	■	■	■	■	■
	M4	▣	▣	■	■	▣	▣	■	■	■
K	K1	■	■	■	■	■	■	■	■	■
	K2	■	■	■	■	■	■	■	■	■
	K3	■	■	■	■	■	■	■	■	■
	K4	■	■	■	■	■	■	■	■	■
	K5	■	■	■	■	■	■	■	■	■
N	N1	■	■	■	■	■	■	■	■	■
	N2	■	■	■	■	■	■	■	■	■
	N3	■	■	■	■	■	■	■	■	■
	N4	■	■	■	■	■	■	■	■	■
	N5	■	■	■	■	■	■	■	■	■
S	S1	▣	■	▣	■	▣	■	■	■	■
	S2	▣	▣	▣	▣	▣	▣	▣	▣	▣
	S3	▣	▣	▣	▣	▣	▣	▣	▣	▣
	S4	▣	▣	▣	▣	▣	▣	▣	▣	▣
H	H1	▣	▣	■	■	■	■	■	■	■
	H2									
	H3			▣	▣	▣	▣	▣	▣	▣
	H4									

J200



Fraise à fileter en Carbure Monobloc avec chanfrein, profil Métrique

Outil universel haute performance permettant d'usinier des diamètres identiques ou supérieurs à la taille de filet indiquée (TDZ) avec le même pas. A gauche ou à droite, trous débouchants ou borgnes presque jusqu'au fond. Avec chanfrein d'entrée à 60°. Revêtement Alcrona Pro pour un résultat d'usinage optimal dans une large gamme de matériaux

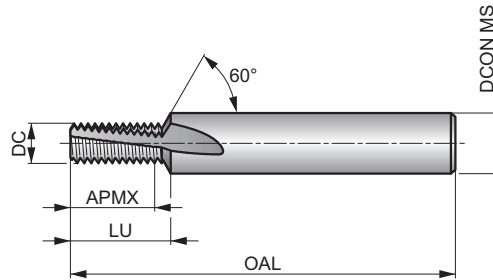

		2xD
HM		λ 10°
	Alcrona Pro	DIN 6535HA

Adéquation du groupe de matériaux de la pièce, valeurs de départ pour la vitesse de coupe (m/min) et code alpha. Tableaux d'avances par dent et facteurs de correction à partir de la page 266.

P1.1 ■ 172 B	P1.2 ■ 193 B	P1.3 ■ 200 B	P2.1 ■ 148 B	P2.2 ■ 130 B	P2.3 ■ 115 B	P3.1 ■ 133 B	P3.2 ■ 107 B	P3.3 ■ 90 B	P4.1 ■ 79 B	P4.2 ■ 67 B	P4.3 ▣ 55 B	M1.1 ■ 62 B	M1.2 ■ 52 B
M2.1 ■ 55 B	M2.2 ■ 45 B	M2.3 ▣ 38 B	M3.1 ■ 47 A	M3.2 ■ 40 A	M3.3 ▣ 36 A	M4.1 ■ 30 A	M4.2 ▣ 26 A	K1.1 ■ 130 B	K1.2 ■ 96 B	K1.3 ■ 72 B	K2.1 ■ 123 B	K2.2 ■ 100 B	K2.3 ■ 80 B
K3.1 ■ 109 B	K3.2 ■ 83 B	K3.3 ■ 67 B	K4.1 ■ 101 A	K4.2 ■ 76 A	K4.3 ■ 56 A	K4.4 ■ 48 A	K4.5 ▣ 40 A	K5.1 ■ 114 B	K5.2 ■ 86 B	K5.3 ■ 66 B	N1.1 ■ 400 C	N1.2 ■ 300 C	N1.3 ■ 200 C
N2.1 ■ 262 C	N2.2 ■ 235 C	N2.3 ■ 170 C	N3.1 ■ 610 C	N3.2 ■ 360 C	N3.3 ■ 180 C	N4.1 ■ 290 C	N4.2 ■ 145 C	N4.3 ■ 65 C	S1.1 ■ 40 A	S1.2 ▣ 40 A	S1.3 ▣ 30 A	S2.1 ▣ 33 A	S2.2 ▣ 25 A
S3.1 ▣ 25 A	S3.2 ▣ 21 A	S4.1 ▣ 20 A	S4.2 ▣ 16 A	H1.1 ▣ 60 A									

Filetage intérieur.

Product	TDZ	TP	DC	APMX	OAL	DCON MS	NOF	LU
		(mm)	(mm)	(mm)	(mm)	(mm)		(mm)
J2003.2X.7	M4	0.70	3.20	8.40	57.0	6.00	3	9.50
J2004.1X.8	M5	0.80	4.10	11.20	57.0	6.00	3	12.10
J2004.8X1.0	M6	1.00	4.80	13.00	63.0	8.00	3	14.40
J2006.5X1.25	M8	1.25	6.50	17.50	72.0	10.00	3	19.10
J2008.2X1.5	M10	1.50	8.20	21.00	83.0	12.00	3	22.80
J2009.9X1.75	M12	1.75	9.90	26.25	83.0	14.00	4	28.20
J20011.6X2.0	M14	2.00	11.60	30.00	92.0	16.00	4	32.20
J20013.6X2.0	M16	2.00	13.60	34.00	92.0	18.00	4	36.20

J205



Fraise à fileter Carbure Monobloc avec chanfrein, hélice à 10°, arrosage centralisé, profil Métrique

Outil universel haute performance permettant d'usinier des diamètres identiques ou supérieurs à la taille de filet indiquée (TDZ) avec le même pas. A gauche ou à droite, trous débouchants ou borgnes presque jusqu'au fond. Avec chanfrein d'entrée à 60°. Revêtement Alcrona Pro et arrosage centralisé pour une meilleure évacuation des copeaux et un résultat d'usinage optimal dans une large gamme de matériaux

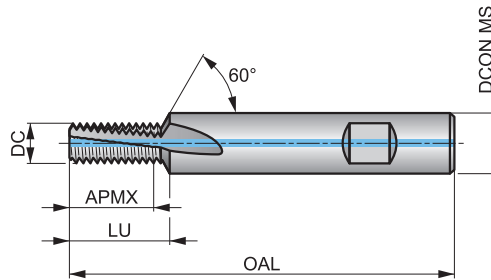

		2xD
HM		λ 10°
	Alcrona Pro	DIN 6535HB

Adéquation du groupe de matériaux de la pièce, valeurs de départ pour la vitesse de coupe (m/min) et code alpha. Tableaux d'avances par dent et facteurs de correction à partir de la page 266.

P1.1 ■ 172 B	P1.2 ■ 193 B	P1.3 ■ 200 B	P2.1 ■ 148 B	P2.2 ■ 130 B	P2.3 ■ 115 B	P3.1 ■ 133 B	P3.2 ■ 107 B	P3.3 ■ 90 B	P4.1 ■ 79 B	P4.2 ■ 67 B	P4.3 ▣ 55 B	M1.1 ■ 62 B	M1.2 ■ 52 B
M2.1 ■ 55 B	M2.2 ■ 45 B	M2.3 ■ 38 B	M3.1 ■ 47 A	M3.2 ■ 40 A	M3.3 ■ 36 A	M4.1 ■ 30 A	M4.2 ▣ 26 A	K1.1 ■ 130 B	K1.2 ■ 96 B	K1.3 ■ 72 B	K2.1 ■ 123 B	K2.2 ■ 100 B	K2.3 ■ 80 B
K3.1 ■ 109 B	K3.2 ■ 83 B	K3.3 ■ 67 B	K4.1 ■ 101 A	K4.2 ■ 76 A	K4.3 ■ 56 A	K4.4 ■ 48 A	K4.5 ▣ 40 A	K5.1 ■ 114 B	K5.2 ■ 86 B	K5.3 ■ 66 B	N1.1 ■ 400 C	N1.2 ■ 300 C	N1.3 ■ 200 C
N2.1 ■ 262 C	N2.2 ■ 235 C	N2.3 ■ 170 C	N3.1 ■ 610 C	N3.2 ■ 360 C	N3.3 ■ 180 C	N4.1 ■ 290 C	N4.2 ■ 145 C	N4.3 ■ 65 C	S1.1 ■ 40 A	S1.2 ■ 40 A	S1.3 ▣ 30 A	S2.1 ■ 33 A	S2.2 ▣ 25 A
S3.1 ■ 25 A	S3.2 ▣ 21 A	S4.1 ■ 20 A	S4.2 ▣ 16 A	H1.1 ▣ 60 A									

Filetage intérieur.

Product	TDZ	TP	DC	APMX	OAL	DCON MS	NOF	LU
		(mm)	(mm)	(mm)	(mm)	(mm)		(mm)
J2056.5X1.25	M8	1.25	6.50	17.50	72.0	10.00	3	19.10
J2058.2X1.50	M10	1.50	8.20	21.00	83.0	12.00	3	22.80
J2059.9X1.75	M12	1.75	9.90	26.25	83.0	14.00	4	28.20
J20511.6X2.0	M14	2.00	11.60	30.00	92.0	16.00	4	32.20
J20513.6X2.0	M16	2.00	13.60	34.00	92.0	18.00	4	36.20

J210



Fraise à fileter en Carbure Monobloc, angle d'hélice à 27°, profil Métrique

Outil universel haute performance permettant d'usinier des diamètres identiques ou supérieurs à la taille de filet indiquée (TDZ) avec le même pas. A gauche ou à droite, trous débouchants ou borgnes presque jusqu'au fond. Avec revêtement Alcrona Pro et une hélice de 27° pour une coupe plus douce et un meilleur résultat d'usinage dans une large gamme de matériaux

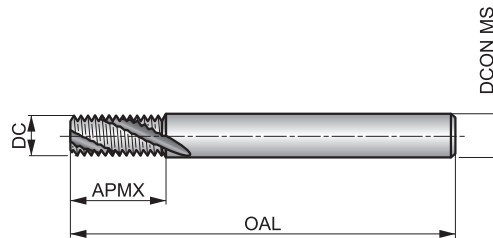

		2xD
HM		λ 27°
	Alcrona Pro	DIN 6535HA

Adéquation du groupe de matériaux de la pièce, valeurs de départ pour la vitesse de coupe (m/min) et code alpha. Tableaux d'avances par dent et facteurs de correction à partir de la page 266.

P1.1 ■ 181 B	P1.2 ■ 203 B	P1.3 ■ 210 B	P2.1 ■ 156 B	P2.2 ■ 137 B	P2.3 ■ 121 B	P3.1 ■ 140 B	P3.2 ■ 112 B	P3.3 ■ 95 B	P4.1 ■ 83 B	P4.2 ■ 70 B	P4.3 ▣ 58 B	M1.1 ■ 65 B	M1.2 ■ 55 B
M2.1 ■ 58 B	M2.2 ■ 47 B	M2.3 ▣ 40 B	M3.1 ■ 50 A	M3.2 ■ 42 A	M3.3 ▣ 38 A	M4.1 ■ 32 A	M4.2 ▣ 27 A	K1.1 ■ 137 B	K1.2 ■ 101 B	K1.3 ■ 76 B	K2.1 ■ 129 B	K2.2 ■ 105 B	K2.3 ■ 84 B
K3.1 ■ 115 B	K3.2 ■ 87 B	K3.3 ■ 71 B	K4.1 ■ 106 A	K4.2 ■ 80 A	K4.3 ■ 59 A	K4.4 ■ 51 A	K4.5 ▣ 42 A	K5.1 ■ 120 B	K5.2 ■ 90 B	K5.3 ■ 70 B	N1.1 ■ 420 C	N1.2 ■ 315 C	N1.3 ■ 210 C
N2.1 ■ 275 C	N2.2 ■ 247 C	N2.3 ■ 179 C	N3.1 ■ 640 C	N3.2 ■ 378 C	N3.3 ■ 189 C	N4.1 ■ 305 C	N4.2 ■ 153 C	N4.3 ■ 69 C	S1.1 ■ 42 A	S1.2 ▣ 42 A	S1.3 ▣ 32 A	S2.1 ▣ 35 A	S2.2 ▣ 26 A
S3.1 ▣ 26 A	S3.2 ▣ 22 A	S4.1 ▣ 21 A	S4.2 ▣ 17 A	H1.1 ■ 63 A	H3.1 ▣ 45 A								

Filetage intérieur.

Product	TDZ	TP	DC	APMX	OAL	DCON MS	NOF
		(mm)	(mm)	(mm)	(mm)	(mm)	
J2104.5X1.0	M6	1.00	4.50	13.00	57.0	6.00	3
J2106.0X1.25	M8	1.25	6.00	17.50	65.0	6.00	3
J2107.5X1.5	M10	1.50	7.50	21.00	72.0	8.00	3
J2109.5X1.75	M12	1.75	9.50	26.25	80.0	10.00	3
J21010.0X2.0	M14	2.00	10.00	30.00	83.0	10.00	4
J21012.0X2.0	M16	2.00	12.00	34.00	92.0	12.00	4

J215



Fraise à fileter en Carbure Monobloc, angle d'hélice à 27°, arrosage centralisé, profil Métrique

Outil universel haute performance permettant d'usinier des diamètres identiques ou supérieurs à la taille de filet indiquée (TDZ) avec le même pas. A gauche ou à droite, trous débouchants ou borgnes presque jusqu'au fond. Avec arrosage centralisé, revêtement Alcrona Pro et une hélice de 27° pour une coupe plus douce et un résultat d'usinage optimal dans une large gamme de matériaux

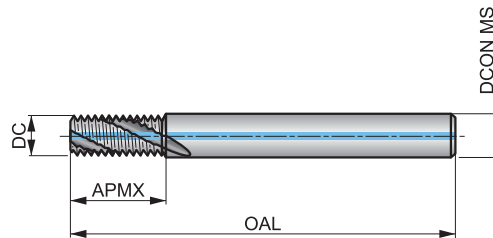

		2xD
HM		λ 27°
	Alcrona Pro	DIN 6535HA

Adéquation du groupe de matériaux de la pièce, valeurs de départ pour la vitesse de coupe (m/min) et code alpha. Tableaux d'avances par dent et facteurs de correction à partir de la page 266.

P1.1 ■ 181 B	P1.2 ■ 203 B	P1.3 ■ 210 B	P2.1 ■ 156 B	P2.2 ■ 137 B	P2.3 ■ 121 B	P3.1 ■ 140 B	P3.2 ■ 112 B	P3.3 ■ 95 B	P4.1 ■ 83 B	P4.2 ■ 70 B	P4.3 ■ 58 B	M1.1 ■ 65 B	M1.2 ■ 55 B
M2.1 ■ 58 B	M2.2 ■ 47 B	M2.3 ■ 40 B	M3.1 ■ 50 A	M3.2 ■ 42 A	M3.3 ■ 38 A	M4.1 ■ 32 A	M4.2 □ 27 A	K1.1 ■ 137 B	K1.2 ■ 101 B	K1.3 ■ 76 B	K2.1 ■ 129 B	K2.2 ■ 105 B	K2.3 ■ 84 B
K3.1 ■ 115 B	K3.2 ■ 87 B	K3.3 ■ 71 B	K4.1 ■ 106 A	K4.2 ■ 80 A	K4.3 ■ 59 A	K4.4 ■ 51 A	K4.5 ■ 42 A	K5.1 ■ 120 B	K5.2 ■ 90 B	K5.3 ■ 70 B	N1.1 ■ 420 C	N1.2 ■ 315 C	N1.3 ■ 210 C
N2.1 ■ 275 C	N2.2 ■ 247 C	N2.3 ■ 179 C	N3.1 ■ 640 C	N3.2 ■ 378 C	N3.3 ■ 189 C	N4.1 ■ 305 C	N4.2 ■ 153 C	N4.3 ■ 69 C	S1.1 ■ 42 A	S1.2 ■ 42 A	S1.3 □ 32 A	S2.1 ■ 35 A	S2.2 □ 26 A
S3.1 ■ 26 A	S3.2 □ 22 A	S4.1 ■ 21 A	S4.2 □ 17 A	H1.1 ■ 63 A	H3.1 □ 45 A								

Filetage intérieur.

Product	TDZ	TP	DC	APMX	OAL	DCON MS	NOF
		(mm)	(mm)	(mm)	(mm)	(mm)	
J2154.5X1.0	M6	1.00	4.50	13.00	57.0	6.00	3
J2156.0X1.25	M8	1.25	6.00	17.50	65.0	6.00	3
J2157.5X1.5	M10	1.50	7.50	21.00	72.0	8.00	3
J2159.5X1.75	M12	1.75	9.50	26.25	80.0	10.00	3
J21510.0X2.0	M14	2.00	10.00	30.00	83.0	10.00	4
J21512.0X2.0	M16	2.00	12.00	34.00	92.0	12.00	4

J220



Fraise à fileter en Carbure Monobloc, angle d'hélice à 10°, profil Métrique fin

Outil universel haute performance permettant d'usiner des diamètres identiques ou supérieurs à la taille de filet indiquée (TDZ) avec le même pas. A gauche ou à droite, trous débouchants ou borgnes presque jusqu'au fond. Avec revêtement Alcrona Pro pour un résultat d'usinage optimal dans une large gamme de matériaux.

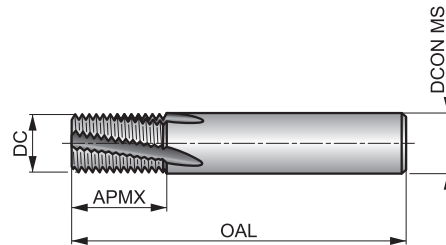

		1.5xD
HM		λ 10°

Adéquation du groupe de matériaux de la pièce, valeurs de départ pour la vitesse de coupe (m/min) et code alpha. Tableaux d'avances par dent et facteurs de correction à partir de la page 266.

P1.1 ■ 190 E	P1.2 ■ 212 E	P1.3 ■ 242 E	P2.1 ■ 163 E	P2.2 ■ 143 E	P2.3 ■ 127 E	P3.1 ■ 146 E	P3.2 ■ 118 E	P3.3 ■ 99 E	P4.1 ■ 87 E	P4.2 ■ 74 E	P4.3 ■ 61 E	M1.1 ■ 69 E	M1.2 ■ 58 E
M2.1 ■ 61 E	M2.2 ■ 50 E	M2.3 ▣ 42 E	M3.1 ■ 52 D	M3.2 ■ 44 D	M3.3 ▣ 40 D	M4.1 ■ 33 D	M4.2 ▣ 29 D	K1.1 ■ 143 E	K1.2 ■ 106 E	K1.3 ■ 80 E	K2.1 ■ 136 E	K2.2 ■ 110 E	K2.3 ■ 88 E
K3.1 ■ 120 E	K3.2 ■ 91 E	K3.3 ■ 74 E	K4.1 ■ 111 D	K4.2 ■ 84 D	K4.3 ■ 62 D	K4.4 ■ 53 D	K4.5 ▣ 44 D	K5.1 ■ 126 E	K5.2 ■ 95 E	K5.3 ■ 73 E	N1.1 ■ 440 F	N1.2 ■ 330 F	N1.3 ■ 220 F
N2.1 ■ 288 F	N2.2 ■ 259 F	N2.3 ■ 187 F	N3.1 ■ 671 F	N3.2 ■ 396 F	N3.3 ■ 198 F	N4.1 ■ 319 F	N4.2 ■ 160 F	N4.3 ■ 72 F	S1.1 ■ 44 D	S1.2 ▣ 44 D	S1.3 ▣ 33 D	S2.1 ▣ 36 D	S2.2 ▣ 28 D
S3.1 ▣ 28 D	S3.2 ▣ 23 D	S4.1 ▣ 22 D	S4.2 ▣ 18 D	H1.1 ■ 66 D	H3.1 ▣ 48 D								

Filetage intérieur.

Product	TDZ	TP	DC	APMX	OAL	DCON MS	NOF
		(mm)	(mm)	(mm)	(mm)	(mm)	
J2204.8X.5	M6	0.50	4.80	10.00	57.0	6.00	3
J2206.0X.75	M8	0.75	6.00	12.00	57.0	6.00	3
J2206.0X1.0	M8	1.00	6.00	12.00	57.0	6.00	3
J2208.0X1.0	M10	1.00	8.00	16.00	63.0	8.00	4
J22010.0X1.0	M12	1.00	10.00	20.00	72.0	10.00	4
J22010.0X1.5	M12	1.50	10.00	20.00	72.0	10.00	4
J22012.0X1.0	M14	1.00	12.00	22.00	83.0	12.00	4
J22012.0X1.5	M14	1.50	12.00	22.00	83.0	12.00	4
J22014.0X1.0	M16	1.00	14.00	26.00	83.0	14.00	5
J22014.0X1.5	M16	1.50	14.00	26.00	83.0	14.00	5
J22016.0X2.0	M20	2.00	16.00	30.00	92.0	16.00	5
J22016.0X2.5	M20	2.50	16.00	42.50	105.0	16.00	5
J22019.0X3.0	M24	3.00	19.00	50.00	125.0	20.00	5
J22020.0X2.0	M24	2.00	20.00	35.00	104.0	20.00	5

J225

DORMER



Fraise à fileter en Carbure Monobloc, arrosage centralisé, angle d'hélice à 10°, profil Métrique fin

Outil universel haute performance permettant d'usinier des diamètres identiques ou supérieurs à la taille de filet indiquée (TDZ) avec le même pas. A gauche ou à droite, trous débouchants ou borgnes presque jusqu'au fond. Avec revêtement Alcrona Pro et arrosage centralisé pour une meilleure évacuation des copeaux et un résultat d'usinage optimal dans une large gamme de matériaux

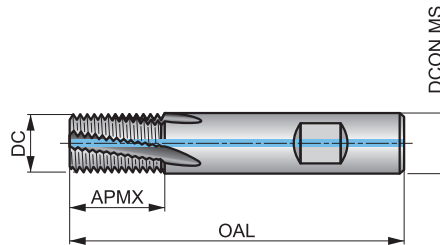

		1.5xD
HM		λ 10°

Adéquation du groupe de matériaux de la pièce, valeurs de départ pour la vitesse de coupe (m/min) et code alpha. Tableaux d'avances par dent et facteurs de correction à partir de la page 266.

P1.1 ■ 190 E	P1.2 ■ 212 E	P1.3 ■ 242 E	P2.1 ■ 163 E	P2.2 ■ 143 E	P2.3 ■ 127 E	P3.1 ■ 146 E	P3.2 ■ 118 E	P3.3 ■ 99 E	P4.1 ■ 87 E	P4.2 ■ 74 E	P4.3 ■ 61 E	M1.1 ■ 69 E	M1.2 ■ 58 E
M2.1 ■ 61 E	M2.2 ■ 50 E	M2.3 ■ 42 E	M3.1 ■ 52 D	M3.2 ■ 44 D	M3.3 ■ 40 D	M4.1 ■ 33 D	M4.2 ▣ 29 D	K1.1 ■ 143 E	K1.2 ■ 106 E	K1.3 ■ 80 E	K2.1 ■ 136 E	K2.2 ■ 110 E	K2.3 ■ 88 E
K3.1 ■ 120 E	K3.2 ■ 91 E	K3.3 ■ 74 E	K4.1 ■ 111 D	K4.2 ■ 84 D	K4.3 ■ 62 D	K4.4 ■ 53 D	K4.5 ■ 44 D	K5.1 ■ 126 E	K5.2 ■ 95 E	K5.3 ■ 73 E	N1.1 ■ 440 F	N1.2 ■ 330 F	N1.3 ■ 220 F
N2.1 ■ 288 F	N2.2 ■ 259 F	N2.3 ■ 187 F	N3.1 ■ 671 F	N3.2 ■ 396 F	N3.3 ■ 198 F	N4.1 ■ 319 F	N4.2 ■ 160 F	N4.3 ■ 72 F	S1.1 ■ 44 D	S1.2 ■ 44 D	S1.3 ▣ 33 D	S2.1 ■ 36 D	S2.2 ▣ 28 D
S3.1 ■ 28 D	S3.2 ▣ 23 D	S4.1 ■ 22 D	S4.2 ▣ 18 D	H1.1 ■ 66 D	H3.1 ▣ 48 D								

Filetage intérieur.

Product	TDZ	TP	DC	APMX	OAL	DCON MS	NOF
		(mm)	(mm)	(mm)	(mm)	(mm)	
J22510.0X1.5	M12	1.50	10.00	20.00	72.0	10.00	4
J22512.0X1.0	M14	1.00	12.00	22.00	83.0	12.00	4
J22514.0X1.5	M16	1.50	14.00	26.00	83.0	14.00	5
J22516.0X1.5	M18	1.50	16.00	30.00	92.0	16.00	5

J235



Fraise à fileter en carbure monobloc, arrosage centralisé, profil UNC

Outil universel haute performance permettant d'usinier des diamètres identiques ou supérieurs à la taille de filet indiquée (TDZ) avec le même pas. A gauche ou à droite, trous débouchants ou borgnes presque jusqu'au fond. Avec revêtement Alcrona Pro et arrosage centralisé pour une meilleure évacuation des copeaux et un résultat d'usinage optimal dans une large gamme de matériaux

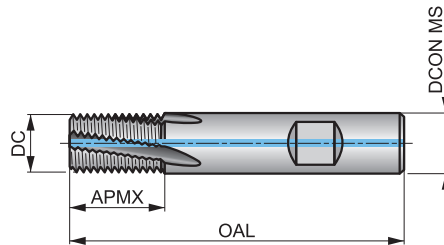

Adéquation du groupe de matériaux de la pièce, valeurs de départ pour la vitesse de coupe (m/min) et code alpha. Tableaux d'avances par dent et facteurs de correction à partir de la page 266.

P1.1 ■ 181 H	P1.2 ■ 203 H	P1.3 ■ 210 H	P2.1 ■ 156 H	P2.2 ■ 137 H	P2.3 ■ 121 H	P3.1 ■ 140 H	P3.2 ■ 112 H	P3.3 ■ 95 H	P4.1 ■ 83 H	P4.2 ■ 70 H	P4.3 ■ 58 H	M1.1 ■ 65 H	M1.2 ■ 55 H
M2.1 ■ 58 H	M2.2 ■ 47 H	M2.3 ■ 40 H	M3.1 ■ 50 G	M3.2 ■ 42 G	M3.3 ■ 38 G	M4.1 ■ 32 G	M4.2 ▣ 27 G	K1.1 ■ 137 H	K1.2 ■ 101 H	K1.3 ■ 76 H	K2.1 ■ 129 H	K2.2 ■ 105 H	K2.3 ■ 84 H
K3.1 ■ 115 H	K3.2 ■ 87 H	K3.3 ■ 71 H	K4.1 ■ 106 G	K4.2 ■ 80 G	K4.3 ■ 59 G	K4.4 ■ 51 G	K4.5 ■ 42 G	K5.1 ■ 120 H	K5.2 ■ 90 H	K5.3 ■ 70 H	N1.1 ■ 420 I	N1.2 ■ 315 I	N1.3 ■ 210 I
N2.1 ■ 275 I	N2.2 ■ 247 I	N2.3 ■ 179 I	N3.1 ■ 640 I	N3.2 ■ 378 I	N3.3 ■ 189 I	N4.1 ■ 305 I	N4.2 ■ 153 I	N4.3 ■ 69 I	S1.1 ■ 42 G	S1.2 ■ 42 G	S1.3 ▣ 32 G	S2.1 ■ 35 G	S2.2 ▣ 26 G
S3.1 ■ 26 G	S3.2 ▣ 22 G	S4.1 ■ 21 G	S4.2 ▣ 17 G	H1.1 ■ 63 G	H3.1 ▣ 45 G								

Filetage intérieur.

Product	TDZ	TPI	DC	APMX	OAL	DCON MS	NOF
			(mm)	(mm)	(mm)	(mm)	
J2354.8-20	1/4	20	4.80	14.00	57.0	6.00	3
J2355.5-18	5/16	18	5.50	14.00	57.0	6.00	3
J2357.5-16	3/8	16	7.50	19.00	63.0	8.00	4
J2358.0-14	7/16	14	8.00	19.00	63.0	8.00	4
J23510.0-13	1/2	13	10.00	22.00	72.0	10.00	4
J23510.0-12	9/16	12	10.00	22.00	72.0	10.00	4
J23512.0-11	5/8	11	12.00	26.00	83.0	12.00	4
J23514.0-10	3/4	10	14.00	32.00	83.0	14.00	5

J245

DORMER



Fraise à fileter en carbure monobloc, arrosage centralisé, profil UNF

Outil universel haute performance permettant d'usinier des diamètres identiques ou supérieurs à la taille de filet indiquée (TDZ) avec le même pas. A gauche ou à droite, trous débouchants ou borgnes presque jusqu'au fond. Avec revêtement Alcrona Pro et arrosage centralisé pour une meilleure évacuation des copeaux et un résultat d'usinage optimal dans une large gamme de matériaux

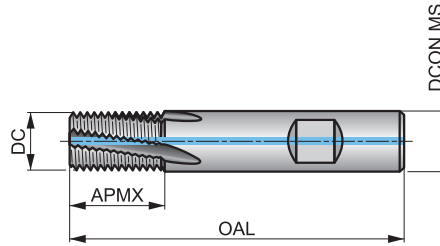

Adéquation du groupe de matériaux de la pièce, valeurs de départ pour la vitesse de coupe (m/min) et code alpha. Tableaux d'avances par dent et facteurs de correction à partir de la page 266.

P1.1 ■ 181 K	P1.2 ■ 203 K	P1.3 ■ 210 K	P2.1 ■ 156 K	P2.2 ■ 137 K	P2.3 ■ 121 K	P3.1 ■ 140 K	P3.2 ■ 112 K	P3.3 ■ 95 K	P4.1 ■ 83 K	P4.2 ■ 70 K	P4.3 ■ 58 K	M1.1 ■ 65 K	M1.2 ■ 55 K
M2.1 ■ 58 K	M2.2 ■ 47 K	M2.3 ■ 40 K	M3.1 ■ 50 J	M3.2 ■ 42 J	M3.3 ■ 38 J	M4.1 ■ 32 J	M4.2 ▣ 27 J	K1.1 ■ 137 K	K1.2 ■ 101 K	K1.3 ■ 76 K	K2.1 ■ 129 K	K2.2 ■ 105 K	K2.3 ■ 84 K
K3.1 ■ 115 K	K3.2 ■ 87 K	K3.3 ■ 71 K	K4.1 ■ 106 J	K4.2 ■ 80 J	K4.3 ■ 59 J	K4.4 ■ 51 J	K4.5 ■ 42 J	K5.1 ■ 120 K	K5.2 ■ 90 K	K5.3 ■ 70 K	N1.1 ■ 420 L	N1.2 ■ 315 L	N1.3 ■ 210 L
N2.1 ■ 275 L	N2.2 ■ 247 L	N2.3 ■ 179 L	N3.1 ■ 640 L	N3.2 ■ 378 L	N3.3 ■ 189 L	N4.1 ■ 305 L	N4.2 ■ 153 L	N4.3 ■ 69 L	S1.1 ■ 42 J	S1.2 ■ 42 J	S1.3 ▣ 32 J	S2.1 ■ 35 J	S2.2 ▣ 26 J
S3.1 ■ 26 J	S3.2 ▣ 22 J	S4.1 ■ 21 J	S4.2 ▣ 17 J	H1.1 ■ 63 J	H3.1 ▣ 45 J								

Filetage intérieur.

Product	TDZ	TPI	DC	APMX	OAL	DCON MS	NOF
			(mm)	(mm)	(mm)	(mm)	
J2454.8-28	1/4	28	4.80	14.00	57.0	6.00	3
J2456.0-24	5/16, 3/8	24	6.00	14.00	57.0	6.00	3
J2458.0-20	7/16, 1/2	20	8.00	19.00	63.0	8.00	4
J24510.0-18	9/16, 5/8	18	10.00	22.00	72.0	10.00	4
J24514.0-16	3/4	16	14.00	32.00	83.0	14.00	5

J260



Fraise à fileter en Carbure Monobloc, angle d'hélice à 10°, profil NPT

Outil universel haute performance permettant d'usinier des diamètres identiques ou supérieurs à la taille de filet indiquée (TDZ) avec le même pas. A gauche ou à droite, trous débouchants ou borgnes presque jusqu'au fond. Avec revêtement Alcrona Pro pour un résultat d'usinage optimal dans une large gamme de matériaux.

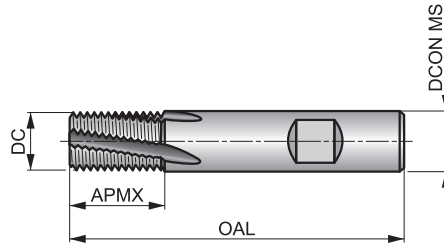

Adéquation du groupe de matériaux de la pièce, valeurs de départ pour la vitesse de coupe (m/min) et code alpha. Tableaux d'avances par dent et facteurs de correction à partir de la page 266.

P1.1 ■ 190 R	P1.2 ■ 212 R	P1.3 ■ 242 R	P2.1 ■ 163 R	P2.2 ■ 143 R	P2.3 ■ 127 R	P3.1 ■ 146 R	P3.2 ■ 118 R	P3.3 ■ 99 R	P4.1 ■ 87 R	P4.2 ■ 74 R	P4.3 ■ 61 R	M1.1 ■ 69 R	M1.2 ■ 58 R
M2.1 ■ 61 R	M2.2 ■ 50 R	M2.3 ■ 42 R	M3.1 ■ 52 Q	M3.2 ■ 44 Q	M3.3 ■ 40 Q	M4.1 ■ 33 Q	M4.2 ▣ 29 Q	K1.1 ■ 143 R	K1.2 ■ 106 R	K1.3 ■ 80 R	K2.1 ■ 136 R	K2.2 ■ 110 R	K2.3 ■ 88 R
K3.1 ■ 120 R	K3.2 ■ 91 R	K3.3 ■ 74 R	K4.1 ■ 111 Q	K4.2 ■ 84 Q	K4.3 ■ 62 Q	K4.4 ■ 53 Q	K4.5 ■ 44 Q	K5.1 ■ 126 R	K5.2 ■ 95 R	K5.3 ■ 73 R	N1.1 ■ 440 S	N1.2 ■ 330 S	N1.3 ■ 220 S
N2.1 ■ 288 S	N2.2 ■ 259 S	N2.3 ■ 187 S	N3.1 ■ 671 S	N3.2 ■ 396 S	N3.3 ■ 198 S	N4.1 ■ 319 S	N4.2 ■ 160 S	N4.3 ■ 72 S	S1.1 ■ 44 Q	S1.2 ■ 44 Q	S1.3 ▣ 33 Q	S2.1 ■ 36 Q	S2.2 ▣ 28 Q
S3.1 ■ 28 Q	S3.2 ▣ 23 Q	S4.1 ■ 22 Q	S4.2 ▣ 18 Q	H1.1 ■ 66 Q	H3.1 ▣ 48 Q								

Filetage intérieur.

Product	TDZ	TPI	DC	APMX	OAL	DCON MS	NOF
			(mm)	(mm)	(mm)	(mm)	
J2607.9-27	1/8	27	7.90	11.50	58.0	8.00	3
J2609.9-18	1/4, 3/8	18	9.90	15.92	66.0	10.00	3
J26015.9-14	1/2, 3/4	14	15.90	20.46	82.0	16.00	4
J26019.9-11.5	1", 2"	11.5	19.90	27.12	92.0	20.00	5

J280



Fraise à fileter en Carbure Monobloc, angle d'hélice à 10°, profil G(BSP)

Outil universel haute performance permettant d'usinier des diamètres identiques ou supérieurs à la taille de filet indiquée (TDZ) avec le même pas. A gauche ou à droite, trous débouchants ou borgnes presque jusqu'au fond. Avec revêtement Alcrona Pro pour un résultat d'usinage optimal dans une large gamme de matériaux. Adapté à la réalisation de filetages intérieurs et extérieurs.

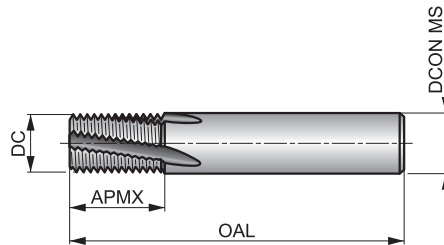

		1.5xD
HM		λ 10°
		DIN 6535HA

Adéquation du groupe de matériaux de la pièce, valeurs de départ pour la vitesse de coupe (m/min) et code alpha. Tableaux d'avances par dent et facteurs de correction à partir de la page 266.

P1.1 ■ 190 N	P1.2 ■ 212 N	P1.3 ■ 242 N	P2.1 ■ 163 N	P2.2 ■ 143 N	P2.3 ■ 127 N	P3.1 ■ 146 N	P3.2 ■ 118 N	P3.3 ■ 99 N	P4.1 ■ 87 N	P4.2 ■ 74 N	P4.3 ■ 61 N	M1.1 ■ 69 N	M1.2 ■ 58 N
M2.1 ■ 61 N	M2.2 ■ 50 N	M2.3 ■ 42 N	M3.1 ■ 52 M	M3.2 ■ 44 M	M3.3 ■ 40 M	M4.1 ■ 33 M	M4.2 □ 29 M	K1.1 ■ 143 N	K1.2 ■ 106 N	K1.3 ■ 80 N	K2.1 ■ 136 N	K2.2 ■ 110 N	K2.3 ■ 88 N
K3.1 ■ 120 N	K3.2 ■ 91 N	K3.3 ■ 74 N	K4.1 ■ 111 M	K4.2 ■ 84 M	K4.3 ■ 62 M	K4.4 ■ 53 M	K4.5 ■ 44 M	K5.1 ■ 126 N	K5.2 ■ 95 N	K5.3 ■ 76 N	N1.1 ■ 440 O	N1.2 ■ 330 O	N1.3 ■ 220 O
N2.1 ■ 288 O	N2.2 ■ 259 O	N2.3 ■ 187 O	N3.1 ■ 671 O	N3.2 ■ 396 O	N3.3 ■ 198 O	N4.1 ■ 319 O	N4.2 ■ 160 O	N4.3 ■ 72 O	S1.1 ■ 44 M	S1.2 ■ 44 M	S1.3 □ 33 M	S2.1 ■ 36 M	S2.2 □ 28 M
S3.1 ■ 28 M	S3.2 □ 23 M	S4.1 ■ 22 M	S4.2 □ 18 M	H1.1 ■ 66 M	H3.1 □ 48 M								

Filetage intérieur et extérieur.

Product	TDZ	TPI	DC	APMX	OAL	DCON MS	NOF
			(mm)	(mm)	(mm)	(mm)	
J2806.0-28	1/8	28	6.00	15.00	57.0	6.00	3
J28010.0-19	1/4	19	10.00	20.00	72.0	10.00	4
J28014.0-19	3/8	19	14.00	26.00	83.0	14.00	5
J28016.0-14	1/2, 5/8	14	16.00	30.00	92.0	16.00	5
J28020.0-14	5/8, 3/4, 7/8	14	20.00	35.00	104.0	20.00	5
J28025.0-11	1", 3"	11	25.00	45.00	121.0	25.00	6



FRAISES LIMES

Code de matériau du corps (BMC)	HM	HM	HM	HM	HM	HM	HM	HM	HM	HM	HM	HM	HM
	Code du type de fraise lime (BTC)	DC	DC	DC	DC	DC	DC	DC	DC	DC	DC	DC	DC
Forme de fraise lime													
Revêtement	Bright	TiAlN	Bright	TiAlN	Bright	TiAlN	Bright	TiAlN	Bright	Bright	TiAlN	Bright	TiAlN
Groupe standard de base (BSG)													
Angle d'application													
Géométrie en bout d'une fraise lime													
Code de famille de produits	P801	P801C	P803	P803C	P805	P805C	P807	P807C	P809	P811	P811C	P813	P813C
Plage de diamètres de coupe PSF	3.00 – 16.00	3.00 – 12.70	3.00 – 16.00	3.00 – 12.70	3.00 – 16.00	3.00 – 12.70	3.00 – 16.00	3.00 – 12.70	3.00 – 16.00	3.00 – 16.00	3.00 – 12.70	3.00 – 16.00	3.00 – 12.70
P	P1	■	■	■	■	■	■	■	■	■	■	■	■
	P2	■	■	■	■	■	■	■	■	■	■	■	■
	P3	■	■	■	■	■	■	■	■	■	■	■	■
	P4	■	■	■	■	■	■	■	■	■	■	■	■
M	M1	■	■	■	■	■	■	■	■	■	■	■	■
	M2	■	■	■	■	■	■	■	■	■	■	■	■
	M3	■	■	■	■	■	■	■	■	■	■	■	■
	M4	■	■	■	■	■	■	■	■	■	■	■	■
K	K1	■	■	■	■	■	■	■	■	■	■	■	■
	K2	■	■	■	■	■	■	■	■	■	■	■	■
	K3	■	■	■	■	■	■	■	■	■	■	■	■
	K4	■	■	■	■	■	■	■	■	■	■	■	■
	K5	■	■	■	■	■	■	■	■	■	■	■	■
N	N1												
	N2												
	N3	■	■	■	■	■	■	■	■	■	■	■	■
	N4												
	N5												
S	S1	■	■	■	■	■	■	■	■	■	■	■	■
	S2	■	■	■	■	■	■	■	■	■	■	■	■
	S3	■	■	■	■	■	■	■	■	■	■	■	■
	S4	■	■	■	■	■	■	■	■	■	■	■	■
H	H1	■	■	■	■	■	■	■	■	■	■	■	■
	H2	■	■	■	■	■	■	■	■	■	■	■	■
	H3	■	■	■	■	■	■	■	■	■	■	■	■
	H4	■	■	■	■	■	■	■	■	■	■	■	■

Utilisation principale
 Utilisation possible

ISO
13399PMK
NSH

	HM DC H Bright DORMER	HM DC H TiAlN DORMER	HM DC J Bright DORMER 60°	HM DC K Bright DORMER 90°	HM DC L Bright DORMER	HM DC L TiAlN DORMER	HM DC M Bright DORMER	HM DC N Bright DORMER										
	P815	P815C	P817	P819	P821	P821C	P823	P825										
	3.00 – 16.00	8.00 – 12.70	3.00 – 16.00	3.00 – 16.00	3.00 – 16.00	3.00 – 12.70	3.00 – 16.00	3.00 – 16.00										
	195	196	197	198	199	200	201	202										
P1	■	■	■	■	■	■	■	■										
P2	■	■	■	■	■	■	■	■										
P3	■	■	■	■	■	■	■	■										
P4	■	■	■	■	■	■	■	■										
M1	■	■	■	■	■	■	■	■										
M2	■	■	■	■	■	■	■	■										
M3	■	■	■	■	■	■	■	■										
M4	■	■	■	■	■	■	■	■										
K1	■	■	■	■	■	■	■	■										
K2	■	■	■	■	■	■	■	■										
K3	■	■	■	■	■	■	■	■										
K4	■	■	■	■	■	■	■	■										
K5	■	■	■	■	■	■	■	■										
N1																		
N2																		
N3	■	■	■	■	■	■	■	■										
N4																		
N5																		
S1	■	■	■	■	■	■	■	■										
S2	■	■	■	■	■	■	■	■										
S3	■	■	■	■	■	■	■	■										
S4	■	■	■	■	■	■	■	■										
H1	■	■	■	■	■	■	■	■										
H2	■	■	■	■	■	■	■	■										
H3	■	■	■	■	■	■	■	■										
H4	■	■	■	■	■	■	■	■										

■ Utilisation principale □ Utilisation possible

P801



Fraise lime rotative – Cylindrique sans coupe en bout, forme A, finition brillante

Denture double type DC avec goujures rapprochées. Convient pour tailler et ébavurer des surfaces. Conception en carbure monobloc pour les Ø de coupe jusqu'à 6 mm et tête en carbure brasée sur une queue en acier trempé et durci au-dessus de Ø6 mm.

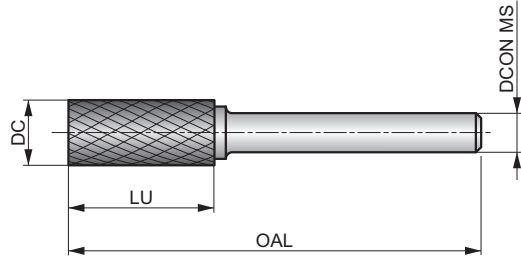

HM		Bright
DC		

Adéquation du groupe de matériaux de la pièce. Vitesse de fonctionnement recommandée (RPM) à la page 277.

P1.1	P1.2	P1.3	P2.1	P2.2	P2.3	P3.1	P3.2	P3.3	P4.1	P4.2	P4.3	M1.1	M1.2
M2.1	M2.2	M2.3	M3.1	M3.2	M3.3	M4.1	M4.2	K1.1	K1.2	K1.3	K2.1	K2.2	K2.3
K3.1	K3.2	K3.3	K4.1	K4.2	K4.3	K4.4	K4.5	K5.1	K5.2	K5.3	N3.1	N3.2	N3.3
S1.1	S1.2	S1.3	S2.1	S2.2	S3.1	S3.2	S4.1	S4.2	H1.1	H2.1	H2.2	H3.1	H3.2
H4.1	H4.2												

DC ≤ 6.00 mm: DCON MS tolérance h6; DC > 6.00 mm: brasé sur queue acier avec DCON MS tolérance h7.
Les produits de cette série sont également disponibles en coffret. Voir P880.

Product	DC (mm)	DCON MS (mm)	LU (mm)	OAL (mm)
P8013.0X3.0	3.00	3.00	14.00	38.0
P8016.3X3.0 ¹⁾	6.30	3.00	12.70	45.0
P8016.0X6.0	6.00	6.00	18.00	50.0
P8018.0X6.0 ¹⁾	8.00	6.00	19.00	64.0
P8019.6X6.0 ¹⁾	9.60	6.00	19.00	64.0
P80112.7X6.0 ¹⁾	12.70	6.00	25.00	70.0
P80116.0X6.0 ¹⁾	16.00	6.00	25.00	70.0

¹⁾ Brazed on steel shank

P801C



Fraise lime rotative – Cylindrique sans coupe en bout, forme A, revêtement TiAlN

Denture double type DC avec goujures rapprochées. Convient pour tailler et ébavurer des surfaces. Conception en carbure monobloc pour les \varnothing de coupe jusqu'à 6 mm et tête en carbure brasée sur une queue en acier trempé et durci au-dessus de $\varnothing 6$ mm. Revêtement TiAlN pour une longue durée de vie, une friction réduite et une meilleure évacuation des copeaux.

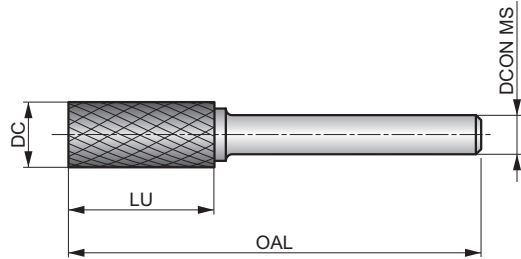

HM		
DC		

Adéquation du groupe de matériaux de la pièce. Vitesse de fonctionnement recommandée (RPM) à la page 277.

P1.1	P1.2	P1.3	P2.1	P2.2	P2.3	P3.1	P3.2	P3.3	P4.1	P4.2	P4.3	M1.1	M1.2
M2.1	M2.2	M2.3	M3.1	M3.2	M3.3	M4.1	M4.2	K1.1	K1.2	K1.3	K2.1	K2.2	K2.3
K3.1	K3.2	K3.3	K4.1	K4.2	K4.3	K4.4	K4.5	K5.1	K5.2	K5.3	N3.1	N3.2	N3.3
S1.1	S1.2	S1.3	S2.1	S2.2	S3.1	S3.2	S4.1	S4.2	H1.1	H2.1	H2.2	H3.1	H3.2
H4.1	H4.2												

DC ≤ 6.00 mm: DCON MS tolérance h6; DC > 6.00 mm: brasé sur queue acier avec DCON MS tolérance h7.

Product	DC (mm)	DCON MS (mm)	LU (mm)	OAL (mm)
P801C3.0X3.0	3.00	3.00	14.00	38.0
P801C6.0X6.0	6.00	6.00	18.00	50.0
P801C8.0X6.0 ¹⁾	8.00	6.00	19.00	64.0
P801C9.6X6.0 ¹⁾	9.60	6.00	19.00	64.0
P801C12.7X6.0 ¹⁾	12.70	6.00	25.00	70.0

¹⁾ Brazed on steel shank

P803



Fraise lime rotative – Cylindrique avec coupe en bout, forme B, finition brillante

Denture double type DC avec goujures rapprochées. Convient pour tailler et ébavurer des surfaces et des coins à angle droit. Conception en carbure monobloc pour les \varnothing de coupe jusqu'à 6 mm et tête en carbure brasée sur une queue en acier trempé et durci au-dessus de $\varnothing 6$ mm.

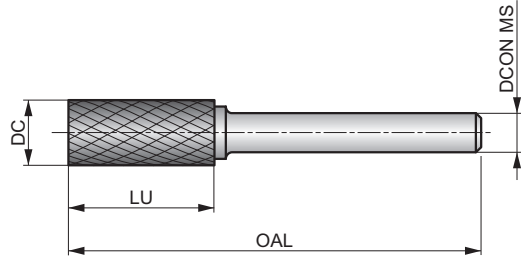

HM	B	
Bright	DC	DORMER



Adéquation du groupe de matériaux de la pièce. Vitesse de fonctionnement recommandée (RPM) à la page 277.

P1.1	P1.2	P1.3	P2.1	P2.2	P2.3	P3.1	P3.2	P3.3	P4.1	P4.2	P4.3	M1.1	M1.2
M2.1	M2.2	M2.3	M3.1	M3.2	M3.3	M4.1	M4.2	K1.1	K1.2	K1.3	K2.1	K2.2	K2.3
K3.1	K3.2	K3.3	K4.1	K4.2	K4.3	K4.4	K4.5	K5.1	K5.2	K5.3	N3.1	N3.2	N3.3
S1.1	S1.2	S1.3	S2.1	S2.2	S3.1	S3.2	S4.1	S4.2	H1.1	H2.1	H2.2	H3.1	H3.2
H4.1	H4.2												

DC ≤ 6.00 mm: DCON MS tolérance h6; DC > 6.00 mm: brasé sur queue acier avec DCON MS tolérance h7.
Les produits de cette série sont également disponibles en coffret. Voir P880 ou P890.

Product	DC (mm)	DCON MS (mm)	LU (mm)	OAL (mm)
P8033.0X3.0	3.00	3.00	14.00	38.0
P8036.3X3.0 ¹⁾	6.30	3.00	12.70	45.0
P8036.0X6.0	6.00	6.00	18.00	50.0
P8038.0X6.0 ¹⁾	8.00	6.00	19.00	64.0
P8039.6X6.0 ¹⁾	9.60	6.00	19.00	64.0
P80312.7X6.0 ¹⁾	12.70	6.00	25.00	70.0
P80316.0X6.0 ¹⁾	16.00	6.00	25.00	70.0

¹⁾ Brazed on steel shank

P803C



Fraise lime rotative – Cylindrique avec coupe en bout, forme B, revêtement TiAlN

Denture double type DC avec goujures rapprochées. Convient pour tailler et ébavurer des surfaces et des coins à angle droit. Conception en carbure monobloc pour les Ø de coupe jusqu'à 6 mm et tête en carbure brasée sur une queue en acier trempé et durci au-dessus de Ø6 mm. Revêtement TiAlN pour une longue durée de vie, une friction réduite et une meilleure évacuation des copeaux.

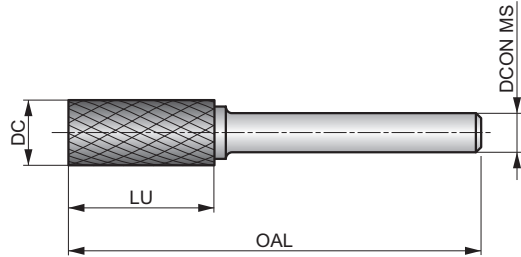

HM	B	
TiAlN	DC	DORMER



Adéquation du groupe de matériaux de la pièce. Vitesse de fonctionnement recommandée (RPM) à la page 277.

P1.1	P1.2	P1.3	P2.1	P2.2	P2.3	P3.1	P3.2	P3.3	P4.1	P4.2	P4.3	M1.1	M1.2
M2.1	M2.2	M2.3	M3.1	M3.2	M3.3	M4.1	M4.2	K1.1	K1.2	K1.3	K2.1	K2.2	K2.3
K3.1	K3.2	K3.3	K4.1	K4.2	K4.3	K4.4	K4.5	K5.1	K5.2	K5.3	N3.1	N3.2	N3.3
S1.1	S1.2	S1.3	S2.1	S2.2	S3.1	S3.2	S4.1	S4.2	H1.1	H2.1	H2.2	H3.1	H3.2
H4.1	H4.2												

DC ≤ 6.00 mm: DCON MS tolérance h6; DC > 6.00 mm: brasé sur queue acier avec DCON MS tolérance h7.
Les produits de cette série sont également disponibles en coffret. Voir P880.

Product	DC (mm)	DCON MS (mm)	LU (mm)	OAL (mm)
P803C3.0X3.0	3.00	3.00	14.00	38.0
P803C6.0X6.0	6.00	6.00	18.00	50.0
P803C8.0X6.0 ¹⁾	8.00	6.00	19.00	64.0
P803C9.6X6.0 ¹⁾	9.60	6.00	19.00	64.0
P803C12.7X6.0 ¹⁾	12.70	6.00	25.00	70.0

¹⁾ Brazed on steel shank

P805



Fraise lime rotative – Cylindrique à bout rond, forme C, finition brillante

Denture double type DC avec goujures rapprochées. Convient pour tailler et ébavurer des contours et des arcs circulaires. Conception en carbure monobloc pour les Ø de coupe jusqu'à 6 mm et tête en carbure brasée sur une queue en acier trempé et durci au-dessus de Ø6 mm.

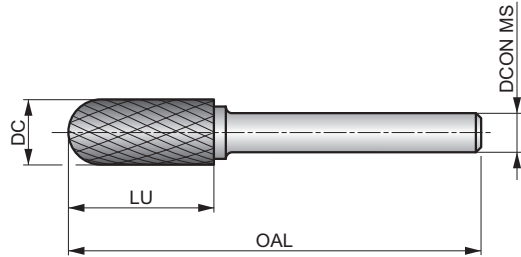

HM		Bright
DC		



Adéquation du groupe de matériaux de la pièce. Vitesse de fonctionnement recommandée (RPM) à la page 277.

P1.1	P1.2	P1.3	P2.1	P2.2	P2.3	P3.1	P3.2	P3.3	P4.1	P4.2	P4.3	M1.1	M1.2
M2.1	M2.2	M2.3	M3.1	M3.2	M3.3	M4.1	M4.2	K1.1	K1.2	K1.3	K2.1	K2.2	K2.3
K3.1	K3.2	K3.3	K4.1	K4.2	K4.3	K4.4	K4.5	K5.1	K5.2	K5.3	N3.1	N3.2	N3.3
S1.1	S1.2	S1.3	S2.1	S2.2	S3.1	S3.2	S4.1	S4.2	H1.1	H2.1	H2.2	H3.1	H3.2
H4.1	H4.2												

DC ≤ 6.00 mm: DCON MS tolérance h6; DC > 6.00 mm: brasé sur queue acier avec DCON MS tolérance h7.
Les produits de cette série sont également disponibles en coffret. Voir P880 ou P890.

Product	DC (mm)	DCON MS (mm)	LU (mm)	OAL (mm)
P8053.0X3.0	3.00	3.00	14.00	38.0
P8056.3X3.0 ¹⁾	6.30	3.00	12.70	45.0
P8056.0X6.0	6.00	6.00	18.00	50.0
P8058.0X6.0 ¹⁾	8.00	6.00	19.00	64.0
P8059.6X6.0 ¹⁾	9.60	6.00	19.00	64.0
P80512.7X6.0 ¹⁾	12.70	6.00	25.00	70.0
P80516.0X6.0 ¹⁾	16.00	6.00	25.00	70.0

¹⁾ Brazed on steel shank

P805C



Fraise lime rotative – Cylindrique à bout rond, forme C, revêtement TiAlN

Denture double type DC avec goujures rapprochées. Convient pour tailler et ébavurer des contours et des arcs circulaires. Conception en carbure monobloc pour les Ø de coupe jusqu'à 6 mm et tête en carbure brasée sur une queue en acier trempé et durci au-dessus de Ø6 mm. Revêtement TiAlN pour une longue durée de vie, une friction réduite et une meilleure évacuation des copeaux.

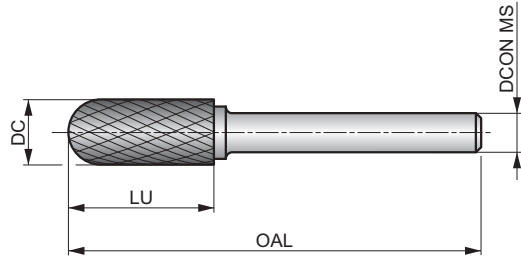

HM		
DC		



Adéquation du groupe de matériaux de la pièce. Vitesse de fonctionnement recommandée (RPM) à la page 277.

P1.1	P1.2	P1.3	P2.1	P2.2	P2.3	P3.1	P3.2	P3.3	P4.1	P4.2	P4.3	M1.1	M1.2
M2.1	M2.2	M2.3	M3.1	M3.2	M3.3	M4.1	M4.2	K1.1	K1.2	K1.3	K2.1	K2.2	K2.3
K3.1	K3.2	K3.3	K4.1	K4.2	K4.3	K4.4	K4.5	K5.1	K5.2	K5.3	N3.1	N3.2	N3.3
S1.1	S1.2	S1.3	S2.1	S2.2	S3.1	S3.2	S4.1	S4.2	H1.1	H2.1	H2.2	H3.1	H3.2
H4.1	H4.2												

DC ≤ 6.00 mm: DCON MS tolérance h6; DC > 6.00 mm: brasé sur queue acier avec DCON MS tolérance h7.
Les produits de cette série sont également disponibles en coffret. Voir P880.

Product	DC (mm)	DCON MS (mm)	LU (mm)	OAL (mm)
P805C3.0X3.0	3.00	3.00	14.00	38.0
P805C6.0X6.0	6.00	6.00	18.00	50.0
P805C8.0X6.0 ¹⁾	8.00	6.00	19.00	64.0
P805C9.6X6.0 ¹⁾	9.60	6.00	19.00	64.0
P805C12.7X6.0 ¹⁾	12.70	6.00	25.00	70.0

¹⁾ Brazed on steel shank

P807



Fraise lime rotative – Boule, forme D, finition brillante

Denture double type DC avec goujures rapprochées. Convient pour la sculpture de formes complexes, la gravure sur métal et la préparation de soudures. Conception en carbure monobloc pour les Ø de coupe jusqu'à 6 mm et tête en carbure brasée sur une queue en acier trempé et durci au-dessus de Ø6 mm.

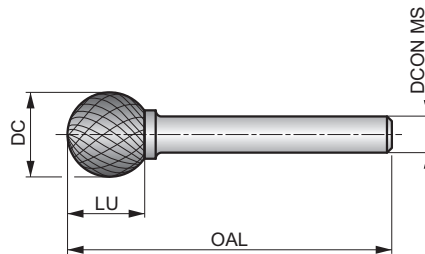

HM	
DC	



Adéquation du groupe de matériaux de la pièce. Vitesse de fonctionnement recommandée (RPM) à la page 277.

P1.1	P1.2	P1.3	P2.1	P2.2	P2.3	P3.1	P3.2	P3.3	P4.1	P4.2	P4.3	M1.1	M1.2
M2.1	M2.2	M2.3	M3.1	M3.2	M3.3	M4.1	M4.2	K1.1	K1.2	K1.3	K2.1	K2.2	K2.3
K3.1	K3.2	K3.3	K4.1	K4.2	K4.3	K4.4	K4.5	K5.1	K5.2	K5.3	N3.1	N3.2	N3.3
S1.1	S1.2	S1.3	S2.1	S2.2	S3.1	S3.2	S4.1	S4.2	H1.1	H2.1	H2.2	H3.1	H3.2
H4.1	H4.2												

DC ≤ 6.00 mm: DCON MS tolérance h6; DC > 6.00 mm: brasé sur queue acier avec DCON MS tolérance h7.
 Les produits de cette série sont également disponibles en coffret. Voir P880.

Product	DC (mm)	DCON MS (mm)	LU (mm)	OAL (mm)
P8073.0X3.0	3.00	3.00	2.50	38.0
P8074.0X3.0	4.00	3.00	3.40	38.0
P8076.3X3.0 ¹⁾	6.30	3.00	5.00	38.0
P8076.0X6.0	6.00	6.00	4.70	50.0
P8078.0X6.0 ¹⁾	8.00	6.00	6.00	52.0
P8079.6X6.0 ¹⁾	9.60	6.00	8.00	54.0
P80712.7X6.0 ¹⁾	12.70	6.00	11.00	56.0
P80716.0X6.0 ¹⁾	16.00	6.00	14.00	59.0

¹⁾ Brazed on steel shank

P807C



Fraise lime rotative – Boule, forme D, revêtement TiAlN

Denture double type DC avec goujures rapprochées. Convient pour la sculpture de formes complexes, la gravure sur métal et la préparation de soudures. Conception en carbure monobloc pour les Ø de coupe jusqu'à 6 mm et tête en carbure brasée sur une queue en acier trempé et durci au-dessus de Ø6 mm. Revêtement TiAlN pour une longue durée de vie, une friction réduite et une meilleure évacuation des copeaux.

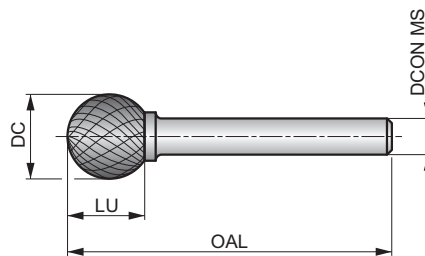

HM		
DC		



Adéquation du groupe de matériaux de la pièce. Vitesse de fonctionnement recommandée (RPM) à la page 277.

P1.1	P1.2	P1.3	P2.1	P2.2	P2.3	P3.1	P3.2	P3.3	P4.1	P4.2	P4.3	M1.1	M1.2
M2.1	M2.2	M2.3	M3.1	M3.2	M3.3	M4.1	M4.2	K1.1	K1.2	K1.3	K2.1	K2.2	K2.3
K3.1	K3.2	K3.3	K4.1	K4.2	K4.3	K4.4	K4.5	K5.1	K5.2	K5.3	N3.1	N3.2	N3.3
S1.1	S1.2	S1.3	S2.1	S2.2	S3.1	S3.2	S4.1	S4.2	H1.1	H2.1	H2.2	H3.1	H3.2
H4.1	H4.2												

DC ≤ 6.00 mm: DCON MS tolérance h6; DC > 6.00 mm: brasé sur queue acier avec DCON MS tolérance h7.
Les produits de cette série sont également disponibles en coffret. Voir P880.

Product	DC (mm)	DCON MS (mm)	LU (mm)	OAL (mm)
P807C3.0X3.0	3.00	3.00	2.50	38.0
P807C6.0X6.0	6.00	6.00	4.70	50.0
P807C8.0X6.0 ¹⁾	8.00	6.00	6.00	52.0
P807C9.6X6.0 ¹⁾	9.60	6.00	8.00	54.0
P807C12.7X6.0 ¹⁾	12.70	6.00	11.00	56.0

¹⁾ Brazed on steel shank

P809



Fraise lime rotative – Ovale, forme E

Denture double type DC avec goujures rapprochées. Convient pour le contournage des bords ronds. Conception en carbure monobloc pour les Ø de coupe jusqu'à 6 mm et tête en carbure brasée sur une queue en acier trempé et durci au-dessus de Ø6 mm.

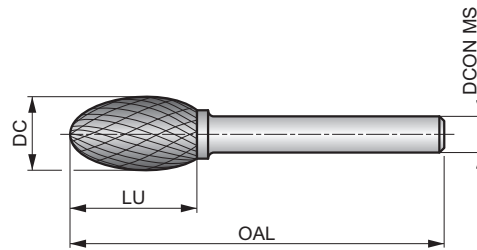

HM		Bright
DC		



Adéquation du groupe de matériaux de la pièce. Vitesse de fonctionnement recommandée (RPM) à la page 277.

P1.1	P1.2	P1.3	P2.1	P2.2	P2.3	P3.1	P3.2	P3.3	P4.1	P4.2	P4.3	M1.1	M1.2
M2.1	M2.2	M2.3	M3.1	M3.2	M3.3	M4.1	M4.2	K1.1	K1.2	K1.3	K2.1	K2.2	K2.3
K3.1	K3.2	K3.3	K4.1	K4.2	K4.3	K4.4	K4.5	K5.1	K5.2	K5.3	N3.1	N3.2	N3.3
S1.1	S1.2	S1.3	S2.1	S2.2	S3.1	S3.2	S4.1	S4.2	H1.1	H2.1	H2.2	H3.1	H3.2
H4.1	H4.2												

DC ≤ 6.00 mm: DCON MS tolérance h6; DC > 6.00 mm: brasé sur queue acier avec DCON MS tolérance h7.
Les produits de cette série sont également disponibles en coffret. Voir P880.

Product	DC (mm)	DCON MS (mm)	LU (mm)	OAL (mm)
P8093.0X3.0	3.00	3.00	6.00	38.0
P8096.3X3.0 ¹⁾	6.30	3.00	9.50	42.0
P8096.0X6.0	6.00	6.00	10.00	50.0
P8098.0X6.0 ¹⁾	8.00	6.00	15.00	60.0
P8099.6X6.0 ¹⁾	9.60	6.00	16.00	60.0
P80912.7X6.0 ¹⁾	12.70	6.00	22.00	67.0
P80916.0X6.0 ¹⁾	16.00	6.00	25.00	70.0

¹⁾ Brazed on steel shank

P811



Fraise lime rotative – Ogive à bout rond, forme F, finition brillante

Denture double type DC avec goujures rapprochées. Convient pour le contourage multi angle, arrondir des arêtes et pour la coupe dans les zones difficiles à atteindre. Conception en carbure monobloc pour les Ø de coupe jusqu'à 6 mm et tête en carbure brasée sur une queue en acier trempé et durci au-dessus de Ø6 mm.

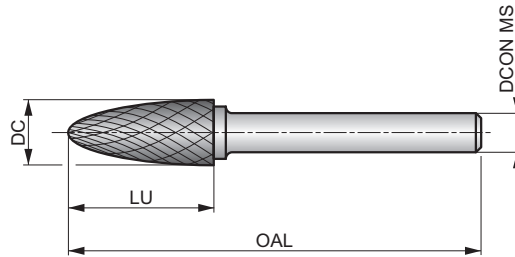

HM	F	Bright
DC		



Adéquation du groupe de matériaux de la pièce. Vitesse de fonctionnement recommandée (RPM) à la page 277.

P1.1	P1.2	P1.3	P2.1	P2.2	P2.3	P3.1	P3.2	P3.3	P4.1	P4.2	P4.3	M1.1	M1.2
M2.1	M2.2	M2.3	M3.1	M3.2	M3.3	M4.1	M4.2	K1.1	K1.2	K1.3	K2.1	K2.2	K2.3
K3.1	K3.2	K3.3	K4.1	K4.2	K4.3	K4.4	K4.5	K5.1	K5.2	K5.3	N3.1	N3.2	N3.3
S1.1	S1.2	S1.3	S2.1	S2.2	S3.1	S3.2	S4.1	S4.2	H1.1	H2.1	H2.2	H3.1	H3.2
H4.1	H4.2												

DC ≤ 6.00 mm: DCON MS tolérance h6; DC > 6.00 mm: brasé sur queue acier avec DCON MS tolérance h7.
Les produits de cette série sont également disponibles en coffret. Voir P880 ou P890.

Product	DC (mm)	DCON MS (mm)	LU (mm)	OAL (mm)
P8113.0X3.0	3.00	3.00	14.00	38.0
P8116.3X3.0 ¹⁾	6.30	3.00	12.70	45.0
P8116.0X6.0	6.00	6.00	18.00	50.0
P8118.0X6.0 ¹⁾	8.00	6.00	20.00	65.0
P8119.6X6.0 ¹⁾	9.60	6.00	19.00	64.0
P81112.7X6.0 ¹⁾	12.70	6.00	25.00	70.0
P81116.0X6.0 ¹⁾	16.00	6.00	25.00	70.0

¹⁾ Brazed on steel shank

P811C



Fraise lime rotative – Ogive à bout rond, forme F, revêtement TiAlN

Denture double type DC avec goujures rapprochées. Convient pour le contourage multi angle, l'arrondi d'arêtes et pour les zones difficiles à atteindre. Conception en carbure monobloc pour les Ø de coupe jusqu'à 6 mm et tête en carbure brasée sur une queue en acier trempé et durci au-dessus de Ø6 mm. Revêtement TiAlN pour une longue durée de vie, une friction réduite et une meilleure évacuation des copeaux.

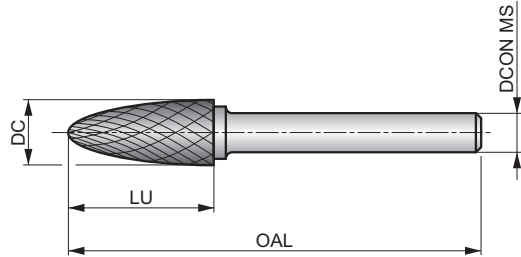

HM		
DC		



Adéquation du groupe de matériaux de la pièce. Vitesse de fonctionnement recommandée (RPM) à la page 277.

P1.1	P1.2	P1.3	P2.1	P2.2	P2.3	P3.1	P3.2	P3.3	P4.1	P4.2	P4.3	M1.1	M1.2
M2.1	M2.2	M2.3	M3.1	M3.2	M3.3	M4.1	M4.2	K1.1	K1.2	K1.3	K2.1	K2.2	K2.3
K3.1	K3.2	K3.3	K4.1	K4.2	K4.3	K4.4	K4.5	K5.1	K5.2	K5.3	N3.1	N3.2	N3.3
S1.1	S1.2	S1.3	S2.1	S2.2	S3.1	S3.2	S4.1	S4.2	H1.1	H2.1	H2.2	H3.1	H3.2
H4.1	H4.2												

DC ≤ 6.00 mm: DCON MS tolérance h6; DC > 6.00 mm: brasé sur queue acier avec DCON MS tolérance h7.
 Les produits de cette série sont également disponibles en coffret. Voir P880.

Product	DC (mm)	DCON MS (mm)	LU (mm)	OAL (mm)
P811C3.0X3.0	3.00	3.00	14.00	38.0
P811C6.0X6.0	6.00	6.00	18.00	50.0
P811C9.6X6.0 ¹⁾	9.60	6.00	19.00	64.0
P811C12.7X6.0 ¹⁾	12.70	6.00	25.00	70.0

¹⁾ Brazed on steel shank

P813



Fraise lime rotative – Ogive à bout pointu, forme G, finition brillante

Denture double type DC avec goujures rapprochées. Convient pour le contourage multi angle et la coupe d'angles étroits dans les zones difficiles à atteindre. Conception en carbure monobloc pour les Ø de coupe jusqu'à 6 mm et tête en carbure brasée sur une queue en acier trempé et durci au-dessus de Ø6 mm.

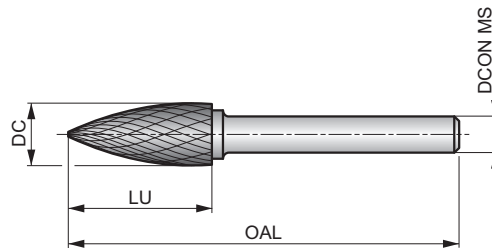

HM	
DC	



Adéquation du groupe de matériaux de la pièce. Vitesse de fonctionnement recommandée (RPM) à la page 277.

P1.1	P1.2	P1.3	P2.1	P2.2	P2.3	P3.1	P3.2	P3.3	P4.1	P4.2	P4.3	M1.1	M1.2
M2.1	M2.2	M2.3	M3.1	M3.2	M3.3	M4.1	M4.2	K1.1	K1.2	K1.3	K2.1	K2.2	K2.3
K3.1	K3.2	K3.3	K4.1	K4.2	K4.3	K4.4	K4.5	K5.1	K5.2	K5.3	N3.1	N3.2	N3.3
S1.1	S1.2	S1.3	S2.1	S2.2	S3.1	S3.2	S4.1	S4.2	H1.1	H2.1	H2.2	H3.1	H3.2
H4.1	H4.2												

DC ≤ 6.00 mm: DCON MS tolérance h6; DC > 6.00 mm: brasé sur queue acier avec DCON MS tolérance h7.
 Les produits de cette série sont également disponibles en coffret. Voir P880 ou P890.

Product	DC (mm)	DCON MS (mm)	LU (mm)	OAL (mm)
P8133.0X3.0	3.00	3.00	14.00	38.0
P8136.3X3.0 ¹⁾	6.30	3.00	12.70	45.0
P8136.0X6.0	6.00	6.00	18.00	50.0
P8138.0X6.0 ¹⁾	8.00	6.00	19.00	64.0
P8139.6X6.0 ¹⁾	9.60	6.00	19.00	64.0
P81312.7X6.0 ¹⁾	12.70	6.00	25.00	70.0
P81316.0X6.0 ¹⁾	16.00	6.00	25.00	70.0

¹⁾ Brazed on steel shank

P813C



Fraise lime rotative – Ogive à bout pointu, forme G, revêtement TiAlN

Denture double type DC avec goujures rapprochées. Convient pour le contourage multi angle et la coupe d'angles étroits dans les zones difficiles à atteindre. Conception en carbure monobloc pour les Ø de coupe jusqu'à 6 mm et tête en carbure brasée sur une queue en acier trempé et durci au-dessus de Ø6 mm. Revêtement TiAlN pour une longue durée de vie, une friction réduite et une meilleure évacuation des copeaux.

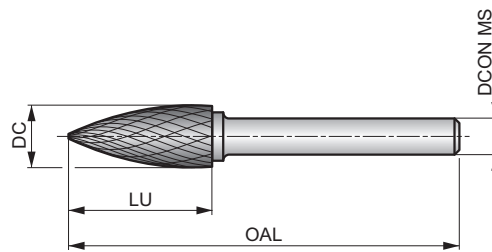

HM		
DC		



Adéquation du groupe de matériaux de la pièce. Vitesse de fonctionnement recommandée (RPM) à la page 277.

P1.1	P1.2	P1.3	P2.1	P2.2	P2.3	P3.1	P3.2	P3.3	P4.1	P4.2	P4.3	M1.1	M1.2
M2.1	M2.2	M2.3	M3.1	M3.2	M3.3	M4.1	M4.2	K1.1	K1.2	K1.3	K2.1	K2.2	K2.3
K3.1	K3.2	K3.3	K4.1	K4.2	K4.3	K4.4	K4.5	K5.1	K5.2	K5.3	N3.1	N3.2	N3.3
S1.1	S1.2	S1.3	S2.1	S2.2	S3.1	S3.2	S4.1	S4.2	H1.1	H2.1	H2.2	H3.1	H3.2
H4.1	H4.2												

DC ≤ 6.00 mm: DCON MS tolérance h6; DC > 6.00 mm: brasé sur queue acier avec DCON MS tolérance h7.
Les produits de cette série sont également disponibles en coffret. Voir P880.

Product	DC (mm)	DCON MS (mm)	LU (mm)	OAL (mm)
P813C3.0X3.0	3.00	3.00	14.00	38.0
P813C6.0X6.0	6.00	6.00	18.00	50.0
P813C9.6X6.0 ¹⁾	9.60	6.00	19.00	64.0
P813C12.7X6.0 ¹⁾	12.70	6.00	25.00	70.0

¹⁾ Brazed on steel shank

P815



Fraise lime rotative – Flamme, forme H, finition brillante

Denture double type DC avec goujures rapprochées. Convient pour le contournage des bords ronds et la préparation de soudures. Conception en carbure monobloc pour les Ø de coupe jusqu'à 6 mm et tête en carbure brasée sur une queue en acier trempé et durci au-dessus de Ø6 mm.

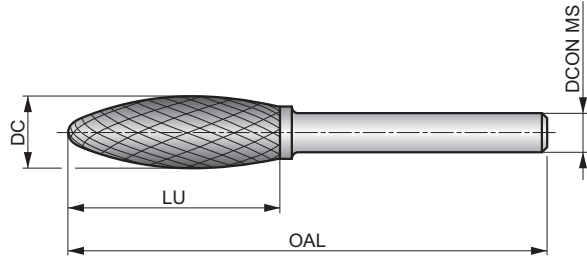

HM		Bright
DC		



Adéquation du groupe de matériaux de la pièce. Vitesse de fonctionnement recommandée (RPM) à la page 277.

P1.1	P1.2	P1.3	P2.1	P2.2	P2.3	P3.1	P3.2	P3.3	P4.1	P4.2	P4.3	M1.1	M1.2
M2.1	M2.2	M2.3	M3.1	M3.2	M3.3	M4.1	M4.2	K1.1	K1.2	K1.3	K2.1	K2.2	K2.3
K3.1	K3.2	K3.3	K4.1	K4.2	K4.3	K4.4	K4.5	K5.1	K5.2	K5.3	N3.1	N3.2	N3.3
S1.1	S1.2	S1.3	S2.1	S2.2	S3.1	S3.2	S4.1	S4.2	H1.1	H2.1	H2.2	H3.1	H3.2
H4.1	H4.2												

DC ≤ 6.00 mm: DCON MS tolérance h6; DC > 6.00 mm: brasé sur queue acier avec DCON MS tolérance h7.
 Les produits de cette série sont également disponibles en coffret. Voir P880.

Product	DC (mm)	DCON MS (mm)	LU (mm)	OAL (mm)
P8153.0X3.0	3.00	3.00	6.00	38.0
P8156.0X6.0	6.00	6.00	14.00	50.0
P8158.0X6.0 ¹⁾	8.00	6.00	19.00	64.0
P8159.6X6.0 ¹⁾	9.60	6.00	19.00	65.0
P81512.7X6.0 ¹⁾	12.70	6.00	32.00	77.0
P81516.0X6.0 ¹⁾	16.00	6.00	36.00	81.0

¹⁾ Brazed on steel shank

P815C



Fraise lime rotative – Flamme, forme H, revêtement TiAlN

Denture double type DC avec goujures rapprochées. Convient pour le contournage des bords ronds et la préparation de soudures. Conception en carbure monobloc pour les Ø de coupe jusqu'à 6 mm et tête en carbure brasée sur une queue en acier trempé et durci au-dessus de Ø6 mm. Revêtement TiAlN pour une longue durée de vie, une friction réduite et une meilleure évacuation des copeaux.

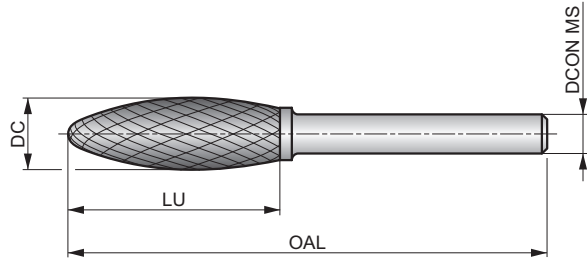

HM	H	TiAlN
DC	DORMER	



Adéquation du groupe de matériaux de la pièce. Vitesse de fonctionnement recommandée (RPM) à la page 277.

P1.1	P1.2	P1.3	P2.1	P2.2	P2.3	P3.1	P3.2	P3.3	P4.1	P4.2	P4.3	M1.1	M1.2
M2.1	M2.2	M2.3	M3.1	M3.2	M3.3	M4.1	M4.2	K1.1	K1.2	K1.3	K2.1	K2.2	K2.3
K3.1	K3.2	K3.3	K4.1	K4.2	K4.3	K4.4	K4.5	K5.1	K5.2	K5.3	N3.1	N3.2	N3.3
S1.1	S1.2	S1.3	S2.1	S2.2	S3.1	S3.2	S4.1	S4.2	H1.1	H2.1	H2.2	H3.1	H3.2
H4.1	H4.2												

Brasé sur queue acier avec DCON MS tolérance h7.

Product	DC (mm)	DCON MS (mm)	LU (mm)	OAL (mm)
P815C8.0X6.0 ¹⁾	8.00	6.00	19.00	64.0
P815C12.7X6.0 ¹⁾	12.70	6.00	32.00	77.0

¹⁾ Brazed on steel shank

P817



Fraise lime rotative – Fraise à 60°, forme J

Denture double type DC avec goujures rapprochées. Convient pour le chanfreinage, les coupes en V et la préparation de soudures. Conception en carbure monobloc pour les Ø de coupe jusqu'à 6 mm et tête en carbure brasée sur une queue en acier trempé et durci au-dessus de Ø6 mm.

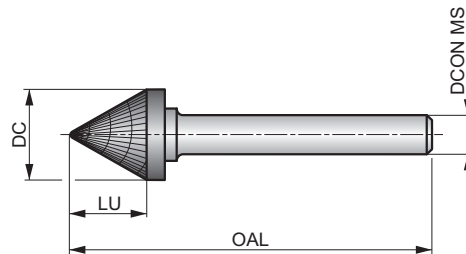

HM	J	Bright
60°	DC	DORMER



Adéquation du groupe de matériaux de la pièce. Vitesse de fonctionnement recommandée (RPM) à la page 277.

P1.1	P1.2	P1.3	P2.1	P2.2	P2.3	P3.1	P3.2	P3.3	P4.1	P4.2	P4.3	M1.1	M1.2
M2.1	M2.2	M2.3	M3.1	M3.2	M3.3	M4.1	M4.2	K1.1	K1.2	K1.3	K2.1	K2.2	K2.3
K3.1	K3.2	K3.3	K4.1	K4.2	K4.3	K4.4	K4.5	K5.1	K5.2	K5.3	N3.1	N3.2	N3.3
S1.1	S1.2	S1.3	S2.1	S2.2	S3.1	S3.2	S4.1	S4.2	H1.1	H2.1	H2.2	H3.1	H3.2
H4.1	H4.2												

DC ≤ 6.00 mm: DCON MS tolérance h6; DC > 6.00 mm: brasé sur queue acier avec DCON MS tolérance h7.

Product	DC (mm)	DCON MS (mm)	LU (mm)	OAL (mm)
P8173.0X3.0	3.00	3.00	2.50	38.0
P8176.0X6.0	6.00	6.00	4.00	50.0
P8179.6X6.0 ¹⁾	9.60	6.00	8.00	56.0
P81712.7X6.0 ¹⁾	12.70	6.00	11.00	59.0
P81716.0X6.0 ¹⁾	16.00	6.00	14.50	63.0

¹⁾ Brazed on steel shank

P819



Fraise lime rotative – Fraise à 90°, forme K

Denture double type DC avec goujures rapprochées. Convient pour le chanfreinage, les coupes en V et la préparation de soudures. Conception en carbure monobloc pour les Ø de coupe jusqu'à 6 mm et tête en carbure brasée sur une queue en acier trempé et durci au-dessus de Ø6 mm.

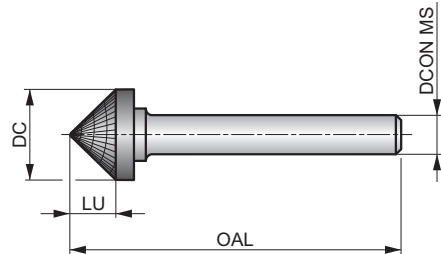

HM	K	Bright
90°	DC	DORMER



Adéquation du groupe de matériaux de la pièce. Vitesse de fonctionnement recommandée (RPM) à la page 277.

P1.1	P1.2	P1.3	P2.1	P2.2	P2.3	P3.1	P3.2	P3.3	P4.1	P4.2	P4.3	M1.1	M1.2
M2.1	M2.2	M2.3	M3.1	M3.2	M3.3	M4.1	M4.2	K1.1	K1.2	K1.3	K2.1	K2.2	K2.3
K3.1	K3.2	K3.3	K4.1	K4.2	K4.3	K4.4	K4.5	K5.1	K5.2	K5.3	N3.1	N3.2	N3.3
S1.1	S1.2	S1.3	S2.1	S2.2	S3.1	S3.2	S4.1	S4.2	H1.1	H2.1	H2.2	H3.1	H3.2
H4.1	H4.2												

DC ≤ 6.00 mm: DCON MS tolérance h6; DC > 6.00 mm: brasé sur queue acier avec DCON MS tolérance h7.

Product	DC (mm)	DCON MS (mm)	LU (mm)	OAL (mm)
P8193.0X3.0	3.00	3.00	1.50	38.0
P8196.0X6.0	6.00	6.00	3.00	50.0
P8199.6X6.0 ¹⁾	9.60	6.00	4.70	53.0
P81912.7X6.0 ¹⁾	12.70	6.00	6.30	55.0
P81916.0X6.0 ¹⁾	16.00	6.00	8.00	57.0

¹⁾ Brazed on steel shank

P821



Fraise lime rotative – Conique à bout rond, forme L, finition brillante

Denture double type DC avec goujures rapprochées. Convient pour agrandir des trous, arrondir des arêtes et finir des surfaces dans des zones difficiles à atteindre. Conception en carbure monobloc pour les Ø de coupe jusqu'à 6 mm et tête en carbure brasée sur une queue en acier trempé et durci au-dessus de Ø6 mm.

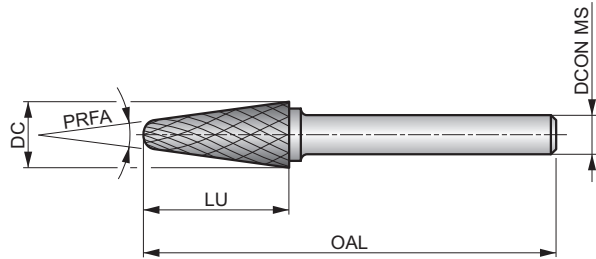

HM		Bright
DC		



Adéquation du groupe de matériaux de la pièce. Vitesse de fonctionnement recommandée (RPM) à la page 277.

P1.1	P1.2	P1.3	P2.1	P2.2	P2.3	P3.1	P3.2	P3.3	P4.1	P4.2	P4.3	M1.1	M1.2
M2.1	M2.2	M2.3	M3.1	M3.2	M3.3	M4.1	M4.2	K1.1	K1.2	K1.3	K2.1	K2.2	K2.3
K3.1	K3.2	K3.3	K4.1	K4.2	K4.3	K4.4	K4.5	K5.1	K5.2	K5.3	N3.1	N3.2	N3.3
S1.1	S1.2	S1.3	S2.1	S2.2	S3.1	S3.2	S4.1	S4.2	H1.1	H2.1	H2.2	H3.1	H3.2
H4.1	H4.2												

DC ≤ 6.00 mm: DCON MS tolérance h6; DC > 6.00 mm: brasé sur queue acier avec DCON MS tolérance h7.
Les produits de cette série sont également disponibles en coffret. Voir P880 ou P890.

Product	DC (mm)	DCON MS (mm)	LU (mm)	OAL (mm)	PRFA (°)
P8213.0X3.0	3.00	3.00	14.00	38.0	8
P8216.0X6.0	6.00	6.00	18.00	50.0	14
P8218.0X6.0 ¹⁾	8.00	6.00	25.40	70.0	14
P8219.6X6.0 ¹⁾	9.60	6.00	30.00	76.0	14
P82112.7X6.0 ¹⁾	12.70	6.00	32.00	77.0	14
P82116.0X6.0 ¹⁾	16.00	6.00	33.00	78.0	14

¹⁾ Brazed on steel shank

P821C



Fraise lime rotative – Conique à bout rond, forme L, revêtement TiAlN

Denture double type DC avec goujures rapprochées. Convient pour agrandir des trous, arrondir des arêtes et finir des surfaces dans des zones difficiles à atteindre. Conception en carbure monobloc pour les Ø de coupe jusqu'à 6 mm et tête en carbure brasée sur une queue en acier trempé et durci au-dessus de Ø6 mm. Revêtement TiAlN pour une durée de vie accrue de l'outil.

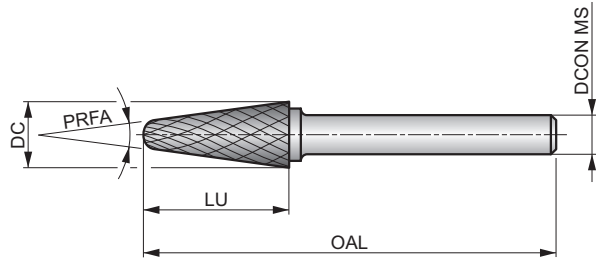

HM		
DC		



Adéquation du groupe de matériaux de la pièce. Vitesse de fonctionnement recommandée (RPM) à la page 277.

P1.1	P1.2	P1.3	P2.1	P2.2	P2.3	P3.1	P3.2	P3.3	P4.1	P4.2	P4.3	M1.1	M1.2
M2.1	M2.2	M2.3	M3.1	M3.2	M3.3	M4.1	M4.2	K1.1	K1.2	K1.3	K2.1	K2.2	K2.3
K3.1	K3.2	K3.3	K4.1	K4.2	K4.3	K4.4	K4.5	K5.1	K5.2	K5.3	N3.1	N3.2	N3.3
S1.1	S1.2	S1.3	S2.1	S2.2	S3.1	S3.2	S4.1	S4.2	H1.1	H2.1	H2.2	H3.1	H3.2
H4.1	H4.2												

DC ≤ 6.00 mm: DCON MS tolérance h6; DC > 6.00 mm: brasé sur queue acier avec DCON MS tolérance h7.

Product	DC (mm)	DCON MS (mm)	LU (mm)	OAL (mm)	PRFA (°)
P821C3.0X3.0	3.00	3.00	14.00	38.0	8
P821C12.7X6.0 ¹⁾	12.70	6.00	32.00	77.0	14

¹⁾ Brazed on steel shank

P823



Fraise lime rotative – Conique à bout pointu, forme M

Denture double type DC avec goujures rapprochées. Convient pour agrandir des trous, la finition de surface et la coupe d'angles étroits dans des zones difficiles à atteindre. Conception en carbure monobloc pour les Ø de coupe jusqu'à 6 mm et tête en carbure brasée sur une queue en acier trempé et durci au-dessus de Ø6 mm.

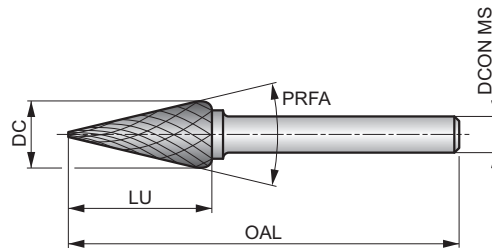

HM		Bright
DC		



Adéquation du groupe de matériaux de la pièce. Vitesse de fonctionnement recommandée (RPM) à la page 277.

P1.1	P1.2	P1.3	P2.1	P2.2	P2.3	P3.1	P3.2	P3.3	P4.1	P4.2	P4.3	M1.1	M1.2
M2.1	M2.2	M2.3	M3.1	M3.2	M3.3	M4.1	M4.2	K1.1	K1.2	K1.3	K2.1	K2.2	K2.3
K3.1	K3.2	K3.3	K4.1	K4.2	K4.3	K4.4	K4.5	K5.1	K5.2	K5.3	N3.1	N3.2	N3.3
S1.1	S1.2	S1.3	S2.1	S2.2	S3.1	S3.2	S4.1	S4.2	H1.1	H2.1	H2.2	H3.1	H3.2
H4.1	H4.2												

DC ≤ 6.00 mm: DCON MS tolérance h6; DC > 6.00 mm: brasé sur queue acier avec DCON MS tolérance h7.
Les produits de cette série sont également disponibles en coffret. Voir P880.

Product	DC (mm)	DCON MS (mm)	LU (mm)	OAL (mm)	PRFA (°)
P8233.0X3.0	3.00	3.00	11.00	38.0	14
P8236.3X3.0 ¹⁾	6.30	3.00	12.70	49.0	22
P8236.0X6.0	6.00	6.00	20.00	50.0	14
P8239.6X6.0 ¹⁾	9.60	6.00	16.00	64.0	28
P82312.7X6.0 ¹⁾	12.70	6.00	22.00	71.0	28
P82316.0X6.0 ¹⁾	16.00	6.00	25.00	71.0	31

¹⁾ Brazed on steel shank

P825



Fraise lime rotative – Conique inversé, forme N

Denture double type DC avec goujures rapprochées. Convient pour réaliser des coupes en V inversé et pour le chanfreinage latéral arrière. Conception en carbure monobloc pour les Ø de coupe jusqu'à 6 mm et tête en carbure brasée sur une queue en acier trempé et durci au-dessus de Ø6 mm.

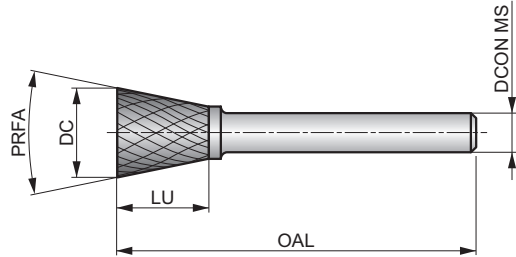

HM		Bright
DC		



Adéquation du groupe de matériaux de la pièce. Vitesse de fonctionnement recommandée (RPM) à la page 277.

P1.1	P1.2	P1.3	P2.1	P2.2	P2.3	P3.1	P3.2	P3.3	P4.1	P4.2	P4.3	M1.1	M1.2
M2.1	M2.2	M2.3	M3.1	M3.2	M3.3	M4.1	M4.2	K1.1	K1.2	K1.3	K2.1	K2.2	K2.3
K3.1	K3.2	K3.3	K4.1	K4.2	K4.3	K4.4	K4.5	K5.1	K5.2	K5.3	N3.1	N3.2	N3.3
S1.1	S1.2	S1.3	S2.1	S2.2	S3.1	S3.2	S4.1	S4.2	H1.1	H2.1	H2.2	H3.1	H3.2
H4.1	H4.2												

DC ≤ 6.00 mm: DCON MS tolérance h6; DC > 6.00 mm: brasé sur queue acier avec DCON MS tolérance h7.

Product	DC (mm)	DCON MS (mm)	LU (mm)	OAL (mm)	PRFA (°)
P8253.0X3.0	3.00	3.00	4.00	38.0	10
P8256.3X3.0 ¹⁾	6.30	3.00	6.00	39.0	12
P8256.0X6.0	6.00	6.00	8.00	50.0	10
P8259.6X6.0 ¹⁾	9.60	6.00	9.50	55.0	16
P82512.7X6.0 ¹⁾	12.70	6.00	12.70	58.0	28
P82516.0X6.0 ¹⁾	16.00	6.00	19.00	64.0	18

¹⁾ Brazed on steel shank

Code de matériau du corps (BMC)

Code du type de fraise lime (BTC)

Forme de fraise lime

Revêtement

Groupe standard de base (BSG)

Géométrie en bout d'une fraise lime

HM	HM	HM	HM	HM	HM	HM	HM	HM						
ST	ST	ST	ST	ST	ST	ST	ST	ST	ST					
A	B	C	D	E	F	G	H	L						
Bright	Bright	Bright	Bright	Bright	Bright	Bright	Bright	Bright	Bright					
DORMER	DORMER	DORMER	DORMER	DORMER	DORMER	DORMER	DORMER	DORMER	DORMER					

Code de famille de produits

Plage de diamètres de coupe PSF

P701	P703	P705	P707	P709	P711	P713	P715	P721						
6.00 – 12.70	6.00 – 12.70	6.00 – 12.70	6.00 – 12.70	12.70	6.00 – 12.70	6.00 – 12.70	8.00 – 12.70	9.60 – 12.70						
204	205	206	207	208	209	210	211	212						

P	P1	■	■	■	■	■	■	■	■					
	P2	■	■	■	■	■	■	■	■					
	P3	■	■	■	■	■	■	■	■					
	P4	■	■	■	■	■	■	■	■					
M	M1													
	M2													
	M3													
	M4													
K	K1													
	K2													
	K3													
	K4													
	K5													
N	N1													
	N2													
	N3													
	N4													
	N5													
S	S1													
	S2													
	S3													
	S4													
H	H1													
	H2													
	H3													
	H4													

P701



Fraise lime rotative – Cylindrique sans coupe en bout, forme A

Denture simple type ST avec brise-copeaux et goujures moyennement espacées. Convient pour tailler et ébavurer des surfaces. Conception en carbure monobloc pour les Ø de coupe jusqu'à 6 mm et tête en carbure brasée sur une queue en acier trempé et durci au-dessus de Ø6 mm. Premier choix pour les aciers.

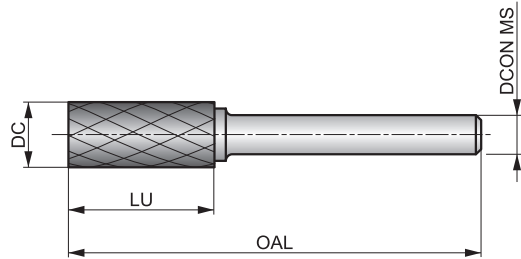

HM	A	Bright
ST	DORMER	

Adéquation du groupe de matériaux de la pièce. Vitesse de fonctionnement recommandée (RPM) à la page 277.

P1.1	P1.2	P1.3	P2.1	P2.2	P2.3	P3.1	P3.2	P3.3	P4.1	P4.2	P4.3
■	■	■	■	■	■	■	■	■	■	■	■

DC=6.00 mm: DCON MS tolérance h6; DC > 6.00 mm: Brasé sur queue acier avec DCON MS tolérance h7.

Product	DC (mm)	DCON MS (mm)	LU (mm)	OAL (mm)
P7016.0X6.0	6.00	6.00	18.00	50.0
P7018.0X6.0 ¹⁾	8.00	6.00	19.00	64.0
P7019.6X6.0 ¹⁾	9.60	6.00	19.00	64.0
P70112.7X6.0 ¹⁾	12.70	6.00	25.00	70.0

¹⁾ Brazed on steel shank

P703



Fraise lime rotative – Cylindrique avec coupe en bout, forme B

Denture simple type ST avec brise-copeaux et goujures moyennement espacées. Convient pour tailler et ébavurer des surfaces et des coins à angle droit. Conception en carbure monobloc pour les Ø de coupe jusqu'à 6 mm et tête en carbure brasée sur une queue en acier trempé et durci au-dessus de Ø6 mm. Premier choix pour les aciers.

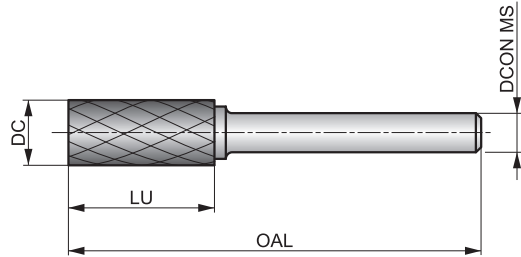

HM	B	
Bright	ST	



Adéquation du groupe de matériaux de la pièce. Vitesse de fonctionnement recommandée (RPM) à la page 277.

- P1.1
- P1.2
- P1.3
- P2.1
- P2.2
- P2.3
- P3.1
- P3.2
- P3.3
- P4.1
- P4.2
- P4.3

DC=6.00 mm: DCON MS tolérance h6; DC > 6.00 mm: Brasé sur queue acier avec DCON MS tolérance h7.
 Les produits de cette série sont également disponibles en coffret. Voir P880.

Product	DC (mm)	DCON MS (mm)	LU (mm)	OAL (mm)
P7036.0X6.0	6.00	6.00	18.00	50.0
P7038.0X6.0 ¹⁾	8.00	6.00	19.00	64.0
P7039.6X6.0 ¹⁾	9.60	6.00	19.00	64.0
P70312.7X6.0 ¹⁾	12.70	6.00	25.00	70.0

¹⁾ Brazed on steel shank

P705



Fraise lime rotative – Cylindrique à bout rond, forme C

Denture simple type ST avec brise-copeaux et goujures moyennement espacées. Convient pour tailler et ébavurer des contours et des arcs de cercle. Conception en carbure monobloc pour les Ø de coupe jusqu'à 6 mm et tête en carbure brasée sur une queue en acier trempé et durci au-dessus de Ø6 mm. Premier choix pour les aciers.

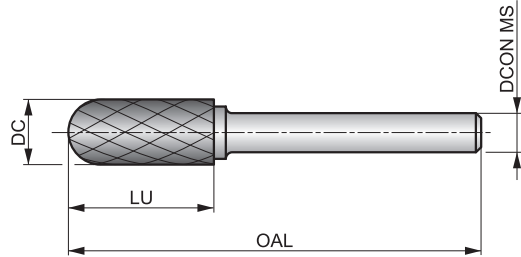

HM		Bright
ST		



Adéquation du groupe de matériaux de la pièce. Vitesse de fonctionnement recommandée (RPM) à la page 277.

P1.1	P1.2	P1.3	P2.1	P2.2	P2.3	P3.1	P3.2	P3.3	P4.1	P4.2	P4.3
■	■	■	■	■	■	■	■	■	■	■	■

DC=6.00 mm: DCON MS tolérance h6; DC > 6.00 mm: Brasé sur queue acier avec DCON MS tolérance h7.
Les produits de cette série sont également disponibles en coffret. Voir P880.

Product	DC (mm)	DCON MS (mm)	LU (mm)	OAL (mm)
P7056.0X6.0	6.00	6.00	18.00	50.0
P7058.0X6.0 ¹⁾	8.00	6.00	19.00	64.0
P7059.6X6.0 ¹⁾	9.60	6.00	19.00	64.0
P70512.7X6.0 ¹⁾	12.70	6.00	25.00	70.0

¹⁾ Brazed on steel shank

P707



Fraise lime rotative – Boule, forme D

Denture simple type ST avec brise-copeaux et goujures moyennement espacées. Convient pour la sculpture de formes complexes, la gravure sur métal et la préparation de soudures. Conception en carbure monobloc pour les Ø de coupe jusqu'à 6 mm et tête en carbure brasée sur une queue en acier trempé et durci au-dessus de Ø6 mm. Premier choix pour les aciers.

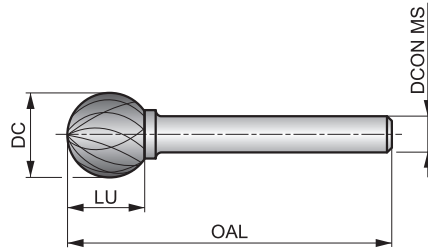

HM	
ST	



Adéquation du groupe de matériaux de la pièce. Vitesse de fonctionnement recommandée (RPM) à la page 277.

P1.1	P1.2	P1.3	P2.1	P2.2	P2.3	P3.1	P3.2	P3.3	P4.1	P4.2	P4.3
■	■	■	■	■	■	■	■	■	■	■	■

DC=6.00 mm: DCON MS tolérance h6; DC > 6.00 mm: Brasé sur queue acier avec DCON MS tolérance h7.
Les produits de cette série sont également disponibles en coffret. Voir P880.

Product	DC (mm)	DCON MS (mm)	LU (mm)	OAL (mm)
P7076.0X6.0	6.00	6.00	4.70	50.0
P7078.0X6.0 ¹⁾	8.00	6.00	6.00	52.0
P7079.6X6.0 ¹⁾	9.60	6.00	8.00	54.0
P70712.7X6.0 ¹⁾	12.70	6.00	11.00	56.0

¹⁾ Brazed on steel shank

P709



Fraise lime rotative – Ovale, forme E

Denture simple type ST avec brise-copeaux et goujures moyennement espacées. Convient pour le contournage des bords ronds. Tête en carbure brasée sur une queue en acier trempé et durci. Premier choix pour les aciers.

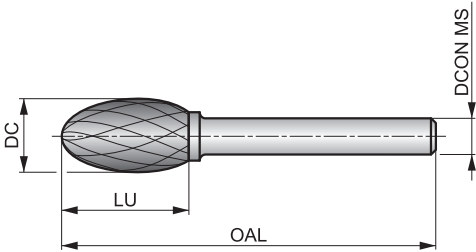

HM	E	Bright
ST		



Adéquation du groupe de matériaux de la pièce. Vitesse de fonctionnement recommandée (RPM) à la page 277.

P1.1	P1.2	P1.3	P2.1	P2.2	P2.3	P3.1	P3.2	P3.3	P4.1	P4.2	P4.3
■	■	■	■	■	■	■	■	■	■	■	■

Brasé sur queue acier avec DCON MS tolérance h7.

Product	DC (mm)	DCON MS (mm)	LU (mm)	OAL (mm)
P70912.7X6.0 ¹⁾	12.70	6.00	22.00	67.0

¹⁾ Brasé on steel shank

P711



Fraise lime rotative – Ogive à bout rond, forme F

Denture simple type ST avec brise-copeaux et goujures moyennement espacées. Convient pour le contournage multi angle, arrondir des arêtes et pour la coupe dans les zones difficiles à atteindre. Conception en carbure monobloc pour les Ø de coupe jusqu'à 6 mm et tête en carbure brasée sur une queue en acier trempé et durci au-dessus de Ø6 mm. Premier choix pour les aciers.

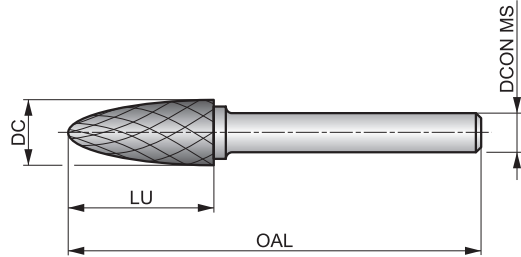

HM	F	Bright
ST		



Adéquation du groupe de matériaux de la pièce. Vitesse de fonctionnement recommandée (RPM) à la page 277.

P1.1	P1.2	P1.3	P2.1	P2.2	P2.3	P3.1	P3.2	P3.3	P4.1	P4.2	P4.3
■	■	■	■	■	■	■	■	■	■	■	■

DC=6.00 mm: DCON MS tolérance h6; DC > 6.00 mm: Brasé sur queue acier avec DCON MS tolérance h7.
Les produits de cette série sont également disponibles en coffret. Voir P880.

Product	DC (mm)	DCON MS (mm)	LU (mm)	OAL (mm)
P7116.0X6.0	6.00	6.00	18.00	50.0
P7118.0X6.0 ¹⁾	8.00	6.00	20.00	65.0
P7119.6X6.0 ¹⁾	9.60	6.00	19.00	64.0
P71112.7X6.0 ¹⁾	12.70	6.00	25.00	70.0

¹⁾ Brazed on steel shank

P713



Fraise lime rotative – Ogive à bout pointu, forme G

Denture simple type ST avec brise-copeaux et goujures moyennement espacées. Convient pour le contournage multi angle, arrondir des arêtes et pour la coupe dans les zones difficiles à atteindre. Conception en carbure monobloc pour les Ø de coupe jusqu'à 6 mm et tête en carbure brasée sur une queue en acier trempé et durci au-dessus de Ø6 mm. Premier choix pour les aciers.

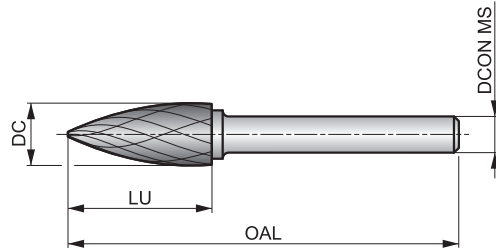

HM		Bright
ST		



Adéquation du groupe de matériaux de la pièce. Vitesse de fonctionnement recommandée (RPM) à la page 277.

P1.1	P1.2	P1.3	P2.1	P2.2	P2.3	P3.1	P3.2	P3.3	P4.1	P4.2	P4.3
■	■	■	■	■	■	■	■	■	■	■	■

DC=6.00 mm: DCON MS tolérance h6; DC > 6.00 mm: Brasé sur queue acier avec DCON MS tolérance h7.

Product	DC (mm)	DCON MS (mm)	LU (mm)	OAL (mm)
P7136.0X6.0	6.00	6.00	18.00	50.0
P7138.0X6.0 ¹⁾	8.00	6.00	19.00	64.0
P7139.6X6.0 ¹⁾	9.60	6.00	19.00	64.0
P71312.7X6.0 ¹⁾	12.70	6.00	25.00	70.0

¹⁾ Brazed on steel shank

P715



Fraise lime rotative – Flamme, forme H

Denture simple type ST avec brise-copeaux et goujures moyennement espacées. Convient pour le contournage des bords ronds et la préparation de soudures. Tête en carbure brasée sur une queue en acier trempé et durci. Premier choix pour les aciers.

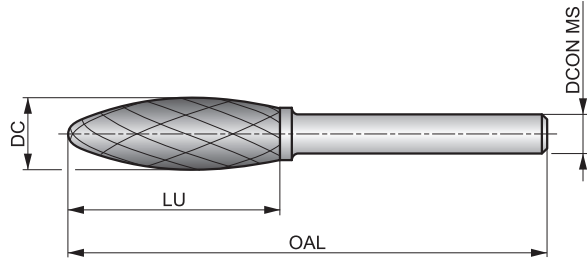

HM	H	Bright
ST	DORMER	



Adéquation du groupe de matériaux de la pièce. Vitesse de fonctionnement recommandée (RPM) à la page 277.

P1.1	P1.2	P1.3	P2.1	P2.2	P2.3	P3.1	P3.2	P3.3	P4.1	P4.2	P4.3
■	■	■	■	■	■	■	■	■	■	■	■

Brasé sur queue acier avec DCON MS tolérance h7.

Product	DC (mm)	DCON MS (mm)	LU (mm)	OAL (mm)
P7158.0X6.0 ¹⁾	8.00	6.00	19.00	64.0
P71512.7X6.0 ¹⁾	12.70	6.00	32.00	77.0

¹⁾ Brasé on steel shank

P721



Fraise lime rotative – Conique à bout rond, forme L

Denture simple type ST avec brise-copeaux et goujures moyennement espacées. Convient pour agrandir des trous, arrondir des arêtes et finir des surfaces dans des zones difficiles à atteindre. Tête en carbure brasée sur une queue en acier trempé et durci. Premier choix pour les aciers.

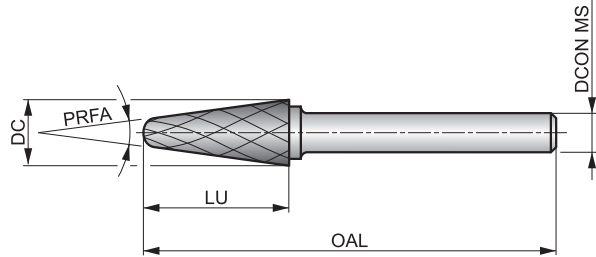

HM		Bright
ST		



Adéquation du groupe de matériaux de la pièce. Vitesse de fonctionnement recommandée (RPM) à la page 277.

P1.1	P1.2	P1.3	P2.1	P2.2	P2.3	P3.1	P3.2	P3.3	P4.1	P4.2	P4.3
■	■	■	■	■	■	■	■	■	■	■	■

Brasé sur queue acier avec DCON MS tolérance h7.
Les produits de cette série sont également disponibles en coffret. Voir P880.

Product	DC (mm)	DCON MS (mm)	LU (mm)	OAL (mm)	PRFA (°)
P72110.0X6.0 ¹⁾	10.00	6.00	20.00	65.0	14
P7219.6X6.0 ¹⁾	9.60	6.00	30.00	76.0	14
P72112.7X6.0 ¹⁾	12.70	6.00	32.00	77.0	14

¹⁾ Brazed on steel shank

ISO
13399PMK
NSH

Code de matériau du corps
(BMC)

Code du type de fraise lime
(BTC)

Forme de fraise lime

Revêtement

Groupe standard de base
(BSG)

HM

HM

HM

HM

HM

HM

HM

HM

VA

VA

VA

VA

VA

VA

VA

VA



Code de famille de produits

Plage de diamètres de coupe
PSF

P601

P605

P607

P609

P611

P613

P615

P621

3.00 – 12.70

3.00 – 12.70

3.00 – 12.70

8.00 – 12.70

3.00 – 12.70

6.00 – 12.70

8.00 – 12.70

8.00 – 12.70



214



215



216



217



218



219



220



221

P

P1

P2

P3

P4

M

M1

M2

M3

M4

K

K1

K2

K3

K4

K5

N

N1

N2

N3

N4

N5

S

S1

S2

S3

S4

H

H1

H2

H3

H4



■ Utilisation principale

▣ Utilisation possible

P601



Fraise lime rotative – Cylindrique sans coupe en bout, forme A

Denture simple type VA avec goujures moyennement espacées. Convient pour tailler et ébavurer des surfaces. Conception en carbure monobloc pour les Ø de coupe jusqu'à 6 mm et tête en carbure brasée sur une queue en acier trempé et durci au-dessus de Ø6 mm. Premier choix pour les aciers inoxydables.

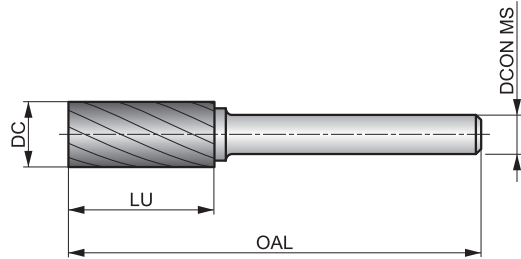

HM	A	Bright
VA		



Adéquation du groupe de matériaux de la pièce. Vitesse de fonctionnement recommandée (RPM) à la page 277.

M1.1	M1.2	M2.1	M2.2	M2.3	M3.1	M3.2	M3.3	M4.1	M4.2	K4.1	K4.2
■	■	■	■	■	■	■	■	■	■	▣	▣

DC ≤ 6.00 mm: DCON MS tolérance h6; DC > 6.00 mm: brasé sur queue acier avec DCON MS tolérance h7.
Les produits de cette série sont également disponibles en coffret. Voir P880.

Product	DC (mm)	DCON MS (mm)	LU (mm)	OAL (mm)
P6013.0X3.0	3.00	3.00	14.00	38.0
P6016.3X3.0 ¹⁾	6.30	3.00	12.70	45.0
P6016.0X6.0	6.00	6.00	18.00	50.0
P6018.0X6.0 ¹⁾	8.00	6.00	19.00	64.0
P6019.6X6.0 ¹⁾	9.60	6.00	19.00	64.0
P60112.7X6.0 ¹⁾	12.70	6.00	25.00	70.0

¹⁾ Brazed on steel shank

P605



Fraise lime rotative – Cylindrique à bout rond, forme C

Denture simple type VA avec goujures moyennement espacées. Convient pour tailler et ébavurer des contours et des arcs circulaires. Conception en carbure monobloc pour les Ø de coupe jusqu'à 6 mm et tête en carbure brasée sur une queue en acier trempé et durci au-dessus de Ø6 mm. Premier choix pour les aciers inoxydables.

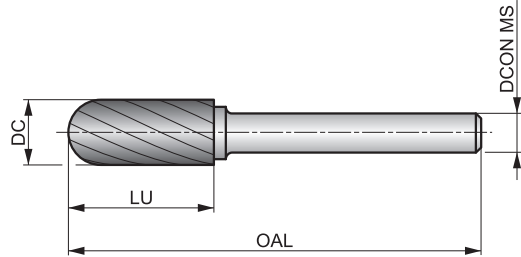

HM		Bright
VA		



Adéquation du groupe de matériaux de la pièce. Vitesse de fonctionnement recommandée (RPM) à la page 277.

M1.1	M1.2	M2.1	M2.2	M2.3	M3.1	M3.2	M3.3	M4.1	M4.2	K4.1	K4.2
■	■	■	■	■	■	■	■	■	■	▣	▣

DC ≤ 6.00 mm: DCON MS tolérance h6; DC > 6.00 mm: brasé sur queue acier avec DCON MS tolérance h7.
Les produits de cette série sont également disponibles en coffret. Voir P880.

Product	DC (mm)	DCON MS (mm)	LU (mm)	OAL (mm)
P6053.0X3.0	3.00	3.00	14.00	38.0
P6056.3X3.0 ¹⁾	6.30	3.00	12.70	45.0
P6056.0X6.0	6.00	6.00	18.00	50.0
P6058.0X6.0 ¹⁾	8.00	6.00	19.00	64.0
P6059.6X6.0 ¹⁾	9.60	6.00	19.00	64.0
P60512.7X6.0 ¹⁾	12.70	6.00	25.00	70.0

¹⁾ Brazed on steel shank

P607



Fraise lime rotative – Boule, forme D

Denture simple type VA avec goujures moyennement espacées. Convient pour la sculpture de formes complexes, la gravure sur métal et la préparation de soudures. Conception en carbure monobloc pour les Ø de coupe jusqu'à 6 mm et tête en carbure brasée sur une queue en acier trempé et durci au-dessus de Ø6 mm. Premier choix pour les aciers inoxydables.

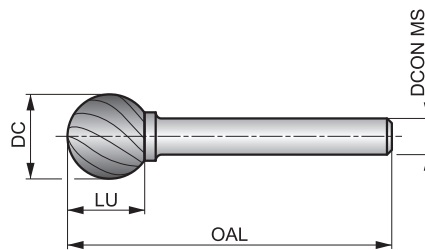

HM		Bright
VA		



Adéquation du groupe de matériaux de la pièce. Vitesse de fonctionnement recommandée (RPM) à la page 277.

M1.1	M1.2	M2.1	M2.2	M2.3	M3.1	M3.2	M3.3	M4.1	M4.2	K4.1	K4.2
■	■	■	■	■	■	■	■	■	■	▣	▣

DC ≤ 6.00 mm: DCON MS tolérance h6; DC > 6.00 mm: brasé sur queue acier avec DCON MS tolérance h7.
Les produits de cette série sont également disponibles en coffret. Voir P880.

Product	DC (mm)	DCON MS (mm)	LU (mm)	OAL (mm)
P6073.0X3.0	3.00	3.00	2.50	38.0
P6076.3X3.0 ¹⁾	6.30	3.00	5.00	38.0
P6076.0X6.0	6.00	6.00	4.70	50.0
P6078.0X6.0 ¹⁾	8.00	6.00	6.00	52.0
P6079.6X6.0 ¹⁾	9.60	6.00	8.00	54.0
P60712.7X6.0 ¹⁾	12.70	6.00	11.00	56.0

¹⁾ Brazed on steel shank

P609



Fraise lime rotative – Ovale, forme E

Denture simple type VA avec goujures moyennement espacées. Convient pour le contournage des bords ronds. Tête en carbure brasée sur une queue en acier trempé et durci. Premier choix pour les aciers inoxydables.

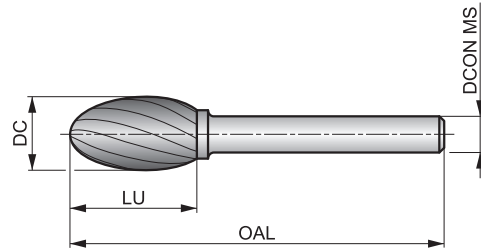

HM	E	Bright
VA		



Adéquation du groupe de matériaux de la pièce. Vitesse de fonctionnement recommandée (RPM) à la page 277.

M1.1	M1.2	M2.1	M2.2	M2.3	M3.1	M3.2	M3.3	M4.1	M4.2	K4.1	K4.2
■	■	■	■	■	■	■	■	■	■	▣	▣

Brasé sur queue acier avec DCON MS tolérance h7.

Product	DC (mm)	DCON MS (mm)	LU (mm)	OAL (mm)
P6098.0X6.0 ¹⁾	8.00	6.00	15.00	60.0
P6099.6X6.0 ¹⁾	9.60	6.00	16.00	60.0
P60912.7X6.0 ¹⁾	12.70	6.00	22.00	67.0

¹⁾ Brazed on steel shank

P611

DORMER



Fraise lime rotative – Ogive à bout rond, forme F

Denture simple type VA avec goujures moyennement espacées. Convient pour le contourage multi angle, arrondir des arêtes et pour la coupe dans les zones difficiles à atteindre. Conception en carbure monobloc pour les Ø de coupe jusqu'à 6 mm et tête en carbure brasée sur une queue en acier trempé et durci au-dessus de Ø6 mm. Premier choix pour les aciers inoxydables.

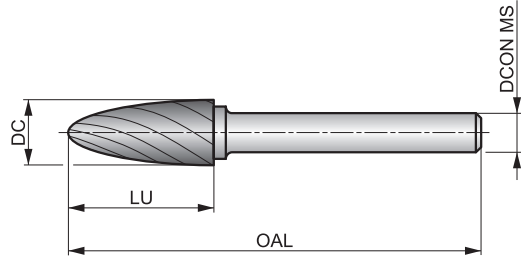

HM	F	Bright
VA		



Adéquation du groupe de matériaux de la pièce. Vitesse de fonctionnement recommandée (RPM) à la page 277.

M1.1	M1.2	M2.1	M2.2	M2.3	M3.1	M3.2	M3.3	M4.1	M4.2	K4.1	K4.2
■	■	■	■	■	■	■	■	■	■	▣	▣

DC ≤ 6.00 mm: DCON MS tolérance h6; DC > 6.00 mm: brasé sur queue acier avec DCON MS tolérance h7.
Les produits de cette série sont également disponibles en coffret. Voir P880.

Product	DC (mm)	DCON MS (mm)	LU (mm)	OAL (mm)
P6113.0X3.0	3.00	3.00	14.00	38.0
P6116.3X3.0 ¹⁾	6.30	3.00	12.70	45.0
P6116.0X6.0	6.00	6.00	18.00	50.0
P6118.0X6.0 ¹⁾	8.00	6.00	20.00	65.0
P6119.6X6.0 ¹⁾	9.60	6.00	19.00	64.0
P61112.7X6.0 ¹⁾	12.70	6.00	25.00	70.0

¹⁾ Brazed on steel shank

P613



Fraise lime rotative – Ogive à bout pointu, forme G

Denture simple type VA avec goujures moyennement espacées. Convient pour le contournage multi angle et la coupe d'angles étroits dans des zones difficiles à atteindre. Conception en carbure monobloc pour les Ø de coupe jusqu'à 6 mm et tête en carbure brasée sur une queue en acier trempé et durci au-dessus de Ø6 mm. Premier choix pour les aciers inoxydables.

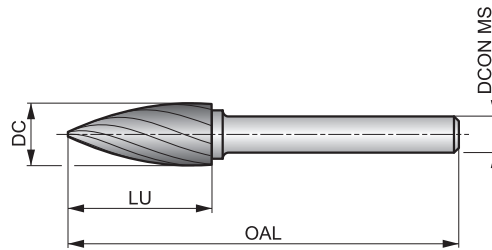

HM	G	Bright
VA		



Adéquation du groupe de matériaux de la pièce. Vitesse de fonctionnement recommandée (RPM) à la page 277.

M1.1	M1.2	M2.1	M2.2	M2.3	M3.1	M3.2	M3.3	M4.1	M4.2	K4.1	K4.2
■	■	■	■	■	■	■	■	■	■	▣	▣

DC=6.00 mm: DCON MS tolérance h6; DC > 6.00 mm: Brasé sur queue acier avec DCON MS tolérance h7.

Product	DC (mm)	DCON MS (mm)	LU (mm)	OAL (mm)
P6136.0X6.0	6.00	6.00	18.00	50.0
P6138.0X6.0 ¹⁾	8.00	6.00	19.00	64.0
P6139.6X6.0 ¹⁾	9.60	6.00	19.00	64.0
P61312.7X6.0 ¹⁾	12.70	6.00	25.00	70.0

¹⁾ Brazed on steel shank

P615



Fraise lime rotative – Flamme, forme H

Denture simple type VA avec goujures moyennement espacées. Convient pour le contournage des bords ronds et la préparation de soudures. Tête en carbure brasée sur une queue en acier trempé et durci. Premier choix pour les aciers inoxydables.

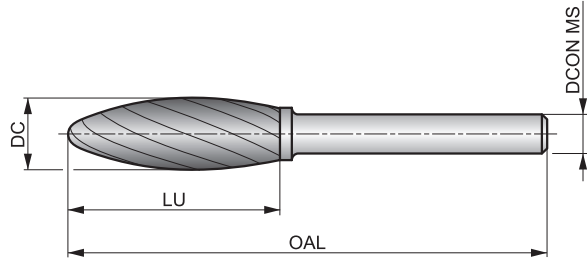

HM		Bright
VA		



Adéquation du groupe de matériaux de la pièce. Vitesse de fonctionnement recommandée (RPM) à la page 277.

M1.1	M1.2	M2.1	M2.2	M2.3	M3.1	M3.2	M3.3	M4.1	M4.2	K4.1	K4.2
■	■	■	■	■	■	■	■	■	■	▣	▣

Brasé sur queue acier avec DCON MS tolérance h7.

Product	DC (mm)	DCON MS (mm)	LU (mm)	OAL (mm)
P6158.0X6.0 ¹⁾	8.00	6.00	19.00	64.0
P6159.6X6.0 ¹⁾	9.60	6.00	19.00	65.0
P61512.7X6.0 ¹⁾	12.70	6.00	32.00	77.0

¹⁾ Brazed on steel shank

P621



Fraise lime rotative – Conique à bout rond, forme L

Denture simple type VA avec goujures moyennement espacées. Convient pour agrandir des trous, arrondir des arêtes et finir des surfaces dans des zones difficiles à atteindre. Tête en carbure brasée sur une queue en acier trempé et durci. Premier choix pour les aciers inoxydables.

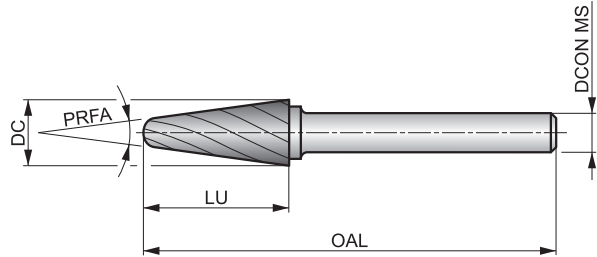

HM		Bright
VA		



Adéquation du groupe de matériaux de la pièce. Vitesse de fonctionnement recommandée (RPM) à la page 277.

M1.1	M1.2	M2.1	M2.2	M2.3	M3.1	M3.2	M3.3	M4.1	M4.2	K4.1	K4.2
■	■	■	■	■	■	■	■	■	■	▣	▣

Brasé sur queue acier avec DCON MS tolérance h7.
Les produits de cette série sont également disponibles en coffret. Voir P880.

Product	DC (mm)	DCON MS (mm)	LU (mm)	OAL (mm)	PRFA (°)
P6218.0X6.0 ¹⁾	8.00	6.00	25.40	70.0	14
P62110.0X6.0 ¹⁾	10.00	6.00	20.00	65.0	14
P62112.7X6.0 ¹⁾	12.70	6.00	32.00	77.0	14

¹⁾ Brazed on steel shank

Code de matériau du corps (BMC)	HM	HM	HM	HM	HM	HM	HM	HM										
Code du type de fraise lime (BTC)	AL	AL	AL	AL	AL	AL	GRP	GRP										
Forme de fraise lime																		
Revêtement	Bright	Bright	Bright	Bright	Bright	Bright	Bright	Bright										
Groupe standard de base (BSG)																		
Angle d'application																		
Géométrie en bout d'une fraise lime																		



Code de famille de produits	P831	P833	P835	P837	P841	P842	P843	P844										
Plage de diamètres de coupe PSF	6.00 – 12.70	6.00 – 12.70	6.00 – 12.70	6.00 – 12.70	6.00 – 12.70	6.00 – 12.70	3.00 – 8.00	3.00 – 8.00										
	224	225	226	227	228	229	230	231										

P	P1																	
	P2																	
	P3																	
	P4																	
M	M1																	
	M2																	
	M3																	
	M4																	
K	K1																	
	K2																	
	K3																	
	K4																	
	K5																	
N	N1	■	■	■	■	■	■											
	N2	■	■	■	■	■	■											
	N3	▣	▣	▣	▣	▣	▣											
	N4	■	■	■	■	■	■	■	■									
	N5																	
S	S1	▣	▣	▣	▣	▣	▣											
	S2																	
	S3																	
	S4																	
H	H1																	
	H2																	
	H3																	
	H4																	

P831



Fraise lime rotative – Cylindrique sans coupe en bout, forme A

Denture simple type AL avec un grand volume de goujure. Convient pour le taillage et l'ébarbage de surfaces. Conception en carbure monobloc pour les Ø de coupe jusqu'à 6 mm et tête en carbure brasée sur une queue en acier trempé et durci au-dessus de Ø6 mm. Premier choix pour les matériaux non-ferreux et les plastiques.

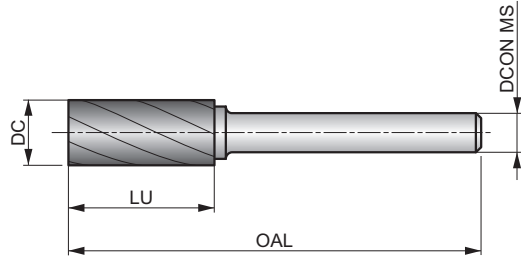

HM	A	Bright
AL		

Adéquation du groupe de matériaux de la pièce. Vitesse de fonctionnement recommandée (RPM) à la page 277.

N1.1	N1.2	N1.3	N2.1	N2.2	N2.3	N3.1	N3.2	N4.1	N4.2	N4.3	S1.1
■	■	■	■	■	■	▣	▣	■	■	▣	▣

DC = 6.00 mm: DCON MS tolérance h6; DC > 6.00 mm: Brasé sur queue acier avec DCON MS tolérance h7.

Product	DC (mm)	DCON MS (mm)	LU (mm)	OAL (mm)
P8316.0X6.0	6.00	6.00	18.00	50.0
P8319.6X6.0 ¹⁾	9.60	6.00	19.00	64.0
P83112.7X6.0 ¹⁾	12.70	6.00	25.00	70.0

¹⁾ Brazed on steel shank

P833



Fraise lime rotative – Cylindrique avec coupe en bout, forme B

Denture simple type AL avec un grand volume de goujure. Convient pour tailler et ébavurer des surfaces et des coins à angle droit. Conception en carbure monobloc pour les Ø de coupe jusqu'à 6 mm et tête en carbure brasée sur une queue en acier trempé et durci au-dessus de Ø6 mm. Premier choix pour les matériaux non-ferreux et les plastiques.

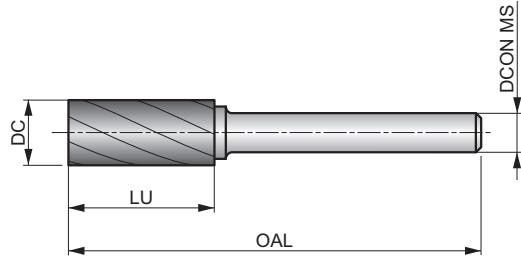

HM	B	
Bright	AL	DORMER



Adéquation du groupe de matériaux de la pièce. Vitesse de fonctionnement recommandée (RPM) à la page 277.

N1.1	N1.2	N1.3	N2.1	N2.2	N2.3	N3.1	N3.2	N4.1	N4.2	N4.3	S1.1
■	■	■	■	■	■	▣	▣	■	■	▣	▣

DC = 6.00 mm: DCON MS tolérance h6; DC > 6.00 mm: Brasé sur queue acier avec DCON MS tolérance h7.

Product	DC (mm)	DCON MS (mm)	LU (mm)	OAL (mm)
P8336.0X6.0	6.00	6.00	18.00	50.0
P8339.6X6.0 ¹⁾	9.60	6.00	19.00	64.0
P83312.7X6.0 ¹⁾	12.70	6.00	25.00	70.0

¹⁾ Brazed on steel shank

P835



Fraise lime rotative – Cylindrique à bout rond, forme C

Denture simple type AL avec un grand volume de goujure. Convient pour le taillage et l'ébarbage de contours et d'arcs circulaires. Conception en carbure monobloc pour les Ø de coupe jusqu'à 6 mm et tête en carbure brasée sur une queue en acier trempé et durci au-dessus de Ø6 mm. Premier choix pour les matériaux non-ferreux et les plastiques.

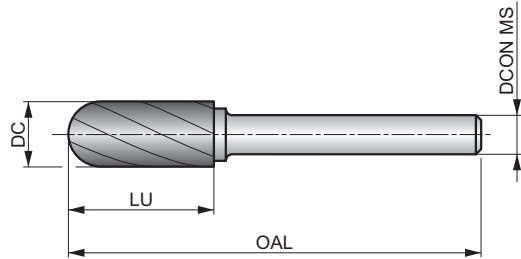

HM	
AL	



Adéquation du groupe de matériaux de la pièce. Vitesse de fonctionnement recommandée (RPM) à la page 277.

N1.1	N1.2	N1.3	N2.1	N2.2	N2.3	N3.1	N3.2	N4.1	N4.2	N4.3	S1.1
■	■	■	■	■	■	▣	▣	■	■	▣	▣

DC = 6.00 mm: DCON MS tolérance h6; DC > 6.00 mm: Brasé sur queue acier avec DCON MS tolérance h7.

Product	DC (mm)	DCON MS (mm)	LU (mm)	OAL (mm)
P8356.0X6.0	6.00	6.00	18.00	50.0
P8359.6X6.0 ¹⁾	9.60	6.00	19.00	64.0
P83512.7X6.0 ¹⁾	12.70	6.00	25.00	70.0

¹⁾ Brazed on steel shank

P837



Fraise lime rotative – Boule, forme D

Denture simple type AL avec grand volume de goujure. Convient pour la sculpture de formes complexes, la gravure sur métal et la préparation de soudures. Conception en carbure monobloc pour les Ø de coupe jusqu'à 6 mm et tête en carbure brasée sur une queue en acier trempé et durci au-dessus de Ø6 mm. Premier choix pour les matériaux non-ferreux et les plastiques.

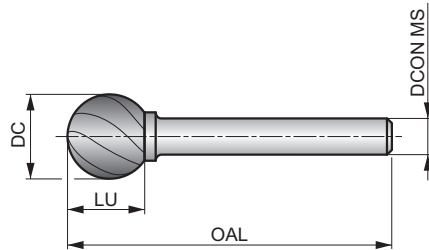

HM		Bright
AL		



Adéquation du groupe de matériaux de la pièce. Vitesse de fonctionnement recommandée (RPM) à la page 277.

N1.1	N1.2	N1.3	N2.1	N2.2	N2.3	N3.1	N3.2	N4.1	N4.2	N4.3	S1.1
■	■	■	■	■	■	▣	▣	■	■	▣	▣

DC = 6.00 mm: DCON MS tolérance h6; DC > 6.00 mm: Brasé sur queue acier avec DCON MS tolérance h7.

Product	DC (mm)	DCON MS (mm)	LU (mm)	OAL (mm)
P8376.0X6.0	6.00	6.00	4.70	50.0
P8379.6X6.0 ¹⁾	9.60	6.00	8.00	54.0
P83712.7X6.0 ¹⁾	12.70	6.00	11.00	56.0

¹⁾ Brazed on steel shank

P841



Fraise lime rotative – Ogive à bout rond, forme F

Denture simple type AL avec un grand volume de goujure. Convient pour le contournage multi angle, arrondir des arêtes et pour couper dans des zones difficiles à atteindre. Conception en carbure monobloc pour les Ø de coupe jusqu'à 6 mm et tête en carbure brasée sur une queue en acier trempé et durci au-dessus de Ø6 mm. Premier choix pour les matériaux non-ferreux et les plastiques.

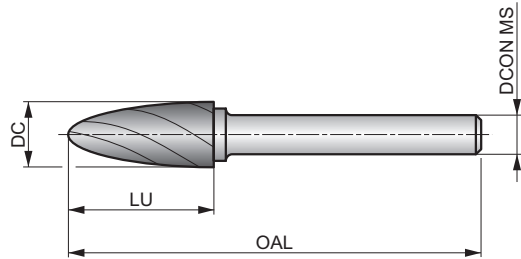

HM	F	Bright
AL		



Adéquation du groupe de matériaux de la pièce. Vitesse de fonctionnement recommandée (RPM) à la page 277.

N1.1	N1.2	N1.3	N2.1	N2.2	N2.3	N3.1	N3.2	N4.1	N4.2	N4.3	S1.1
■	■	■	■	■	■	▣	▣	■	■	▣	▣

DC = 6.00 mm: DCON MS tolérance h6; DC > 6.00 mm: Brasé sur queue acier avec DCON MS tolérance h7.

Product	DC (mm)	DCON MS (mm)	LU (mm)	OAL (mm)
P8416.0X6.0	6.00	6.00	18.00	50.0
P8419.6X6.0 ¹⁾	9.60	6.00	19.00	64.0
P84112.7X6.0 ¹⁾	12.70	6.00	25.00	70.0

¹⁾ Brazed on steel shank

P842



Fraise lime rotative – Conique à bout rond, forme L

Denture simple type AL avec un grand volume de goujure. Convient pour agrandir des trous, arrondir des arêtes et finir des surfaces dans des zones difficiles à atteindre. Conception en carbure monobloc pour les Ø de coupe jusqu'à 6 mm et tête en carbure brasée sur une queue en acier trempé et durci au-dessus de Ø6 mm. Premier choix pour les matériaux non-ferreux et les plastiques.

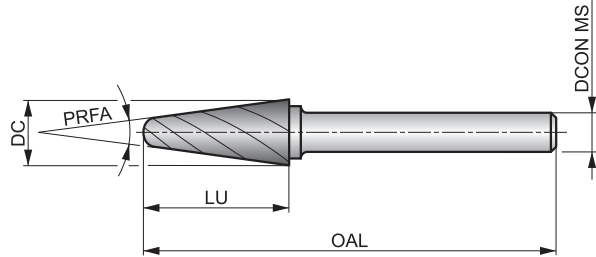

HM		Bright
AL		



Adéquation du groupe de matériaux de la pièce. Vitesse de fonctionnement recommandée (RPM) à la page 277.

N1.1	N1.2	N1.3	N2.1	N2.2	N2.3	N3.1	N3.2	N4.1	N4.2	N4.3	S1.1
■	■	■	■	■	■	▣	▣	■	■	▣	▣

DC = 6.00 mm: DCON MS tolérance h6; DC > 6.00 mm: Brasé sur queue acier avec DCON MS tolérance h7.

Product	DC (mm)	DCON MS (mm)	LU (mm)	OAL (mm)	PRFA (°)
P8426.0X6.0	6.00	6.00	18.00	50.0	14
P8429.6X6.0 ¹⁾	9.60	6.00	30.00	76.0	14
P84212.7X6.0 ¹⁾	12.70	6.00	32.00	77.0	14

¹⁾ Brazed on steel shank

P843



Fraise lime rotative – Cylindrique avec pointe à 135 degrés, denture croisée type diamant

Denture diamant type GRP avec goujures moyennement rapprochées. Convient pour le contournage, la découpe de forme et le perçage. Queue en carbure pour plus de rigidité. Premier choix pour la fibre de verre et les matériaux composites.

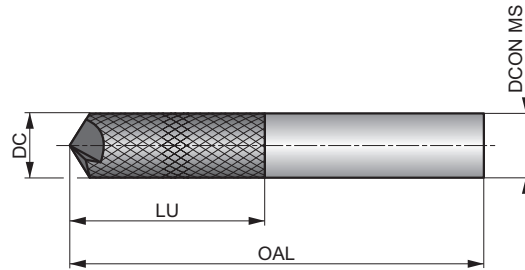

HM	Bright
135°	GRP

Adéquation du groupe de matériaux de la pièce. Vitesse de fonctionnement recommandée (RPM) à la page 277.

N4.3

DCON MS tolérance h6.

Product	DC (mm)	DCON MS (mm)	LU (mm)	OAL (mm)
P8433.0X3.0	3.00	3.00	13.00	45.0
P8436.0X6.0	6.00	6.00	19.00	63.0
P8438.0X8.0	8.00	8.00	25.00	63.0



P844



Fraise lime rotative – Cylindrique avec coupe en bout, denture croisée type diamant

Denture diamant type GRP avec goujures moyennement rapprochées. Convient pour le contourage, le fraisage de rainures ou de poches et la réalisation de découpes. Queue en carbure pour plus de rigidité. Premier choix pour la fibre de verre et les matériaux composites.

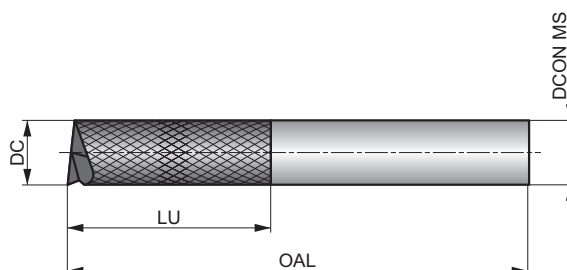

HM



GRP



Adéquation du groupe de matériaux de la pièce. Vitesse de fonctionnement recommandée (RPM) à la page 277.

N4.3

DCON MS tolérance h6.

Product	DC (mm)	DCON MS (mm)	LU (mm)	OAL (mm)
P8443.0X3.0	3.00	3.00	13.00	45.0
P8446.0X6.0	6.00	6.00	19.00	63.0
P8448.0X8.0	8.00	8.00	25.00	63.0

ISO
13399PMK
NSHCode de matériau du corps
(BMC)Code du type de fraise lime
(BTC)

Forme de fraise lime

Revêtement

Groupe standard de base
(BSG)

HM	HM	HM	HM	HM	HM	HM	HM	HM										
AS	AS	AS	AS	AS	AS	AS	AS	AS	AS									
A	C	D	E	F	G	H	L	M										
Bright	Bright	Bright	Bright	Bright	Bright	Bright	Bright	Bright	Bright									
DORMER	DORMER	DORMER	DORMER	DORMER	DORMER	DORMER	DORMER	DORMER	DORMER									



Code de famille de produits

Plage de diamètres de coupe
PSF

P501	P505	P507	P509	P511	P513	P515	P521	P523										
3.00	3.00	3.00	3.00	3.00	3.00	3.00	3.00	3.00										
234	235	236	237	238	239	240	241	242										

P	P1																	
	P2																	
	P3																	
	P4																	
M	M1																	
	M2																	
	M3	■	■	■	■	■	■	■	■	■								
	M4	■	■	■	■	■	■	■	■	■								
K	K1																	
	K2																	
	K3																	
	K4																	
	K5																	
N	N1																	
	N2																	
	N3																	
	N4																	
	N5																	
S	S1	■	■	■	■	■	■	■	■	■								
	S2	■	■	■	■	■	■	■	■	■								
	S3	■	■	■	■	■	■	■	■	■								
	S4	■	■	■	■	■	■	■	■	■								
H	H1																	
	H2																	
	H3																	
	H4																	

■ Utilisation principale

■ Utilisation possible

P501



Fraise lime rotative – Cylindrique sans coupe en bout, forme A

Denture simple type AS avec une légère coupe transversale à gauche. Convient pour tailler et ébavurer des surfaces. Queue en carbure pour plus de rigidité. Premier choix pour les superalliages.

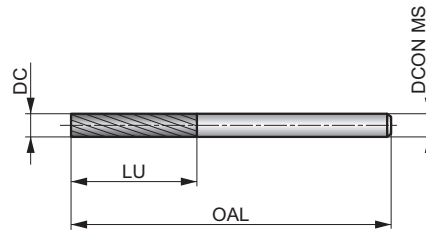

HM	A	Bright
AS		



Adéquation du groupe de matériaux de la pièce. Vitesse de fonctionnement recommandée (RPM) à la page 277.

M3.1	M3.2	M3.3	M4.1	M4.2	S1.1	S1.2	S1.3	S2.1	S2.2	S3.1	S3.2	S4.1	S4.2
<input checked="" type="checkbox"/>	<input checked="" type="checkbox"/>	<input checked="" type="checkbox"/>	<input checked="" type="checkbox"/>	<input checked="" type="checkbox"/>	<input type="checkbox"/>	<input type="checkbox"/>	<input type="checkbox"/>	<input type="checkbox"/>	<input type="checkbox"/>	<input type="checkbox"/>	<input type="checkbox"/>	<input type="checkbox"/>	<input type="checkbox"/>

DCON MS tolérance h6.

Les produits de cette série sont également disponibles en coffret. Voir P880.

Product	DC (mm)	DCON MS (mm)	LU (mm)	OAL (mm)
P5013.0X3.0	3.00	3.00	12.00	38.0

P505



Fraise lime rotative – Cylindrique à bout rond, forme C

Denture simple type AS avec une légère coupe transversale à gauche. Convient pour tailler et ébavurer des contours et des arcs circulaires. Queue en carbure pour plus de rigidité. Premier choix pour les superalliages.

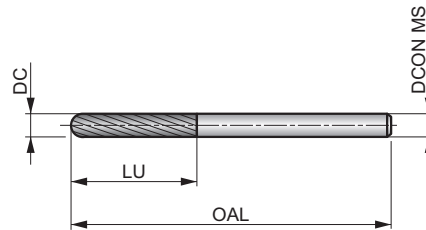

HM	C	Bright
AS		



Adéquation du groupe de matériaux de la pièce. Vitesse de fonctionnement recommandée (RPM) à la page 277.

M3.1	M3.2	M3.3	M4.1	M4.2	S1.1	S1.2	S1.3	S2.1	S2.2	S3.1	S3.2	S4.1	S4.2
<input checked="" type="checkbox"/>	<input checked="" type="checkbox"/>	<input checked="" type="checkbox"/>	<input checked="" type="checkbox"/>	<input checked="" type="checkbox"/>	<input type="checkbox"/>	<input type="checkbox"/>	<input type="checkbox"/>	<input type="checkbox"/>	<input type="checkbox"/>	<input type="checkbox"/>	<input type="checkbox"/>	<input type="checkbox"/>	<input type="checkbox"/>

DCON MS tolérance h6.
Les produits de cette série sont également disponibles en coffret. Voir P880.

Product	DC (mm)	DCON MS (mm)	LU (mm)	OAL (mm)
P5053.0X3.0	3.00	3.00	14.00	38.0

P507



Fraise lime rotative – Boule, forme D

Denture simple type AS avec une légère coupe transversale à gauche. Convient pour la sculpture de formes complexes, la gravure sur métal et la préparation de soudure. Queue en carbure pour plus de rigidité. Premier choix pour les superalliages.

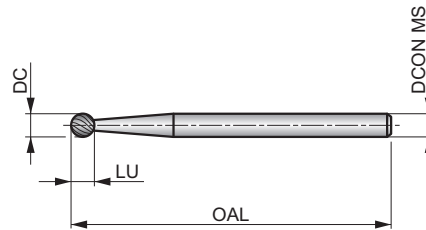

HM		Bright
AS		



Adéquation du groupe de matériaux de la pièce. Vitesse de fonctionnement recommandée (RPM) à la page 277.

M3.1	M3.2	M3.3	M4.1	M4.2	S1.1	S1.2	S1.3	S2.1	S2.2	S3.1	S3.2	S4.1	S4.2
<input checked="" type="checkbox"/>	<input checked="" type="checkbox"/>	<input checked="" type="checkbox"/>	<input checked="" type="checkbox"/>	<input checked="" type="checkbox"/>	<input type="checkbox"/>	<input type="checkbox"/>	<input type="checkbox"/>	<input type="checkbox"/>	<input type="checkbox"/>	<input type="checkbox"/>	<input type="checkbox"/>	<input type="checkbox"/>	<input type="checkbox"/>

DCON MS tolérance h6.

Les produits de cette série sont également disponibles en coffret. Voir P880.

Product	DC (mm)	DCON MS (mm)	LU (mm)	OAL (mm)
P5073.0X3.0	3.00	3.00	2.50	38.0

P509



Fraise lime rotative – Ovale, forme E

Denture simple type AS avec une légère coupe transversale à gauche. Convient pour le contournage des bords arrondis. Queue en carbure pour plus de rigidité. Premier choix pour les superalliages.

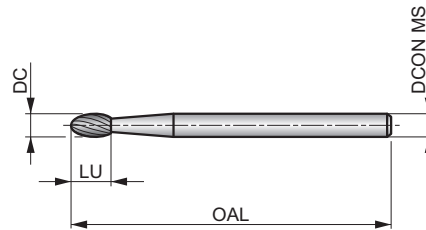

HM	E	Bright
AS		



Adéquation du groupe de matériaux de la pièce. Vitesse de fonctionnement recommandée (RPM) à la page 277.

M3.1	M3.2	M3.3	M4.1	M4.2	S1.1	S1.2	S1.3	S2.1	S2.2	S3.1	S3.2	S4.1	S4.2
<input checked="" type="checkbox"/>	<input checked="" type="checkbox"/>	<input checked="" type="checkbox"/>	<input checked="" type="checkbox"/>	<input checked="" type="checkbox"/>	<input type="checkbox"/>	<input type="checkbox"/>	<input type="checkbox"/>	<input type="checkbox"/>	<input type="checkbox"/>	<input type="checkbox"/>	<input type="checkbox"/>	<input type="checkbox"/>	<input type="checkbox"/>

DCON MS tolérance h6.

Les produits de cette série sont également disponibles en coffret. Voir P880.

Product	DC (mm)	DCON MS (mm)	LU (mm)	OAL (mm)
P5093.0X3.0	3.00	3.00	6.00	38.0

P511



Fraise lime rotative – Ogive à bout rond, forme F

Denture simple type AS avec une légère coupe transversale à gauche. Convient pour le contournage multi angle, arrondir des arêtes et pour la coupe dans les zones difficiles à atteindre. Queue en carbure pour plus de rigidité. Premier choix pour les superalliages.

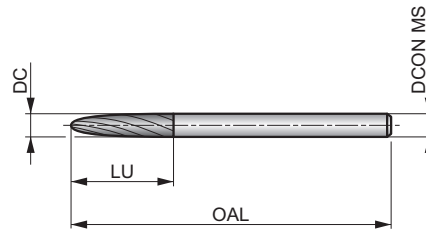

HM	F	Bright
AS		



Adéquation du groupe de matériaux de la pièce. Vitesse de fonctionnement recommandée (RPM) à la page 277.

M3.1	M3.2	M3.3	M4.1	M4.2	S1.1	S1.2	S1.3	S2.1	S2.2	S3.1	S3.2	S4.1	S4.2
☑	☑	☑	☑	☑	☐	☐	☐	☐	☐	☐	☐	☐	☐

DCON MS tolérance h6.

Les produits de cette série sont également disponibles en coffret. Voir P880.

Product	DC (mm)	DCON MS (mm)	LU (mm)	OAL (mm)
P5113.0X3.0	3.00	3.00	14.00	38.0

P513



Fraise lime rotative – Ogive à bout pointu, forme G

Denture simple type AS avec une légère coupe transversale à gauche. Convient pour le contourage multi angle et la coupe d'angles étroits dans les zones difficiles à atteindre. Queue en carbure pour plus de rigidité. Premier choix pour les superalliages.

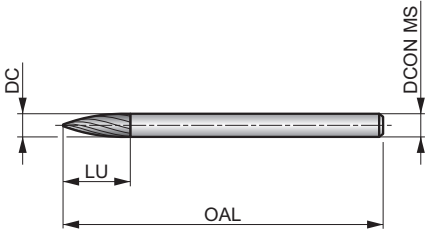

HM	G	Bright			
AS	DORMER				

Adéquation du groupe de matériaux de la pièce. Vitesse de fonctionnement recommandée (RPM) à la page 277.

M3.1	M3.2	M3.3	M4.1	M4.2	S1.1	S1.2	S1.3	S2.1	S2.2	S3.1	S3.2	S4.1	S4.2
☑	☑	☑	☑	☑	☐	☐	☐	☐	☐	☐	☐	☐	☐

DCON MS tolérance h6.
Les produits de cette série sont également disponibles en coffret. Voir P880.

Product	DC (mm)	DCON MS (mm)	LU (mm)	OAL (mm)
P5133.0X3.0X8.0	3.00	3.00	8.00	38.0
P5133.0X3.0X14.0	3.00	3.00	14.00	38.0

P515



Fraise lime rotative – Flamme, forme H

Denture simple type AS avec une légère coupe transversale à gauche. Convient pour le contourage des bords arrondis et la préparation de soudures. Queue en carbure pour plus de rigidité. Premier choix pour les superalliages.

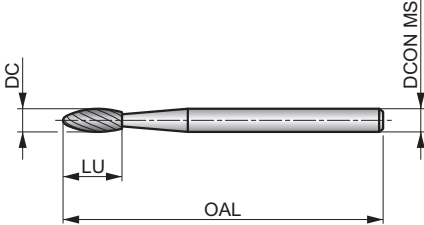

HM	H	Bright		
AS	DORMER			

Adéquation du groupe de matériaux de la pièce. Vitesse de fonctionnement recommandée (RPM) à la page 277.

M3.1	M3.2	M3.3	M4.1	M4.2	S1.1	S1.2	S1.3	S2.1	S2.2	S3.1	S3.2	S4.1	S4.2
☑	☑	☑	☑	☑	☐	☐	☐	☐	☐	☐	☐	☐	☐

DCON MS tolérance h6.
Les produits de cette série sont également disponibles en coffret. Voir P880.

Product	DC (mm)	DCON MS (mm)	LU (mm)	OAL (mm)
P5153.0X3.0	3.00	3.00	6.00	38.0



P521



Fraise lime rotative – Conique à bout rond, forme L

Denture simple type AS avec une légère coupe transversale à gauche. Convient pour agrandir des trous, arrondir des arêtes et finir des surfaces dans des angles étroits ou d'autres zones difficiles à atteindre. Queue en carbure pour plus de rigidité. Premier choix pour les superalliages.

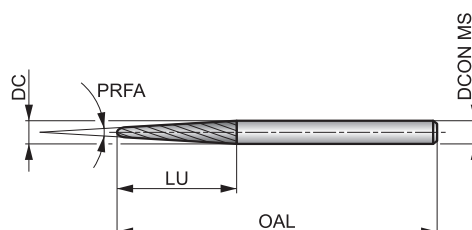

HM		Bright
AS		



Adéquation du groupe de matériaux de la pièce. Vitesse de fonctionnement recommandée (RPM) à la page 277.

M3.1	M3.2	M3.3	M4.1	M4.2	S1.1	S1.2	S1.3	S2.1	S2.2	S3.1	S3.2	S4.1	S4.2
<input checked="" type="checkbox"/>	<input checked="" type="checkbox"/>	<input checked="" type="checkbox"/>	<input checked="" type="checkbox"/>	<input checked="" type="checkbox"/>	<input type="checkbox"/>	<input type="checkbox"/>	<input type="checkbox"/>	<input type="checkbox"/>	<input type="checkbox"/>	<input type="checkbox"/>	<input type="checkbox"/>	<input type="checkbox"/>	<input type="checkbox"/>

DCON MS tolérance h6.

Les produits de cette série sont également disponibles en coffret. Voir P880.

Product	DC (mm)	DCON MS (mm)	LU (mm)	OAL (mm)	PRFA (°)
P5213.0X3.0	3.00	3.00	14.00	38.0	8

P523



Fraise lime rotative – Conique à bout pointu, forme M

Denture simple type AS avec une légère coupe transversale à gauche. Convient pour agrandir des trous, la finition de surface et pour la coupe d'angles étroits dans des zones difficiles à atteindre. Queue en carbure pour plus de rigidité. Premier choix pour les superalliages.

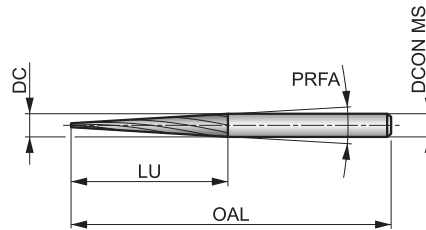

HM	M	Bright
AS		

Adéquation du groupe de matériaux de la pièce. Vitesse de fonctionnement recommandée (RPM) à la page 277.

M3.1	M3.2	M3.3	M4.1	M4.2	S1.1	S1.2	S1.3	S2.1	S2.2	S3.1	S3.2	S4.1	S4.2
<input checked="" type="checkbox"/>	<input checked="" type="checkbox"/>	<input checked="" type="checkbox"/>	<input checked="" type="checkbox"/>	<input checked="" type="checkbox"/>	<input type="checkbox"/>	<input type="checkbox"/>	<input type="checkbox"/>	<input type="checkbox"/>	<input type="checkbox"/>	<input type="checkbox"/>	<input type="checkbox"/>	<input type="checkbox"/>	<input type="checkbox"/>

DCON MS tolérance h6.
Les produits de cette série sont également disponibles en coffret. Voir P880.

Product	DC (mm)	DCON MS (mm)	LU (mm)	OAL (mm)	PRFA (°)
P5233.0X3.0	3.00	3.00	15.00	38.0	7

Code de matériau du corps (BMC)
 Code du type de fraise lime (BTC)
 Revêtement
 Groupe standard de base (BSG)
 Angle d'application
 Géométrie en bout d'une fraise lime

HM

HM

HM

HM

BR

BR

Bright

Bright

DORMER

DORMER

150°



Code de famille de produits
 Plage de diamètres de coupe PSF

P880

P890

P100

P101

M902

Set

Set

4.90 – 10.70

4.90 – 10.70

Set

244

245

246

247

248

P	P1			■	■								
	P2			■	■								
	P3			■	■								
	P4			■	■								
M	M1			■	■								
	M2			■	■								
	M3			■	■								
	M4												
K	K1												
	K2												
	K3												
	K4												
	K5												
N	N1												
	N2												
	N3												
	N4												
	N5												
S	S1												
	S2												
	S3												
	S4												
H	H1												
	H2												
	H3												
	H4												



P880

DORMER



Coffret de fraises limes rotatives

Coffret de différentes fraises limes rotatives dans une variété de formes et de tailles.

A = Types dans le coffret, B = Quantité dans le coffret, C = Fraises limes dans le coffret.

Product	Nr.	A	B	C
P88001	Nr01	P803 + P805 + P807 + P809 + P813	5	P8039.6X6.0; P8059.6X6.0; P8079.6X6.0; P8099.6X6.0; P8139.6X6.0
P88002	Nr02	P803C + P805C + P807C + P811C + P813C	5	P803C9.6X6.0; P805C9.6X6.0; P807C9.6X6.0; P811C9.6X6.0; P813C9.6X6.0
P88003	Nr03	P601 + P605 + P607 + P611 + P621	5	P6019.6X6.0; P6059.6X6.0; P6079.6X6.0; P6119.6X6.0; P62110.0X6.0
P88004	Nr04	P703 + P705 + P707 + P711 + P721	5	P7039.6X6.0; P7059.6X6.0; P7079.6X6.0; P7119.6X6.0; P72110.0X6.0
P88006	Nr06	P501 + P505 + P507 + P509 + P511 + P513 + P515 + P521 + P523	10	P5013.0x3.0; P5053.0x3.0; P5073.0x3.0; P5093.0x3.0; P5113.0x3.0; P5133.0x3.0x8.0; P5133.0x3.0x14.0; P5153.0x3.0; P5213.0x3.0; P5233.0x3.0

P890



Présentoir de fraises limes rotatives

Présentoir contenant 40 fraises limes rotatives de la série P8xx. Fraises à denture double type DC avec goujures rapprochées. Finition brillante.

A = Types dans le coffret, B = Quantité dans le coffret, C = Fraises limes dans le coffret.

Product	Nr.	A	B	C
P89001EMPTY	-	-	-	-
P89001	Nr01	P803 + P805 + P811 + P813 + P821	40	P803(6.0X6.0; 8.0X6.0; 9.6X6.0; 12.7X6.0) X 2; P805(6.0X6.0; 8.0X6.0; 9.6X6.0; 12.7X6.0) X 2; P811(6.0X6.0; 8.0X6.0; 9.6X6.0; 12.7X6.0) X 2; P813(6.0X6.0; 8.0X6.0; 9.6X6.0; 12.7X6.0) X 2; P821(6.0X6.0; 8.0X6.0; 9.6X6.0; 12.7X6.0) X 2

P100



Fraise lime rotative pour la 1ère étape de retrait de boulons cassés, cylindrique avec coupe en bout

Fraise en carbure à utiliser en première étape lors du retrait d'un boulon cassé. Lorsqu'un boulon cassé doit être extrait, utilisez d'abord la fraise P100 pour aplanir la surface du boulon cassé. Ensuite, utilisez la fraise P101. Cette série de fraises permet de s'assurer que le trou taraudé ne sera pas endommagé lors du retrait de la partie cassée.

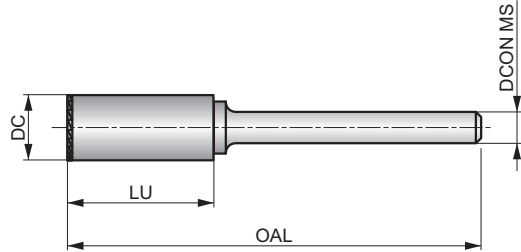

HM		Bright
BR		

Adéquation du groupe de matériaux de la pièce. Vitesse de fonctionnement recommandée (RPM) à la page 277.

P1.1	P1.2	P1.3	P2.1	P2.2	P2.3	P3.1	P3.2	P3.3	P4.1	P4.2	M1.1	M1.2	M2.1
■	■	■	■	■	■	■	■	■	■	■	■	■	■
M2.2	M2.3	M3.1	M3.2	M3.3									
■	■	■	■	■									

Product	DC (mm)	DCON MS (mm)	LU (mm)	OAL (mm)	
P1004.9	4.90	6.00	20.00	50.0	1/4-20; 24; 28; M6
P1006.4	6.40	6.00	5.00	50.0	5/16-18; 24; 32; M8
P1007.8	7.80	6.00	19.00	65.0	3/8-16; 24; M10
P1009.3	9.30	6.00	19.00	65.0	7/16-14; 20; M12
P10010.7	10.70	6.00	25.00	70.0	1/2-13; 20; M14

P101



Fraise lime rotative pour la deuxième étape de retrait de boulons cassés, fraise à 150°

Fraise en carbure à utiliser en deuxième étape du retrait d'un boulon cassé. Lorsqu'un boulon cassé doit être extrait, la fraise P101 crée un point de centre dans le boulon cassé aplani. Préparez-le ainsi avant d'effectuer la 3ème étape, le perçage du boulon avec une perceuse.

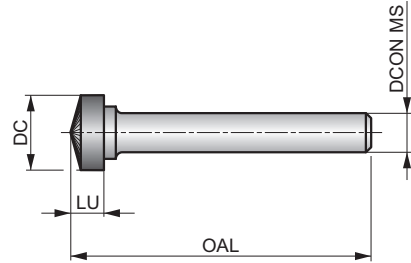

HM	Bright	150°
BR	DORMER	



Adéquation du groupe de matériaux de la pièce. Vitesse de fonctionnement recommandée (RPM) à la page 277.

P1.1	P1.2	P1.3	P2.1	P2.2	P2.3	P3.1	P3.2	P3.3	P4.1	P4.2	M1.1	M1.2	M2.1
■	■	■	■	■	■	■	■	■	■	■	■	■	■
M2.2	M2.3	M3.1	M3.2	M3.3									
■	■	■	■	■									

Product	DC (mm)	DCON MS (mm)	LU (mm)	OAL (mm)	
P1014.9	4.90	6.00	20.00	50.0	1/4-20; 24; 28; M6
P1016.4	6.40	6.00	5.00	50.0	5/16-18; 24; 32; M8
P1017.8	7.80	6.00	5.00	50.0	3/8-16; 24; M10
P1019.3	9.30	6.00	5.00	50.0	7/16-14; 20; M12
P10110.7	10.70	6.00	5.00	50.0	1/2-13; 20; M14



M902

DORMER



Kit extracteur de vis

Les outils pour retirer les boulons cassés (avec filets à droite) sont livrés par kit de quatre. Dans un premier temps, utilisez la fraise à font plat P100 pour aplatir le boulon. Dans un deuxième temps, utilisez la fraise conique P101 pour créer un centre de départ. Dans un troisième temps, utilisez le foret court HSS-E A117 pour percer un trou pour l'extracteur. Enfin, utilisez l'extracteur de vis dans le sens anti-horaire pour retirer le boulon

A = Types dans le coffret, B = Quantité dans le coffret, C = Diamètres dans le coffret.

Product	Nr.	A	B	C
M902M6-M8	M6 – M8	M900, P100, P101, A117	4	P1004.9, P1014.9, A1173.0, M9002
M902M8-M10	M8 – M10	M900, P100, P101, A117	4	P1006.4, P1016.4, A1174.0, M9003
M902M10-M12	M10 – M12	M900, P100, P101, A117	4	P1007.8, P1017.8, A1174.2, M9003
M902M12-M14	M12 – M14	M900, P100, P101, A117	4	P1009.3, P1019.3, A1176.0, M9004
M902M14-M16	M14 – M16	M900, P100, P101, A117	4	P10010.7, P10110.7, A1178.0, M9005



PMK
NSH



INSTRUCTIONS

FRAISES MONOBLOCS – PAGE DE PRÉSENTATION

1 S771HB

DORMER



2 Fraise trochoïdale en carbure monobloc à 5 dents avec brise-copeaux, arrosage centralisé

Fraise à 5 dents avec hélice variable, une longueur de coupe courte et un détalonnage permettant de réduire les vibrations, en particulier lors de l'utilisation avec des stratégies de fraisage dynamique. Le revêtement AlCrN améliore les performances et prolonge la durée de vie de l'outil. Le brise-copeaux et l'arrosage centralisé améliorent l'évacuation des copeaux dans les opérations de poche.

HM	FS	NOF 5
	$\lambda \neq$	$\gamma 10^\circ$
DIN 6535HB	AlCrN	DC h9

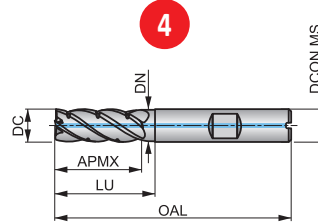

Adéquation du groupe de matériaux de la pièce, valeurs de départ pour la vitesse de coupe (m/min) et code alpha. Tableaux d'avances par dent et facteurs de correction à partir de la page 266.

P1.1 ■ 222 J	P1.2 ■ 248 J	P1.3 ■ 255 J	P2.1 ■ 189 J	P2.2 ■ 166 J	P2.3 ■ 147 J	P3.1 ■ 153 J	P3.2 ■ 123 J	P3.3 ■ 104 J	P4.1 ■ 90 J	P4.2 ■ 78 J	M1.1 ■ 128 J	M1.2 ■ 108 J	M2.1 ■ 113 J
M2.2 ■ 93 J	M3.1 ■ 105 J	M3.2 ■ 90 J	K1.1 ■ 218 J	K1.2 ■ 162 J	K1.3 ■ 122 J	K2.1 ■ 225 J	K2.2 ■ 183 J	K2.3 ■ 146 J	K3.1 ■ 198 J	K3.2 ■ 152 J	K3.3 ■ 123 J	K4.1 ■ 185 J	K4.2 ■ 139 J
K4.3 ■ 102 J	K4.4 ■ 87 J	K4.5 ■ 72 J	K5.1 ■ 209 J	K5.2 ■ 156 J	K5.3 ■ 122 J	S1.2 ■ 76 J	S2.1 ■ 59 J	S3.1 ■ 44 G	S4.1 ■ 35 G				

DCON MS tolérance h6; RE ±0.01 mm.

Product	DC (mm)	RE (mm)	DCON MS (mm)	APMX (mm)	OAL (mm)	NOF	LU (mm)	DN (mm)
S771HB10.0	10.00	0.20	10.00	25.00	72.0	5	30.00	9.70
S771HB12.0	12.00	0.20	12.00	30.00	83.0	5	38.00	11.70
S771HB16.0	16.00	0.30	16.00	39.00	92.0	5	44.00	15.70
S771HB20.0	20.00	0.30	20.00	48.00	104.0	5	54.00	19.70

Élém.	Description
1	Désignation de la fraise monobloc
2	Descriptif du produit
3	Illustration
4	Schéma de l'outil
5	Caractéristiques du produit











Élém.	Description
6	Type de fraisage
7	Recommandations en fonction du groupe de matériaux, notamment indication de la vitesse et de l'avance
8	Code produit
9	Dimensions du produit

PRÉSENTATION DES ICÔNES

Îcônes générales

<input type="checkbox"/>	Utilisation principale	<input checked="" type="checkbox"/>	Utilisation possible
--------------------------	------------------------	-------------------------------------	----------------------





Profil de fraise

N 	Profil pour usage général dans les matériaux de faible à haute résistance	NRA 	Brise-copeaux grand pas rond asymétrique		Pas fin
FS 	Brise-copeaux semi-finition	NR 	Brise-copeaux grand pas rond		Grand pas
HRA 	Brise-copeaux pas fin rond asymétrique	W 	Profil adapté aux non-ferreux et aux matériaux malléables tendres		
NF 	Brise-copeaux grand pas plat	W NRA 	Profil type non-ferreux avec brise-copeaux grand pas rond asymétrique		

Nombre de goujures (NOF)

	Nombre de goujures = 1 (une dent)		Nombre de goujures = 3 – 6 (dents)		Nombre de goujures = 6 – 12 (dents)
	Nombre de goujures = 2 (dents)		Nombre de goujures = 4 (dents)		Nombre de goujures = 6 – 8 (dents)
	Nombre de goujures = 3 (dents)		Nombre de goujures = 4 (pas différentiel)		Nombre de goujures = 8 (dents)
	Nombre de goujures = 3 (pas différentiel)		Nombre de goujures = 4 – 5 (dents)		Nombre de goujures = 10 – 12 (dents)
	Nombre de goujures = 3 – 4 (dents)		Nombre de goujures = 4 – 6 (dents)		
	Nombre de goujures = 3 – 5 (dents)		Nombre de goujures = 5 (dents)		

Longueur de coupe

	Longueur de coupe courte		Longueur de coupe longue		Longueur de coupe extra-longue
	Longueur de coupe moyenne		Longueur de coupe extra-courte		

Angle d'hélice de goujure (FHA)

	Angle d'hélice 0° (goujure droite)		Angle d'hélice 28° (goujure)		Angle d'hélice 40° (goujure)
	Angle d'hélice 10° (goujure)		Angle d'hélice 30° (goujure)		Angle d'hélice 45° (goujure)
	Angle d'hélice 15° (goujure)		Angle d'hélice 34° (goujure)		Angle d'hélice 50° (goujure)
	Angle d'hélice 25° (goujure)		Angle d'hélice 35° (goujure)		Hélice variable (inégle)

PRÉSENTATION DES ICÔNES











Angle de coupe radial (GAMF)

 -26°	Angle de coupe radial -26° (coupe)	 5°	Angle de coupe radial 5° (coupe)	 13°	Angle de coupe radial 13° (coupe)
 -10°	Angle de coupe radial -10° (coupe)	 7°	Angle de coupe radial 7° (coupe)	 20°	Angle de coupe radial 20° (coupe)
 -6°	Angle de coupe radial -6° (coupe)	 8°	Angle de coupe radial 8° (coupe)	 15°	Angle de coupe radial 15° (coupe)
 0°	Angle de coupe radial 0° (coupe)	 9°	Angle de coupe radial 9° (coupe)	 18°	Angle de coupe radial 18° (coupe)
 3°	Angle de coupe radial 3° (coupe)	 10°	Angle de coupe radial 10° (coupe)		
 4°	Angle de coupe radial 4° (coupe)	 12°	Angle de coupe radial 12° (coupe)		



Queue

 DIN 1835B	Queue Weldon DIN 1835 B	 DIN 6535HA	Queue cylindrique DIN 6535 HA	 DIN 1835A	Queue cylindrique DIN 1835 A
 DIN 6535HB	Queue Weldon DIN 6535 HB	 DIN 1835	Queue DIN 1835 B (Weldon) ou D (filetée)		

Classe de tolérance du diamètre de coupe (TCDC)

 d11	d11 – Tolérance de perçage norme usine (selon diamètre)	 h11	h11 – Tolérance de perçage norme usine (selon diamètre)	 k10	k10 – Tolérance de perçage norme usine (selon diamètre)
 e8	e8 – Tolérance de perçage norme usine (selon diamètre)	 h12	h12 – Tolérance de perçage norme usine (selon diamètre)	 k12	k12 – Tolérance de perçage norme usine (selon diamètre)
 h9	h9 – Tolérance de perçage norme usine (selon diamètre)	 js14	js14 – Tolérance de perçage norme usine (selon diamètre)		
 h10	h10 – Tolérance de perçage norme usine (selon diamètre)	 js16	js16 – Tolérance de perçage norme usine (selon diamètre)		

Direction de coupe













 Radiale, oblique, axiale	 Radiale
 Radiale, oblique	 Radiale

Arrosage (CSP)





 Arrosage centralisé

PRÉSENTATION DES ICÔNES

Groupe standard de base (BSG)

 Normes Dormer	 DIN 6527 K – Spécifications fraises carbure	 DIN 851 – Spécifications fraises pour rainures en T
 DIN 327 D – Spécifications fraises à rainurer	 DIN 1880 – Spécifications fraises 2 tailles	 DIN 885 A – Spécifications fraises 3 tailles
 DIN 844 L – Spécifications fraises en bout HSS	 DIN 1837 – Spécifications fraises-scies à denture fine	 DIN 1833 C – Spécifications fraises coniques
 DIN 844 K – Spécifications fraises en bout	 DIN 1838 – Spécifications fraises-scies à denture grossière	
 DIN 6527 L – Spécifications fraises carbure	 DIN 850 – Spécifications fraises à logement clavette	









Angle d'application

 Cône 60°	 Pointe à 135°	 Foret à pointer 150°
 Cône 90°	 Pointe à 180°	







Géométrie en bout d'une fraise lime

 Coupe en bout spéciale	 Coupe en bout standard	 A pointe perçante
---	--	---

Forme de fraise lime

 A Cylindrique sans coupe en bout	 F Ogive à bout rond	 L Conique à bout rond
 B Cylindrique avec coupe en bout	 G Ogive à bout pointu	 M Conique
 C Cylindrique à bout rond	 H Flamme	 N Cône inversé
 D Sphérique	 J Cône 60°	
 E Ovoïde	 K Cône 90°	

Code du type de fraise lime (BTC)











 ST Géométrie de coupe pour l'acier	 AL Géométrie de coupe pour l'aluminium	 BR Géométrie pour l'extraction de boulons
 VA Géométrie de coupe pour l'acier inoxydable	 GRP Géométrie de coupe pour la fibre de verre et les matériaux composites	
 DC Géométrie à denture croisée	 AS Géométrie de coupe pour les superalliages	

PRÉSENTATION DES ICÔNES













Code de matériau du corps (BMC)

HSS	Substrat acier rapide	HSS-E PM	Substrat acier rapide fritté à teneur en cobalt
HSS-E	Substrat acier rapide à teneur en cobalt	HM	Substrat dur (carbure monobloc)

Revêtement

 Bright	Brillant (non revêtu)	 TiSiN	Revêtement nitrure de silicium titane	 AlTiN	Revêtement aluminium nitrure de titane
 Hi	Finition de surface brillante polie	 TiCN	Revêtement carbonitrure de titane	 Alcrona	Revêtement nitrure de chrome aluminium
 ST	Traitement vapeur (oxyde)	 TiAlN	Nitrure de titane aluminium	 AlCrN	Revêtement nitrure de chrome aluminium
 X-CEED	Revêtement spécial AlTiN (haute résistance à l'oxydation)	 Diamond	Revêtement type diamant		

Opérations d'ébavurage

 Ébavurage – Retrait de boulon, opération 1	 Ébavurage et sculpture de surfaces incurvées	 Ébavurage inversé
 Ébavurage – Retrait de boulon, opération 2	 Ébavurage de rayons de filets	 Ébavurage en pleine matière
 Ébavurage et sculpture de rainures fermées	 Ébavurage et sculpture libres	 Ébavurage d'épaulements
 Usinage de fibres composites	 Ébavurage de chanfreins	 Ébavurage de rainures en V

Autres icônes

	Dimension du boulon
--	---------------------

PARAMÈTRES DES OUTILS DE COUPE SELON LA NORME ISO 13399

Tous les outils de coupe se définissent selon un certain nombre de paramètres arrêtés par la norme ISO 13399. La liste qui suit reprend tous les paramètres mentionnés dans le présent catalogue, accompagnés de leur définition.

La norme ISO 13399 est une norme internationale de représentation des données relatives aux outils de coupe. Il réunit des dimensions et des paramètres dans un format neutre, indépendant de tout système particulier ou de toute nomenclature d'entreprise. Lorsqu'un outil de coupe est clairement défini selon une norme internationale, tous les types de logiciels peuvent traiter les données électroniques plus rapidement, ce qui améliore la qualité des communications et contribue à la fluidité des échanges d'informations. L'emploi d'un langage commun pour décrire nos outils de coupe facilite la communication entre les systèmes. La collecte de données de qualité concernant nos 40 000 outils et plaquettes indexables vous permettra de gagner un temps considérable. En adoptant un système conforme à la norme ISO 13399, il ne sera pas nécessaire d'interpréter les données ni de les saisir manuellement dans votre système.

QUE DES EXEMPLES!

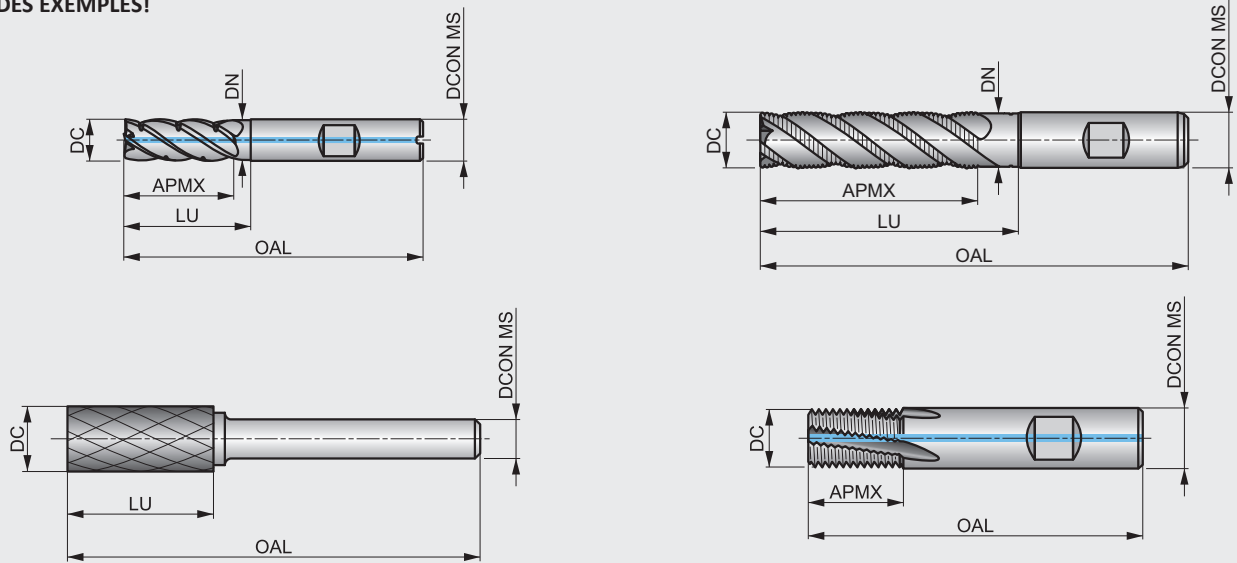

Code ISO 13399	Description
APMX	Profondeur de coupe maximum
BD	Diamètre du corps
BDX	Diamètre du corps maximum
BCH	Longueur du chanfrein d'angle
BS	Longueur d'arête wiper
CBDP	Profondeur d'alésage du raccord
CDI	Diamètre de coupe de la plaquette
CDX	Profondeur de coupe maximum
CW	Largeur de coupe
CZC MS	Code de taille de raccord côté machine
D1	Diamètre du trou de fixation
DAH4	Diamètre de trou d'accès
DAH5	Diamètre de trou d'accès
DAH6	Diamètre de trou d'accès
DBC1	Diamètre du cercle de boulon 1
DBC2	Diamètre du cercle de boulon 2
DBC4	Diamètre du cercle de boulon
DBC5	Diamètre du cercle de boulon
DBC6	Diamètre du cercle de boulon
DC	Diamètre de coupe
DCB	Diamètre d'alésage du raccord
DCCB	Diamètre d'alésage du raccord alésé

Code ISO 13399	Description
DCN	Diamètre de coupe minimum
DCON MS	Diamètre de raccordement côté machine
DCX	Diamètre de coupe maximum
DHUB	Diamètre de moyeu
DN	Diamètre de collet
GAMF	Angle de coupe radial
GAMP	Angle de coupe axial
CHW	Largeur du chanfrein de la pointe
IC	Diamètre du cercle inscrit
INSD	Diamètre de plaquette
INSL	Longueur de plaquette
KAPR	Angle d'arête de coupe de l'outil
KWD	Profondeur de rainure de clavette
KWW	Largeur de rainure de clavette
L	Longueur de l'arête de coupe
LB	Longueur de corps
LE	Longueur effective de l'arête de coupe
LF	Longueur fonctionnelle
LH	Longueur de la tête
LU	Longueur utile
LUX	Longueur utile maximum
M	Dimension M
NOF	Nombre de goujures



Code ISO 13399	Description
OAL	Longueur totale
P	Pas de tranchant
PRFA	Angle du profil
PRFRAD(2)	Rayon du profil
RE	Rayon
S	Épaisseur de plaquette
S1	Épaisseur totale de plaquette
TDZ	Taille du diamètre du filet
TP	Pas du filetage
TPI	Filets par pouce
W1	Largeur de plaquette
ZNP	Nombre d'arêtes périphériques de l'outil

MATÉRIAUX ET DES REVÊTEMENTS

Matériaux

Acier rapide	HSS	Un acier rapide moyennement allié qui présente une bonne usinabilité et de bonnes performances. L'acier rapide présente des caractéristiques de dureté, de ténacité et de résistance à l'usure qui en font un bon choix pour une large gamme d'applications, notamment pour les forets et les tarauds.
Acier rapide au cobalt	HSS-E	Cet acier rapide contient du cobalt pour une dureté à chaud accrue. La composition du HSCo apporte une bonne combinaison de ténacité et de dureté. Il présente une bonne usinabilité et une bonne résistance à l'usure. Il convient donc à la production de forets, de tarauds, de fraises et d'alésoirs.
Acier rapide au cobalt fritté	HSS-E PM	L'acier rapide au cobalt fritté (HSCo fritté) est un substrat élaboré par métallurgie des poudres. Les outils utilisant des substrats produits selon cette technique présentent une ténacité et une aptitude au meulage élevées.
Carbures (ou matériaux durs)	HM	Substrat fritté de la métallurgie des poudres, constitué d'un composite de carbure métallique avec un métal liant. La matière première essentielle est le carbure de tungstène (WC). C'est lui qui confère sa dureté au matériau. Le carbure de tantale (TaC), le carbure de titane (TiC) et le carbure de niobium (NbC) viennent compléter le carbure de tungstène pour obtenir les propriétés spécifiques recherchées. Ces trois matériaux sont appelés des « carbures cubiques ». Le cobalt (Co) sert de liant et assure donc l'homogénéité du matériau final.

Traitements superficiels/ Revêtements de surface

Brillant (non revêtu)		La finition brillante (surface non revêtue) facilite le glissement des copeaux dans les matériaux non-ferreux ou doux, et conserve le tranchant des arêtes de coupe dans les matériaux abrasifs.
Traitement vapeur		Le traitement vapeur apporte une finition de surface bleue particulièrement adhérente pour retenir le fluide de coupe et éviter que les copeaux ne se collent à l'outil. Il contribue donc à lutter contre la formation d'arêtes rapportées. Le traitement vapeur peut être appliqué sur n'importe quel outil brillant, mais il apporte de meilleurs résultats sur les forets et les tarauds.
Finition de surface brillante polie		La finition de surface brillante facilite le glissement des copeaux dans les matériaux non-ferreux ou doux. Le polissage facilite l'évacuation des copeaux et empêche la matière de coller aux arêtes de coupe et aux goujures.

Revêtement carbonitride de titane (TiCN)		Le carbonitride de titane est un revêtement céramique appliqué par procédé PVD. Le TiCN est plus dur que le TiN et présente un coefficient de frottement plus faible. Sa dureté et sa ténacité, associées à sa bonne résistance à l'usure, confèrent de meilleures performances aux outils du domaine du fraisage.
Revêtements titane aluminium (TiAlN, TiAlN-Top et X-CEED)		Le nitrure de titane aluminium est un revêtement céramique multi-couche appliqué par procédé PVD. Il confère une ténacité et une stabilité à l'oxydation élevées. Ces propriétés en font un matériau idéal pour des vitesses et avances plus élevées, tout en améliorant la durée de vie des outils. Le TiAlN est utilisé dans le perçage, le taraudage et le fraisage. Il peut également convenir aux usinages sans refroidissement. Le revêtement TiAlN-Top est identique au TiAlN, mais il subit un traitement après revêtement pour lisser les imperfections, favoriser l'écoulement des copeaux et réduire la formation d'arêtes rapportées. Le revêtement TiAlN de type X-CEED, également connu sous le nom de revêtement FUTURA NANO, est un revêtement nanocouche conçu pour des applications de dureté à chaud et de contraintes plus élevées.
Revêtement aluminium nitrure de titane (AlTiN)		Le revêtement aluminium nitrure de titane (AlTiN) est une évolution améliorée des revêtements TiAlN conventionnels. Il apporte une ténacité supérieure et une dureté à chaud et une résistance à l'oxydation élevées.
Revêtement Alcrona (AlCrN, Alcrona, Alcrona-Top et Alcrona-Pro)		Les revêtements de la famille Alcrona (AlCrN) sont en nitrure de chrome aluminium ; ils sont principalement utilisés pour les fraises. Les deux propriétés spécifiques de ces revêtements sont une grande dureté à chaud et une résistance à l'oxydation élevée. Appliquées aux outils destinés à des usinages sous fortes contraintes mécaniques et thermiques, ces propriétés se traduisent par une résistance supérieure à l'usure. Plusieurs niveaux ou versions particulières de ces revêtements sont disponibles pour divers outils et applications.
Revêtement nitrure de silicium titane (TiSiN)		Le TiSiN est conçu pour les conditions de coupe extrêmes et l'usinage grande vitesse de matériaux durs. Ce revêtement multi-couche comporte une couche extérieure nanocomposite avec des nanocristallites de Si ₃ N ₄ dans une matrice cristalline de TiN. Il est conçu pour protéger le tranchant contre le transfert de chaleur, l'oxydation et l'abrasion. Les revêtements TiSiN sont performants même dans des conditions de lubrification minimales ou nulles.
Revêtement type diamant (DLC)		Le revêtement de type diamant, ou DLC, apporte un pouvoir lubrifiant exceptionnel sur les outils en carbure et évite la formation d'arêtes rapportées lors de l'usinage du graphite ou de matériaux non ferreux tendres.

INFORMATIONS TECHNIQUES – FRAISAGE

Nomenclature

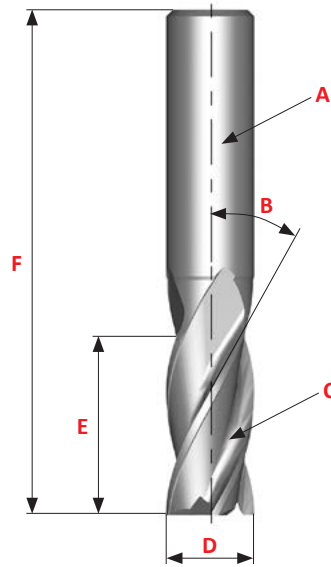

- A** Queue
- B** Angle d'hélice
- C** Goujure
- D** Diamètre extérieur *DC*
- E** Longueur de coupe *AP*
- F** Longueur totale *OAL*

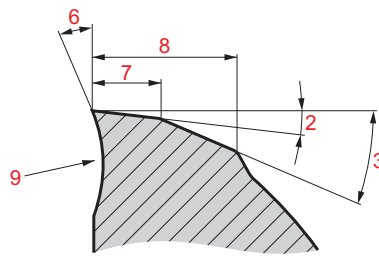
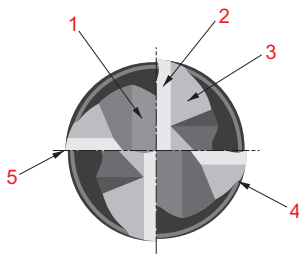

- 1** Entre-dents
- 2** Angle de dépouille primaire
- 3** Angle de contre-dépouille
- 4** Listel
- 5** Arête de coupe
- 6** Angle de coupe
- 7** Largeur de dépouille
- 8** Largeur de contre-dépouille
- 9** Contre-facette

Caractéristiques de la fraise – Choix du nombre de goujures *NOF*

Le choix du nombre de goujures est fonction des éléments suivants:

- matière usinée,
- dimensions de la pièce usinée,
- conditions d'usinage.

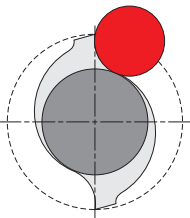
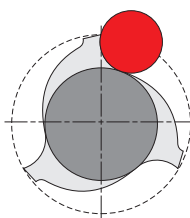
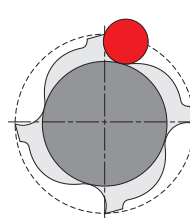
2 goujures	3 goujures	4 goujures (ou plus)
		
FAIBLE	FORCE FLÉCHISSEMENT	ÉLEVÉE
GRAND	ESPACE ENTRE-DENTS	PETIT
<ul style="list-style-type: none"> • Grand espace entre-dents • Évacuation facile des copeaux • Convient au rainurage • Convient au fraisage lourd • Section réduite qui affaiblit la rigidité • Moindre qualité de surface 	<ul style="list-style-type: none"> • Espace entre-dents pratiquement équivalent à 2 goujures • Section plus large offrant une plus grande rigidité que 2 goujures • Finition de surface améliorée 	<ul style="list-style-type: none"> • Rigidité supérieure • Section la plus large, espace entre-dents réduit • La meilleure finition de surface • Recommandé pour le profilage, le fraisage périphérique et le rainurage peu profond

INFORMATIONS TECHNIQUES – FRAISAGE

Caractéristiques des fraises – Angle d'hélice

L'augmentation du nombre de goujures améliore la répartition de charge sur la dent, ce qui permet d'obtenir une meilleure finition. Mais un angle d'hélice élevé a aussi pour conséquence d'accroître la charge *FV* le long de l'axe de la fraise.

Une charge *FV* élevée peut provoquer:

- des problèmes de contraintes sur les roulements de la broche,
- un mouvement de la fraise le long de l'axe de la broche. Pour éviter cela, il est nécessaire d'utiliser des porte-outils Weldon ou, de préférence, mécaniques ou hydrauliques.



Définition générale du fraisage

Le fraisage est un procédé d'usinage permettant de réaliser des surfaces par enlèvement progressif d'une certaine quantité de matière de la pièce grâce à une vitesse de déplacement ou d'avance relativement lente et à une rotation de la fraise tournant à une vitesse comparativement élevée.

La caractéristique principale du procédé de fraisage est l'enlèvement de matière sous forme de copeaux individuels par chaque dent.

Types de fraises

Les trois opérations de fraisage de base sont décrites ci-dessous: **(A)** fraisage périphérique, **(B)** surfaçage, **(C)** fraisage en bout.

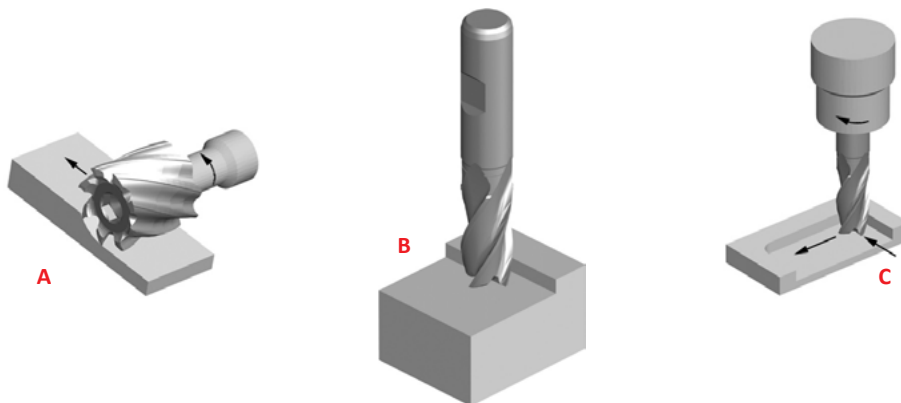

Lors du fraisage périphérique (ou fraisage en roulant), l'axe de rotation de la fraise est parallèle à la surface de la pièce à usiner. La fraise a un certain nombre de dents sur sa circonférence, chaque dent agissant en un seul point comme les outils coupants appelés fraises une taille.

Les fraises utilisées en fraisage périphérique peuvent avoir une denture droite ou hélicoïdale réalisant une action de coupe orthogonale ou oblique.





Lors du surfaçage, la fraise est montée sur une broche avec un axe de rotation perpendiculaire à la surface de la pièce usinée. La surface fraisée résulte d'une action des arêtes de coupe situées sur la périphérie ou le bout de la fraise.

Lors du fraisage en bout, la fraise tourne généralement sur un axe vertical par rapport à la pièce usinée. Elle peut être inclinée pour usiner des surfaces coniques. Les dents de coupe se situent à la fois sur le bout de la fraise et sur la périphérie du corps de la fraise.

INFORMATIONS TECHNIQUES – FRAISAGE

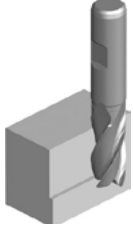
Applications

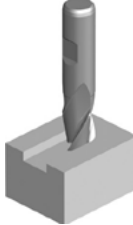
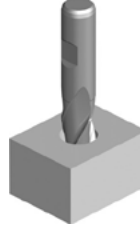
Le TEM (Taux d'enlèvement de matière) et les applications sont extrêmement liés. Pour chaque type d'application il peut y avoir différents TEM qui augmentent selon l'engagement de la fraise dans la pièce usinée. Le catalogue Dormer Pramet contient des icônes décrivant les différentes applications.

Contournage	Fraisage en bout	Rainurage	Tréflage	Ramping
				
La profondeur radiale de la coupe doit être inférieure à 0.25 du diamètre de la fraise.	La profondeur radiale de coupe ne doit pas dépasser 0.9 du diamètre, la profondeur axiale inférieure à 0.1 du diamètre.	Usinage d'une rainure de clavette. La profondeur radiale est égale au diamètre de la fraise.	Il est possible de percer la pièce usinée avec une fraise de finition en se servant simplement de la coupe au centre. Dans cette opération l'avance doit être divisée par deux.	Entrée à la fois axiale et radiale dans la pièce usinée.

Un fraisage efficace

Types de coupes

Fraisage en avalant et fraisage en opposition

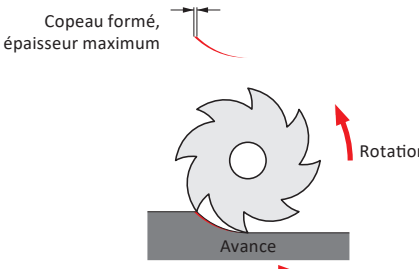
FRAISAGE EN AVALANT	FRAISAGE EN OPPOSITION
 <p>Copeau formé, épaisseur maximum</p> <p>Rotation</p> <p>Avance</p>	 <p>Début copeau, épaisseur zéro</p> <p>Rotation</p> <p>Avance</p>

En fraisage en avalant, la fraise tourne dans le même sens que l'avance de la table. La dent rencontre la pièce à usiner en haut de la coupe, produisant d'abord la partie la plus épaisse du copeau. Dans les applications horizontales, la force produite par le fraisage en avalant peut agir comme force de serrage, vers la table de la machine. Il est important de s'assurer que la vis principale de la machine-outil n'a pas de jeu. En condition normale, le fraisage en avalant améliore l'état de surface de la pièce et augmente la durée de vie de l'outil.

En fraisage en opposition, la fraise tourne dans le sens opposé de l'avance de la table. Par conséquent, la largeur du copeau commence à zéro et augmente jusqu'à son maximum, en fin de coupe. Dans certains cas, ce processus peut accélérer l'usure de l'outil. Le fraisage en opposition peut s'avérer avantageux sur l'acier laminé à chaud, l'acier trempé en surface et des aciers présentant une calamine en surface.

FRAISAGE PÉRIPHÉRIQUE (UNE TAILLE, CYLINDRIQUE)

Fraisage périphérique: Fraisage d'une surface parallèle à l'axe de la fraise.

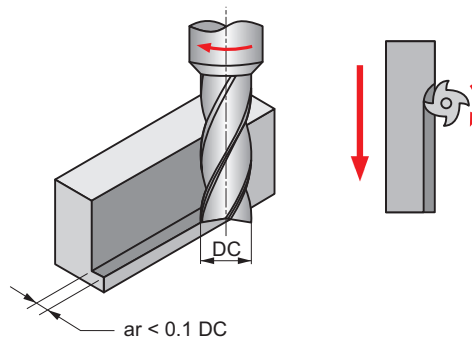

La profondeur de coupe radiale doit mesurée moins de 0.1 du diamètre de la fraise: $ar < 0.1 DC$.



INFORMATIONS TECHNIQUES – FRAISAGE

Tréflage

Mouvement direct entre la pièce usinée et l'axe de la fraise lorsque la fraise plonge directement dans la pièce.

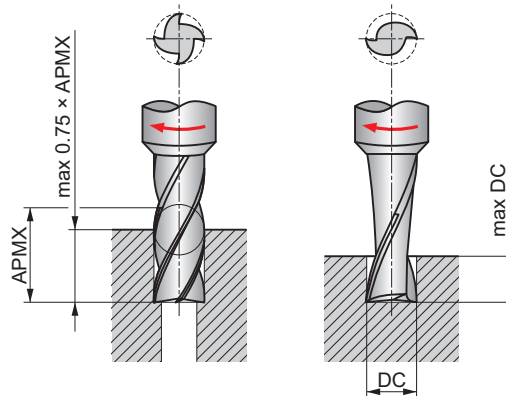

Pour pouvoir «percer» (c'est-à-dire fraiser avec une avance axiale), l'arête de coupe d'une fraise en bout doit courir jusqu'au centre. Exemple: fraissage d'une rainure de clavette au milieu d'un axe.

En alésage, la profondeur du trou peut atteindre 75 % de la longueur de l'arête de coupe. En perçage en pleine matière, elle ne doit pas dépasser 0.5 – 1.0 DC.

Rainurage

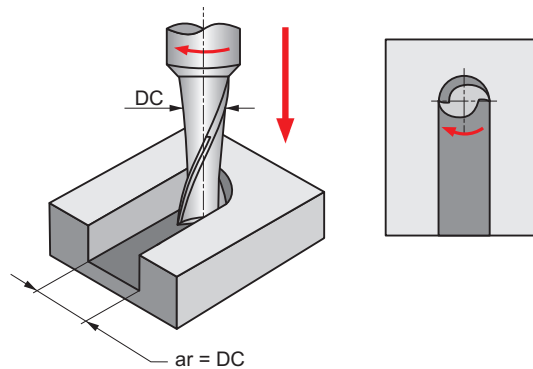

La profondeur de coupe radiale est égale au diamètre de la fraise: $ar = DC$.

Toutes les applications de rainurage sont une combinaison de fraissage conventionnel et de fraissage en avalant. Voir la section suivante.

Choix d'une fraise en bout

Utiliser l'outil le plus court possible pour l'application, avec le plus grand diamètre possible et la longueur de goujure la plus courte possible en fonction de la profondeur de coupe. Les fraises en bout extra-longues présentent un porte-à-faux excessif qui peut nécessiter jusqu'à 25 % de réduction de l'avance. Les fraises extra-courtes, du fait de leur longueur totale et de leur longueur de goujure réduites, sont plus rigides. Elles peuvent donc nécessiter une vitesse d'avance jusqu'à 25 % plus rapide.

Vitesses

Les fraises en bout en carbure monobloc doivent être utilisées à des vitesses plus élevées que celles en acier rapide. Souvent, des passes plus légères à des vitesses plus élevées peuvent améliorer la finition de la pièce usinée.

En rainurage, la vitesse doit être réduite de 20 % environ. Les vitesses doivent également être réduites lors du fraissage de matériaux durs ou tenaces, ou en usinage lourd. Les vitesses peuvent être accélérées dans les matériaux plus tendres ou avec des passes plus légères. Les vitesses doivent également être augmentées pour les coupes de finition.

Fluides de coupe

L'utilisation d'un fluide de coupe est recommandée pour le fraissage des aciers doux et des alliages haute température. Le fluide de coupe a pour objectif d'évacuer les copeaux loin de l'outil et de la pièce usinée. Cela évite d'endommager les arêtes de coupe en recoupant (ou recyclant) les copeaux. Lors de l'usinage du titane, le flux du liquide de refroidissement doit être important et dirigé vers la zone de coupe pour éviter la surchauffe et faciliter l'évacuation des copeaux.

FRAISES HSS – TABLEAU DES AVANCES PAR DENT (EN MM)

1 APMX FFW = 0.5×DC
 APMX EFW = DC

2 APMX FFW = 1×DC
 APMX EFW ≥ 0.5×DC

3 APMX FFW = 0.5×DC
 APMX EFW = DC

Avance par dent (f_z en mm/dent).
 Ajuster ces valeurs de ±25 % selon les conditions de travail.
 Pour le tréflage dans un matériau plein avec une fraise à coupe au centre, et **UNIQUEMENT** dans ce cas, considérer les valeurs de ce tableau en f_n (avance par tour).

Comment trouver l'avance par dent f_z grâce à ce tableau :

1. Rechercher le code Alpha sur la page produit (par ex. 48C, « C » étant le code Alpha).
2. Trouver le diamètre le plus proche de celui recherché pour votre application (première ligne du tableau).
3. Rechercher votre code Alpha dans la colonne gauche du tableau.
4. La cellule à l'intersection de la colonne Diamètre et de la ligne code Alpha indique l'avance par dent f_z .

**FRAISES HSS,
HSS-E ET HSS-E-PM
UNIQUEMENT**

		ø DC (mm)																		
		1.00	2.00	3.00	4.00	5.00	6.00	8.00	10.0	12.0	16.0	20.0	25.0	28.0	32.0	36.0	40.0	63.0	80.0	100.0
Avances (mm/dent)	A	0.002	0.003	0.003	0.005	0.005	0.005	0.007	0.009	0.011	0.015	0.018	0.023	0.027	0.030	0.033	0.034	0.043	0.045	0.042
	B	0.003	0.004	0.004	0.006	0.006	0.007	0.009	0.012	0.014	0.018	0.023	0.029	0.033	0.038	0.041	0.043	0.054	0.057	0.052
	C	0.004	0.004	0.005	0.007	0.008	0.008	0.011	0.015	0.017	0.023	0.029	0.036	0.042	0.047	0.051	0.054	0.067	0.071	0.065
	D	0.005	0.006	0.006	0.009	0.010	0.010	0.014	0.018	0.022	0.029	0.036	0.045	0.052	0.059	0.064	0.067	0.084	0.089	0.082
	E	0.006	0.007	0.008	0.011	0.012	0.013	0.017	0.023	0.027	0.036	0.045	0.056	0.065	0.074	0.080	0.084	0.105	0.111	0.102
	F	0.007	0.008	0.010	0.013	0.014	0.016	0.020	0.028	0.032	0.043	0.054	0.067	0.078	0.089	0.096	0.101	0.126	0.133	0.122
	G	0.009	0.010	0.012	0.016	0.017	0.019	0.024	0.033	0.039	0.052	0.065	0.081	0.094	0.107	0.115	0.121	0.151	0.160	0.147
	H	0.010	0.012	0.014	0.019	0.021	0.022	0.029	0.040	0.047	0.062	0.078	0.097	0.112	0.128	0.138	0.145	0.181	0.192	0.176
	I	0.012	0.015	0.017	0.023	0.025	0.027	0.035	0.048	0.056	0.075	0.093	0.116	0.135	0.153	0.166	0.174	0.218	0.230	0.212
	J	0.015	0.017	0.020	0.027	0.030	0.032	0.042	0.057	0.067	0.090	0.112	0.139	0.162	0.184	0.199	0.209	0.261	0.276	0.254

Ce tableau s'applique aux fraises en bout et fraises deux tailles.

Formules (mm)		Termes		Formules (pouces)	
$v_c = \frac{n \times DC \times \pi}{1000}$	v_c	(m/min)	Vitesse de coupe	SFM	(pied/min)
	n	(tr/min)	Vitesse de rotation de l'axe	RPM	(tr/min)
$n = \frac{v_c \times 1000}{DC \times \pi}$	V_f	(mm/min)	Avance	IPM	(pouce/min)
	f_z	(mm/dent)	Avance par dent	IPT	(pouce/dent)
$V_f = f_z \times z \times n$	DC	(mm)	Diamètre de coupe	DC	(po)
$f_z = \frac{V_f}{z \times n}$	z	(-)	Nombre de dents	T	(-)
$Q = \frac{V_f \times a_p \times a_e}{1000}$	a_p	(mm)	Profondeur de coupe	DOC	(po)
	a_e	(mm)	Largeur de coupe	WOC	(po)
	Q	(cm ³ /min)	Taux d'enlèvement de métal	MRR	(po ³ /min)
				$SFM = \frac{RPM \times DC \times \pi}{12}$	
				$RPM = \frac{SFM \times 12}{DC \times \pi}$	
				$IPM = IPT \times T \times RPM$	
				$IPT = \frac{IPM}{T \times RPM}$	
				$MRR = IPM \times DOC \times WOC$	

FRAISES HSS – TABLEAU DES AVANCES PAR DENT (EN POUCE)

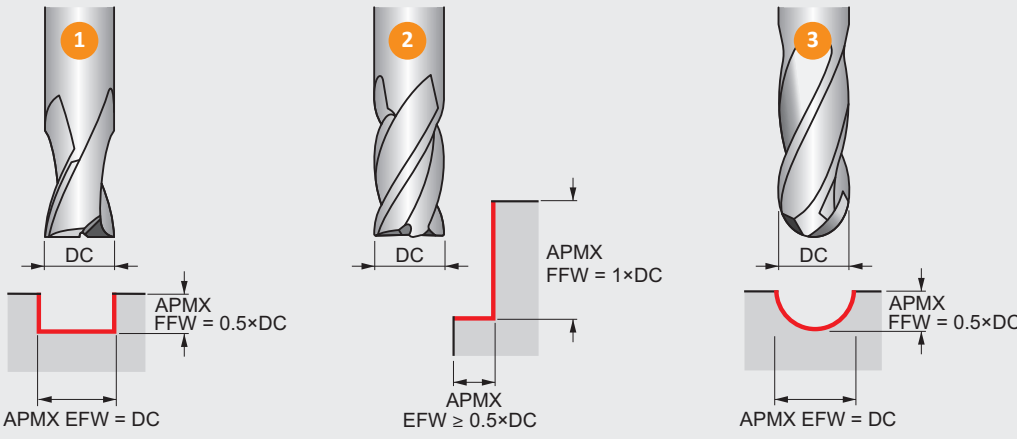

Avance par dent (*IP*T ou pouce/dent).
Ajuster ces valeurs de $\pm 25\%$ selon les conditions de travail.

Pour le tréflage dans un matériau plein avec une fraise à coupe au centre, et **UNIQUEMENT** dans ce cas, considérer les valeurs de ce tableau en *IP*R (avance par pouce par tour).

Comment trouver l'avance par dent *IP*T grâce à ce tableau :

1. Rechercher le code Alpha sur la page produit (par ex. 157C, « C » étant le code Alpha).
2. Trouver le diamètre le plus proche de celui recherché pour votre application (première ligne du tableau).
3. Rechercher votre code Alpha dans la colonne gauche du tableau.
4. La cellule à l'intersection de la colonne Diamètre et de la ligne code Alpha indique l'avance par dent *IP*T.

**FRAISES HSS,
HSS-E ET HSS-E-PM
UNIQUEMENT**



		ø DC (pouce)																		
		1/16	3/32	1/8	5/32	3/16	7/32	1/4	5/16	3/8	7/16	1/2	9/16	5/8	3/4	7/8	1	1 1/8	1 1/4	1 1/2
		.0625	.0938	.1250	.1563	.1875	.2188	.2500	.3125	.3750	.4375	.5000	.5625	.6250	.7500	.8750	1.0000	1.1250	1.2500	1.5000
Avances (pouce/dent)	A	.0001	.0001	.0001	.0002	.0002	.0002	.0002	.0003	.0004	.0004	.0005	.0006	.0006	.0007	.0008	.0009	.0011	.0012	.0013
	B	.0001	.0002	.0002	.0002	.0002	.0002	.0003	.0004	.0004	.0005	.0006	.0007	.0007	.0009	.0011	.0012	.0014	.0015	.0017
	C	.0002	.0002	.0002	.0003	.0003	.0003	.0004	.0004	.0005	.0006	.0007	.0008	.0009	.0011	.0013	.0015	.0017	.0019	.0020
	D	.0002	.0002	.0002	.0004	.0004	.0004	.0004	.0006	.0007	.0008	.0009	.0010	.0011	.0013	.0017	.0019	.0021	.0023	.0026
	E	.0002	.0003	.0003	.0004	.0005	.0005	.0006	.0007	.0008	.0010	.0011	.0013	.0014	.0017	.0020	.0023	.0027	.0029	.0032
	F	.0003	.0003	.0004	.0005	.0006	.0006	.0007	.0008	.0010	.0012	.0014	.0016	.0017	.0020	.0024	.0028	.0032	.0035	.0039
	G	.0004	.0004	.0005	.0006	.0007	.0007	.0008	.0009	.0012	.0014	.0017	.0019	.0020	.0024	.0030	.0033	.0039	.0042	.0046
	H	.0004	.0005	.0006	.0007	.0008	.0008	.0009	.0011	.0014	.0017	.0020	.0022	.0024	.0029	.0035	.0040	.0046	.0050	.0056
	I	.0005	.0006	.0007	.0009	.0010	.0010	.0011	.0014	.0017	.0020	.0024	.0027	.0030	.0035	.0043	.0048	.0056	.0060	.0067
	J	.0006	.0007	.0008	.0011	.0012	.0012	.0014	.0017	.0020	.0024	.0028	.0032	.0035	.0042	.0051	.0058	.0067	.0072	.0080

Ce tableau s'applique aux fraises en bout et fraises deux tailles.

FRAISES HSS – FACTEURS DE CORRECTION



1 Rainurage

Facteurs de correction de la vitesse de coupe v_c et de l'avance par dent f_z pour les opérations de rainurage à différentes profondeurs de coupe.

APMX FFW / DC	25 %	50 %	100 %	150 %
	1.25	1.00	0.75	0.50
	1.25	1.00	0.75	0.50

2 Fraisage d'épaulements

Facteurs de correction de la vitesse de coupe v_c et de l'avance par dent f_z pour le surfacage-dressage avec un engagement radial de < 50 %.

APMX EFW / DC	5 %	10 %	15 %	20 %	25 %	30 %	40 %	≥ 50 %
	1.48	1.35	1.27	1.22	1.19	1.16	1.11	1.00
	2.29	1.67	1.40	1.25	1.15	1.09	1.02	1.00

Nous recommandons d'éviter le fraisage avec un engagement radial de 50 %.

3a Surfaçage (avec des fraises à bout sphérique)

Facteurs de correction de la vitesse de coupe v_c pour le surfacage par copiage à différentes profondeurs de coupe.

APMX FFW / DC	5 %	10 %	15 %	20 %	25 %	30 %	40 %	50 %
	2.29	1.67	1.40	1.25	1.15	1.09	1.02	1.00

3b

Décalage f_e (distance de chevauchement) pour atteindre une rugosité de surface théorique R_{th} .

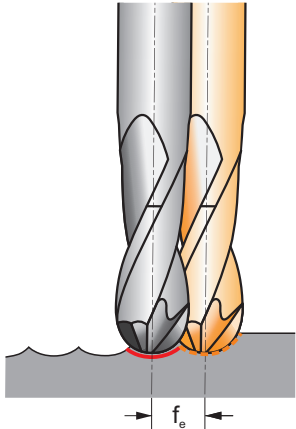
DC	μm	2	4	8	16	32	63	125	250
2		0.13	0.18	0.25	0.36	0.50	0.70	0.97	1.32
3		0.15	0.22	0.31	0.44	0.62	0.86	1.20	1.66
4		0.18	0.25	0.36	0.50	0.71	1.00	1.39	1.94
5		0.20	0.28	0.40	0.56	0.80	1.12	1.56	2.18
6		0.22	0.31	0.44	0.62	0.87	1.22	1.71	2.40
8		0.25	0.36	0.51	0.71	1.01	1.41	1.98	2.78
10		0.28	0.40	0.57	0.80	1.13	1.58	2.22	3.12
12		0.31	0.44	0.62	0.88	1.24	1.73	2.44	3.43
14		0.33	0.47	0.67	0.95	1.34	1.87	2.63	3.71
16		0.36	0.51	0.72	1.01	1.43	2.00	2.82	3.97
18		0.38	0.54	0.76	1.07	1.52	2.13	2.99	4.21
20		0.40	0.57	0.80	1.13	1.60	2.24	3.15	4.44
22		0.42	0.59	0.84	1.19	1.68	2.35	3.31	4.66
25	0.45	0.63	0.89	1.26	1.79	2.51	3.53	4.97	
28	0.47	0.67	0.95	1.34	1.89	2.65	3.73	5.27	

Les dimensions de décalage sont affichées en mm uniquement.

FRAISES HSS – FACTEURS DE CORRECTION

3c

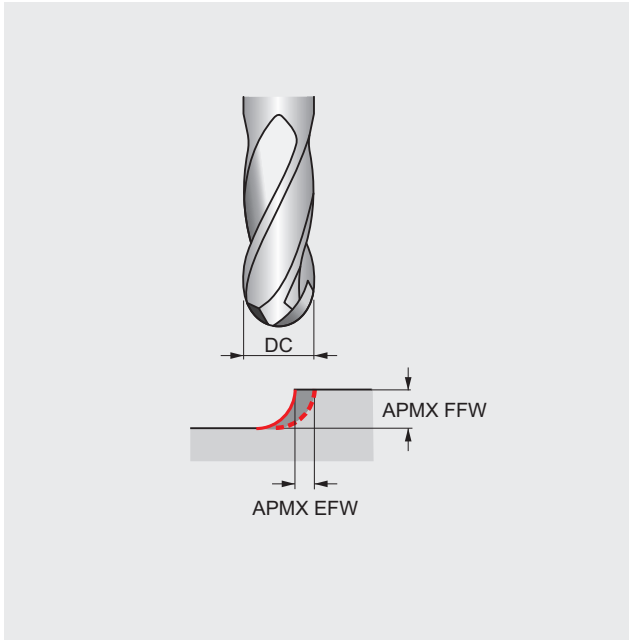

Comment trouver le facteur de correction de l'avance par dent (f_z ou IPT) pour le surfacage par copiage :

1. Trouver l'immersion radiale (a_e / DC) la plus proche de celle recherchée pour votre application (première ligne du tableau).
3. Trouver l'immersion axiale (a_p / DC) la plus proche de celle recherchée pour votre application (colonne gauche du tableau).
4. La cellule à l'intersection des immersions radiale et axiale indique le facteur de correction pour l'avance par dent.

Exemple de surfacage par copiage :

1. Utilisation d'une fraise à bout sphérique de 8 mm à une profondeur de coupe de 0.8 mm (a_p) pour atteindre une rugosité de surface théorique de 32 μm .
2. Le facteur de correction de la vitesse de coupe avec une immersion axiale de 10 % = 1.67 (tableau 3a).
3. La distance de chevauchement pour une R_{th} de 32 μm = 1.01 mm (tableau 3b).
4. Le facteur de correction pour une avance par dent avec une immersion axiale de 10 % et une immersion radiale de 1.01 / 8 = 12.6 % est ici de 2.33 (tableau 3c).

Facteurs de correction de l'avance par dent f_z pour le surfacage par copiage avec un décalage < 50 % $\times DC$ à différentes profondeurs de coupe.

APMX FFW	APMX EFW	5%	10%	15%	20%	25%	30%	35%	40%	50%
5%		5.26	3.82	3.21	2.87	2.65	2.50	2.40	2.34	2.29
10%		3.82	2.78	2.33	2.08	1.92	1.82	1.75	1.70	1.67
15%		3.21	2.33	1.96	1.75	1.62	1.53	1.47	1.43	1.40
20%		2.87	2.08	1.75	1.56	1.44	1.36	1.31	1.28	1.25
25%		2.65	1.92	1.62	1.44	1.33	1.26	1.21	1.18	1.15
30%		2.50	1.82	1.53	1.36	1.26	1.19	1.14	1.11	1.09
35%		2.40	1.75	1.47	1.31	1.21	1.14	1.10	1.07	1.05
40%		2.34	1.70	1.43	1.28	1.18	1.11	1.07	1.04	1.02
45%		2.31	1.68	1.41	1.26	1.16	1.10	1.05	1.03	1.01
50%		2.29	1.67	1.40	1.25	1.15	1.09	1.05	1.02	1.00

Pour améliorer la qualité de surface, il est possible d'incliner l'outil ou la surface de 10° – 15°.

FRAISES HSS DE FORME – TABLEAU DES AVANCES PAR DENT

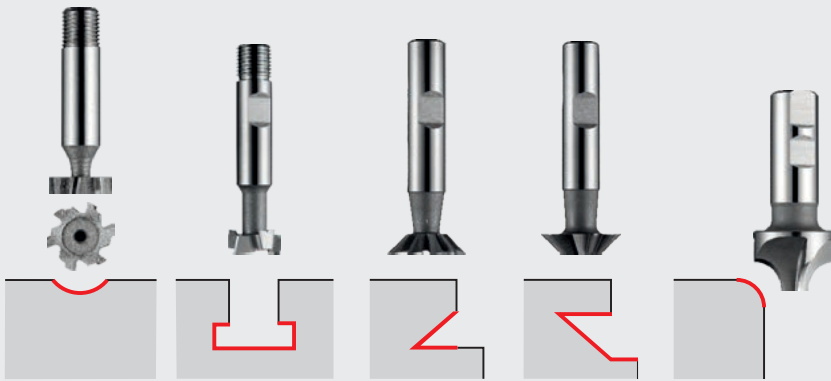

Avance par dent f_z (mm).
Ajuster ces valeurs de $\pm 25\%$ selon les conditions de travail.

Comment trouver l'avance par dent f_z grâce à ce tableau :

1. Rechercher le code Alpha sur la page produit (par ex. 40V, « V » étant le code Alpha).
2. Trouver le diamètre le plus proche de celui recherché pour votre application (première ligne du tableau).
3. Rechercher votre code Alpha dans la colonne gauche du tableau.
4. La cellule à l'intersection de la colonne Diamètre et de la ligne code Alpha indique l'avance par dent f_z .

Avances pour les fraises : C800, C801, C810, C820, C822, C825, C830, C835, C837, C831, C700, C710, D745, D747, D750, D751, D752, D753, D200, D763.

		ø DC (mm)															
		10.0	12.0	16.0	20.0	25.0	32.0	38.0	50.0	63.0	80.0	100.0	125.0	160.0	200.0	300.0	350.0
Avances (mm)	P	–	–	–	–	–	0.200	–	0.200	0.200	0.200	0.200	0.200	0.200	0.200	0.200	0.200
	Q	–	–	–	–	–	0.040	–	0.040	0.040	0.040	0.040	0.040	0.040	0.040	0.040	0.040
	R	–	–	–	–	–	0.600	–	0.600	0.600	0.600	0.600	0.600	0.600	0.600	0.600	0.600
	S	0.020	0.020	0.020	0.040	0.040	0.040	0.040	0.050	0.050	0.060	0.070	0.080	0.090	0.100	0.100	0.100
	T	0.020	0.020	0.030	0.050	0.050	0.050	0.060	0.060	0.060	–	–	–	–	–	–	–
	U	0.030	0.030	0.030	0.050	0.060	0.060	0.060	0.060	0.060	–	–	–	–	–	–	–
	V	0.030	0.030	0.040	0.060	0.060	0.060	0.070	0.070	0.070	0.080	0.090	0.100	0.110	0.120	0.120	0.120
	W	0.040	0.050	0.050	0.060	0.060	0.070	0.070	0.070	0.070	0.090	0.100	0.110	0.110	0.120	0.120	0.120
	X	0.050	0.050	0.060	0.070	0.080	0.100	0.110	0.110	0.110	0.110	0.110	0.120	0.130	0.140	0.140	0.140
	Y	0.060	0.060	0.070	0.090	0.100	0.110	0.130	0.130	–	–	–	–	–	–	–	–
Z	0.070	0.070	0.090	0.110	0.120	0.110	0.150	–	–	–	–	–	–	–	–	–	

Avances f_z affichées en mm uniquement.

FRAISES HSS TYPE SCIE – TABLEAUX DE SÉLECTION DU PAS DE DENT

Sélection du pas de dent pour les fraises-scies D750, D751, D752, D753

		Tube plein							
		Pas (P)							
		2.5	3	4	5	6	8		
Diamètre (t)	4		P	M	N	K			
	6			P	M	N	K		
	8				P	M	N	K	
	10				P	M	N	K	
	15					P	M	N	K
	20					P	M	N	K
	30							P	M
	40								P
60									

P ISO P = groupe de matériaux à usiner (WMG) Acier
M ISO M = groupe de matériaux à usiner (WMG) Acier inoxydable

		Profils et tubes								
		Pas (P)								
		2.5	3	4	5	6	8			
Épaisseur paroi (t)	1		P	M	N	K				
	1.5			P	M	N	K			
	2				P	M	N	K		
	3					P	M	N	K	
	> 4						P	M	N	K

K ISO K = groupe de matériaux à usiner (WMG) Fonte
N ISO N = groupe de matériaux à usiner (WMG) Métaux non ferreux

FRAISES CARBURE – TABLEAU DES AVANCES PAR DENT (EN MM)

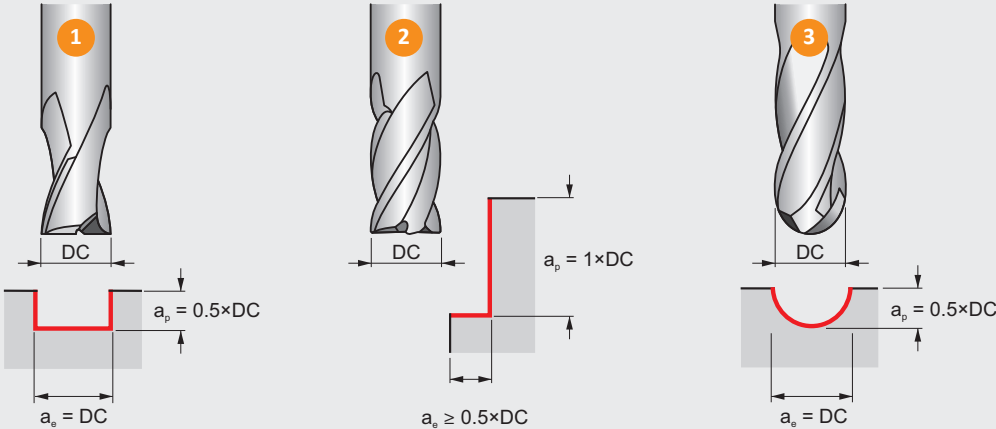

Avance par dent f_z (mm).
Ajuster ces valeurs de $\pm 25\%$ selon les conditions de travail.

Pour le tréflage dans un matériau plein avec une fraise à coupe au centre, et **UNIQUEMENT** dans ce cas, considérer les valeurs de ce tableau en f_n (avance par tour).

Comment trouver l'avance par dent f_z grâce à ce tableau :

1. Rechercher le code Alpha sur la page produit (par ex. 199K, « K » étant le code Alpha).
2. Trouver le diamètre le plus proche de celui recherché pour votre application (première ligne du tableau).
3. Rechercher votre code Alpha dans la colonne gauche du tableau.
4. La cellule à l'intersection de la colonne Diamètre et de la ligne code Alpha indique l'avance par dent f_z .

**FRAISES CARBURE
MONOBLOCS
UNIQUEMENT**

		\varnothing DC (mm)																
		1.00	2.00	3.00	4.00	5.00	6.00	7.00	8.00	9.00	10.0	12.0	14.0	16.0	18.0	20.0	22.0	25.0
Avances (mm)	A	0.002	0.003	0.004	0.005	0.006	0.007	0.008	0.009	0.010	0.011	0.014	0.015	0.017	0.019	0.021	0.025	0.028
	B	0.002	0.003	0.004	0.005	0.006	0.007	0.008	0.009	0.010	0.011	0.014	0.015	0.017	0.019	0.021	0.025	0.028
	C	0.002	0.003	0.004	0.005	0.006	0.007	0.008	0.009	0.010	0.011	0.014	0.015	0.017	0.019	0.021	0.025	0.028
	D	0.002	0.003	0.004	0.005	0.007	0.008	0.009	0.010	0.011	0.012	0.014	0.015	0.017	0.019	0.021	0.025	0.028
	E	0.002	0.003	0.004	0.008	0.009	0.012	0.013	0.014	0.015	0.016	0.019	0.021	0.024	0.026	0.028	0.030	0.034
	F	0.002	0.003	0.006	0.010	0.013	0.016	0.017	0.019	0.021	0.022	0.026	0.029	0.032	0.035	0.039	0.042	0.047
	G	0.002	0.005	0.008	0.014	0.018	0.022	0.024	0.026	0.028	0.031	0.035	0.040	0.044	0.048	0.053	0.057	0.064
	I	0.003	0.006	0.011	0.019	0.024	0.030	0.032	0.036	0.039	0.042	0.049	0.054	0.061	0.066	0.073	0.079	0.088
	J	0.004	0.009	0.014	0.026	0.033	0.041	0.044	0.048	0.053	0.057	0.066	0.074	0.083	0.090	0.099	0.107	0.120
	K	0.006	0.012	0.019	0.035	0.044	0.054	0.059	0.064	0.070	0.076	0.088	0.098	0.110	0.120	0.132	0.142	0.160
	N	0.008	0.016	0.025	0.047	0.058	0.072	0.078	0.086	0.094	0.101	0.117	0.131	0.146	0.160	0.175	0.189	0.212
	O	0.010	0.021	0.034	0.062	0.078	0.096	0.104	0.114	0.124	0.135	0.156	0.174	0.195	0.213	0.233	0.252	0.283
	P	0.014	0.028	0.045	0.083	0.104	0.128	0.138	0.152	0.166	0.180	0.207	0.231	0.259	0.283	0.311	0.335	0.376
	R	0.018	0.037	0.060	0.110	0.138	0.170	0.184	0.202	0.221	0.239	0.276	0.308	0.345	0.377	0.414	0.446	0.501
	S	0.024	0.049	0.080	0.147	0.183	0.226	0.245	0.269	0.294	0.318	0.367	0.410	0.459	0.502	0.550	0.593	0.667

Formules (mm)		Termes		Formules (pouces)	
$v_c = \frac{n \times DC \times \pi}{1000}$	v_c	(m/min)	Vitesse de coupe	SFM	(pied/min)
	n	(tr/min)	Vitesse de rotation de l'axe	RPM	(tr/min)
$n = \frac{v_c \times 1000}{DC \times \pi}$	V_f	(mm/min)	Avance	IPM	(pouce/min)
	f_z	(mm/dent)	Avance par dent	IPT	(pouce/dent)
$V_f = f_z \times z \times n$	DC	(mm)	Diamètre de coupe	DC	(po)
$f_z = \frac{V_f}{z \times n}$	z	(-)	Nombre de dents	T	(-)
$Q = \frac{V_f \times a_p \times a_e}{1000}$	a_p	(mm)	Profondeur de coupe	DOC	(po)
	a_e	(mm)	Largeur de coupe	WOC	(po)
	Q	(cm ³ /min)	Taux d'enlèvement de métal	MRR	(po ³ /min)
				$SFM = \frac{RPM \times DC \times \pi}{12}$	
				$RPM = \frac{SFM \times 12}{DC \times \pi}$	
				$IPM = IPT \times T \times RPM$	
				$IPT = \frac{IPM}{T \times RPM}$	
				$MRR = IPM \times DOC \times WOC$	

FRAISES CARBURE – TABLEAU DES AVANCES PAR DENT (EN POUCE)

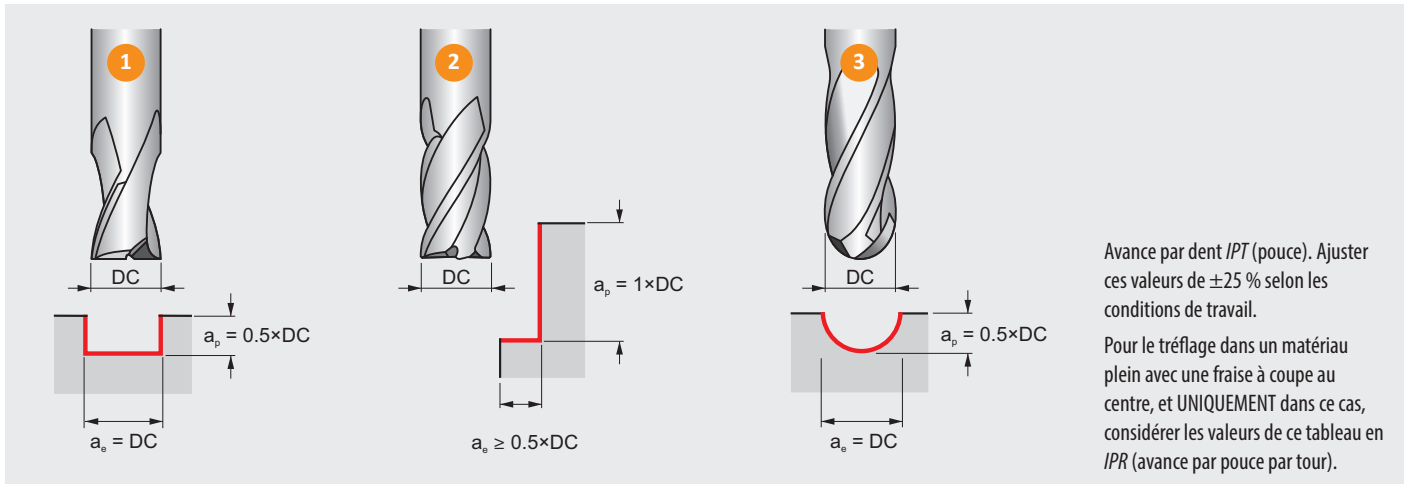

Comment trouver l'avance par dent *IPR* grâce à ce tableau :

1. Rechercher le code Alpha sur la page produit (par ex. 653K, « K » étant le code Alpha).
2. Trouver le diamètre le plus proche de celui recherché pour votre application (première ligne du tableau).
3. Rechercher votre code Alpha dans la colonne gauche du tableau.
4. La cellule à l'intersection de la colonne Diamètre et de la ligne code Alpha indique l'avance par dent *IPR*.



**FRAISES CARBURE
MONOBLOCS
UNIQUEMENT**

		ø DC (pouce)															
		1/16	3/32	1/8	5/32	3/16	7/32	1/4	5/16	3/8	7/16	1/2	9/16	5/8	3/4	7/8	1
		.0625	.0938	.1250	.1563	.1875	.2188	.2500	.3125	.3750	.4375	.5000	.5625	.6250	.7500	.8750	1.0000
Avances (pouce)	A	.0001	.0001	.0002	.0002	.0002	.0002	.0003	.0003	.0004	.0005	.0005	.0006	.0007	.0008	.0010	.0011
	B	.0001	.0001	.0002	.0002	.0002	.0002	.0003	.0003	.0004	.0005	.0005	.0006	.0007	.0008	.0010	.0011
	C	.0001	.0001	.0002	.0002	.0002	.0002	.0003	.0003	.0004	.0005	.0005	.0006	.0007	.0008	.0010	.0011
	D	.0001	.0001	.0002	.0002	.0002	.0003	.0004	.0004	.0004	.0005	.0006	.0006	.0007	.0008	.0010	.0011
	E	.0001	.0001	.0002	.0003	.0004	.0004	.0005	.0006	.0006	.0007	.0007	.0009	.0009	.0011	.0012	.0013
	F	.0001	.0002	.0002	.0004	.0005	.0006	.0006	.0007	.0009	.0009	.0011	.0012	.0013	.0015	.0017	.0019
	G	.0002	.0002	.0004	.0006	.0007	.0007	.0009	.0010	.0012	.0013	.0015	.0016	.0017	.0020	.0023	.0025
	I	.0002	.0003	.0005	.0007	.0009	.0011	.0012	.0014	.0016	.0018	.0020	.0022	.0024	.0028	.0031	.0035
	J	.0003	.0004	.0007	.0010	.0012	.0014	.0017	.0019	.0022	.0024	.0027	.0030	.0032	.0037	.0043	.0047
	K	.0004	.0006	.0009	.0014	.0016	.0019	.0022	.0025	.0029	.0032	.0036	.0040	.0043	.0050	.0056	.0063
	N	.0005	.0007	.0011	.0019	.0022	.0025	.0029	.0034	.0038	.0043	.0048	.0053	.0057	.0066	.0075	.0083
	O	.0006	.0010	.0015	.0024	.0029	.0034	.0039	.0045	.0051	.0057	.0063	.0070	.0076	.0088	.0100	.0111
	P	.0008	.0014	.0020	.0033	.0038	.0045	.0052	.0060	.0068	.0076	.0084	.0094	.0100	.0117	.0133	.0148
	R	.0011	.0018	.0027	.0043	.0051	.0060	.0069	.0080	.0091	.0101	.0112	.0125	.0134	.0156	.0177	.0197
	S	.0015	.0024	.0036	.0058	.0067	.0080	.0091	.0106	.0120	.0135	.0149	.0166	.0178	.0207	.0236	.0263

FRAISES CARBURE – FACTEURS DE CORRECTION



1 Rainurage

Facteurs de correction de la vitesse de coupe v_c et de l'avance par dent f_z pour les opérations de rainurage à différentes profondeurs de coupe.

a_p / DC	25 %	50 %	100 %	150 %
	1.25	1.00	0.75	0.50
	1.25	1.00	0.75	0.50

2 Fraisage d'épaulements

Facteurs de correction de la vitesse de coupe v_c et de l'avance par dent f_z pour le surfaçage-dressage avec un engagement radial de < 50 %.

a_e / DC	5 %	10 %	15 %	20 %	25 %	30 %	40 %	≥ 50 %
	1.48	1.35	1.27	1.22	1.19	1.16	1.11	1.00
	2.29	1.67	1.40	1.25	1.15	1.09	1.02	1.00

Nous recommandons d'éviter le fraisage avec un engagement radial de 50 %.

3a Surfaçage (avec des fraises à bout sphérique)

Facteurs de correction de la vitesse de coupe v_c pour le surfaçage par copiage à différentes profondeurs de coupe

a_p / DC	5 %	10 %	15 %	20 %	25 %	30 %	40 %	50 %
	2.29	1.67	1.40	1.25	1.15	1.09	1.02	1.00

3b

Décalage f_e (distance de chevauchement) pour atteindre une rugosité de surface théorique R_{th}

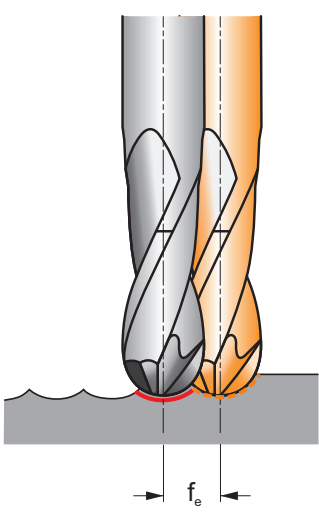
DC	μm	2	4	8	16	32	63	125	250
2		0.13	0.18	0.25	0.36	0.50	0.70	0.97	1.32
3		0.15	0.22	0.31	0.44	0.62	0.86	1.20	1.66
4		0.18	0.25	0.36	0.50	0.71	1.00	1.39	1.94
5		0.20	0.28	0.40	0.56	0.80	1.12	1.56	2.18
6		0.22	0.31	0.44	0.62	0.87	1.22	1.71	2.40
8		0.25	0.36	0.51	0.71	1.01	1.41	1.98	2.78
10		0.28	0.40	0.57	0.80	1.13	1.58	2.22	3.12
12		0.31	0.44	0.62	0.88	1.24	1.73	2.44	3.43
14		0.33	0.47	0.67	0.95	1.34	1.87	2.63	3.71
16		0.36	0.51	0.72	1.01	1.43	2.00	2.82	3.97
18		0.38	0.54	0.76	1.07	1.52	2.13	2.99	4.21
20		0.40	0.57	0.80	1.13	1.60	2.24	3.15	4.44
22		0.42	0.59	0.84	1.19	1.68	2.35	3.31	4.66
25		0.45	0.63	0.89	1.26	1.79	2.51	3.53	4.97
28	0.47	0.67	0.95	1.34	1.89	2.65	3.73	5.27	

Les dimensions de décalage sont affichées en mm uniquement.

FRAISES CARBURE – FACTEURS DE CORRECTION

3c

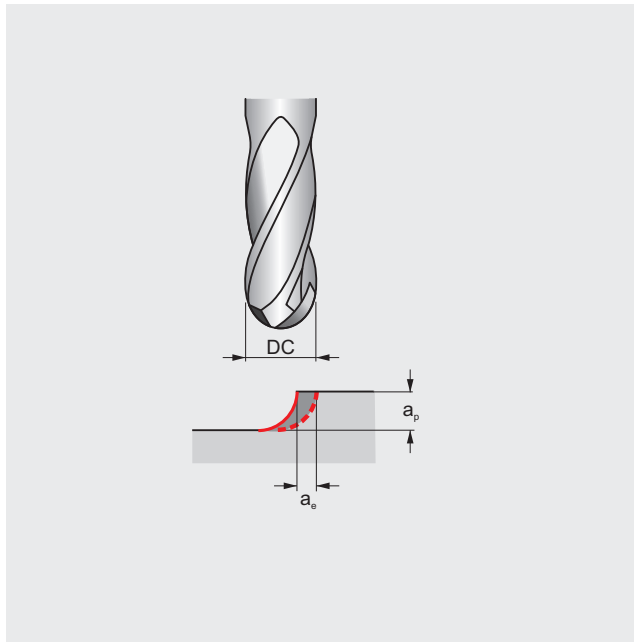

Comment trouver le facteur de correction de l'avance par dent (f_z ou IPT) pour le surfacage par copiage :

1. Trouver l'immersion radiale (a_e / DC) la plus proche de celle recherchée pour votre application (première ligne du tableau).
3. Trouver l'immersion axiale (a_p / DC) la plus proche de celle recherchée pour votre application (colonne gauche du tableau).
4. La cellule à l'intersection des immersions radiale et axiale indique le facteur de correction pour l'avance par dent.

Exemple de surfacage par copiage :

1. Utilisation d'une fraise à bout sphérique de 8 mm à une profondeur de coupe de 0.8 mm (a_p) pour atteindre une rugosité de surface théorique de 32 μm .
2. Le facteur de correction de la vitesse de coupe avec une immersion axiale de 10 % = 1.67 (tableau 3a).
3. La distance de chevauchement pour une R_{th} de 32 μm = 1.01 mm (tableau 3b).
4. Le facteur de correction pour une avance par dent avec une immersion axiale de 10 % et une immersion radiale de 1.01 / 8 = 12.6 % est ici de 2.33 (tableau 3c).

Facteurs de correction de l'avance par dent f_z pour le surfacage par copiage avec un décalage $< 50\% \times DC$ à différentes profondeurs de coupe.

APMX FFW	APMX EFW	5 %	10 %	15 %	20 %	25 %	30 %	35 %	40 %	50 %
5 %	$\times f_z$ 	5.26	3.82	3.21	2.87	2.65	2.50	2.40	2.34	2.29
10 %		3.82	2.78	2.33	2.08	1.92	1.82	1.75	1.70	1.67
15 %		3.21	2.33	1.96	1.75	1.62	1.53	1.47	1.43	1.40
20 %		2.87	2.08	1.75	1.56	1.44	1.36	1.31	1.28	1.25
25 %		2.65	1.92	1.62	1.44	1.33	1.26	1.21	1.18	1.15
30 %		2.50	1.82	1.53	1.36	1.26	1.19	1.14	1.11	1.09
35 %		2.40	1.75	1.47	1.31	1.21	1.14	1.10	1.07	1.05
40 %		2.34	1.70	1.43	1.28	1.18	1.11	1.07	1.04	1.02
45 %		2.31	1.68	1.41	1.26	1.16	1.10	1.05	1.03	1.01
50 %		2.29	1.67	1.40	1.25	1.15	1.09	1.05	1.02	1.00

Pour améliorer la qualité de surface, il est possible d'incliner l'outil ou la surface de 10° – 15°.



FRAISES CARBURE TYPE TONNEAU – TABLEAU DES AVANCES PAR DENT

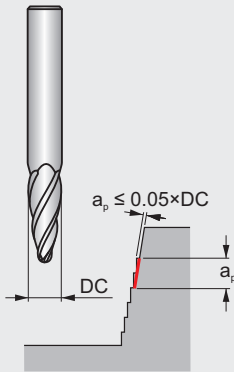

Avance par dent f_z en (mm). Ajuster ces valeurs de $\pm 25\%$ selon les conditions de travail.

Comment trouver l'avance par dent f_z grâce à ce tableau :

1. Rechercher le code Alpha sur la page produit (par ex. 121F, « F » étant le code Alpha).
2. Trouver le diamètre le plus proche de celui recherché pour votre application (première ligne du tableau).
3. Rechercher votre code Alpha dans la colonne gauche du tableau.
4. La cellule à l'intersection de la colonne Diamètre et de la ligne code Alpha indique l'avance par dent f_z .

FRAISES DE TYPE TONNEAU HM S791 UNIQUEMENT

		ø DC (mm)				
		6.00	8.00	10.00	12.00	16.00
Avances (mm)	E	0.030	0.039	0.053	0.067	0.096
	F	0.037	0.050	0.064	0.083	0.118
	I	0.062	0.084	0.111	0.141	0.203

FRAISES À FILETER – RECOMMANDATIONS GÉNÉRALES

Recommandations générales pour le fraisage par interpolation

1. Le fraisage par interpolation est le procédé par lequel on crée un filetage par interpolation circulaire d'une fraise avec une géométrie spécifique de filetage usinée autour de sa périphérie.
2. Pour pouvoir utiliser une fraise à fileter, il faut disposer d'une machine CNC capable de suivre un chemin circulaire.
3. La plupart des machines CNC modernes sont dotées de cycles d'usinage pour le fraisage de filets.
4. Consulter le manuel ou prendre contact avec le fabricant de la machine pour tout complément d'information.

Caractéristiques et avantages

1. Le fraisage par interpolation permet d'accroître la fiabilité et la durée de vie de l'outil.
2. Les fraises à fileter produisent des copeaux de petite taille et permettent ainsi de travailler sans problèmes.
3. Tolérance très précise.
4. Possibilité d'usiner un filet complet, jusqu'au fond du trou.
5. Capacité d'usinage dans un large éventail de matières.
6. La même fraise peut produire des filets de tailles différentes, à condition que le pas reste le même.
7. Un seul et même outil pour les filets à droite et à gauche.
8. Certaines fraises à fileter sont aussi capables d'usiner le chanfrein d'entrée (J200 et J205).

Choisir votre outil

Chaque fraise à fileter possède un code article basé sur le type, le diamètre *DC* et le pas *TP*.

Le code article est la désignation qu'il faut utiliser pour commander votre outil.

Consulter systématiquement le catalogue pour s'assurer que les dimensions du filet sont correctes.

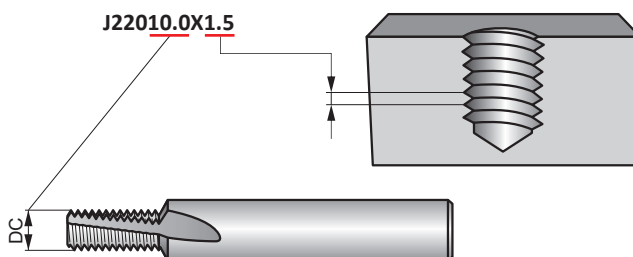

Cette fraise à fileter peut être utilisée pour les dimensions $\geq M12 \times 1.5$ (M14 \times 1.5, M18 \times 1.5, etc.)

Programmation avec la valeur Rprg

- Pour un réglage aisé de la tolérance de filet, utiliser toujours le programme avec correcteur de rayon.
- La valeur Rprg est la valeur de départ de chaque nouvelle fraise, elle est gravée sur la queue. Elle doit être saisie dans la mémoire du correcteur d'outils.
- La valeur Rprg est basée sur le zéro théorique du filet. Ainsi, l'utilisation de cette valeur Rprg dans la programmation garantit que le filet n'est jamais surcoté, mais normalement ajusté.
- Cela implique qu'il est possible d'obtenir le filetage à la taille voulue en ne modifiant que légèrement les coordonnées du programme.

Recommandations

- Utiliser toujours les données de coupe correctes.
- Utiliser la taille de foret recommandée pour le diamètre à tarauder, comme pour les tarauds conventionnels.
- Pour un réglage aisé de la tolérance de filet, toujours commencer avec la valeur Rprg gravée sur la queue de la fraise à fileter.
- Utiliser un calibre pour vérifier la tolérance sur le premier filet afin d'établir si le rayon doit être corrigé. Le rayon peut être corrigé 2 ou 3 fois avant que la fraise à fileter ne soit usée.
- En usinage à sec, il est recommandé d'aider à l'évacuation des copeaux avec de l'air comprimé.
- Lorsque la matière est plus difficile à fileter, il est recommandé de travailler en plusieurs passes.



FRAISES À FILETER – TABLEAU DES AVANCES PAR DENT

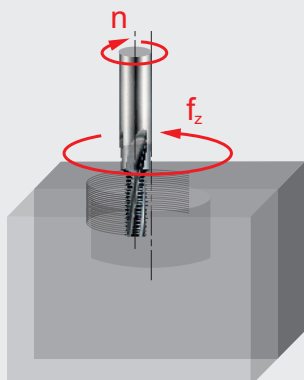

Comment trouver l'avance par dent f_z grâce à ce tableau (mm):

1. Rechercher le code Alpha sur la page produit (par ex. 181B, « B » étant le code Alpha).
2. Choisir la colonne correspondant au diamètre de votre fraise dans la première ligne du tableau avec le pas du filet P ou TPI (lignes flanquées d'icônes sur la gauche).
3. Rechercher votre code Alpha dans la colonne gauche du tableau.
4. La cellule à l'intersection de la colonne Diamètre + pas et de la ligne code Alpha indique l'avance par dent f_z .

Correction de l'avance par dent en cas de plusieurs passes :

1. Si le filet est usiné en **2 passes**, les valeurs d'avance du tableau doivent être augmentées de **30 à 40 %**.
2. Si le filet est usiné en **3 passes**, les valeurs d'avance du tableau doivent être augmentées de **55 à 65 %**.
3. Si le filet est usiné en **4 passes**, les valeurs d'avance du tableau doivent être augmentées de **80 à 90 %**.

(Exemple : J2003.2X.7 usinant du WMG M4.1 avec une avance A en 4 passes : $f_z = 0.017 \times 1.80 = 0.031$ mm/dent).

Les valeurs indiquées sont les valeurs de départ recommandées pour l'usinage de la profondeur totale du filet en une seule passe.

		ø DC (mm)																											
		3.20	4.10	4.50	4.80	5.50	6.00	-	6.50	7.50	7.90	8.00	8.20	9.50	9.90	10.00	-	11.60	12.00	-	13.60	14.00	-	16.00	-	-	19.00	20.00	25.00
Avances (mm)		0.70	0.80	1.00	1.00	-	1.25	-	1.25	1.50	-	-	1.50	1.75	1.75	2.00	-	2.00	2.00	-	2.00	-	-	-	-	-	-	-	-
	A	0.017	0.022	0.023	0.024	-	0.024	-	0.029	0.036	-	-	0.040	0.044	0.047	0.053	-	0.056	0.068	-	0.071	-	-	-	-	-	-	-	-
	B	0.022	0.029	0.031	0.032	-	0.032	-	0.038	0.048	-	-	0.053	0.059	0.063	0.070	-	0.075	0.090	-	0.095	-	-	-	-	-	-	-	-
	C	0.028	0.036	0.039	0.040	-	0.040	-	0.048	0.060	-	-	0.066	0.074	0.079	0.088	-	0.094	0.113	-	0.119	-	-	-	-	-	-	-	-
		-	-	-	0.50	-	0.75	1.00	-	-	-	1.00	-	-	-	1.00	1.50	-	1.00	1.50	-	1.00	1.50	1.50	2.00	2.50	3.00	2.00	-
	D	-	-	-	0.044	-	0.041	0.036	-	-	-	0.057	-	-	-	0.075	0.067	-	0.079	0.071	-	0.083	0.071	0.092	0.081	0.073	0.067	0.096	-
	E	-	-	-	0.058	-	0.055	0.048	-	-	-	0.076	-	-	-	0.100	0.089	-	0.105	0.094	-	0.110	0.095	0.122	0.108	0.097	0.089	0.128	-
	F	-	-	-	0.073	-	0.069	0.060	-	-	-	0.095	-	-	-	0.125	0.111	-	0.131	0.118	-	0.138	0.119	0.153	0.135	0.121	0.111	0.160	-
		-	-	-	20	18	-	-	-	16	14	-	-	-	13	12	-	11	-	-	10	-	-	-	-	-	-	-	-
	G	-	-	-	0.019	0.023	-	-	-	0.030	0.034	-	-	-	0.053	0.051	-	0.055	-	-	0.066	-	-	-	-	-	-	-	-
	H	-	-	-	0.025	0.030	-	-	-	0.040	0.045	-	-	-	0.071	0.068	-	0.073	-	-	0.088	-	-	-	-	-	-	-	-
	I	-	-	-	0.031	0.038	-	-	-	0.050	0.056	-	-	-	0.089	0.085	-	0.091	-	-	0.110	-	-	-	-	-	-	-	-
		-	-	-	28	24	-	-	-	20	-	-	-	18	-	-	-	-	-	16	-	-	-	-	-	-	-	-	-
	J	-	-	-	0.023	0.026	-	-	-	0.041	-	-	-	0.062	-	-	-	-	-	0.083	-	-	-	-	-	-	-	-	-
	K	-	-	-	0.030	0.035	-	-	-	0.054	-	-	-	0.083	-	-	-	-	-	0.110	-	-	-	-	-	-	-	-	-
L	-	-	-	0.038	0.044	-	-	-	0.068	-	-	-	0.104	-	-	-	-	-	0.138	-	-	-	-	-	-	-	-	-	
	-	-	-	-	28	-	-	-	-	-	-	-	19	-	-	-	-	-	19	-	14	-	-	-	-	14	11		
M	-	-	-	-	0.029	-	-	-	-	-	-	-	0.064	-	-	-	-	-	0.080	-	0.083	-	-	-	-	0.116	0.131		
N	-	-	-	-	0.038	-	-	-	-	-	-	-	0.085	-	-	-	-	-	0.106	-	0.111	-	-	-	-	0.155	0.175		
O	-	-	-	-	0.048	-	-	-	-	-	-	-	0.106	-	-	-	-	-	0.133	-	0.139	-	-	-	-	0.194	0.219		
	-	-	-	-	-	-	-	-	27	-	-	-	18	-	-	-	-	-	14	11.5	-	-	-	-	-	-	-		
Q	-	-	-	-	-	-	-	-	0.039	-	-	-	0.044	-	-	-	-	-	0.079	0.115	-	-	-	-	-	-	-		
R	-	-	-	-	-	-	-	-	0.052	-	-	-	0.059	-	-	-	-	-	0.105	0.153	-	-	-	-	-	-	-		
S	-	-	-	-	-	-	-	-	0.065	-	-	-	0.074	-	-	-	-	-	0.131	0.191	-	-	-	-	-	-	-		

FRAISES À FILETER – TABLEAU DU NOMBRE DE PASSES

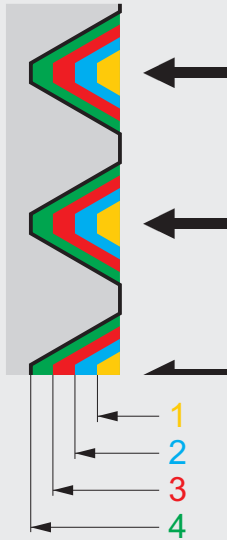

Comment trouver les incréments de profondeur par passe dans les tableaux suivants :

1. Sélectionner le tableau correspondant à votre profil de filet (par ex.: «M12» pour un filet métrique).
2. Trouver la colonne correspondant à votre pas du filet (première ligne du tableau).
3. Rechercher dans cette colonne le nombre de passes recommandé et l'incrément de profondeur radiale de coupe pour chaque passe. (Exemple : pour un pas de 1.75, le nombre de passes recommandé est de 5; la profondeur de la 1ère passe de 0.277 mm, l'incrément de profondeur en 2ème passe de 0.228 mm, etc.).
4. Il est recommandé d'augmenter le nombre de passes pour les matériaux plus difficiles à usiner.
5. Pour une super-finition, il est préférable de répéter la dernière passe.

Recommandations: nombre de passes et profondeur radiale de coupe par passe pour un filet métrique intérieur (60°).

		Profondeur de coupe par passe (mm)										
		0.50	0.70	0.75	0.80	1.00	1.25	1.50	1.75	2.00	2.50	3.00
Nb de passes	1	0.158	0.221	0.168	0.224	0.224	0.228	0.237	0.277	0.283	0.323	0.387
	2	0.131	0.183	0.138	0.185	0.185	0.188	0.196	0.228	0.234	0.267	0.320
	3	–	–	0.127	0.135	0.168	0.173	0.179	0.209	0.214	0.244	0.293
	4	–	–	–	–	–	0.133	0.138	0.161	0.164	0.187	0.225
	5	–	–	–	–	–	–	0.116	0.135	0.138	0.158	0.189
	6	–	–	–	–	–	–	–	–	0.122	0.139	0.167
	7	–	–	–	–	–	–	–	–	–	0.125	0.151
Prof. totale		0.289	0.404	0.433	0.544	0.577	0.722	0.866	1.010	1.155	1.443	1.732

Recommandations: nombre de passes et profondeur radiale de coupe par passe pour un filet unifié intérieur (60°).

		Profondeur de coupe par passe (mm)									
		28	24	20	18	16	14	13	12	11	10
Nb de passes	1	0.203	0.237	0.232	0.258	0.251	0.287	0.309	0.299	0.327	0.328
	2	0.167	0.195	0.191	0.213	0.207	0.237	0.255	0.247	0.270	0.271
	3	0.154	0.179	0.175	0.195	0.190	0.217	0.234	0.226	0.247	0.248
	4	–	–	0.135	0.149	0.146	0.166	0.179	0.174	0.189	0.190
	5	–	–	–	–	0.123	0.140	0.151	0.146	0.160	0.160
	6	–	–	–	–	–	–	–	0.130	0.140	0.141
	7	–	–	–	–	–	–	–	–	–	0.128
Prof. totale		0.524	0.611	0.733	0.815	0.917	1.047	1.128	1.222	1.333	1.466



FRAISES À FILETER – TABLEAU DU NOMBRE DE PASSES

Recommandations: nombre de passes et profondeur radiale de coupe par passe pour un filet G (BSP) intérieur (55°).

 1"		Profondeur de coupe par passe (mm)			
		28	19	14	11
Nb de passes	1	0.225	0.271	0.318	0.362
	2	0.186	0.224	0.263	0.299
	3	0.170	0.205	0.241	0.274
	4	–	0.156	0.185	0.210
	5	–	–	0.155	0.177
	6	–	–	–	0.157
	7	–	–	–	–
Prof. totale		0.581	0.856	1.162	1.479

Recommandations: nombre de passes et profondeur radiale de coupe par passe pour un filet NPT intérieur (60°).

 1"		Profondeur de coupe par passe (mm)			
		27	18	14	11.5
Nb de passes	1	0.283	0.348	0.390	0.423
	2	0.233	0.287	0.322	0.349
	3	0.214	0.263	0.295	0.320
	4	–	0.202	0.226	0.246
	5	–	–	0.190	0.207
	6	–	–	–	0.183
	7	–	–	–	–
Prof. totale		0.730	1.100	1.423	1.728

FRAISES LIMES ROTATIVES – CONSEILS D'UTILISATION

Recommandations générales pour les fraises en carbure

Les fraises en carbure sont couramment employées pour la préparation et la finition, dans les matières les plus variées. Elles sont généralement utilisées à la main, montées dans une meuleuse pneumatique.

Caractéristiques et avantages

1. La queue en acier trempé et durci améliore la rigidité et réduit le risque de flexion ou de vibrations.
2. La grande précision d'usinage de la queue améliore la qualité de serrage et réduit la probabilité de patinage.
3. Les éléments spéciaux de brasage préviennent le bris à haute température et apportent par ailleurs une rigidité accrue pour supporter la pression et les chocs.
4. La géométrie universelle à denture croisée convient aux matières et aux applications les plus variées.
5. Des géométries spécialisées sont également disponibles spécifiquement pour l'acier (ST), l'inox (VA), l'aluminium (AL) et la fibre de verre (GRP).
6. Disponible avec revêtement au TiAlN pour accroître la longévité dans les matières abrasives.
7. Les fraises à bout sphérique sont usinées avec une goujure à géométrie de type "Skip".
8. Géométrie active près du centre de la fraise, qui améliore l'action de coupe et réduit le risque d'agglomération des copeaux.

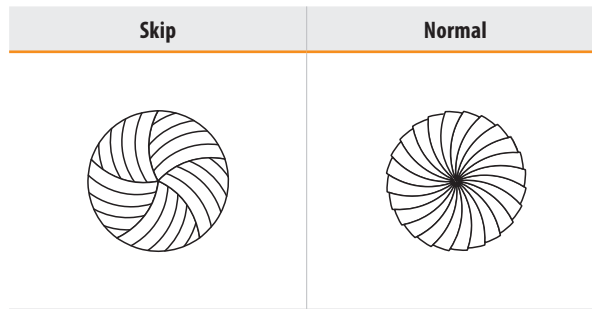

Sécurité primordiale

1. Les outils qui tournent à haute vitesse sont dangereux et peuvent présenter des risques s'ils sont mal utilisés.
2. Toujours déconnecter la meuleuse de l'alimentation en air comprimé avant d'entreprendre un changement de fraise.
3. Contrôler l'état de la meuleuse et si possible, utiliser un modèle à faibles vibrations.
4. Toujours utiliser un équipement de protection adapté et veiller à ce que toute personne travaillant à proximité soit également protégée.



L'équipement de protection individuelle doit être porté en toutes circonstances!

FRAISES LIMES ROTATIVES – CONSEILS D'UTILISATION

Recommandations

- Toujours utiliser une meuleuse de vitesse nominale adaptée.
- L'entretien périodique des meuleuses est important, contrôler qu'elles sont huilées et que les roulements ne sont pas usés.
- Toujours nettoyer la pince et l'écrou de serrage, ainsi que le cône intérieur, à chaque changement de fraise.
- Essayer d'éviter les chocs mécaniques et tout impact important sur les fraises.
- Essayer d'éviter les chocs thermiques, en ne laissant pas la fraise surchauffer.
- Ne pas plonger la fraise trop profondément dans la pièce, ni la coincer dans les angles ou les gorges.

Résolution des problèmes lors de l'utilisation des fraises

Problème	Cause
Écaillage de la denture de la fraise	Vitesse de travail trop lente, cause possible de rebond
	Excentricité (broche, pince ou roulements usés)
	Plongée et bourrage de la fraise dans la pièce
Colmatage de la denture de la fraise	Goujure trop longue ou longueur totale trop grande
	Choix incorrect de géométrie pour la matière à travailler
Usure prématurée	Vitesse de travail trop rapide pour la taille de fraise et la matière à travailler
	Excentricité (broche, pince ou roulements usés)
La tête se détache de la queue	Vitesse de travail trop rapide entraînant une surchauffe
	Période prolongée de travail entraînant une surchauffe

FRAISES LIMES ROTATIVES – VITESSES DE ROTATION RECOMMANDÉES

		AL DC						
ISO		(tour/min)						
		DC (mm)						
		3	6	8	10	12	16	20
P	min.	64 000	32 000	24 000	20 000	16 000	12 000	10 000
	max.	83 000	42 000	32 000	25 000	21 000	16 000	13 000
M	min.	45 000	23 000	17 000	14 000	12 000	9 000	7 000
	max.	64 000	32 000	24 000	20 000	16 000	12 000	10 000
K	min.	58 000	29 000	22 000	19 000	15 000	11 000	9 000
	max.	77 000	39 000	29 000	23 000	20 000	15 000	12 000
N	min.	64 000	32 000	24 000	20 000	16 000	12 000	10 000
	max.	96 000	48 000	36 000	29 000	24 000	18 000	15 000
S	min.	45 000	23 000	17 000	14 000	12 000	9 000	7 000
	max.	58 000	29 000	22 000	18 000	15 000	11 000	9 000
H	min.	51 000	26 000	20 000	16 000	13 000	10 000	8 000
	max.	71 000	36 000	27 000	22 000	18 000	14 000	11 000

		ST BR				
ISO		(tour/min)				
		DC (mm)				
		3	6	8	10	12
P	min.	100 000	65 000	60 000	55 000	35 000
	max.	60 000	45 000	35 000	30 000	20 000

		VA BR				
ISO		(tour/min)				
		DC (mm)				
		3	6	8	10	12
M	min.	100 000	65 000	60 000	55 000	35 000
	max.	60 000	30 000	25 000	20 000	15 000

		GRP		
ISO		(tour/min)		
		DC (mm)		
		3	6	8
N4	min.	25 000	20 000	18 000
	max.	30 000	25 000	22 000

		AS	
ISO		(tour/min)	
		DC (mm)	
		3	
S	min.	60 000	
	max.	80 000	



GROUPES DE MATÉRIAUX À USINER (WMG)

Groupe ISO	Groupes de matériaux à usiner (WMG)		Dureté (HB ou HRC)	Résistance à la traction max. (MPa)		
P	P1	P1.1	Manganèse	< 240 HB	≤ 830	
		P1.2	Acier de décolletage (aciers au carbone, usinabilité accrue)	Manganèse et phosphore	< 180 HB	≤ 620
		P1.3		Manganèse/phosphore et plomb	< 180 HB	≤ 620
	P2	P2.1	Acier simple au carbone (aciers principalement composés de fer et de carbone)	Teneur en carbone <0,25 %c	< 180 HB	≤ 620
		P2.2		Teneur en carbone <0,55 %c	< 240 HB	≤ 830
		P2.3		Teneur en carbone <0,55 %c	< 300 HB	≤ 1030
	P3	P3.1	Acier allié (aciers au carbone avec une teneur en alliage ≤ 10 %)	Recuit	< 180 HB	≤ 620
		P3.2		Durci et trempé	180 – 260 HB	> 620 ≤ 900
		P3.3			260 – 360 HB	> 900 ≤ 1240
	P4	P4.1	Acier à outil (acier allié spécial pour outils, moules et matrices)	Recuit	< 26 HRC	≤ 900
P4.2		Durci et trempé		26 – 39 HRC	> 900 ≤ 1240	
P4.3				39 – 45 HRC	> 1240 ≤ 1450	
M	M1	M1.1	Acier inoxydable ferritique (alliages non durcissables au chrome droit)	< 160 HB	≤ 520	
		M1.2		160 – 220 HB	> 520 ≤ 700	
	M2	M2.1	Acier inoxydable martensitique (alliages durcissables au chrome droit)	Recuit	< 200 HB	≤ 670
		M2.2		Revenu et trempé	200 – 280 HB	> 670 ≤ 950
		M2.3		Durci par précipitation	280 – 380 HB	> 950 ≤ 1300
	M3	M3.1	Acier inoxydable austénitique (alliages chrome-nickel et chrome-nickel-manganèse)	< 200 HB	≤ 750	
		M3.2		200 – 260 HB	> 750 ≤ 870	
		M3.3		260 – 300 HB	> 870 ≤ 1040	
	M4	M4.1	Acier inoxydable super-austénitique et austéno-ferritique (duplex)	< 300 HB	≤ 990	
		M4.2	Acier inoxydable austénitique à durcissement par précipitation	300 – 380 HB	≤ 1320	
K	K1	K1.1	Fonte grise (ASTM A48) ou fonte grise pour l'automobile (ASTM A159) (pièces moulées en fer-carbone avec micro-structure graphite lamellaire)	Ferritique ou ferritique-perlitique	< 180 HB	≤ 190
		K1.2		Ferritique-perlitique ou perlitique	180 – 240 HB	> 190 ≤ 310
		K1.3		Perlitique	240 – 280 HB	> 310 ≤ 390
	K2	K2.1	Fonte malléable (ASTM A602) (pièces moulées en fer-carbone avec micro-structure sans graphite)	Ferritique	< 160 HB	≤ 400
		K2.2		Ferritique ou perlitique	160 – 200 HB	> 400 ≤ 550
		K2.3		Perlitique	200 – 240 HB	> 550 ≤ 660
	K3	K3.1	Fonte malléable (ASTM A536) (pièces moulées en fer-carbone avec micro-structure en graphite nodulaire)	Ferritique	< 180 HB	≤ 560
		K3.2		Ferritique ou perlitique	180 – 220 HB	> 560 ≤ 680
		K3.3		Perlitique	220 – 260 HB	> 680 ≤ 800
	K4	K4.1	Fonte grise austénitique (ASTM A436) (pièces moulées en alliage fer-carbone avec micro-structure graphite lamellaire austénitique)	< 180 HB	≤ 190	
		K4.2	Fonte malléable austénitique (ASTM A439 ou ASTM A571) (alliage fer-carbone avec micro-structure graphite nodulaire austénitique)	< 240 HB	≤ 740	
		K4.3	Fonte malléable à trempe étagée (ASTM A897) (alliage fer-carbone avec micro-structure ausferritique)	< 280 HB	> 840 ≤ 980	
		K4.4		280 – 320 HB	> 980 ≤ 1130	
		K4.5		320 – 360 HB	> 1130 ≤ 1280	
		K5	K5.1	Fonte à graphite vermiculaire compactée (ASTM A842) (pièces moulées en fer-carbone avec structure graphite vermiculaire)	Ferritique	< 180 HB
K5.2	Ferritique-perlitique		180 – 220 HB		> 400 ≤ 450	
K5.3	Perlitique		220 – 260 HB		> 450 ≤ 500	
N	N1	N1.1	Alliages d'aluminium corroyé	< 60 HB	≤ 240	
		N1.2		Semi-trempé	60 – 100 HB	> 240 ≤ 400
		N1.3		Trempé	100 – 150 HB	> 400 ≤ 590
	N2	N2.1	Alliages d'aluminium moulé	< 75 HB	≤ 240	
		N2.2		75 – 90 HB	> 240 ≤ 270	
		N2.3		90 – 140 HB	> 270 ≤ 440	
	N3	N3.1	Alliages de cuivre de décolletage avec d'excellentes propriétés d'usinage	–	–	
		N3.2	Alliages de cuivre à copeaux courts avec des propriétés d'usinage bonnes à moyennes	–	–	
		N3.3	Alliages de cuivre à longs copeaux et cuivre électrolytique avec des propriétés d'usinage médiocres à moyennes	–	–	
	N4	N4.1	Polymères et thermoplastiques	–	–	
		N4.2	Polymères thermodurcissables	–	–	
		N4.3	Polymères renforcés ou composites	–	–	
	N5	N5.1	Graphite	–	–	
	S	S1	S1.1	Titane ou alliages de titane	< 200 HB	≤ 660
			S1.2		200 – 280 HB	> 660 ≤ 950
S1.3			280 – 360 HB		> 950 ≤ 1200	
S2		S2.1	Alliages à base de fer haute température	< 200 HB	≤ 690	
		S2.2		200 – 280 HB	> 690 ≤ 970	
S3		S3.1	Alliages à base de nickel haute température	< 280 HB	≤ 940	
		S3.2		280 – 360 HB	> 940 ≤ 1200	
S4		S4.1	Alliages à base de cuivre haute température	< 240 HB	≤ 800	
	S4.2	240 – 320 HB		> 800 ≤ 1070		
H	H1	H1.1	Fonte en coquille	< 440 HB	–	
	H2	H2.1	Fonte trempée	< 55 HRC	–	
		H2.2		> 55 HRC	–	
	H3	H3.1	Acier trempé < 55 HRC	< 51 HRC	–	
		H3.2		51 – 55 HRC	–	
	H4	H4.1	Acier trempé > 55 HRC	55 – 59 HRC	–	
		H4.2		> 59 HRC	–	



TABLE DE CONVERSION DE DURETÉ

Résistance (MPa)	Dureté			
	BRINELL	VICKERS	ROCKWELL	ROCKWELL
R_m	HB	HV	HRB	HRC
285	86	90	1190	–
320	95	100	56.2	–
350	105	110	62.3	–
385	114	120	66.7	–
415	124	130	71.2	–
450	133	140	75.0	–
480	143	150	78.7	–
510	152	160	81.7	–
545	162	170	85.8	–
575	171	180	87.1	–
610	181	190	89.5	–
640	190	200	91.5	–
675	199	210	93.5	–
705	209	220	95	–
740	219	230	96.7	–
770	228	240	98.1	–
800	238	250	99.5	–
820	242	255	–	23.1
850	252	265	–	24.8
880	261	275	–	26.4
900	266	280	–	27.1
930	276	290	–	28.5
950	280	295	–	29.2
995	295	310	–	31.0
1030	304	320	–	32.2
1060	314	330	–	33.3
1095	323	340	–	34.4
1125	333	350	–	35.5
1155	342	360	–	36.6

Résistance (MPa)	Dureté			
	BRINELL	VICKERS	ROCKWELL	ROCKWELL
R_m	HB	HV	HRB	HRC
1190	352	370	–	37.7
1220	361	380	–	38.8
1255	371	390	–	39.8
1290	380	400	–	40.8
1320	390	410	–	41.8
1350	399	420	–	42.7
1385	409	430	–	43.6
1420	418	440	–	44.5
1455	428	450	–	45.3
1485	437	460	–	46.1
1520	447	470	–	46.9
1555	456	480	–	47.7
1595	466	490	–	48.4
1630	475	500	–	49.1
1665	485	510	–	49.8
1700	494	520	–	50.5
1740	504	530	–	51.1
1775	513	540	–	51.7
1810	523	550	–	52.3
1845	532	560	–	53.0
1880	542	570	–	53.6
1920	551	580	–	54.1
1955	561	590	–	54.7
1995	570	600	–	55.2
2030	580	610	–	55.7
2070	589	620	–	56.3
2105	599	630	–	56.8
2145	608	640	–	57.3
2180	618	650	–	57.8

SIMPLY RELIABLE

Un copeau peut vous raconter une histoire de part sa forme et son fractionnement. En tant que professionnel, vous pouvez juger de la qualité d'un usinage rien qu'en le regardant. Le copeau envoie un message clair et évident, c'est pourquoi nous l'avons choisi comme symbole, **efficace tout simplement.**

DORMER PRAMET

www.dormerpramet.com



**CONTACTEZ VOTRE
SERVICE CLIENTS LOCAL
TOUJOURS À JOUR!**



DP-CAT-SOLIDMILL-2024-FR

FOLLOW US...



ONLINE



SEGMENTS



LIBRARY APP.



CALCULATOR APP.